

Top 100
Global
Innovator
for 10 years

XGB Series

Programmable Logic Controller



LS ELECTRIC

Programmable Logic Controller

XGB Series

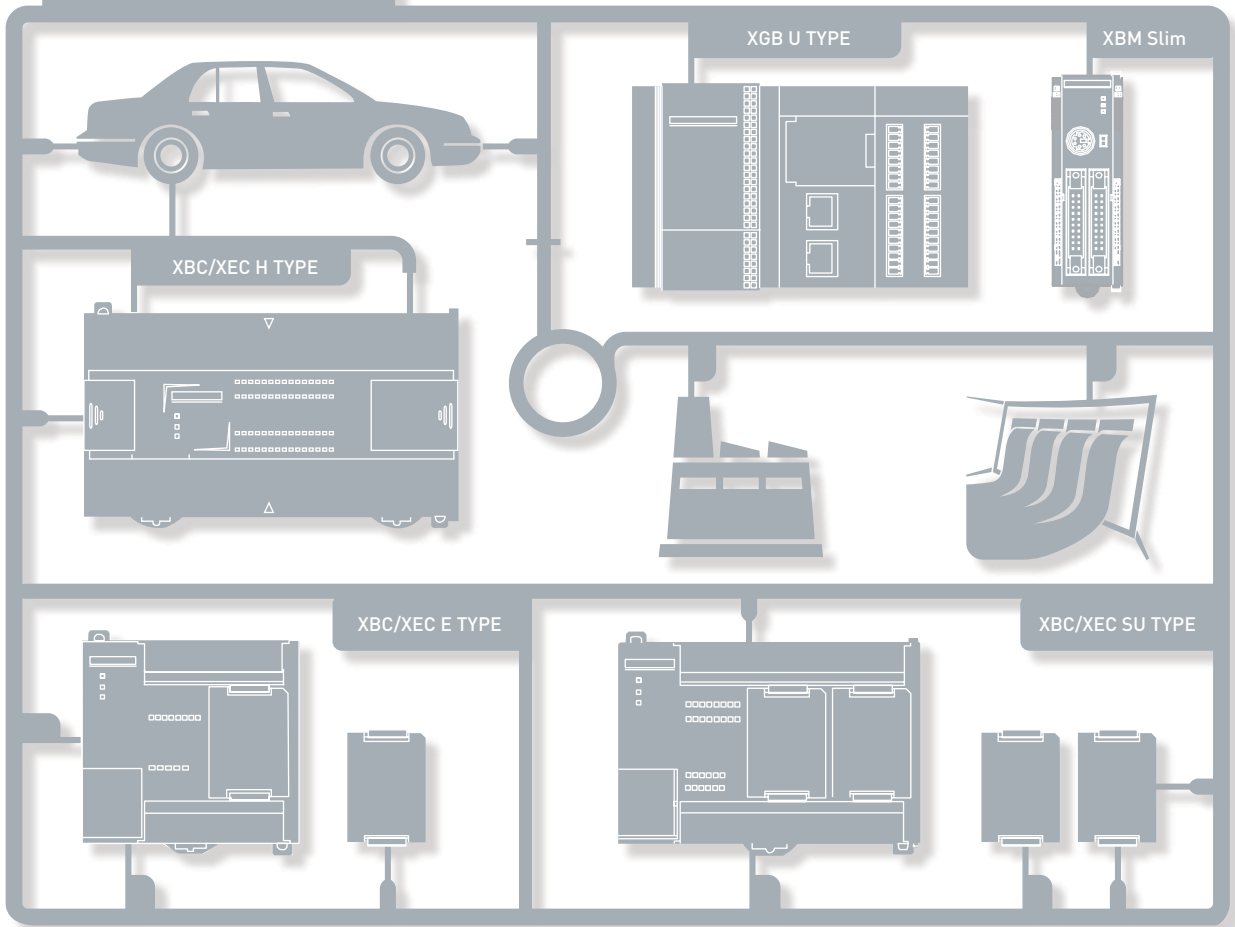

EASINESS

COMPACTNESS

FUNCTIONALITY

CONVENIENCE

HIGH PERFORMANCE

Programmable Logic Controller
XGB Series



FEATURES
4 ~ 15

FEATURES

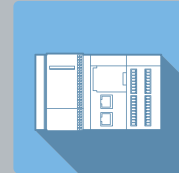

XBC/XEC U
16 ~ 23

XGB U

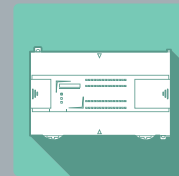

XBC/XEC H
24 ~ 29

XBC/XEC H

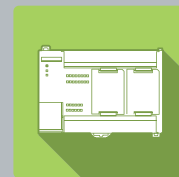

XBC/XEC SU
30 ~ 33

XBC/XEC SU

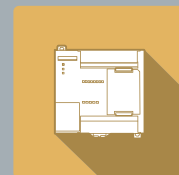

XBC/XEC E
40 ~ 47

XBC/XEC E

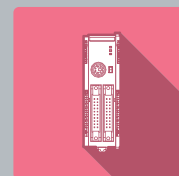

XBM Slim
48 ~ 61

XBM Slim



APPLICATION
62 ~ 120

APPLICATION

All-In-One PLC

With Next Generation Technology



XGB

XGB is a micro PLC that offers maximum performance at minimum cost.

With its high functionality, XGB supports from simple control system to complex task.

Strengthening its communication functions, XGB offers user-oriented integrated control.

Based on its strengths, XGB can be used in many application fields.



Series

It's Slim It's Powerful



It's Slim

Item Size (W×H×D)	XBC/XEC U Type (Standard)	XBC/XEC H Type	XBC/XEC SU Type	XBC/XEC E Type	XBM Slim Type
Size (W×H×D)	150×64×90	114×64×90	135×64×90	100×64×90	30×60×90

Expansion	Special Module	Communication Module
Size (W×H×D)	20×63×90	27×63×90

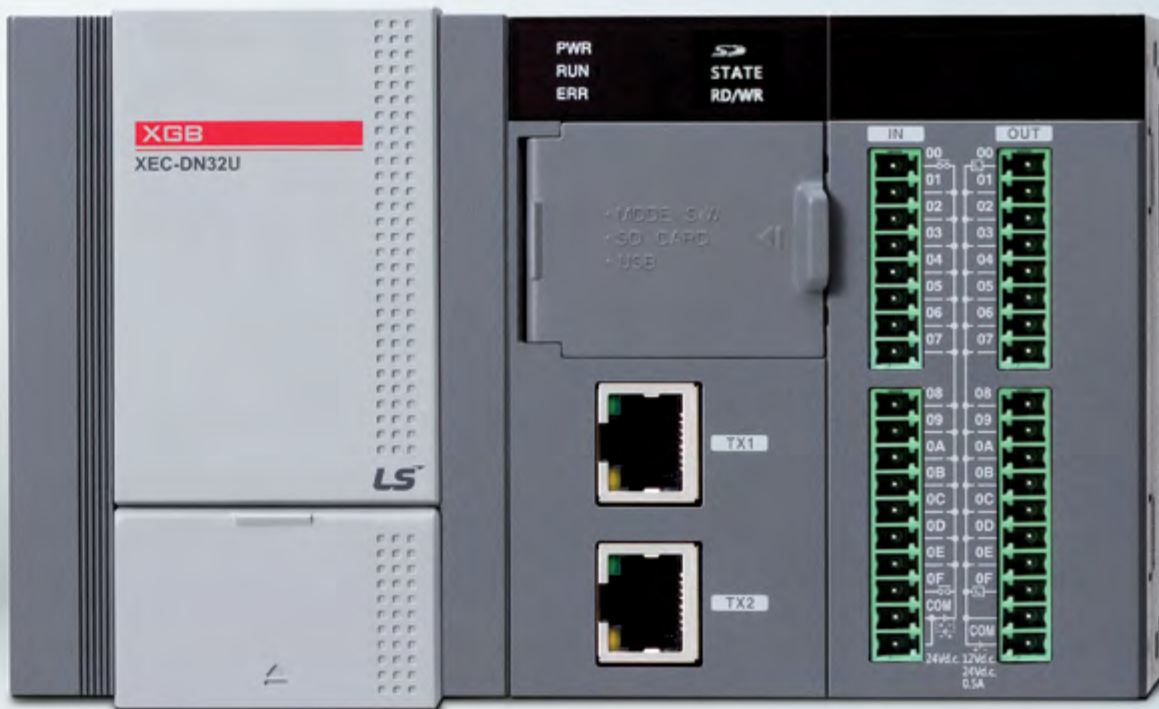

※ The actual size of the product

It's Powerful

Ethernet
1 Ch.
(Dual Port)

RS-232C
1 Ch.

RS-485
1 Ch.

PID

Web
Server

Data Log

USB

Pulse catch

High speed
counter
8 Ch.

Analog
input/
output 8 Ch.

Positioning
4 axes

External
interrupt

※ XBC/XEC U Type

What you have dreamed of, we make it happen.

XGB U sets new standards in **Ultimate performance** with its many innovations

IoT (Internet of Things) realizes smart factories

XGB-U is a **user-oriented** controller





Various Expansion

- Compatible with XGB expansion modules
- Max. 2 High speed backplane expansion modules
- Max. 10 expansion modules
- Max. 352 I/O points
- Expansion I/O module
 - DC24 input, Transistor output, Relay output
- Special module
 - Analog input, Analog output, RTD, Thermocouple, High-speed counter, Positioning (Line drive 2 axes, EtherCAT network 8 axes)
- Communication modules
 - RS-232C, RS-422/485, Ethernet, CANopen (Master/Slave), Profibus-DP (Master/Slave), DeviceNet (Slave), EtherNet/IP, RAPIEnet

Expansion(XBC/XEC U Type)

- Max. 10 expansion modules
 - Max. 2 High speed backplane modules
 - Max. 2 Communication modules

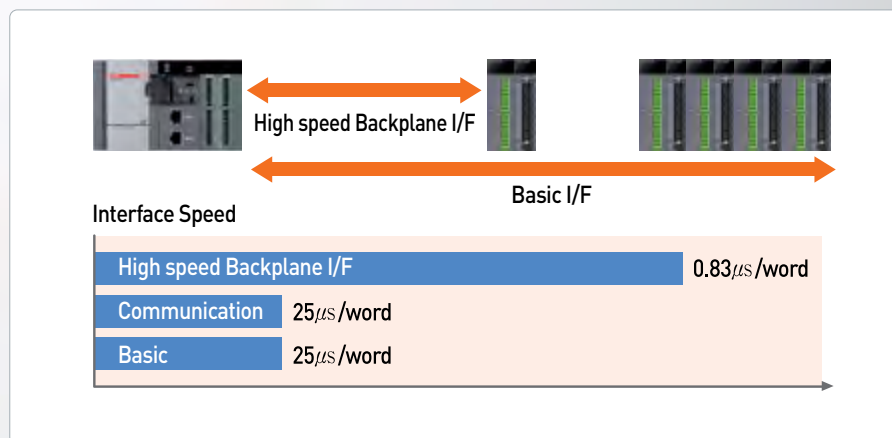

Data Log

- Easy parameter set up for [General save], [Trigger save], [Event save] without instruction
- 16GB of operation data storable
- Additional function
 - SD memory format, FTP link, Diagnosis, Sending email attached with a data log file
 - PLC program upload/download
 - O/S update

Dual Port Ethernet(XBC/XEC U type)

- 2 ports unmanaged Ethernet switch support
- Cost saving through simple wiring
- FTP server support (Data logging)

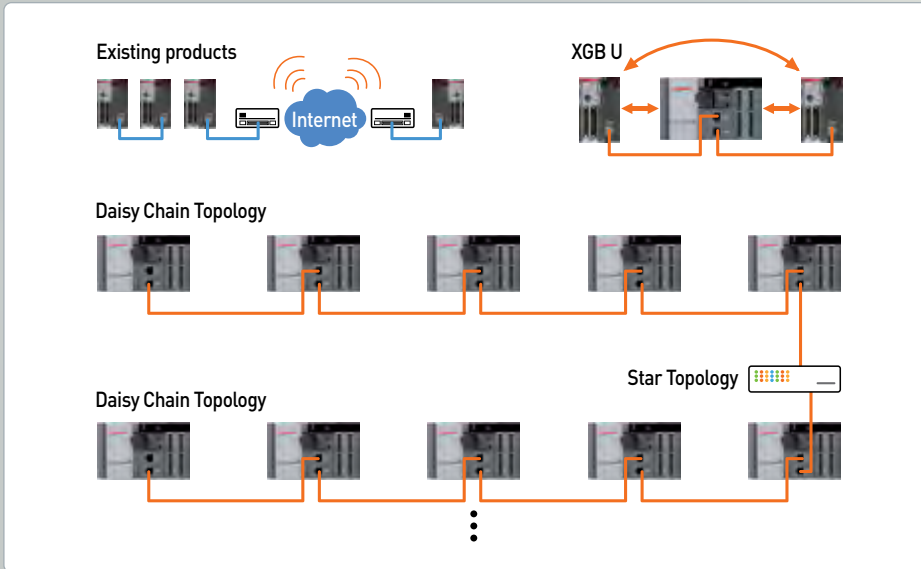

Web Server

- Monitoring of PLC information and data through web browser (PLC basic info., module info., diagnosis, device monitoring, flag monitoring, data log file download, O/S update, ladder program update, etc.)
- Time synchronization by setting basic parameters (SNTP: Simple Network Time Protocol)
- Email service through commercial email (SMTP: Simple Mail Transfer Protocol)

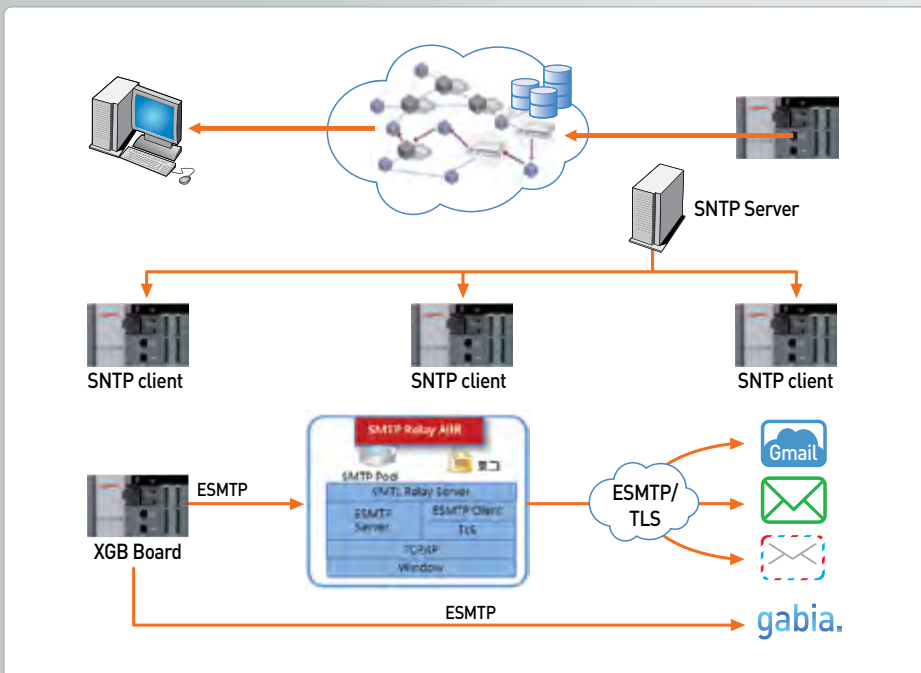

Compactness Function
High Performance Easiness

Ultimate Performance Universal IoT User Oriented



U will experience the utmost efficiency for your applications with U's outstanding features

Powerful built-in function

Built-in high speed counter

Phase	XBC/XEC				XBM
	U	H	SU	E	
1 Phase	100kHz(8Ch)	100kHz(4Ch) 20kHz(4Ch)	100kHz(2Ch) 20kHz(6Ch)	4kHz	20kHz
	8Ch	8Ch	8Ch	4Ch	4Ch
2 Phase	50kHz(4Ch)	50kHz(4Ch) 10kHz(4Ch)	50kHz(1Ch) 8kHz(3Ch)	2kHz	2 multiplication: 10kHz 4 multiplication: 8kHz
	4Ch	4Ch	4Ch	2Ch	2Ch



Built-in PID function

- It supports built-in PID control function up to 16 loops.
 - It provides parameter setting using XG5000, convenient loop state monitoring through trend monitor.
 - It can simply get a coefficient value by improved auto-tuning algorithm
 - Control accuracy improvement by using various additional functions such as PWM output, ΔMV , ΔPV , SV Ramp, etc.
 - It provides various control modes such as forward/reverse mixed operation, 2-stage SV PID control, cascade control, etc.
 - Various alarm functions such as MV high/low limit, PV high/low limit, PV variation

Built-in analog I/O function (Available for XBC/XEC-DN32UA type only)

- Built-in analog input 4 channels (voltage/current, 14bit)
- Built-in analog output 4 channels (voltage/current 14bit)

Built-in position control function (Available for XBC/XEC-DN32UP type only)

- Line drive output positioning function with up to 2Mpps 4-axis
- Parameter set up by XG-PM providing operation data edition, divers monitoring and diagnosis functions.

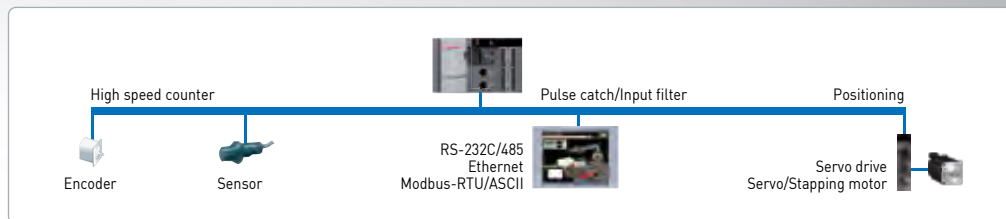

Features

With its high-speed processing and system capability, XGB offers the utmost efficiency for your applications.



XBC/XEC U

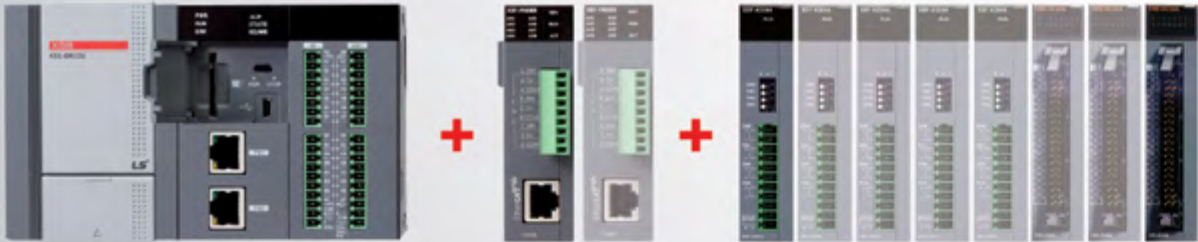

Standard type

Max. 10 stages (High speed interface module : Max. 2 stages)

XBC/XEC H



Max. 10 stage (Including communication 2 stages)

XBC/XEC SU

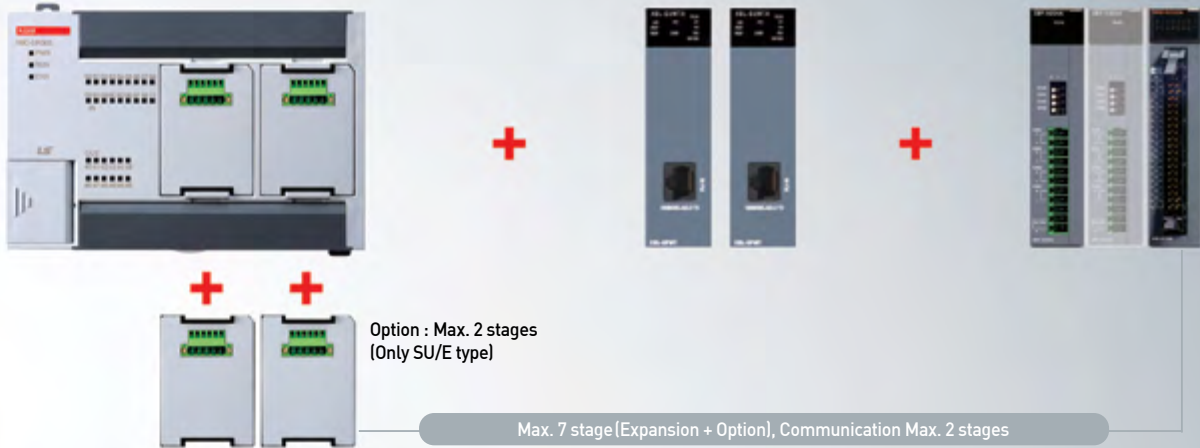

XBC/XEC E



Option modules	
XBO-M2MB	Memory / program READ/WRITE
XBO-RTCA	RTC (Real time clock), Battery
XBO-DC04A	DC 24V, Input 4 points
XBO-TN04A	TR (Sink), Output 4 points
XBO-AD02A	Voltage/Current, Input 2ch
XBO-DA02A	Voltage/Current, Output 2ch
XBO-AH02A	Voltage/Current, Input 1ch / Voltage/Current, Output 1ch
XBO-RD01A	RTD (Resistance temperature detector), Input 1ch
XBO-TC02A	TC (Thermo couple), Input 2ch

XBM Slim

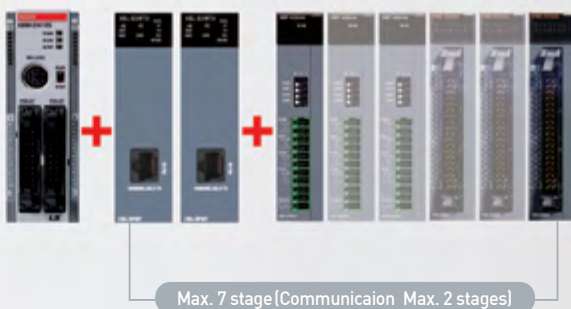

XBM/XEM H, H2, HP

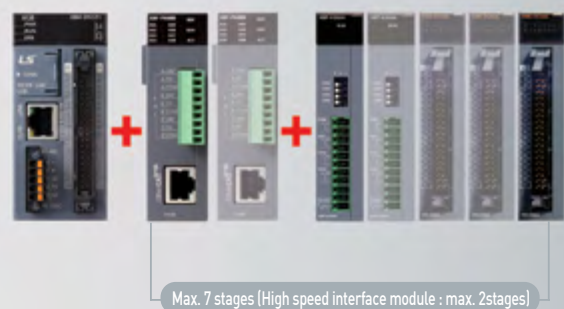



XGB U

Ultimate Performance
Universal IoT
User Oriented

C o n t e n t s

General specifications	18
Performance specifications	19
Wiring	23





Block type unit (U, H, SU, E)



Item	Descriptions			Standard
Ambient temperature	0 ~ 55 °C			
Storage temperature	-25 ~ +70 °C			
Ambient humidity	5 ~ 95%RH (Non-condensing)			
Storage humidity	5 ~ 95%RH (Non-condensing)			
Vibration resistance	Occasional vibration			10 times each direction (X, Y and Z) IEC61131-2
	Frequency	Acceleration	Pulse width	
	10 ≤ f < 57Hz	-	0.075mm	
	57 ≤ f ≤ 150Hz	9.8m/s ² (1G)	-	
	Continuous vibration			
	Frequency	Acceleration	Pulse width	
10 ≤ f < 57Hz	-	0.035mm		
57 ≤ f ≤ 150Hz	4.9m/s ² (0.5G)	-		
Shock resistance	<ul style="list-style-type: none"> • Peak acceleration: 147m/s² (15g) • Duration: 11ms • Pulse waveform: Half-sine, 3times each direction per each axis 			IEC61131-2
Noise resistance	Square wave impulse noise	AC: ±1,500 V DC: ±900V		LS ELECTRIC Standard
	Electrostatic discharge	4kV		IEC61131-2 IEC61000-4-2
	Radiated electromagnetic field noise	80 ~ 1000MHz, 10V/m		IEC61131-2 IEC61000-4-3
	Fast transient/ Burst noise	Main unit	Expansion module	
2kV		1kV		
Operating ambience	Free from corrosive gases and excessive dust			
Altitude	Up to 2,000m			
Pollution level ^{*1)}	Less than 2			
Cooling	Air-cooling			

*1) Pollution level indicates the degree to which conductive material is generated in the environment where the equipment is used. Pollution level 2 is the condition that only non-conductive pollution occurred but temporary conductivity may be produced due to condensing.

Performance specifications | Block type unit

XBC U

Performance specifications

Item	Specifications						Remark
	XBC-DN(P)32U	XBC-DR28U	XBC-DN(P)32UA	XBC-DR28UA	XBC-DN(P)32UP	XBC-DR28UP	
	XBC-DN(P)32U/DC	XBC-DR28U/DC	XBC-DN(P)32UA/DC	XBC-DR28UA/DC	XBC-DN(P)32UP/DC	XBC-DR28UP/DC	
Program control method	Cyclic execution of stored program, Time-driven interrupt, Process-driven interrupt						
I/O control method	Batch processing by simultaneous scan (Refresh method), Directed by program instruction						
Program language	Ladder Diagram, Instruction List						
Number of instructions	Basic	28					
	Application	677					
Processing speed (Basic instruction)	60ns/step						
Program capacity	32Kstep						
Max. I/O points	352points	348points	352points	348points	352points	348points	Main + 10 expansions
Data area	P	P00000 ~ P2047F(32,768 point)					Input/Output
	M	M00000 ~ M2047F(32,768 point)					
	K	K00000 ~ K8191F(131,072 point)					
	L	L00000 ~ L4095F (65,536 point)					Link
	F	F00000 ~ F2047F (32,768 point)					Flag
	T	100ms, 10ms, 1ms: T0000 ~ T2047 (2,048 point)					Timer
	C	C000 ~ C2047 (2,048 point)					Counter
	S	S00.00 ~ S127.99					Step
	D	D00000 ~ D19999(20000word)					Data register
	U	U00.00 ~ U0B.31 (384 word)					Analog Data
	Z	Z000~Z127 (128 word)					
File register	R	RAM area 2 block (R0 ~ R16,383)					
		FLASH area : 4 block (128Kbyte)					
Total program	256						
Initial task	Initial task	1					
	Cyclic task	Max 16					
	I/O task	Max 8					
	Internal device task	Max 16					
	High Speed Counter task	Max 8					
Operation mode	RUN, STOP, DEBUG						
Self-diagnosis function	Detects errors of scan time, memory, I/O and power supply						
Program port	USB 1 channel, Ethernet						
Retain data at power failure	Latch area setting in basic parameter						
Internal consumption current	700mA	990mA	780mA	1,040mA	1,250mA	1,550mA	
Weight	571g	630g	683g	732g	673g	722g	

*1) Auto-MDIX (Automatic medium-dependent interface crossover) :
It is the function to automatically detect whether the cable connected to the Ethernet port is peer-to-peer(straight) or cross cable

XEC U

Performance specifications

Item	Specifications						Remark
	XEC-DN(P)32U	XEC-DR28U	XEC-DN(P)32UA	XEC-DR28UA	XEC-DN(P)32UP	XEC-DR28UP	
	XEC-DN(P)32U/DC	XEC-DR28U/DC	XEC-DN(P)32UA/DC	XEC-DR28UA/DC	XEC-DN(P)32UP/DC	XEC-DR28UP/DC	
Program control method	Cyclic execution of stored program, Time-driven interrupt, Process-driven interrupt						
I/O control method	Batch processing by simultaneous scan (Refresh method), Directed by program instruction						
Program language	Ladder Diagram, Instruction List, SFC, ST						
Number of instructions	Operator	18					
	Basic function	136 + Floating-point Arithmetic Functions					
	Basic function block	43					
	Special function block	Each special module has own special function blocks					
Processing speed (Basic instruction)	60ns/step						
Program memory	384Kbyte						
Max. I/O points	352points	348points	352points	348points	352points	348points	Main + 10 expansions
Data area	Symbolic variable(A)	64KB (Retain setting available)					
	Input variable(I)	2KB					
	Output variable(Q)	2KB					
	Direct variable	M	32KB (Retain setting available)				
		R	32KB * 2blocks				
		W	64KB				Same area with R
	Flag variable	F	4KB				System flag
		K	16KB				Keep relay
		L	8KB				Link relay
		U	768 Byte				Analog data refresh area
N		20KB				P2P parameter	
Flash area	4blocks (128Kbyte)					Using R device	
Timer	No limit in points (Time range: 0.001~ 4,294,967.295)						
Counter	No limit in points (Counter range: 64 bit range)						
Total program	256						
Initial task	Initial task	1					
	Cyclic task	Max 16					
	Initial task	1					
	Cyclic task	Max 16					
	I/O task	Max 8					
	Internal device task	Max 16					
	High Speed Counter task	Max 8					
Operation mode	RUN, STOP, DEBUG						
Self-diagnosis function	Detects errors of scan time, memory, I/O and power supply						
Program port	USB 1 channel						
Retain data at power failure	Latch area setting in basic parameter						
Internal consumption current	700mA	990mA	780mA	1,040mA	1,250mA	1,550mA	
Weight	571g	630g	683g	732g	673g	722g	

Built-in function

Item		Specifications					Remark	
		XBC/XEC-DN(P)32U	XBC/XEC-DR28U	XBC/XEC-DN(P)32UA	XBC/XEC-DR28UA	XBC/XEC-DN(P)32UP		XBC/XEC-DR28UP
		XBC/XEC-DN(P)32U/DC	XBC/XEC-DR28U/DC	XEC-DN(P)32UP/DC	XBC/XEC-DR28UA/DC	XBC/XEC-DN(P)32UP/DC		XBC/XEC-DR28UP/DC
PID control		Control by instruction, auto-tuning, PWM output, Forced output, Operation scan time setting, Antiwindup, Delta MV, PV tracking, Hybrid operation, Cascade operation						
Seria	Protocol	Dedicated protocol, Modbus protocol, User defined protocol, LS bus(inverter protocol)					Embedded00 P2P:01	
	Channel	RS-232C 1 port and RS-485 1 port						
Ethernet	Transfer spec	Cable: 100Base-TX Speed: 100Mbps Auto-MDIX *1 IEEE 802.3						
	Topology	Line, star						
	Diagnosis	Module information, service condition						
	Protocol	XGT dedicated Modbus TCP/IP user define frame					Embedded01 P2P:02 High-speed link:01	
	Service	P2P, High Speed link, Remote connection						
Datalog	Group	Max 10 group						
	Data set	32 per group						
	Extension	csv file						
	File size	Max 16Mbyte						
	SD memory type	SD,SDHC type(Recommmand: SanDisk,Transcend)						
	Memory size	Max 16GB						
	File system	FAT32						
High Speed Counter	Performance	1-phase : 100KHz 8 channels 2-phase : 50KHz 4 channels						
	Counter mode	4 counter modes are supported based on input pulse and INC/DEC method <ul style="list-style-type: none"> • 1 pulse operation Mode : INC/DEC count by program • 1 pulse operation Mode : INC/DEC count by phase B pulse input • 2 pulse operation Mode : INC/DEC count by input pulse • 2 pulse operation Mode : INC/DEC count by difference of phase 						
	Function	<ul style="list-style-type: none"> •Internal/external preset • Latch counter •Compare output • No. of rotation per unit time 						

*1) Auto-MDIX(Automatic medium-dependent interface crossover) : It is the function to automatically detect whether the cable connected to the Ethernet port is peer-to-peer(straight) or cross cable

XEC U

Positioning

Item	Specifications	Remark
Basic Function	No. of control axis: 4axis Control Method: Position, Speed, Speed/Position, Feed Control Control Unit: Pulse, mm, inch, degree Positioning Data: Each axis can have up to 400 data (Step number: 1~400) Operation pattern: End, Keep, Continuous Operation method: Singular, Repeat	Available On UP type
interpolation	2/3/4 axis linear interpolation 2 axis circular interpolation 3 axis helical interpolation	
Positioning	Method: Absolute/Incremental method Address range: 2, 147, 483, 648~2, 147, 483, 647 Speed: Max 2Mpps (1~2,000,000pps) Acc /Dec process: Trapezoid type, S-type	
Homing method	DOG+HOME(Off), DOG+HOME(On), Upper limit + HOME, DOG, High speed, Upper/Lower limit, HOME	
Manual operation	Jog operation, MPG operation, Inching operation	
Encoder input	Line drive (RS-422A) input 1 Channel (Max 200kpps)	

Analog

Item	Specifications	Remark			
Analog input	Channels	4 channels (current/voltage)	Available On UP type		
	Specification	Input Range		Voltage: 1~5V, 0~5V, 0~10V, -10~10V, Current: 4~20mA, 0~20mA Current input or Voltage input can be selected through the external terminal wiring setting.	
		Input resistance		1MΩ or more (voltage input), 250Ω (current input)	
		Max. Resolution		1/16000	
				0.250mV (1~5V), 0.3125mV (0~5V) 0.625mV (0~10V), 1.250mV (±10V)	1.0μA (4~20mA) 1.25μA (0~20mA)
		Accuracy		±0.2% or less (When ambient temperature is 25°C) ±0.3% or less (When ambient temperature is 0~55°C)	
Analog output	Channels	Voltage 2 channels, Current 2 channels	Available On UP type		
	Specification	Output Range		Voltage: 1~5V, 0~5V, 0~10V, -10~10V, Current: 4~20mA, 0~20mA Output ranges are set in user program or I/O parameter per each channel.	
		Load resistance		1MΩ or more (voltage output), 600Ω or less (current output)	
		Max. Resolution		1/16000	
				0.250mV (1~5V), 0.3125mV (0~5V) 0.625mV (0~10V), 1.250mV (±10V)	1.0μA (4~20mA) 1.25μA (0~20mA)
		Accuracy		±0.2% or less (When ambient temperature is 25°C) ±0.3% or less (When ambient temperature is 0~55°C)	

XBC-DN(P)32U/DC (16 point input)

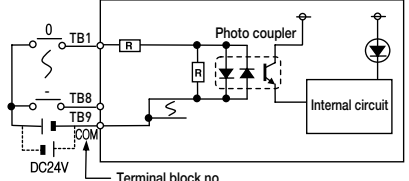

DC24V
Terminal block no.

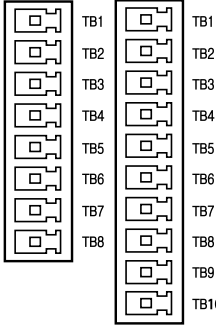
Circuit configuration		No.	Contact	No.	Contact	Type
		TB1	0	TB1	8	
		TB2	1	TB2	9	
		TB3	2	TB3	A	
		TB4	3	TB4	B	
		TB5	4	TB5	C	
		TB6	5	TB6	D	
		TB7	6	TB7	E	
		TB8	7	TB8	F	
				TB9	COM	
				TB10	COM	

XBC-DN32U/DC Transistor output (Sink type)

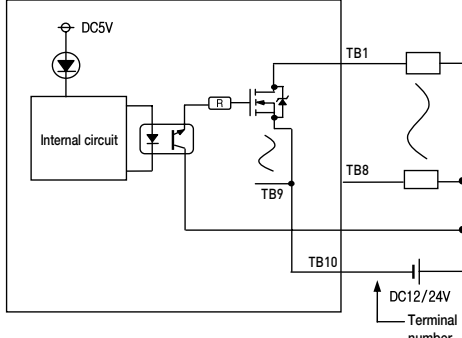

DC5V
Internal circuit
R
Photo coupler
TB1
TB8
TB9
TB10
DC12/24V
Terminal number

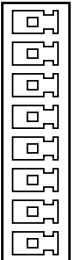
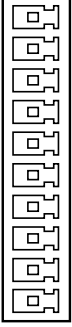
Circuit configuration		No.	Contact	Type
		TB1	0	
		TB2	1	
		TB3	2	
		TB4	3	
		TB5	4	
		TB6	5	
		TB7	6	
		TB8	7	
		TB1	8	
		TB2	9	
		TB3	A	
		TB4	B	
		TB5	C	
		TB6	D	
		TB7	E	
		TB8	F	
		TB9	DC12/24V	
		TB10	COM	

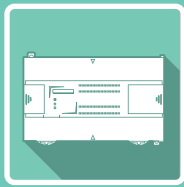

XBC/XEC H

High Performance

C o n t e n t s

Performance specifications26

Wiring27





High performance type

Performance specifications

Item	XBC/XEC-DR32H	XBC/XEC-DN32H	XBC/XEC-DR64H	XBC/XEC-DN64H
	XBC-DR32H/DC ^{*1)}	XEC-DP32H ^{*1)}	XBC-DR64H/DC ^{*1)}	XEC-DP64H ^{*1)}
	XEC-DR32H/DI	XBC-DN32H/DC	XEC-DR64H/DI	XBC-DN64H/DC
Control method	Repetitive, cyclic, interrupt, constant scan			
I/O control method	Refresh mode (Batch processing by scan synchronization), Direct mode by instruction			
Programming language	Ladder diagram or IEC standard (LD, SFC, ST) ^{*1)}			
Processing speed	83 ns / Step			
Program capacity	15Kstep (IEC type: 200KB)			
Main unit I/O points	32 (Input:16, Output:16)	32 (Input:16, Output:16)	64 (Input: 32, Output: 32)	64 (Input: 32, Output: 32)
Max. I/O points (Main + Expansion 10 stages)	352 points		384 points	
Total program	128			
Operation mode	RUN, STOP, DEBUG			
Self diagnosis	Detects errors of scan time, memory error, I/O error, battery error, power error, etc.			
Program port	USB (Rev 1.1), RS-232C 1 channel (Loader)			
Retain data at power failure	Latch area setting at basic parameter			
Built-in functions	RS-232C / RS-485 (2 ch), Pulse catch, Input filter, External interrupt, PID control, High-speed counter, Positioning, RTC			
Data memory				
XBC		XEC (IEC type)		
P	P0000 ~ P1023F (16,384 points)	Symbolic variable	A	32KB (Max. 16KB retain setting available)
M	M0000 ~ M1023F (16,384 points)	Input variable	I	2KB (%IX 15.15.63)
K	K0000 ~ K4095F (65,536 points)	Output variable	Q	2KB (%QX 15.15.63)
L	L0000 ~ L2047F (32,768 points)	Direct variable	M	16KB (Max. 8KB retain setting available)
F	F0000 ~ F1023F (16,384 points)		R	20KB (1 block)
T	100ms, 10ms, 1ms: T0000 ~ T1023 (1,024)(Adjustable by parameter setting)		W	20KB
C	C0000 ~ C1023 (1,024)	Flag variable	F	2KB
S	S00.00 ~ S127.99		K	8KB
D	D0000 ~ D10239 (10,240 word)		L	4KB
U	U00.00 ~ U0A.31 (Analog data refresh area: 352 word)		N	10KB
Z	Z000 ~ Z127 (128 word)		U	1KB
N	N000 ~ N5119 (5,120 word)	Flash area	R	20KB (2 blocks)

^{*1)} XEC is IEC standard language programming.

Wiring | XBC/XEC H input/output wiring

XBC/XEC-DN(R)32H XBC/XEC-DN/DR/DP32H Input wiring (sink/source type)

Terminal block no.

No.	Contact	No.	Contact	Type																																																																								
TB2	485+	TB1	RX	<table border="1" style="width: 100%; border-collapse: collapse;"> <tr><td>TB1</td><td>RX</td><td>TB1</td></tr> <tr><td>TB3</td><td>TX</td><td>TB3</td></tr> <tr><td>TB5</td><td>SG</td><td>TB5</td></tr> <tr><td>TB7</td><td>01</td><td>TB7</td></tr> <tr><td>TB9</td><td>03</td><td>TB9</td></tr> <tr><td>TB11</td><td>05</td><td>TB11</td></tr> <tr><td>TB13</td><td>07</td><td>TB13</td></tr> <tr><td>TB15</td><td>09</td><td>TB15</td></tr> <tr><td>TB17</td><td>0B</td><td>TB17</td></tr> <tr><td>TB19</td><td>0D</td><td>TB19</td></tr> <tr><td>TB21</td><td>0F</td><td>TB21</td></tr> <tr><td>TB23</td><td>24G</td><td>TB23</td></tr> <tr><td>TB2</td><td>485+</td><td>TB2</td></tr> <tr><td>TB4</td><td>485-</td><td>TB4</td></tr> <tr><td>TB6</td><td>00</td><td>TB6</td></tr> <tr><td>TB8</td><td>02</td><td>TB8</td></tr> <tr><td>TB10</td><td>04</td><td>TB10</td></tr> <tr><td>TB12</td><td>06</td><td>TB12</td></tr> <tr><td>TB14</td><td>08</td><td>TB14</td></tr> <tr><td>TB16</td><td>0A</td><td>TB16</td></tr> <tr><td>TB18</td><td>0C</td><td>TB18</td></tr> <tr><td>TB20</td><td>0E</td><td>TB20</td></tr> <tr><td>TB22</td><td>COM</td><td>TB22</td></tr> <tr><td>TB24</td><td>24V</td><td>TB24</td></tr> </table>	TB1	RX	TB1	TB3	TX	TB3	TB5	SG	TB5	TB7	01	TB7	TB9	03	TB9	TB11	05	TB11	TB13	07	TB13	TB15	09	TB15	TB17	0B	TB17	TB19	0D	TB19	TB21	0F	TB21	TB23	24G	TB23	TB2	485+	TB2	TB4	485-	TB4	TB6	00	TB6	TB8	02	TB8	TB10	04	TB10	TB12	06	TB12	TB14	08	TB14	TB16	0A	TB16	TB18	0C	TB18	TB20	0E	TB20	TB22	COM	TB22	TB24	24V	TB24
TB1	RX	TB1																																																																										
TB3	TX	TB3																																																																										
TB5	SG	TB5																																																																										
TB7	01	TB7																																																																										
TB9	03	TB9																																																																										
TB11	05	TB11																																																																										
TB13	07	TB13																																																																										
TB15	09	TB15																																																																										
TB17	0B	TB17																																																																										
TB19	0D	TB19																																																																										
TB21	0F	TB21																																																																										
TB23	24G	TB23																																																																										
TB2	485+	TB2																																																																										
TB4	485-	TB4																																																																										
TB6	00	TB6																																																																										
TB8	02	TB8																																																																										
TB10	04	TB10																																																																										
TB12	06	TB12																																																																										
TB14	08	TB14																																																																										
TB16	0A	TB16																																																																										
TB18	0C	TB18																																																																										
TB20	0E	TB20																																																																										
TB22	COM	TB22																																																																										
TB24	24V	TB24																																																																										
TB4	485-	TB3	TX																																																																									
TB6	00	TB5	SG																																																																									
TB8	02	TB7	01																																																																									
TB10	04	TB9	03																																																																									
TB12	06	TB11	05																																																																									
TB14	08	TB13	07																																																																									
TB16	0A	TB15	09																																																																									
TB18	0C	TB17	0B																																																																									
TB20	0E	TB19	0D																																																																									
TB22	COM	TB21	0F																																																																									
TB24	24V	TB23	24G																																																																									

XBC/XEC-DR32H Relay output wiring type

Terminal block no.

No.	Contact	No.	Contact	Type																																																																								
TB2	PE	TB1	Power	<table border="1" style="width: 100%; border-collapse: collapse;"> <tr><td>TB1</td><td>AC100~240V</td><td>TB1</td></tr> <tr><td>TB3</td><td>20</td><td>TB3</td></tr> <tr><td>TB5</td><td>22</td><td>TB5</td></tr> <tr><td>TB7</td><td>COM0</td><td>TB7</td></tr> <tr><td>TB9</td><td>25</td><td>TB9</td></tr> <tr><td>TB11</td><td>27</td><td>TB11</td></tr> <tr><td>TB13</td><td>28</td><td>TB13</td></tr> <tr><td>TB15</td><td>2A</td><td>TB15</td></tr> <tr><td>TB17</td><td>COM2</td><td>TB17</td></tr> <tr><td>TB19</td><td>2D</td><td>TB19</td></tr> <tr><td>TB21</td><td>2F</td><td>TB21</td></tr> <tr><td>TB23</td><td>2F</td><td>TB23</td></tr> <tr><td>TB2</td><td>PE</td><td>TB2</td></tr> <tr><td>TB4</td><td>NC</td><td>TB4</td></tr> <tr><td>TB6</td><td>21</td><td>TB6</td></tr> <tr><td>TB8</td><td>23</td><td>TB8</td></tr> <tr><td>TB10</td><td>24</td><td>TB10</td></tr> <tr><td>TB12</td><td>26</td><td>TB12</td></tr> <tr><td>TB14</td><td>COM1</td><td>TB14</td></tr> <tr><td>TB16</td><td>29</td><td>TB16</td></tr> <tr><td>TB18</td><td>28</td><td>TB18</td></tr> <tr><td>TB20</td><td>2C</td><td>TB20</td></tr> <tr><td>TB22</td><td>2E</td><td>TB22</td></tr> <tr><td>TB24</td><td>COM3</td><td>TB24</td></tr> </table>	TB1	AC100~240V	TB1	TB3	20	TB3	TB5	22	TB5	TB7	COM0	TB7	TB9	25	TB9	TB11	27	TB11	TB13	28	TB13	TB15	2A	TB15	TB17	COM2	TB17	TB19	2D	TB19	TB21	2F	TB21	TB23	2F	TB23	TB2	PE	TB2	TB4	NC	TB4	TB6	21	TB6	TB8	23	TB8	TB10	24	TB10	TB12	26	TB12	TB14	COM1	TB14	TB16	29	TB16	TB18	28	TB18	TB20	2C	TB20	TB22	2E	TB22	TB24	COM3	TB24
TB1	AC100~240V	TB1																																																																										
TB3	20	TB3																																																																										
TB5	22	TB5																																																																										
TB7	COM0	TB7																																																																										
TB9	25	TB9																																																																										
TB11	27	TB11																																																																										
TB13	28	TB13																																																																										
TB15	2A	TB15																																																																										
TB17	COM2	TB17																																																																										
TB19	2D	TB19																																																																										
TB21	2F	TB21																																																																										
TB23	2F	TB23																																																																										
TB2	PE	TB2																																																																										
TB4	NC	TB4																																																																										
TB6	21	TB6																																																																										
TB8	23	TB8																																																																										
TB10	24	TB10																																																																										
TB12	26	TB12																																																																										
TB14	COM1	TB14																																																																										
TB16	29	TB16																																																																										
TB18	28	TB18																																																																										
TB20	2C	TB20																																																																										
TB22	2E	TB22																																																																										
TB24	COM3	TB24																																																																										
TB4	NC	TB3	Power																																																																									
TB6	21	TB5	20																																																																									
TB8	23	TB7	22																																																																									
TB10	24	TB9	COM0																																																																									
TB12	26	TB11	25																																																																									
TB14	COM1	TB13	27																																																																									
TB16	29	TB15	28																																																																									
TB18	28	TB17	2A																																																																									
TB20	2C	TB19	COM2																																																																									
TB22	2E	TB21	2D																																																																									
TB24	COM3	TB23	2F																																																																									

XBC/XEC-DN32H Transistor output wiring (sink type)

Terminal block no.

No.	Contact	No.	Contact	Type																																																																								
TB2	PE	TB1	Power	<table border="1" style="width: 100%; border-collapse: collapse;"> <tr><td>TB1</td><td>AC100~240V</td><td>TB1</td></tr> <tr><td>TB3</td><td>20</td><td>TB3</td></tr> <tr><td>TB5</td><td>22</td><td>TB5</td></tr> <tr><td>TB7</td><td>COM0</td><td>TB7</td></tr> <tr><td>TB9</td><td>25</td><td>TB9</td></tr> <tr><td>TB11</td><td>27</td><td>TB11</td></tr> <tr><td>TB13</td><td>28</td><td>TB13</td></tr> <tr><td>TB15</td><td>2A</td><td>TB15</td></tr> <tr><td>TB17</td><td>COM2</td><td>TB17</td></tr> <tr><td>TB19</td><td>2D</td><td>TB19</td></tr> <tr><td>TB21</td><td>2F</td><td>TB21</td></tr> <tr><td>TB23</td><td>2F</td><td>TB23</td></tr> <tr><td>TB2</td><td>PE</td><td>TB2</td></tr> <tr><td>TB4</td><td>DC12/24V</td><td>TB4</td></tr> <tr><td>TB6</td><td>21</td><td>TB6</td></tr> <tr><td>TB8</td><td>23</td><td>TB8</td></tr> <tr><td>TB10</td><td>24</td><td>TB10</td></tr> <tr><td>TB12</td><td>26</td><td>TB12</td></tr> <tr><td>TB14</td><td>COM1</td><td>TB14</td></tr> <tr><td>TB16</td><td>29</td><td>TB16</td></tr> <tr><td>TB18</td><td>28</td><td>TB18</td></tr> <tr><td>TB20</td><td>2C</td><td>TB20</td></tr> <tr><td>TB22</td><td>2E</td><td>TB22</td></tr> <tr><td>TB24</td><td>COM3</td><td>TB24</td></tr> </table>	TB1	AC100~240V	TB1	TB3	20	TB3	TB5	22	TB5	TB7	COM0	TB7	TB9	25	TB9	TB11	27	TB11	TB13	28	TB13	TB15	2A	TB15	TB17	COM2	TB17	TB19	2D	TB19	TB21	2F	TB21	TB23	2F	TB23	TB2	PE	TB2	TB4	DC12/24V	TB4	TB6	21	TB6	TB8	23	TB8	TB10	24	TB10	TB12	26	TB12	TB14	COM1	TB14	TB16	29	TB16	TB18	28	TB18	TB20	2C	TB20	TB22	2E	TB22	TB24	COM3	TB24
TB1	AC100~240V	TB1																																																																										
TB3	20	TB3																																																																										
TB5	22	TB5																																																																										
TB7	COM0	TB7																																																																										
TB9	25	TB9																																																																										
TB11	27	TB11																																																																										
TB13	28	TB13																																																																										
TB15	2A	TB15																																																																										
TB17	COM2	TB17																																																																										
TB19	2D	TB19																																																																										
TB21	2F	TB21																																																																										
TB23	2F	TB23																																																																										
TB2	PE	TB2																																																																										
TB4	DC12/24V	TB4																																																																										
TB6	21	TB6																																																																										
TB8	23	TB8																																																																										
TB10	24	TB10																																																																										
TB12	26	TB12																																																																										
TB14	COM1	TB14																																																																										
TB16	29	TB16																																																																										
TB18	28	TB18																																																																										
TB20	2C	TB20																																																																										
TB22	2E	TB22																																																																										
TB24	COM3	TB24																																																																										
TB4	DC12/24V	TB3	Power																																																																									
TB6	21	TB5	20																																																																									
TB8	23	TB7	22																																																																									
TB10	24	TB9	COM0																																																																									
TB12	26	TB11	25																																																																									
TB14	COM1	TB13	27																																																																									
TB16	29	TB15	28																																																																									
TB18	28	TB17	2A																																																																									
TB20	2C	TB19	COM2																																																																									
TB22	2E	TB21	2D																																																																									
TB24	COM3	TB23	2F																																																																									

* XBC input : P00~P1F, XEC input : I00~I31 * XBC output : P21~P3F, XEC output : Q00~Q31

XEC-DP32H

Transistor output wiring
(source type)

Circuit configuration		No.	Contact	No.	Contact	Type
	TB2	PE	TB1	Power		
	TB4	DC12/24V	TB3	20		
	TB6	21	TB7	22		
	TB8	23	TB9	COM0		
	TB10	24	TB11	25		
	TB12	26	TB13	27		
	TB14	COM1	TB15	28		
	TB16	29	TB17	2A		
	TB18	28	TB19	COM2		
	TB20	2C	TB21	2D		
	TB22	2E	TB23	2F		
	TB24	COM3				

XBC-DN(R)64H

XEC-DN/DR/DP64H
Input wiring
(sink/source type)

Circuit configuration		No.	Contact	No.	Contact	Type
	TB2	485+	TB1	RX		
	TB4	485-	TB3	TX		
	TB6	00	TB5	SG		
	TB8	02	TB7	01		
	TB10	04	TB9	03		
	TB12	06	TB11	05		
	TB14	08	TB13	07		
	TB16	0A	TB15	09		
	TB18	00	TB17	0B		
	TB20	0E	TB19	0D		
	TB22	COM0	TB23	0F		
	TB24	10	TB25	MC		
	TB26	12	TB27	11		
	TB28	14	TB29	13		
	TB30	16	TB31	15		
	TB32	18	TB33	17		
	TB34	1A	TB35	19		
	TB36	1C	TB37	1D		
	TB38	1E	TB39	1F		
	TB40	COM1	TB41	24G		
	TB42	24V				

XBC-DR60H

XEC-DR64H

Relay output wiring

Circuit configuration		No.	Contact	No.	Contact	Type
	TB2	PE	TB1	Power		
	TB4	NC	TB3	20		
	TB6	21	TB7	22		
	TB8	23	TB9	COM0		
	TB10	24	TB11	25		
	TB12	26	TB13	27		
	TB14	COM1	TB15	28		
	TB16	29	TB17	2A		
	TB18	2B	TB19	COM2		
	TB20	2C	TB21	2D		
	TB22	2E	TB23	2F		
	TB24	COM2	TB25	30		
	TB26	31	TB27	32		
	TB28	33	TB29	34		
	TB30	35	TB31	36		
	TB32	37	TB33	COM4		
	TB34	38	TB35	39		
	TB36	3A	TB37	38		
	TB38	3C	TB39	3D		
	TB40	3E	TB41	3F		
	TB42	COM5				

* XBC input : P00~P1F, XEC input : I00~I31 * XBC output : P21~P3F, XEC output : Q00~Q31

XBC-DP64H

Transistor output wiring
(sink type)

Circuit configuration	No.	Contact	No.	Contact	Type																																																																		
	TB2	PE	TB1	Power	<table border="1"> <tr> <td>⊕</td> <td>AC100</td> <td>TB1</td> </tr> <tr> <td>⊖</td> <td>-240V</td> <td>TB3</td> </tr> <tr> <td>01</td> <td>00</td> <td>TB5</td> </tr> <tr> <td>02</td> <td>02</td> <td>TB7</td> </tr> <tr> <td>03</td> <td>02</td> <td>TB9</td> </tr> <tr> <td>04</td> <td>COM0</td> <td>TB11</td> </tr> <tr> <td>05</td> <td>05</td> <td>TB13</td> </tr> <tr> <td>06</td> <td>07</td> <td>TB15</td> </tr> <tr> <td>07</td> <td>08</td> <td>TB17</td> </tr> <tr> <td>08</td> <td>10</td> <td>TB19</td> </tr> <tr> <td>09</td> <td>COM2</td> <td>TB21</td> </tr> <tr> <td>10</td> <td>13</td> <td>TB23</td> </tr> <tr> <td>11</td> <td>15</td> <td>TB25</td> </tr> <tr> <td>12</td> <td>16</td> <td>TB27</td> </tr> <tr> <td>13</td> <td>18</td> <td>TB29</td> </tr> <tr> <td>14</td> <td>20</td> <td>TB31</td> </tr> <tr> <td>15</td> <td>22</td> <td>TB33</td> </tr> <tr> <td>16</td> <td>25</td> <td>TB35</td> </tr> <tr> <td>17</td> <td>27</td> <td>TB37</td> </tr> <tr> <td>18</td> <td>29</td> <td>TB39</td> </tr> <tr> <td>19</td> <td>31</td> <td>TB41</td> </tr> <tr> <td>20</td> <td>⊕</td> <td></td> </tr> </table>	⊕	AC100	TB1	⊖	-240V	TB3	01	00	TB5	02	02	TB7	03	02	TB9	04	COM0	TB11	05	05	TB13	06	07	TB15	07	08	TB17	08	10	TB19	09	COM2	TB21	10	13	TB23	11	15	TB25	12	16	TB27	13	18	TB29	14	20	TB31	15	22	TB33	16	25	TB35	17	27	TB37	18	29	TB39	19	31	TB41	20	⊕	
	⊕	AC100	TB1																																																																				
	⊖	-240V	TB3																																																																				
	01	00	TB5																																																																				
	02	02	TB7																																																																				
	03	02	TB9																																																																				
	04	COM0	TB11																																																																				
	05	05	TB13																																																																				
	06	07	TB15																																																																				
	07	08	TB17																																																																				
	08	10	TB19																																																																				
	09	COM2	TB21																																																																				
	10	13	TB23																																																																				
	11	15	TB25																																																																				
	12	16	TB27																																																																				
	13	18	TB29																																																																				
	14	20	TB31																																																																				
	15	22	TB33																																																																				
	16	25	TB35																																																																				
	17	27	TB37																																																																				
	18	29	TB39																																																																				
19	31	TB41																																																																					
20	⊕																																																																						
TB4	DC12/24V	TB3																																																																					
TB6	21	TB5	20																																																																				
TB8	23	TB7	22																																																																				
TB10	24	TB9	COM0																																																																				
TB12	26	TB11	25																																																																				
TB14	COM1	TB13	27																																																																				
TB16	29	TB15	28																																																																				
TB18	2B	TB17	2A																																																																				
TB20	2C	TB19	COM2																																																																				
TB22	2E	TB21	2D																																																																				
TB24	COM2	TB23	2F																																																																				
TB26	31	TB25	30																																																																				
TB28	33	TB27	32																																																																				
TB30	35	TB29	34																																																																				
TB32	37	TB31	36																																																																				
TB34	38	TB33	COM4																																																																				
TB36	3A	TB35	39																																																																				
TB38	3C	TB37	38																																																																				
TB40	3E	TB39	3D																																																																				
TB42	COM5	TB41	3F																																																																				

XBC-DP64H

Transistor output wiring
(source type)

Circuit configuration	No.	Contact	No.	Contact	Type																																																																		
	TB2	PE	TB1	Power	<table border="1"> <tr> <td>⊕</td> <td>AC100</td> <td>TB1</td> </tr> <tr> <td>⊖</td> <td>-240V</td> <td>TB3</td> </tr> <tr> <td>01</td> <td>00</td> <td>TB5</td> </tr> <tr> <td>02</td> <td>02</td> <td>TB7</td> </tr> <tr> <td>03</td> <td>02</td> <td>TB9</td> </tr> <tr> <td>04</td> <td>COM0</td> <td>TB11</td> </tr> <tr> <td>05</td> <td>05</td> <td>TB13</td> </tr> <tr> <td>06</td> <td>07</td> <td>TB15</td> </tr> <tr> <td>07</td> <td>08</td> <td>TB17</td> </tr> <tr> <td>08</td> <td>10</td> <td>TB19</td> </tr> <tr> <td>09</td> <td>COM2</td> <td>TB21</td> </tr> <tr> <td>10</td> <td>13</td> <td>TB23</td> </tr> <tr> <td>11</td> <td>15</td> <td>TB25</td> </tr> <tr> <td>12</td> <td>16</td> <td>TB27</td> </tr> <tr> <td>13</td> <td>18</td> <td>TB29</td> </tr> <tr> <td>14</td> <td>20</td> <td>TB31</td> </tr> <tr> <td>15</td> <td>22</td> <td>TB33</td> </tr> <tr> <td>16</td> <td>25</td> <td>TB35</td> </tr> <tr> <td>17</td> <td>27</td> <td>TB37</td> </tr> <tr> <td>18</td> <td>29</td> <td>TB39</td> </tr> <tr> <td>19</td> <td>31</td> <td>TB41</td> </tr> <tr> <td>20</td> <td>⊕</td> <td></td> </tr> </table>	⊕	AC100	TB1	⊖	-240V	TB3	01	00	TB5	02	02	TB7	03	02	TB9	04	COM0	TB11	05	05	TB13	06	07	TB15	07	08	TB17	08	10	TB19	09	COM2	TB21	10	13	TB23	11	15	TB25	12	16	TB27	13	18	TB29	14	20	TB31	15	22	TB33	16	25	TB35	17	27	TB37	18	29	TB39	19	31	TB41	20	⊕	
	⊕	AC100	TB1																																																																				
	⊖	-240V	TB3																																																																				
	01	00	TB5																																																																				
	02	02	TB7																																																																				
	03	02	TB9																																																																				
	04	COM0	TB11																																																																				
	05	05	TB13																																																																				
	06	07	TB15																																																																				
	07	08	TB17																																																																				
	08	10	TB19																																																																				
	09	COM2	TB21																																																																				
	10	13	TB23																																																																				
	11	15	TB25																																																																				
	12	16	TB27																																																																				
	13	18	TB29																																																																				
	14	20	TB31																																																																				
	15	22	TB33																																																																				
	16	25	TB35																																																																				
	17	27	TB37																																																																				
	18	29	TB39																																																																				
19	31	TB41																																																																					
20	⊕																																																																						
TB4	DC12/24V	TB3																																																																					
TB6	21	TB5	20																																																																				
TB8	23	TB7	22																																																																				
TB10	24	TB9	COM0																																																																				
TB12	26	TB11	25																																																																				
TB14	COM1	TB13	27																																																																				
TB16	29	TB15	28																																																																				
TB18	2B	TB17	2A																																																																				
TB20	2C	TB19	COM2																																																																				
TB22	2E	TB21	2D																																																																				
TB24	COM2	TB23	2F																																																																				
TB26	31	TB25	30																																																																				
TB28	33	TB27	32																																																																				
TB30	35	TB29	34																																																																				
TB32	37	TB31	36																																																																				
TB34	38	TB33	COM4																																																																				
TB36	3A	TB35	39																																																																				
TB38	3C	TB37	38																																																																				
TB40	3E	TB39	3D																																																																				
TB42	COM5	TB41	3F																																																																				

* XBC input : P00~P1F, XEC input : I00~I31 * XBC output : P21~P3F, XEC output : Q00~Q31

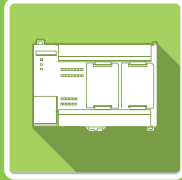

XBC/XEC SU

Standard

C o n t e n t s

Performance specifications32

Wiring33

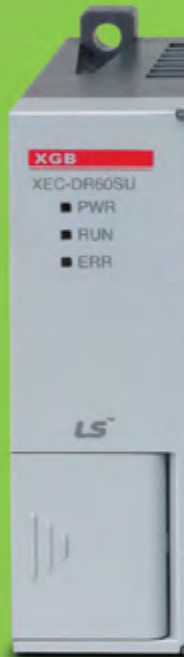

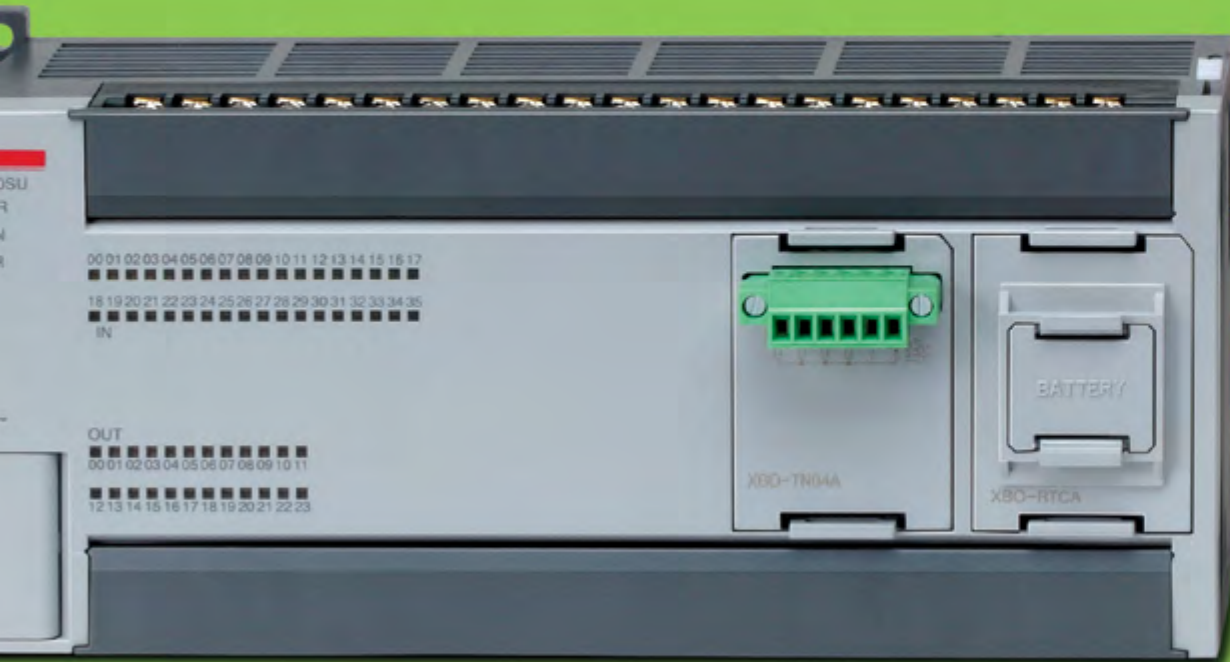

Standard type

Performance specifications

Item	XBC/XEC-DN20SU	XBC/XEC-DN30SU	XBC/XEC-DN40SU	XBC/XEC-DN60SU		
	XBC/XEC-DR20SU	XBC/XEC-DR30SU	XBC/XEC-DR40SU	XBC/XEC-DR60SU		
	XBC/XEC-DP20SU	XBC/XEC-DP30SU	XBC/XEC-DP40SU	XBC/XEC-DP60SU		
Control method	Repetitive, cyclic, interrupt, constant scan					
I/O control method	Refresh mode (Batch processing by scan synchronization), Direct mode by instruction					
Programming language	Ladder diagram, Instruction List					
Processing speed	94 ns / Step					
Program capacity	15Kstep / 200KB					
Main unit I/O points	20 (Input:12, Output:8)	30 (Input:18, Output:12)	40 (Input:24, Output:16)	60 (Input:36, Output:24)		
Max. I/O points (Main + Expansion 7 stages)	244 points	254 points	264 points	284 points		
Total program	128					
Operation mode	RUN, STOP, DEBUG					
Self diagnosis	Detects errors of scan time, memory error, I/O error, battery error, power error, etc.					
Program port	RS-232C 1 channel (Loader), USB 1 channel (U-type model)					
Retain data at power failure	Latch area setting at basic parameter					
Built-in functions	RS-232C / RS-485(2 ch), Pulse catch, Input filter, External interrupt, PID control, High-speed counter, Positioning					
Data memory						
XBC			XEC			
Data area	P	P0000 ~ P1023F (16,384 points)	Symbolic variable	A	16KB (Max. 16KB retain setting available)	
	M	M0000 ~ M1023F (16,384 points)		Input variable	I	2KB (%IX 15.15.63)
	K	K0000 ~ K4095F (65,536 points)	Output variable		Q	2KB (%QX 15.15.63)
	L	L0000 ~ L2047F (32,768 points)		Direct variable	M	8KB (Max. retain setting available)
	F	F0000 ~ F1023F (16,384 points)	R		20KB (1 block)	
	T	100ms, 10ms, 1ms: T0000 ~ T1023 (1,024) (Adjustable by parameter setting)	W		20KB	
	C	C0000 ~ C1023 (1,024)	Flag variable		F	2KB
	S	S00.00 ~ S127.99		K	8KB	
	D	D0000 ~ D10239 (10,240 word)		L	4KB	
	U	U00.00 ~ U0A.31 (Analog data refresh area: 352 word)		U	1KB	
	Z	Z000 ~ Z127 (128 word)	Flash area		20KB (2 block)	
	R	N0000 ~ N10236 (10,240 word)				

*Some products are due in market soon.

Wiring | XBC/XEC SU input/output wiring

XBC/XEC-DR20SU
XBC/XEC-DN20SU
XBC/XEC-DP20SU
Input wiring
(sink/source type)

Circuit configuration		No.	Contact	No.	Contact	Type																																																								
		TB2	485+	TB1	RX	<table border="1"> <tr><td>⊕</td><td></td><td></td><td></td></tr> <tr><td></td><td>RX</td><td>TB1</td><td></td></tr> <tr><td></td><td>TX</td><td>TB3</td><td></td></tr> <tr><td></td><td>SG</td><td>TB5</td><td></td></tr> <tr><td></td><td>01</td><td>TB7</td><td></td></tr> <tr><td></td><td>03</td><td>TB9</td><td></td></tr> <tr><td></td><td>05</td><td>TB11</td><td></td></tr> <tr><td></td><td>07</td><td>TB13</td><td></td></tr> <tr><td></td><td>09</td><td>TB15</td><td></td></tr> <tr><td></td><td>0B</td><td>TB17</td><td></td></tr> <tr><td></td><td>NC</td><td>TB19</td><td></td></tr> <tr><td></td><td>NC</td><td>TB21</td><td></td></tr> <tr><td></td><td>NC</td><td>TB23</td><td></td></tr> <tr><td></td><td>⊕</td><td></td><td></td></tr> </table>	⊕					RX	TB1			TX	TB3			SG	TB5			01	TB7			03	TB9			05	TB11			07	TB13			09	TB15			0B	TB17			NC	TB19			NC	TB21			NC	TB23			⊕		
		⊕																																																												
			RX	TB1																																																										
			TX	TB3																																																										
			SG	TB5																																																										
			01	TB7																																																										
			03	TB9																																																										
			05	TB11																																																										
			07	TB13																																																										
			09	TB15																																																										
			0B	TB17																																																										
			NC	TB19																																																										
			NC	TB21																																																										
	NC	TB23																																																												
	⊕																																																													
TB4	485-	TB3	TX																																																											
TB6	00	TB5	SG																																																											
TB8	02	TB7	01																																																											
TB10	04	TB9	03																																																											
TB12	06	TB11	05																																																											
TB14	08	TB13	07																																																											
TB16	0A	TB15	09																																																											
TB18	NC	TB17	0B																																																											
TB20	NC	TB19	NC																																																											
TB22	NC	TB21	NC																																																											
TB24	COM	TB23	NC																																																											

XBC/XEC-DR20SU
Relay output wiring

Circuit configuration		No.	Contact	No.	Contact	Type																																																								
		TB2	PE	TB1	AC100	<table border="1"> <tr><td>⊕</td><td></td><td></td><td></td></tr> <tr><td></td><td>AC100</td><td>TB1</td><td></td></tr> <tr><td></td><td>-240V</td><td>TB3</td><td></td></tr> <tr><td></td><td>40</td><td>TB5</td><td></td></tr> <tr><td></td><td>41</td><td>TB7</td><td></td></tr> <tr><td></td><td>42</td><td>TB9</td><td></td></tr> <tr><td></td><td>NC</td><td>TB11</td><td></td></tr> <tr><td></td><td>44</td><td>TB13</td><td></td></tr> <tr><td></td><td>46</td><td>TB15</td><td></td></tr> <tr><td></td><td>NC</td><td>TB17</td><td></td></tr> <tr><td></td><td>NC</td><td>TB19</td><td></td></tr> <tr><td></td><td>NC</td><td>TB21</td><td></td></tr> <tr><td></td><td>24V</td><td>TB23</td><td></td></tr> <tr><td></td><td>⊕</td><td></td><td></td></tr> </table>	⊕					AC100	TB1			-240V	TB3			40	TB5			41	TB7			42	TB9			NC	TB11			44	TB13			46	TB15			NC	TB17			NC	TB19			NC	TB21			24V	TB23			⊕		
		⊕																																																												
			AC100	TB1																																																										
			-240V	TB3																																																										
			40	TB5																																																										
			41	TB7																																																										
			42	TB9																																																										
			NC	TB11																																																										
			44	TB13																																																										
			46	TB15																																																										
			NC	TB17																																																										
			NC	TB19																																																										
			NC	TB21																																																										
	24V	TB23																																																												
	⊕																																																													
TB4	COM0	TB3	-240V																																																											
TB6	COM1	TB5	40																																																											
TB8	COM2	TB7	41																																																											
TB10	43	TB9	42																																																											
TB12	COM3	TB11	NC																																																											
TB14	45	TB13	44																																																											
TB16	47	TB15	46																																																											
TB18	NC	TB17	NC																																																											
TB20	NC	TB19	NC																																																											
TB22	NC	TB21	NC																																																											
TB24	24G	TB23	24V																																																											

XBC/XEC-DN20SU
Transistor output wiring
(sink type)

Circuit configuration		No.	Contact	No.	Contact	Type																																																								
		TB2	PE	TB1	AC100	<table border="1"> <tr><td>⊕</td><td></td><td></td><td></td></tr> <tr><td></td><td>AC100</td><td>TB1</td><td></td></tr> <tr><td></td><td>-240V</td><td>TB3</td><td></td></tr> <tr><td></td><td>40</td><td>TB5</td><td></td></tr> <tr><td></td><td>41</td><td>TB7</td><td></td></tr> <tr><td></td><td>42</td><td>TB9</td><td></td></tr> <tr><td></td><td>P</td><td>TB11</td><td></td></tr> <tr><td></td><td>44</td><td>TB13</td><td></td></tr> <tr><td></td><td>46</td><td>TB15</td><td></td></tr> <tr><td></td><td>NC</td><td>TB17</td><td></td></tr> <tr><td></td><td>NC</td><td>TB19</td><td></td></tr> <tr><td></td><td>NC</td><td>TB21</td><td></td></tr> <tr><td></td><td>24V</td><td>TB23</td><td></td></tr> <tr><td></td><td>⊕</td><td></td><td></td></tr> </table>	⊕					AC100	TB1			-240V	TB3			40	TB5			41	TB7			42	TB9			P	TB11			44	TB13			46	TB15			NC	TB17			NC	TB19			NC	TB21			24V	TB23			⊕		
		⊕																																																												
			AC100	TB1																																																										
			-240V	TB3																																																										
			40	TB5																																																										
			41	TB7																																																										
			42	TB9																																																										
			P	TB11																																																										
			44	TB13																																																										
			46	TB15																																																										
			NC	TB17																																																										
			NC	TB19																																																										
			NC	TB21																																																										
	24V	TB23																																																												
	⊕																																																													
TB4	COM0	TB3	-240V																																																											
TB6	COM1	TB5	40																																																											
TB8	COM2	TB7	41																																																											
TB10	43	TB9	42																																																											
TB12	COM3	TB11	P																																																											
TB14	45	TB13	44																																																											
TB16	47	TB15	46																																																											
TB18	NC	TB17	NC																																																											
TB20	NC	TB19	NC																																																											
TB22	NC	TB21	NC																																																											
TB24	24G	TB23	24V																																																											

* XBC input : P00~P23, XEC input : I00~I35 * XBC output : P40~P57, XEC output : Q00~Q23

XBC/XEC-DP32H

Transistor output wiring
(source type)

Circuit configuration		No.	Contact	No.	Contact	Type
	TB05	TB05	TB05	TB05	AC100	TB1
	TB04	TB04	TB04	TB04	-240V	TB3
	TB07	TB07	TB07	TB07	Q00	TB5
	TB06	TB06	TB06	TB06	Q01	TB7
	TB09	TB09	TB09	TB09	Q02	TB9
	TB10	TB10	TB10	TB10	N	TB11
	TB12	TB12	TB12	TB12	Q04	TB13
	TB14	TB14	TB14	TB14	Q06	TB15
	TB16	TB16	TB16	TB16	NC	TB17
	TB18	TB18	TB18	TB18	NC	TB19
	TB20	TB20	TB20	TB20	NC	TB21
	TB22	TB22	TB22	TB22	24V	TB23
	TB24	TB24	TB24	TB24	24G	TB23

XBC/XEC-DR30SU

XBC/XEC-DN30SU

XBC/XEC-DP30SU

Input wiring
(sink/source type)

Circuit configuration		No.	Contact	No.	Contact	Type
	TB6	TB6	TB6	TB6	RX	TB1
	TB23	TB23	TB23	TB23	TX	TB3
	TB24	TB24	TB24	TB24	SG	TB5
	COM	COM	COM	COM	01	TB7
	TB6	TB6	TB6	TB6	03	TB9
	TB10	TB10	TB10	TB10	05	TB11
	TB12	TB12	TB12	TB12	07	TB13
	TB14	TB14	TB14	TB14	09	TB15
	TB16	TB16	TB16	TB16	0B	TB17
	TB18	TB18	TB18	TB18	0D	TB19
	TB20	TB20	TB20	TB20	0F	TB21
	TB22	TB22	TB22	TB22	11	TB23
	TB24	TB24	TB24	TB24	COM	TB23

XBC/XEC-DR30SU

Relay output wiring

Circuit configuration		No.	Contact	No.	Contact	Type
	TB5	TB5	TB5	TB5	AC100	TB1
	COM0	COM0	COM0	COM0	-240V	TB3
	TB4	TB4	TB4	TB4	40	TB5
	TB7	TB7	TB7	TB7	41	TB7
	TB6	TB6	TB6	TB6	42	TB9
	TB9	TB9	TB9	TB9	NC	TB11
	TB10	TB10	TB10	TB10	44	TB13
	TB12	TB12	TB12	TB12	46	TB15
	TB14	TB14	TB14	TB14	47	TB17
	TB16	TB16	TB16	TB16	48	TB19
	TB18	TB18	TB18	TB18	4A	TB21
	TB20	TB20	TB20	TB20	4B	TB23
	TB22	TB22	TB22	TB22	24V	TB23
	TB24	TB24	TB24	TB24	24G	TB23

* XBC input : P00~P23, XEC input : I00~I35 * XBC output : P40~P57, XEC output : Q00~Q23

XBC/XEC-DN30SU

Transistor output wiring
(sink type)

Circuit configuration		No.	Contact	No.	Contact	Type
	TB2	PE	TB1	AC100		TB1
	TB4	COM0	TB3	-240V		TB3
	TB6	COM1	TB5	40		TB5
	TB8	COM2	TB7	41		TB7
	TB10	43	TB9	42		TB9
	TB12	COM3	TB11	P		TB11
	TB14	45	TB13	44		TB13
	TB16	47	TB15	46		TB15
	TB18	COM4	TB17	NC		TB17
	TB20	49	TB19	48		TB19
	TB22	4B	TB21	4A		TB21
	TB24	24G	TB23	24V		TB23

XBC/XEC-DP30SU

Transistor output wiring
(source type)

Circuit configuration		No.	Contact	No.	Contact	Type
	TB2	PE	TB1	AC100		TB1
	TB4	COM0	TB3	-240V		TB3
	TB6	COM1	TB5	Q00		TB5
	TB8	COM2	TB7	Q01		TB7
	TB10	Q03	TB9	Q02		TB9
	TB12	COM3	TB11	N		TB11
	TB14	Q05	TB13	Q04		TB13
	TB16	Q07	TB15	Q06		TB15
	TB18	COM4	TB17	NC		TB17
	TB20	Q09	TB19	Q08		TB19
	TB22	Q11	TB21	Q10		TB21
	TB24	24G	TB23	24V		TB23

XBC/XEC-DR40SU

XBC/XEC-DN40SU

XBC/XEC-DP40SU

DC24 Input wiring
(sink/source type)

Circuit configuration		No.	Contact	No.	Contact	Type
	TB2	485+	TB1	RX		TB1
	TB4	485-	TB3	TX		TB3
	TB6	00	TB5	SG		TB5
	TB8	02	TB7	01		TB7
	TB10	04	TB9	03		TB9
	TB12	06	TB11	05		TB11
	TB14	08	TB13	07		TB13
	TB16	0A	TB15	09		TB15
	TB18	0C	TB17	0B		TB17
	TB20	0E	TB19	0D		TB19
	TB22	10	TB21	0F		TB21
	TB24	12	TB23	11		TB23
TB26	14	TB25	13	TB25		
TB28	16	TB27	15	TB27		
TB30	COM	TB29	17	TB29		

* XBC input : P00~P23, XEC input : I00~I35 * XBC output : P40~P57, XEC output : Q00~Q23

XBC/XEC-DR40SU Relay output wiring

Circuit configuration		No.	Contact	No.	Contact	Type	
	TB2	PE	TB1	AC100		TB1	
	TB4	COM0	TB3	-240V		TB3	
	TB6	COM1	TB5	40		TB5	
	TB8	COM2	TB7	41		TB7	
	TB10	43	TB9	42		TB9	
	TB12	COM3	TB11	NC		TB11	
	TB14	45	TB13	44		TB13	
	TB16	47	TB15	46		TB15	
	TB18	COM4	TB17	NC		TB17	
	TB20	49	TB19	48		TB19	
	TB22	4B	TB21	4A		TB21	
	TB24	COM5	TB23	NC		TB23	
	TB26	4D	TB25	4C		TB25	
	TB28	4F	TB27	4E		TB27	
	TB30	24G	TB29	24V		TB29	

XBC/XEC-DN40SU Transistor output wiring (sink type)

Circuit configuration		No.	Contact	No.	Contact	Type	
	TB2	PE	TB1	AC100		TB1	
	TB4	COM0	TB3	-240V		TB3	
	TB6	COM1	TB5	40		TB5	
	TB8	COM2	TB7	41		TB7	
	TB10	43	TB9	42		TB9	
	TB12	COM3	TB11	P		TB11	
	TB14	45	TB13	44		TB13	
	TB16	47	TB15	46		TB15	
	TB18	COM4	TB17	NC		TB17	
	TB20	49	TB19	48		TB19	
	TB22	4B	TB21	4A		TB21	
	TB24	COM5	TB23	NC		TB23	
	TB26	4D	TB25	4C		TB25	
	TB28	4F	TB27	4E		TB27	
	TB30	24G	TB29	24V		TB29	

XBC/XEC-DP40SU Transistor output wiring (source type)

Circuit configuration		No.	Contact	No.	Contact	Type	
	TB2	PE	TB1	AC100		TB1	
	TB4	COM0	TB3	-240V		TB3	
	TB6	COM1	TB5	00		TB5	
	TB8	COM2	TB7	01		TB7	
	TB10	03	TB9	02		TB9	
	TB12	COM3	TB11	N		TB11	
	TB14	05	TB13	04		TB13	
	TB16	07	TB15	06		TB15	
	TB18	COM4	TB17	NC		TB17	
	TB20	09	TB19	08		TB19	
	TB22	11	TB21	10		TB21	
	TB24	COM5	TB23	NC		TB23	
	TB26	13	TB25	12		TB25	
	TB28	15	TB27	14		TB27	
	TB30	24G	TB29	24V		TB29	

* XBC input : P00~P23, XEC input : I00~I35 * XBC output : P40~P57, XEC output : Q00~Q23

XBC/XEC-DR60SU
XBC/XEC-DN60SU
XBC/XEC-DP60SU
 Input wiring
 (sink/source type)

Circuit configuration		No.	Contact	No.	Contact	Type
		TB2	485+	TB1	RX	
		TB4	485-	TB3	TX	
		TB6	00	TB5	SG	
		TB8	02	TB7	01	
		TB10	04	TB9	03	
		TB12	06	TB11	05	
		TB14	08	TB13	07	
		TB16	0A	TB15	09	
		TB18	0C	TB17	0B	
		TB20	0E	TB19	0D	
		TB22	10	TB21	0F	
		TB24	12	TB23	11	
		TB26	14	TB25	13	
		TB28	16	TB27	15	
		TB30	18	TB29	17	
		TB32	1A	TB31	19	
		TB34	1C	TB33	1B	
		TB36	1E	TB35	1D	
		TB38	20	TB37	1F	
		TB40	22	TB39	21	
		TB42	COM	TB41	23	

Terminal block no.

TB2	485+	RX	TB1
TB4	485-	TX	TB3
TB6	00	SG	TB5
TB8	02	01	TB7
TB10	04	03	TB9
TB12	06	05	TB11
TB14	08	07	TB13
TB16	0A	09	TB15
TB18	0C	0B	TB17
TB20	0E	0D	TB19
TB22	10	0F	TB21
TB24	12	11	TB23
TB26	14	13	TB25
TB28	16	15	TB27
TB30	18	17	TB29
TB32	1A	19	TB31
TB34	1C	1B	TB33
TB36	1E	1D	TB35
TB38	20	1F	TB37
TB40	22	21	TB39
TB42	COM	23	TB41

XBC/XEC-DR60SU
 Relay output wiring

Circuit configuration		No.	Contact	No.	Contact	Type
		TB2	PE	TB1	AC100	
		TB4	COM0	TB3	-240V	
		TB6	COM1	TB5	40	
		TB8	COM2	TB7	41	
		TB10	43	TB9	42	
		TB12	COM3	TB11	NC	
		TB14	45	TB13	44	
		TB16	47	TB15	46	
		TB18	COM4	TB17	NC	
		TB20	49	TB19	48	
		TB22	4B	TB21	4A	
		TB24	COM5	TB23	NC	
		TB26	4D	TB25	4C	
		TB28	4F	TB27	4E	
		TB30	COM6	TB29	NC	
		TB32	51	TB31	50	
		TB34	53	TB33	52	
		TB36	COM7	TB35	NC	
		TB38	55	TB37	54	
		TB40	57	TB39	56	
		TB42	24G	TB41	24V	

Terminal block no.

TB2	485+	AC100	TB1
TB4	485-	-240V	TB3
TB6	00	40	TB5
TB8	02	41	TB7
TB10	04	42	TB9
TB12	06	NC	TB11
TB14	08	44	TB13
TB16	0A	46	TB15
TB18	0C	NC	TB17
TB20	0E	48	TB19
TB22	10	4A	TB21
TB24	12	NC	TB23
TB26	14	4C	TB25
TB28	16	4E	TB27
TB30	18	NC	TB29
TB32	1A	50	TB31
TB34	1C	52	TB33
TB36	1E	NC	TB35
TB38	20	54	TB37
TB40	22	56	TB39
TB42	COM	24V	TB41

* XBC input : P00~P23, XEC input : I00~I35 * XBC output : P40~P57, XEC output : Q00~Q23

XBC/XEC SU

XBC/XEC-DN60SU

Transistor output wiring
(sink type)

Circuit configuration		No.	Contact	No.	Contact	Type																																																																					
	TB2	PE	TB1	AC100	<table border="1"> <tr> <td>TB2</td> <td>AC100</td> <td>TB1</td> </tr> <tr> <td>TB4</td> <td>-240V</td> <td>TB3</td> </tr> <tr> <td>COM0</td> <td>40</td> <td>TB5</td> </tr> <tr> <td>COM1</td> <td>41</td> <td>TB7</td> </tr> <tr> <td>COM2</td> <td>42</td> <td>TB9</td> </tr> <tr> <td>43</td> <td>44</td> <td>TB11</td> </tr> <tr> <td>COM3</td> <td>P</td> <td>TB13</td> </tr> <tr> <td>45</td> <td>44</td> <td>TB15</td> </tr> <tr> <td>47</td> <td>46</td> <td>TB17</td> </tr> <tr> <td>COM4</td> <td>48</td> <td>TB19</td> </tr> <tr> <td>49</td> <td>4A</td> <td>TB21</td> </tr> <tr> <td>4B</td> <td>4A</td> <td>TB23</td> </tr> <tr> <td>COM5</td> <td>4C</td> <td>TB25</td> </tr> <tr> <td>4D</td> <td>4C</td> <td>TB27</td> </tr> <tr> <td>4E</td> <td>4E</td> <td>TB29</td> </tr> <tr> <td>COM6</td> <td>50</td> <td>TB31</td> </tr> <tr> <td>51</td> <td>50</td> <td>TB33</td> </tr> <tr> <td>53</td> <td>52</td> <td>TB35</td> </tr> <tr> <td>COM7</td> <td>54</td> <td>TB37</td> </tr> <tr> <td>55</td> <td>54</td> <td>TB39</td> </tr> <tr> <td>57</td> <td>56</td> <td>TB41</td> </tr> <tr> <td>24G</td> <td>24V</td> <td>TB42</td> </tr> </table>	TB2	AC100	TB1	TB4	-240V	TB3	COM0	40	TB5	COM1	41	TB7	COM2	42	TB9	43	44	TB11	COM3	P	TB13	45	44	TB15	47	46	TB17	COM4	48	TB19	49	4A	TB21	4B	4A	TB23	COM5	4C	TB25	4D	4C	TB27	4E	4E	TB29	COM6	50	TB31	51	50	TB33	53	52	TB35	COM7	54	TB37	55	54	TB39	57	56	TB41	24G	24V	TB42	TB4	COM0	TB3	-240V
	TB2	AC100	TB1																																																																								
	TB4	-240V	TB3																																																																								
	COM0	40	TB5																																																																								
	COM1	41	TB7																																																																								
	COM2	42	TB9																																																																								
	43	44	TB11																																																																								
	COM3	P	TB13																																																																								
	45	44	TB15																																																																								
	47	46	TB17																																																																								
	COM4	48	TB19																																																																								
	49	4A	TB21																																																																								
	4B	4A	TB23																																																																								
	COM5	4C	TB25																																																																								
	4D	4C	TB27																																																																								
	4E	4E	TB29																																																																								
	COM6	50	TB31																																																																								
	51	50	TB33																																																																								
	53	52	TB35																																																																								
	COM7	54	TB37																																																																								
	55	54	TB39																																																																								
	57	56	TB41																																																																								
	24G	24V	TB42																																																																								
	TB6	COM1	TB5	40																																																																							
TB8	COM2	TB7	41																																																																								
TB10	43	TB9	42																																																																								
TB12	COM3	TB11	P																																																																								
TB14	45	TB13	44																																																																								
TB16	47	TB15	46																																																																								
TB18	COM4	TB17	NC																																																																								
TB20	49	TB19	48																																																																								
TB22	4B	TB21	4A																																																																								
TB24	COM5	TB23	NC																																																																								
TB26	4D	TB25	4C																																																																								
TB28	4F	TB27	4E																																																																								
TB30	COM6	TB29	NC																																																																								
TB32	51	TB31	50																																																																								
TB34	53	TB33	52																																																																								
TB36	COM7	TB35	NC																																																																								
TB38	55	TB37	54																																																																								
TB40	57	TB39	56																																																																								
TB42	24G	TB41	24V																																																																								

XBC/XEC-DP60SU

Transistor output wiring
(source type)

Circuit configuration		No.	Contact	No.	Contact	Type																																																																					
	TB2	PE	TB1	AC100	<table border="1"> <tr> <td>TB2</td> <td>AC100</td> <td>TB1</td> </tr> <tr> <td>TB4</td> <td>-240V</td> <td>TB3</td> </tr> <tr> <td>COM0</td> <td>00</td> <td>TB5</td> </tr> <tr> <td>COM1</td> <td>01</td> <td>TB7</td> </tr> <tr> <td>COM2</td> <td>02</td> <td>TB9</td> </tr> <tr> <td>03</td> <td>N</td> <td>TB11</td> </tr> <tr> <td>COM3</td> <td>04</td> <td>TB13</td> </tr> <tr> <td>05</td> <td>04</td> <td>TB15</td> </tr> <tr> <td>07</td> <td>06</td> <td>TB17</td> </tr> <tr> <td>COM4</td> <td>08</td> <td>TB19</td> </tr> <tr> <td>09</td> <td>08</td> <td>TB21</td> </tr> <tr> <td>11</td> <td>10</td> <td>TB23</td> </tr> <tr> <td>COM5</td> <td>12</td> <td>TB25</td> </tr> <tr> <td>13</td> <td>12</td> <td>TB27</td> </tr> <tr> <td>15</td> <td>14</td> <td>TB29</td> </tr> <tr> <td>COM6</td> <td>16</td> <td>TB31</td> </tr> <tr> <td>17</td> <td>18</td> <td>TB33</td> </tr> <tr> <td>19</td> <td>18</td> <td>TB35</td> </tr> <tr> <td>COM7</td> <td>20</td> <td>TB37</td> </tr> <tr> <td>21</td> <td>20</td> <td>TB39</td> </tr> <tr> <td>23</td> <td>22</td> <td>TB41</td> </tr> <tr> <td>24G</td> <td>24V</td> <td>TB42</td> </tr> </table>	TB2	AC100	TB1	TB4	-240V	TB3	COM0	00	TB5	COM1	01	TB7	COM2	02	TB9	03	N	TB11	COM3	04	TB13	05	04	TB15	07	06	TB17	COM4	08	TB19	09	08	TB21	11	10	TB23	COM5	12	TB25	13	12	TB27	15	14	TB29	COM6	16	TB31	17	18	TB33	19	18	TB35	COM7	20	TB37	21	20	TB39	23	22	TB41	24G	24V	TB42	TB4	COM0	TB3	-240V
	TB2	AC100	TB1																																																																								
	TB4	-240V	TB3																																																																								
	COM0	00	TB5																																																																								
	COM1	01	TB7																																																																								
	COM2	02	TB9																																																																								
	03	N	TB11																																																																								
	COM3	04	TB13																																																																								
	05	04	TB15																																																																								
	07	06	TB17																																																																								
	COM4	08	TB19																																																																								
	09	08	TB21																																																																								
	11	10	TB23																																																																								
	COM5	12	TB25																																																																								
	13	12	TB27																																																																								
	15	14	TB29																																																																								
	COM6	16	TB31																																																																								
	17	18	TB33																																																																								
	19	18	TB35																																																																								
	COM7	20	TB37																																																																								
	21	20	TB39																																																																								
	23	22	TB41																																																																								
	24G	24V	TB42																																																																								
	TB6	COM1	TB5	00																																																																							
TB8	COM2	TB7	01																																																																								
TB10	03	TB9	02																																																																								
TB12	COM3	TB11	N																																																																								
TB14	05	TB13	04																																																																								
TB16	07	TB15	06																																																																								
TB18	COM4	TB17	NC																																																																								
TB20	09	TB19	08																																																																								
TB22	11	TB21	10																																																																								
TB24	COM5	TB23	NC																																																																								
TB26	13	TB25	12																																																																								
TB28	15	TB27	14																																																																								
TB30	COM6	TB29	NC																																																																								
TB32	17	TB31	16																																																																								
TB34	19	TB33	18																																																																								
TB36	COM7	TB35	NC																																																																								
TB38	21	TB37	20																																																																								
TB40	23	TB39	22																																																																								
TB42	24G	TB41	24V																																																																								

* XBC input : P00~P23, XEC input : I00~I35 * XBC output : P40~P57, XEC output : Q00~Q23



XBC/XEC SU



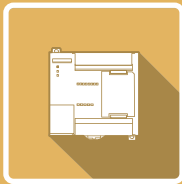

XBC/XEC E

Economic

C o n t e n t s

Performance specifications	42
Wiring	43



Economic

Performance specifications

Item	Specifications ('E' type)			
	XBC/XEC-DR10E XBC/XEC-DN10E XBC/XEC-DP10E	XBC/XEC-DR14E XBC/XEC-DN14E XBC/XEC-DP14E	XBC/XEC-DR20E XBC/XEC-DN20E XBC/XEC-DP20E	XBC/XEC-DR30E XBC/XEC-DN30E XBC/XEC-DP30E
Program control method	Reiterative operation, Fixed cycle operation			
I/O control method	Scan synchronized batch processing method (Refresh method) Direct method by instruction			
Program language	Ladder Diagram (LD), Sequential Function Chart (SFC) Structured Text (ST), Instruction List (IL)			
Processing speed (Basic instruction)	240 ns/step			
Program capacity	4 Kstep (XBC-D×××E), 50 KB (XEC-D×××E)			
Max. I/O points (Main+Option X)	14 point (1 option)	18 point (1 option)	28 point (2 option)	38 point (2 option)
Operation Mode	RUN, STOP, DEBUG			
Total number of program block	128			
Task	Initialization	1		
	Fixed period	8		
	External input	4 (%I×0.0.0~%I×0.0.3)		
	Internal device	8		
Program port	RS-232C 1 channel (Loader)			
Self - diagnostic functions	Watchdog Timer, Memory error detection I/O error detection, etc.			
Built-in functions	RS-232C or RS-485(1 ch), Pulse catch, Input filter, External interrupt, High-speed counter			
Retain data at power failure	Latch area setting at basic parameter			

Wiring | XBC/XEC E input/output wiring

XBC/XEC-DR10E
XBC/XEC-DN10E
XBC/XEC-DP10E
 Input iring
 (sink/source type)

Circuit configuration		No.	Contact	No.	Contact	Type																											
		TB2	485+	TB1	RX	<table border="1"> <tr> <td>⊕</td> <td>RX</td> <td>TB1</td> </tr> <tr> <td>⊖</td> <td>TX</td> <td>TB3</td> </tr> <tr> <td>485+</td> <td>TX</td> <td>TB3</td> </tr> <tr> <td>485-</td> <td>SG</td> <td>TB5</td> </tr> <tr> <td>00</td> <td>01</td> <td>TB7</td> </tr> <tr> <td>02</td> <td>03</td> <td>TB9</td> </tr> <tr> <td>04</td> <td>05</td> <td>TB11</td> </tr> <tr> <td>NC</td> <td>NC</td> <td>TB13</td> </tr> <tr> <td>COM</td> <td>⊕</td> <td>TB14</td> </tr> </table>	⊕	RX	TB1	⊖	TX	TB3	485+	TX	TB3	485-	SG	TB5	00	01	TB7	02	03	TB9	04	05	TB11	NC	NC	TB13	COM	⊕	TB14
		⊕	RX	TB1																													
		⊖	TX	TB3																													
		485+	TX	TB3																													
		485-	SG	TB5																													
		00	01	TB7																													
		02	03	TB9																													
		04	05	TB11																													
		NC	NC	TB13																													
		COM	⊕	TB14																													
		TB4	485-	TB3	TX																												
		TB6	00	TB5	SG																												
		TB8	02	TB7	01																												
		TB10	04	TB9	03																												
TB12	NC	TB11	05																														
TB14	COM	TB13	NC																														

XBC/XEC-DR10E
 Relay output wiring

Circuit configuration		No.	Contact	No.	Contact	Type																								
		TB2	PE	TB1	AC100	<table border="1"> <tr> <td>⊕</td> <td>AC100</td> <td>TB1</td> </tr> <tr> <td>⊖</td> <td>-240V</td> <td>TB3</td> </tr> <tr> <td>PE</td> <td>40</td> <td>TB5</td> </tr> <tr> <td>COM0</td> <td>41</td> <td>TB7</td> </tr> <tr> <td>COM1</td> <td>42</td> <td>TB9</td> </tr> <tr> <td>COM2</td> <td>43</td> <td>TB11</td> </tr> <tr> <td>NC</td> <td>24V</td> <td>TB13</td> </tr> <tr> <td>24G</td> <td>⊕</td> <td>TB14</td> </tr> </table>	⊕	AC100	TB1	⊖	-240V	TB3	PE	40	TB5	COM0	41	TB7	COM1	42	TB9	COM2	43	TB11	NC	24V	TB13	24G	⊕	TB14
		⊕	AC100	TB1																										
		⊖	-240V	TB3																										
		PE	40	TB5																										
		COM0	41	TB7																										
		COM1	42	TB9																										
		COM2	43	TB11																										
		NC	24V	TB13																										
		24G	⊕	TB14																										
		TB4	COM0	TB3	-240V																									
		TB6	COM1	TB5	40																									
		TB8	COM2	TB7	41																									
		TB10	43	TB9	42																									
		TB12	NC	TB11	NC																									
TB14	24G	TB13	24V																											

XBC/XEC-DN10E
 Transistor output wiring
 (sink type)

Circuit configuration		No.	Contact	No.	Contact	Type																								
		TB2	PE	TB1	AC100	<table border="1"> <tr> <td>⊕</td> <td>AC100</td> <td>TB1</td> </tr> <tr> <td>⊖</td> <td>-240V</td> <td>TB3</td> </tr> <tr> <td>PE</td> <td>00</td> <td>TB5</td> </tr> <tr> <td>P</td> <td>01</td> <td>TB7</td> </tr> <tr> <td>COM0</td> <td>02</td> <td>TB9</td> </tr> <tr> <td>COM1</td> <td>03</td> <td>TB11</td> </tr> <tr> <td>NC</td> <td>24V</td> <td>TB13</td> </tr> <tr> <td>24G</td> <td>⊕</td> <td>TB14</td> </tr> </table>	⊕	AC100	TB1	⊖	-240V	TB3	PE	00	TB5	P	01	TB7	COM0	02	TB9	COM1	03	TB11	NC	24V	TB13	24G	⊕	TB14
		⊕	AC100	TB1																										
		⊖	-240V	TB3																										
		PE	00	TB5																										
		P	01	TB7																										
		COM0	02	TB9																										
		COM1	03	TB11																										
		NC	24V	TB13																										
		24G	⊕	TB14																										
		TB4	P	TB3	-240V																									
		TB6	COM0	TB5	00																									
		TB8	COM1	TB7	01																									
		TB10	03	TB9	02																									
		TB12	NC	TB11	NC																									
TB14	24G	TB13	24V																											

XBC/XEC-DP10E
 Transistor output wiring
 (source type)

Circuit configuration		No.	Contact	No.	Contact	Type																								
		TB2	PE	TB1	AC100	<table border="1"> <tr> <td>⊕</td> <td>AC100</td> <td>TB1</td> </tr> <tr> <td>⊖</td> <td>-240V</td> <td>TB3</td> </tr> <tr> <td>PE</td> <td>00</td> <td>TB5</td> </tr> <tr> <td>N</td> <td>01</td> <td>TB7</td> </tr> <tr> <td>COM0</td> <td>02</td> <td>TB9</td> </tr> <tr> <td>COM1</td> <td>03</td> <td>TB11</td> </tr> <tr> <td>NC</td> <td>24V</td> <td>TB13</td> </tr> <tr> <td>24G</td> <td>⊕</td> <td>TB14</td> </tr> </table>	⊕	AC100	TB1	⊖	-240V	TB3	PE	00	TB5	N	01	TB7	COM0	02	TB9	COM1	03	TB11	NC	24V	TB13	24G	⊕	TB14
		⊕	AC100	TB1																										
		⊖	-240V	TB3																										
		PE	00	TB5																										
		N	01	TB7																										
		COM0	02	TB9																										
		COM1	03	TB11																										
		NC	24V	TB13																										
		24G	⊕	TB14																										
		TB4	N	TB3	~240V																									
		TB6	COM0	TB5	00																									
		TB8	COM1	TB7	01																									
		TB10	03	TB9	02																									
		TB12	NC	TB11	NC																									
TB14	24G	TB13	24V																											

* XBC input : P00~P11, XEC input : I00~I17 * XBC output : P40~P4B, XEC output : Q00~Q11



XBC/XEC-DR14E
XBC/XEC-DN14E
XBC/XEC-DP14E
 Input wiring
 (sink/source type)

Circuit configuration		No.	Contact	No.	Contact	Type																											
		TB2	485+	TB1	RX	<table border="1"> <tr><td>+</td><td>RX</td><td>TB1</td></tr> <tr><td>485+</td><td>TX</td><td>TB3</td></tr> <tr><td>485-</td><td>SG</td><td>TB5</td></tr> <tr><td>00</td><td>01</td><td>TB7</td></tr> <tr><td>02</td><td>03</td><td>TB9</td></tr> <tr><td>04</td><td>05</td><td>TB11</td></tr> <tr><td>06</td><td>07</td><td>TB13</td></tr> <tr><td>COM</td><td></td><td></td></tr> <tr><td></td><td>+</td><td></td></tr> </table>	+	RX	TB1	485+	TX	TB3	485-	SG	TB5	00	01	TB7	02	03	TB9	04	05	TB11	06	07	TB13	COM				+	
		+	RX	TB1																													
		485+	TX	TB3																													
		485-	SG	TB5																													
		00	01	TB7																													
		02	03	TB9																													
		04	05	TB11																													
		06	07	TB13																													
		COM																															
			+																														
		TB4	485-	TB3	TX																												
		TB6	00	TB5	SG																												
		TB8	02	TB7	01																												
		TB10	04	TB9	03																												
TB12	06	TB11	05																														
TB14	COM	TB13	07																														

XBC-DR14E
 Relay output wiring

Circuit configuration		No.	Contact	No.	Contact	Type																														
		TB2	PE	TB1	AC100	<table border="1"> <tr><td>+</td><td></td><td>TB1</td></tr> <tr><td>PE</td><td>AC100</td><td>TB1</td></tr> <tr><td></td><td>-240V</td><td>TB3</td></tr> <tr><td>COM0</td><td>40</td><td>TB5</td></tr> <tr><td>COM1</td><td>41</td><td>TB7</td></tr> <tr><td>COM2</td><td>42</td><td>TB9</td></tr> <tr><td>43</td><td>44</td><td>TB11</td></tr> <tr><td>45</td><td>24V</td><td>TB13</td></tr> <tr><td>24G</td><td></td><td></td></tr> <tr><td></td><td>+</td><td></td></tr> </table>	+		TB1	PE	AC100	TB1		-240V	TB3	COM0	40	TB5	COM1	41	TB7	COM2	42	TB9	43	44	TB11	45	24V	TB13	24G				+	
		+		TB1																																
		PE	AC100	TB1																																
			-240V	TB3																																
		COM0	40	TB5																																
		COM1	41	TB7																																
		COM2	42	TB9																																
		43	44	TB11																																
		45	24V	TB13																																
		24G																																		
	+																																			
TB4	COM0	TB3	-240V																																	
TB6	COM1	TB5	40																																	
TB8	COM2	TB7	41																																	
TB10	43	TB9	42																																	
TB12	NC	TB11	NC																																	
TB14	24G	TB13	24V																																	

XBC/XEC-DN14E
 Transistor output wiring
 (sink type)

Circuit configuration		No.	Contact	No.	Contact	Type																														
		TB2	PE	TB1	AC100	<table border="1"> <tr><td>+</td><td></td><td>TB1</td></tr> <tr><td>PE</td><td>AC100</td><td>TB1</td></tr> <tr><td></td><td>-240V</td><td>TB3</td></tr> <tr><td>P</td><td>00</td><td>TB5</td></tr> <tr><td>COM0</td><td>01</td><td>TB7</td></tr> <tr><td>COM1</td><td>02</td><td>TB9</td></tr> <tr><td>03</td><td>04</td><td>TB11</td></tr> <tr><td>05</td><td>24V</td><td>TB13</td></tr> <tr><td>24G</td><td></td><td></td></tr> <tr><td></td><td>+</td><td></td></tr> </table>	+		TB1	PE	AC100	TB1		-240V	TB3	P	00	TB5	COM0	01	TB7	COM1	02	TB9	03	04	TB11	05	24V	TB13	24G				+	
		+		TB1																																
		PE	AC100	TB1																																
			-240V	TB3																																
		P	00	TB5																																
		COM0	01	TB7																																
		COM1	02	TB9																																
		03	04	TB11																																
		05	24V	TB13																																
		24G																																		
			+																																	
		TB4	P	TB3	-240V																															
		TB6	COM0	TB5	00																															
		TB8	COM1	TB7	01																															
TB10	03	TB9	02																																	
TB12	05	TB11	04																																	
TB14	24G	TB13	24V																																	

XBC/XEC-DP14E
 Transistor output wiring
 (source type)

Circuit configuration		No.	Contact	No.	Contact	Type																														
		TB2	PE	TB1	AC100	<table border="1"> <tr><td>+</td><td></td><td>TB1</td></tr> <tr><td>PE</td><td>AC100</td><td>TB1</td></tr> <tr><td></td><td>-240V</td><td>TB3</td></tr> <tr><td>N</td><td>00</td><td>TB5</td></tr> <tr><td>COM0</td><td>01</td><td>TB7</td></tr> <tr><td>COM1</td><td>02</td><td>TB9</td></tr> <tr><td>03</td><td>04</td><td>TB11</td></tr> <tr><td>05</td><td>24V</td><td>TB13</td></tr> <tr><td>24G</td><td></td><td></td></tr> <tr><td></td><td>+</td><td></td></tr> </table>	+		TB1	PE	AC100	TB1		-240V	TB3	N	00	TB5	COM0	01	TB7	COM1	02	TB9	03	04	TB11	05	24V	TB13	24G				+	
		+		TB1																																
		PE	AC100	TB1																																
			-240V	TB3																																
		N	00	TB5																																
		COM0	01	TB7																																
		COM1	02	TB9																																
		03	04	TB11																																
		05	24V	TB13																																
		24G																																		
			+																																	
		TB4	N	TB3	-240V																															
		TB6	COM0	TB5	00																															
		TB8	COM1	TB7	01																															
TB10	03	TB9	02																																	
TB12	05	TB11	04																																	
TB14	24G	TB13	24V																																	

* XBC input : P00~P11, XEC input : I00~I17 * XBC output : P40~P4B, XEC output : Q00~Q11

XBC/XEC-DR20E
XBC/XEC-DN20E
XBC/XEC-DP20E
 Input iring
 (sink/source type)

Circuit configuration		No.	Contact	No.	Contact	Type
		TB1		TB1	RX	
		TB2	485+	TB2	TX	
		TB3	485-	TB3	SG	
		TB4	00	TB4	01	
		TB5	02	TB5	03	
		TB6	04	TB6	05	
		TB7	06	TB7	07	
		TB8	08	TB8	09	
		TB9	0A	TB9	0B	
		TB10	NC	TB10	NC	
		TB11	NC	TB11	NC	
		TB12	NC	TB12	NC	
		TB13	NC	TB13	NC	
TB14	NC	TB14	NC			
TB15	NC	TB15	NC			
TB16	NC	TB16	NC			
TB17	NC	TB17	NC			
TB18	NC	TB18	NC			
TB19	NC	TB19	NC			
TB20	NC	TB20	NC			
TB21	NC	TB21	NC			
TB22	NC	TB22	NC			
TB23	NC	TB23	NC			
TB24	COM	TB24	COM			

XBC-DR20E
 Relay output wiring

Circuit configuration		No.	Contact	No.	Contact	Type
		TB1	AC100	TB1	AC100	
		TB2	PE	TB2	-240V	
		TB3	COM0	TB3	40	
		TB4	COM1	TB4	41	
		TB5	COM2	TB5	42	
		TB6	COM3	TB6	44	
		TB7	NC	TB7	NC	
		TB8	NC	TB8	NC	
		TB9	NC	TB9	NC	
		TB10	NC	TB10	NC	
		TB11	NC	TB11	NC	
		TB12	NC	TB12	NC	
		TB13	NC	TB13	NC	
TB14	NC	TB14	NC			
TB15	NC	TB15	NC			
TB16	NC	TB16	NC			
TB17	NC	TB17	NC			
TB18	NC	TB18	NC			
TB19	NC	TB19	NC			
TB20	NC	TB20	NC			
TB21	NC	TB21	NC			
TB22	NC	TB22	NC			
TB23	24V	TB23	24V			
TB24	24G	TB24	24G			

XBC/XEC-DN20E
 Transistor output wiring
 (sink type)

Circuit configuration		No.	Contact	No.	Contact	Type
		TB1	AC100	TB1	AC100	
		TB2	PE	TB2	-240V	
		TB3	P	TB3	00	
		TB4	COM0	TB4	01	
		TB5	COM1	TB5	02	
		TB6	COM2	TB6	03	
		TB7	COM3	TB7	04	
		TB8	NC	TB8	NC	
		TB9	NC	TB9	NC	
		TB10	NC	TB10	NC	
		TB11	NC	TB11	NC	
		TB12	NC	TB12	NC	
		TB13	NC	TB13	NC	
TB14	NC	TB14	NC			
TB15	NC	TB15	NC			
TB16	NC	TB16	NC			
TB17	NC	TB17	NC			
TB18	NC	TB18	NC			
TB19	NC	TB19	NC			
TB20	NC	TB20	NC			
TB21	NC	TB21	NC			
TB22	NC	TB22	NC			
TB23	24V	TB23	24V			
TB24	24G	TB24	24G			

XBC/XEC-DP20E
 Transistor output wiring
 (source type)

Circuit configuration		No.	Contact	No.	Contact	Type
		TB1	AC100	TB1	AC100	
		TB2	PE	TB2	-240V	
		TB3	N	TB3	00	
		TB4	COM0	TB4	01	
		TB5	COM1	TB5	02	
		TB6	COM2	TB6	03	
		TB7	COM3	TB7	04	
		TB8	NC	TB8	NC	
		TB9	NC	TB9	NC	
		TB10	NC	TB10	NC	
		TB11	NC	TB11	NC	
		TB12	NC	TB12	NC	
		TB13	NC	TB13	NC	
TB14	NC	TB14	NC			
TB15	NC	TB15	NC			
TB16	NC	TB16	NC			
TB17	NC	TB17	NC			
TB18	NC	TB18	NC			
TB19	NC	TB19	NC			
TB20	NC	TB20	NC			
TB21	NC	TB21	NC			
TB22	NC	TB22	NC			
TB23	24V	TB23	24V			
TB24	24G	TB24	24G			

* XBC input : P00~P11, XEC input : I00~I17 * XBC output : P40~P4B, XEC output : Q00~Q11



XBC/XEC-DR30E
XBC/XEC-DN30E
XBC/XEC-DP30E
 Input wiring
 (sink/source type)

Circuit configuration		No.	Contact	No.	Contact	Type
		TB2	485+	TB1	RX	
		TB4	485-	TB3	TX	
		TB6	00	TB5	SG	
		TB8	02	TB7	01	
		TB10	04	TB9	03	
		TB12	06	TB11	05	
		TB14	08	TB13	07	
		TB16	0A	TB15	09	
		TB18	0C	TB17	0B	
		TB20	0E	TB19	0D	
		TB22	10	TB21	0F	
		TB24	COM	TB23	11	

XBC-DR30E
 Relay output wiring

Circuit configuration		No.	Contact	No.	Contact	Type
		TB2	PE	TB1	AC100	
		TB4	COM0	TB3	-240V	
		TB6	COM1	TB5	40	
		TB8	COM2	TB7	41	
		TB10	43	TB9	42	
		TB12	COM3	TB11	NC	
		TB14	45	TB13	44	
		TB16	47	TB15	46	
		TB18	COM4	TB17	NC	
		TB20	49	TB19	48	
		TB22	4B	TB21	4A	
		TB24	24G	TB23	24V	

XBC/XEC-DN30E
 Transistor output wiring
 (sink type)

Circuit configuration		No.	Contact	No.	Contact	Type
		TB2	PE	TB1	AC100	
		TB4	P	TB3	-240V	
		TB6	COM0	TB5	00	
		TB8	COM1	TB7	01	
		TB10	03	TB9	02	
		TB12	COM2	TB11	NC	
		TB14	05	TB13	04	
		TB16	07	TB15	06	
		TB18	COM3	TB17	NC	
		TB20	09	TB19	08	
		TB22	11	TB21	10	
		TB24	24G	TB23	24V	

XBC/XEC-DP30E
 Transistor output wiring
 (source type)

Circuit configuration		No.	Contact	No.	Contact	Type
		TB2	PE	TB1	AC100	
		TB4	N	TB3	-240V	
		TB6	COM0	TB5	00	
		TB8	COM1	TB7	01	
		TB10	03	TB9	02	
		TB12	COM2	TB11	NC	
		TB14	05	TB13	04	
		TB16	07	TB15	06	
		TB18	COM3	TB17	NC	
		TB20	09	TB19	08	
		TB22	11	TB21	10	
		TB24	24G	TB23	24V	

* XBC input : P00~P11, XEC input : I00~I17 * XBC output : P40~P4B, XEC output : Q00~Q11



XBC/KEC E

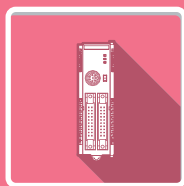

XBM Slim

Slim

C o n t e n t s

General specification	50
Performance specifications	51
Wiring	55





Slim

Modular type unit

(XBM-DN32H, DN32HP, DN32S, DR16S, DN16S)



Item	Descriptions			Standard
Ambient temperature	0 ~ 55 ° C			
Storage temperature	-25 ~ +70 ° C			
Ambient humidity	5 ~ 95%RH (Non-condensing)			
Storage humidity	5 ~ 95%RH (Non-condensing)			
Vibration resistance	Occasional vibration			10 times each direction (X, Y and Z) IEC61131-2
	Frequency	Acceleration	Pulse width	
	10 ≤ f < 57Hz	-	0.075mm	
	57 ≤ f ≤ 150Hz	9.8m/s ² (1G)	-	
	Continuous vibration			
	Frequency	Acceleration	Pulse width	
10 ≤ f < 57Hz	-	0.035mm		
57 ≤ f ≤ 150Hz	4.9m/s ² (0.5G)	-		
Shock resistance	<ul style="list-style-type: none"> • Peak acceleration: 147m/s² (15g) • Duration: 11ms • Pulse waveform: Half-sine, 3times each direction per each axis 			IEC61131-2
Noise resistance	Square wave impulse noise	±500 V		LS ELECTRIC Standard
	Electrostatic discharge	4kV		IEC61131-2 IEC61000-4-2
	Radiated electromagnetic field noise	80 ~ 1000MHz, 10V/m		IEC61131-2 IEC61000-4-3
	Fast transient/Burst noise	Main unit	Expansion module	
2kV		1kV		
Operating ambience	Free from corrosive gases and excessive dust			
Altitude	Up to 2,000m			
Pollution level ^{*1)}	Less than 2			
Cooling	Air-cooling			

^{*1)} Pollution level indicates the degree to which conductive material is generated in the environment where the equipment is used. Pollution level 2 is the condition that only non-conductive pollution occurred but temporary conductivity may be produced due to condensing.

Performance specifications

Common performance specifications for CPU



Item	Specifications		Remark
	XBM-DN32H2/XBM-DN32HP, XBM-DP32H2/XBM-DP32HP XBM-DN16H2/XBM-DP16H2/XBM-DR14H2		
Program control metho	Cyclic execution of stored program, Time-driven interrupt, Process-driven interrupt		
I/O control method	Batch processing by simultaneous scan (Refresh method), Directed by program instruction		
Program language	LD(Ladder Diagram), Instruction List, SFC (Sequential Function Chart)ST (Structured Text)		
Number of instructions	Basic	28	
	Application	677	
Processing speed (Basic instruction)	40ns/step		
Program capacity	64kStep		
Max. I/O points	256 points (Main + Expansion 7 stages)		
Data area	P	P0000 ~ P2047F (32,768 points)	Input/Ouput
	M	M0000 ~ M2047F (32,768 points)	
	K	K0000 ~ K4095F (65,536 points)	
	L	L0000 ~ L4095F (65,536 points)	Link
	F	F0000 ~ F2047F (32,768 points)	
	T	100ms, 10ms, 1ms: T0000 ~ T2047 (set by parameter)	Timer
	C	C0000 ~ C2047	Counter
	S	S00.00 ~ S127.99	Step
	D	D0000 ~ D32767	Data register
	U	U0.0 ~ U08.31	Analog Data
	Z	Z000 ~ Z127 (128word)	
	N	N0000 ~ N10239 (10,240 word)	
File resister	P	RAM area 8block (R00000 ~ R32,767)	
Total program	256		
Initial task	Initial task	1	
	Cyclic task	Max 16	
	I/O task	Max 8	
	Internal device task	Max 16	
	High Speed Counter task	Max 4	
	File resister	1	
Operation mode	RUN, STOP, DEBUG		
Self-diagnosis function	Detects errors of scan time, memory, I/O and power supply		
Program port	USB 1 channel		
Back-up method	Latch area setting in basic parameter		
Internal consumption current	540mA(XBM-DN/DP32H2(HP)), 460mA(XBM-DR14H2), 345mA(XBM-DN16H2), 345mA(XBM-DP16H2)		
Weight	134g		

XGB General specification

Common performance specifications for CPU



Item		Specifications		Remark	
		XEM-DN32H2/XEM-DN32HP, XEM-DP32H2/XEM-DP32HP XEM-DN16H2/XEM-DP16H2/XEM-DR14H2			
Program control metho		Cyclic execution of stored program, Time-driven interrupt, Process-driven interrupt			
I/O control method		Batch processing by simultaneous scan (Refresh method), Directed by program instruction			
Program language		LD (Ladder Diagram), Instruction List, SFC (Sequential Function Chart) ST(Structured Text)			
Number of instructions	Operator	18			
	Basic function	136+Real number operation function			
	Basic function block	43			
	Dedicated function block	Special function dedicated function			
Processing speed (Basic instruction)		40ns/step			
Program capacity		384KB			
Max. I/O points		256 points (Main + Expansion 7 stages)			
Data area	Automatic variable (A)	64KB (All area retain setting available)			
	Input variable (I)	2 KB (%IX15.15.63)			
	Output variable (Q)	2 KB (%QX15.15.63)			
	Direct variable	M	32KB (All area retain setting available)		
		R	32KB (2block)		
		W	64KB		
	Flag variable	F	4KB		
		K	8KB		
		L	8KB		
		U	576KB		
		N0000 ~ N10239 (10,240 word)			
Total program		256			
Initial task	Initial task	1			
	Cyclic task	Max 16			
	I/O task	Max 8			
	Internal device task	Max 16			
	High speed counter task	Max 4			
	Positioning task	1			
Operation mode		RUN, STOP, DEBUG			
Self-diagnosis function		Detects errors of scan time, memory, I/O and power supply			
Program port		USB 1 channel			
Back-up method		Latch area setting in basic parameter			
Internal consumption current		540mA			
Weight		134g			

Built in Function

Item		
PID control		Control by instruction, auto-tuning, PWM output, Forced output, Operation scan time setting, Antiwindup, Delta MV, SV lamp, Hybrid operation, Cascade operation
Cnet	PID control	Dedicated protocol(XGT) Modbus protocol User defined protocol , LS bus(inverter protocol)
	Channel	RS-232C 1 port and RS-485 1 port
Enet	Transfer spec	Cable: 100Base-TX, Speed: 100Mbps, Auto-MDIX*1, IEEE 802.3
	Topology	Star
	Diagnosis	Module information, Service condition
	Protocol	XGT dedicated, Modbus TCP/IP, user define frame
	Service	P2P, High Speed link, Remote connection, SMTP, SNTP, Auto scan
High speed counter	Performance	1 phase: 200β(2 phase: 100β')
	channels	1phase 4 channels, 2 phase 2 channels
	Counter mode	4 counter modes are supported based on input pulse and INC/DEC method <ul style="list-style-type: none"> • 1 pulse operation Mode : INC/DEC count by program • 1 pulse operation Mode : INC/DEC count by phase B pulse input • 2 pulse operation Mode : INC/DEC count by input pulse • 2 pulse operation Mode : INC/DEC count by difference of phase
	Function	<ul style="list-style-type: none"> • Internal/external preset • Latch counter • Compare output • No. of rotation per unit time
Position	Basic function	No. of control axis: 6axis(XBM / XEM-DN32H2: 2 axis) Control method : Position control, Speed control, Speed/Position control, Position/Speed control Control Unit: Pulse, mm, inch, degree Position data: 400 steps for each axis(1~400) Operation mode: end, keep, continuous Operation method: single, repeat
	Interpolation function	<ul style="list-style-type: none"> • 2/3/4/5/6 axis linear interpolation (XBM/XEM-DN32H2: 2 axis linear interpolation) • 2 axis circular interpolation • 3 axis helical interpolation(not supported in XBM / XEM-DN32H2)
	Position	Absolute method / Incremental method Position address range: -2,147,483,648 ~ 2,147,483,647(Pulse) Speed: max. 200kpps Acc/dec processing: Trapezoid-shaped , S-curve
	Origin return method	DOG + HOME (Off), DOG + HOME(On), Upper / Lower limit + HOME, DOG, High speed, / Lower limit, HOME
	Jog operation	Jog Operation, MPG Operation, Inching Operation
Pulse catch		10μs 4point (%IX0.0.0~%IX0.0.3), 50μs 4point (%IX0.0.4~%IX0.0.7)
External point Interrupt		10μs 4point (%IX0.0.0~%IX0.0.3), 50μs 4point (%IX0.0.4~%IX0.0.7)
Input filter		1,3,5,10,20,70,100ms

*1 Auto-MDIX(Automatic medium-dependent interface crossover) :
It is the function to automatically detect whether the cable connected to the Ethernet port is peer-to-peer(straight) or cross cable

XGB General specification

Common performance specifications for CPU



Item		Specifications	Remark
		XBM-DN32H	
Program control metho		Cyclic execution of stored program, Time-driven interrupt, Process-driven interrupt	
I/O control method		Batch processing by simultaneous scan (Refresh method), Directed by program instruction	
Program language		LD(Ladder Diagram), Instruction List, SFC (Sequential Function Chart)ST (Structured Text)	
Number of instructions	Basic	28	
	Application	677	
Processing speed (Basic instruction)		40ns/step	
Program capacity		64kStep	
Max. I/O points		256 points (Main + Expansion 7 stages)	
Data area	P	P0000 ~ P2047F (32,768 points)	Input/Ouput
	M	M0000 ~ M2047F (32,768 points)	
	K	K0000 ~ K4095F (65,536 points)	
	L	L0000 ~ L4095F (65,536 points)	Link
	F	F0000 ~ F2047F (32,768 points)	
	T	100 ^{ms} , 10 ^{ms} , 1 ^{ms} : T0000 ~ T2047 (set by parameter)	Timer
	C	C0000 ~ C2047	Counter
	S	S00.00 ~ S127.99	Step
	D	D0000 ~ D32767	Data register
	U	U0.0 ~ U08.31	Analog Data
	Z	Z000 ~ Z127 (128word)	
N	N0000 ~ N10239 (10,240 word)		
File resister	P	RAM area 8block (R00000 ~ R32,767)	
Total program		256	
Initial task	Initial task	1	
	Cyclic task	Max 16	
	I/O task	Max 8	
	Internal device task	Max 16	
	High Speed Counter task	Max 4	
	File resister	1	
Operation mode		RUN, STOP, DEBUG	
Self-diagnosis function		Detects errors of scan time, memory, I/O and power supply	
Program port		USB 1 channel	
Back-up method		Latch area setting in basic parameter	
Internal consumption current		540mA	
Weight		134g	

Modular type unit

Slim

Performance specifications

Item	XBM-DR16S	XBM-DN16S	XBM-DN32S
Control method	Repetitive, cyclic, fixed cycle operation, constant scan		
I/O control method	Refresh mode (Batch processing by scan synchronization), Direct mode by instruction		
Programming language	Ladder diagram, Instruction List		
Processing speed	160 ns/Step		
Program capacity	10Kstep		
Main unit I/O points	16 points (Input:8, Output:8)	16 points (Input:8, Output:8)	32 points (Input:16, Output:16)
Max. I/O points (Main + Expansion 7 stages)	240 points		256 points
Total program	128		
Operation mode	RUN, STOP, DEBUG		
Self diagnosis	Detects errors of scan time, memory error, I/O error, battery error, power error, etc.		
Program port	RS-232C 1 channel (Loader)		
Retain data at power failure	Latch area setting at basic parameter		
Built-in functions	RS-232C/RS-485(2 ch), Pulse catch, Input filter, External interrupt, PID control, High-speed counter, Positioning ^{*1)}		
Data memory			
XBM			
Data area	P	P0000 ~ P127F (2,048 points)	
	M	M0000 ~ M255F (4,096 points)	
	K	K0000 ~ K2559F (Special area: K2600~K2559F) (40,960 points)	
	L	L0000 ~ L1279F (20,480 points)	
	F	F000 ~ F255F (4,096 points)	
	T	100ms, 10ms, 1ms: T000 ~ T255 (256) (Adjustable by parameter setting)	
	C	C000 ~ C255 (256)	
	S	S00.00 ~ S127.99	
	D	D0000 ~ D5119 (5,120 word)	
	U	U00.00 ~ U07.31 (Analog data refresh area: 256 word)	
	Z	Z000 ~ Z127 (128 word)	
N	N0000 ~ N3935 (3,936 word)		

*1) XBM-DR16S does not have built-in positioning function.

XBM-DN32HP

16 point DC24V input wiring
(Source/Sink type)

Circuit configuration		No.	Contact	No.	Contact	Type
	B20	00	A20	20		
	B19	01	A19	21		
	B18	02	A18	22		
	B17	03	A17	23		
	B16	04	A16	24		
	B15	05	A15	25		
	B14	06	A14	26		
	B13	07	A13	27		
	B12	08	A12	28		
	B11	09	A11	29		
	B10	0A	A10	2A		
	B09	0B	A9	2B		
	B08	0C	A8	2C		
	B07	0D	A7	2D		
	B06	0E	A6	2E		
	B05	0F	A5	2F		
	B04	NC	A4	P		
B03	NC	A3	P			
B02	IN_COM	A2	OUT_COM			
B01	IN_COM	A1	OUT_COM			

XBM-DN32HP

16 point transistor output
(Sink type)

Circuit configuration		No.	Contact	Type	
	B20	00	A20	20	
	B19	01	A19	21	
	B18	02	A18	22	
	B17	03	A17	23	
	B16	04	A16	24	
	B15	05	A15	25	
	B14	06	A14	26	
	B13	07	A13	27	
	B12	08	A12	28	
	B11	09	A11	29	
	B10	0A	A10	2A	
	B09	0B	A9	2B	
	B08	0C	A8	2C	
	B07	0D	A7	2D	
	B06	0E	A6	2E	
	B05	0F	A5	2F	
	B04	NC	A4	P	
B03	NC	A3	P		
B02	IN_COM	A2	OUT_COM		
B01	IN_COM	A1	OUT_COM		

XBM-DN32H

Input wiring
(Sink / Source type)

Circuit configuration		No.	Contact	No.	Contact	Type
	B20	00	A20	20		
	B19	01	A19	21		
	B18	02	A18	22		
	B17	03	A17	23		
	B16	04	A16	24		
	B15	05	A15	25		
	B14	06	A14	26		
	B13	07	A13	27		
	B12	08	A12	28		
	B11	09	A11	29		
	B10	0A	A10	2A		
	B09	0B	A9	2B		
	B08	0C	A8	2C		
	B07	0D	A7	2D		
	B06	0E	A6	2E		
	B05	0F	A5	2F		
	B04	NC	A4	P		
	B03	NC	A3	P		
	B02	IN_COM	A2	OUT_COM		
	B01	IN_COM	A1	OUT_COM		

XBM-DN32H

Transistor output
(Sink type)

Circuit configuration		No.	Contact	Type
	B20	00	A20	20
	B19	01	A19	21
	B18	02	A18	22
	B17	03	A17	23
	B16	04	A16	24
	B15	05	A15	25
	B14	06	A14	26
	B13	07	A13	27
	B12	08	A12	28
	B11	09	A11	29
	B10	0A	A10	2A
	B09	0B	A9	2B
	B08	0C	A8	2C
	B07	0D	A7	2D
	B06	0E	A6	2E
	B05	0F	A5	2F
	B04	NC	A4	P
	B03	NC	A3	P
	B02	IN_COM	A2	OUT_COM
	B01	IN_COM	A1	OUT_COM

XBM Slim

XBM-DR16S

Input wiring
(sink/source type)

Circuit configuration		No.	Contact	Type
		TB1	0	
		TB2	1	
		TB3	2	
		TB4	3	
		TB5	4	
		TB6	5	
		TB7	6	
		TB8	7	
		TB9	COM	

XBM-DR16S

Relay output wiring

Circuit configuration		No.	Contact	Type
		TB1	20	
		TB2	21	
		TB3	22	
		TB4	23	
		TB5	24	
		TB6	25	
		TB7	26	
		TB8	27	
		TB9	COM	

XBM-DN16S

Input wiring(sink/source type)

Circuit configuration		No.	Contact	No.	Contact	Type
		B10	0	A10	NC	
		B09	1	A09	NC	
		B08	2	A08	NC	
		B07	3	A07	NC	
		B06	4	A06	NC	
		B05	5	A05	NC	
		B04	6	A04	NC	
		B03	7	A03	NC	
		B02	COM	A02	NC	
		B01	COM	A01	NC	

XBM-DR16S

Transistor output wiring
(sink type)

Circuit configuration		No.	Contact	Type
	B10	20		A10
	B09	21		A09
	B08	22		A08
	B07	23		A07
	B06	24		A06
	B05	25		A05
	B04	26		A04
	B03	27		A03
	B02	DC12 /24V		A02
	A10	NC		A01
	A09	NC		
	A08	NC		
	A07	NC		
	A06	NC		
	A05	NC		
	A04	NC		
A03	NC			
A02	COM			
A01	COM			

XBM-DN16S

Input wiring(sink/source type)

Circuit configuration		No.	Contact	No.	Contact	Type
	B10	0	A10	NC		A10
	B09	1	A09	NC		A09
	B08	2	A08	NC		A08
	B07	3	A07	NC		A07
	B06	4	A06	NC		A06
	B05	5	A05	NC		A05
	B04	6	A04	NC		A04
	B03	7	A03	NC		A03
	B02	COM	A02	COM		A02
	B01	COM	A01	COM		A01

XBM-DR16S

Transistor output wiring
(sink type)

Circuit configuration		No.	Contact	Type
	B10	20		A10
	B09	21		A09
	B08	22		A08
	B07	23		A07
	B06	24		A06
	B05	25		A05
	B04	26		A04
	B03	27		A03
	B02	DC12 /24V		A02
	A10	28		A01
	A09	29		
	A08	2A		
	A07	2B		
	A06	2C		
	A05	2D		
	A04	2E		
A03	2F			
A02	COM			
A01	COM			

XBM Slim

Slim

Transistor output wiring (XBM-DN16S)

Circuit configuration		No.	Contact	Type
	B10	20		
	B09	21		
	B08	22		
	B07	23		
	B06	24		
	B05	25		
	B04	26		
	B03	27		
	B02	DC12/24V		
	B01	24V		
	A10	NC		
	A09	NC		
	A08	NC		
	A07	NC		
	A06	NC		
	A05	NC		
A04	NC			
A03	NC			
A02	COM			
A01	COM			

Input wiring (XBM-DN32S)

Circuit configuration		No.	Contact	No.	Contact	Type
	B10	00	A10	08		
	B09	01	A09	09		
	B08	02	A08	0A		
	B07	03	A07	0B		
	B06	04	A06	0C		
	B05	05	A05	0D		
	B04	06	A04	0E		
	B03	07	A03	0F		
	B02	COM	A02	COM		
	B01	COM	A01	COM		

Transistor output wiring (XBM-DN32S)

Circuit configuration		No.	Contact	Type
	B10	20		
	B09	21		
	B08	22		
	B07	23		
	B06	24		
	B05	25		
	B04	26		
	B03	27		
	B02	DC12/24V		
	B01	24V		
	A10	28		
	A09	29		
	A08	2A		
	A07	2B		
	A06	2C		
	A05	2D		
	A04	2E		
	A03	2F		
	A02	COM		
	A01	COM		



Application

XGB Series

C o n t e n t s

Input/Output specification	64
Names and functions	71
Built-in functions	75
Expansion	86
DC Input	86
Transistor Output	87
Relay Output	88
DC Input/Relay Output	89
Analog Input	91
Analog Output	92
Analog Input/Output	93
RTD	94
Thermocouple	95
Temperature controller module	96
Load Cell input module	98
Positioning module	99
EtherCAT positioning module	100
High Speed counter module	102
Modular type	103
Communication	104
Option modules/Smart link	108
Software	109
XGT Panel iXP2 Series	110
XGT Panel iXP Series	111
XGT Panel eXP2 Series	112
XGT Panel eXP Series	113
XGT Panel XP Series	114
Product list	115
Dimension	118





U type

Input specification

Item	XEC-DN32U/XEC-DN32UP/XEC-DN32UA XEC-DR28U/XEC-DR28UP/XEC-DR28UA
Input point	16 point
Insulation method	Photo coupler insulation
Rated input voltage	DC24V
Rated input current	About 4mA (Contact point 0~3: about 7mA)
Operation voltage range	DC20.4~28.8V (within ripple rate 5%)
On voltage / On current	DC19V or higher / 3mA or higher
Off voltage / Off current	DC6V or lower / 1mA or lower
Input resistance	About 5.6kΩ (P00~P07: about 4.7kΩ)
Response time	Off → On
	On → Off
	1/3/5/10/20/70/100ms (Set by I/O parameter) Default: 3ms
Insulation pressure	AC560Vrms/3 cycle (altitude 2000m)
Insulation resistance	10ms or more by MegOhmMeter
Common method	16 point/COM
Proper cable size	0.3~0.75mm ²
Operation indicator	LED On when Input On
External connection method	8 point terminal block + 10point terminal connector
Weight	571g

Transistor output specification

Item	XEC-DN32U/XEC-DN32UP/XEC-DN32UA
Output point	16 point
Insulation method	Photo coupler insulation
Rated load voltage	DC 12/24V
Operation load voltage range	DC 10.2 ~ 26.4V
Max. load current	0.5A/1 point, 2A/1COM
Off leakage current	0.1mA or less
Max. inrush current	4A/10ms or less
Max. voltage drop when On	DC 0.4V or less
Surge absorber	Zener diode
Response time	Off → On
	On → Off
	1ms or less 1ms or less (rated load, resistive load)
Common method	16 point/COM
Proper wire size	Stranded wire 0.3~0.75mm ² (external diameter 2.8mm or less)
External power	Voltage
	Current
	DC12/24V ± 10% (Ripple voltage 4 Vp-p or less) 10mA or less (When connecting DC24V)
Operation indicator	LED On when Output On
External connection method	8 point terminal block connector + 10 point terminal block connector
Weight	571g

High performance type

Input specification

Item	XBC/XEC-DR32H	XBC/XEC-DN32H XEC-DP32H	XBC/XEC-DR64H	XBC/XEC-DN64H XEC-DP64H	XEC-DR32H/D1 XEC-DR64H/D1
Input points	16 points		32 points		16 points
Rated input voltage	DC 24V				DC 12/24V
Rated input current	4mA (Contact 0~7: 9mA)				5/10mA (Contact 0~7 : 7/15mA)
Operation voltage range	DC 20.4 ~ 28.8V (Ripple rate < 5%)				DC 9.5~30V (Ripple rate < 5%)
On voltage / On current	DC 19V or more/3mA or more				DC 9V or more/3mA or more
Off voltage / Off current	DC 6V or less/1mA or less				DC 5V or less/1mA or less
Input resistance	5.6kΩ(P00 ~ P07: 2.7kΩ)				2.7kΩ(%IX0.0.0~%IX0.0.7:1.8kΩ)
Response time	Off → On	1/3/5/10/20/70/100 ms (Setting by CPU parameter) Initial value: 3ms			
	On → Off				

Relay output specification

Item	XBC/XEC-DR32H	XBC/XEC-DR64H
Output point	16 points	32 points
Insulation method	Relay insulation	
Rated load voltage / current	DC 24V 2A (Resistive load)/AC 220V 2A (COS ϕ = 1), 5A/COM	
Min. load voltage / current	DC 5V/1mA	
Max. load voltage	AC 250V, DC 125V	
Off leakage current	0.1mA (AC 220V, 60Hz)	
Max. On / Off frequency	3,600 times/hr	
Service life	Mechanical	20millions times or more
	Electrical	Rated load voltage/current 100,000 times or more
		AC 200V/1.5A, AC 240V/1A (COS ϕ = 0.7) 100,000 times or more
		AC 200V/1A, AC 240V/0.5A (COS ϕ = 0.35) 100,000 times or more
	DC 24V/1A, DC 100V/0.1A (L / R = 7ms) 100,000 times or more	
Response time	Off → On	10ms or less
	On → Off	12ms or less
Common method	4 points/COM	P20 ~ 2F: 4 points/COM P30 ~ 3F: 8 points/COM

Transistor output specification

Item	XBC-DN32H/XEC-DN(P)32H	XBC-DN64H/XEC-DN(P)64H
Output point	16 points	32 points
Insulation method	Photo coupler insulation	
Rated load voltage	DC 12/24V	
Load voltage range	DC 10.2 ~ 26.4 V	
Max. load voltage	0.5A / 1point (P20 ~ 23: 0.1A/point)	
Off leakage current	0.1mA or less	
Max. inrush current	4A/10ms or less	
Max. voltage drop (On)	DC 0.4V or less	
Surge absorber	Zener Diode	
Response time	Off → On	1ms or less
	On → Off	1ms or less (Rated load, resistive load)
Common method	4 points/COM	P20 ~ 2F: 4 points/COM P30 ~ 3F: 8 points/COM
External power supply	Voltage	DC 12/24V \pm 10% (Ripple voltage 4 Vp-p or less)
	Current	10mA or less (DC 24V connection)

Standard type

Input specification

Item	XBC/XEC-DN20SU	XBC/XEC-DN30SU	XBC/XEC-DN40SU	XBC/XEC-DN60SU
	XBC/XEC-DR20SU	XBC/XEC-DR30SU	XBC/XEC-DR40SU	XBC/XEC-DR60SU
Input point	12 points	18 points	24 points	36 points
Rated input voltage	DC 24V			
Rated input current	4mA (Contact point 0~1:16mA, 2~7:10mA), DN20SU (DN30SU) : 4mA (Contact point 0~7: 10mA)			
Operation voltage range	DC 20.4 ~ 28.8V (Ripple rate < 5%)			
On voltage / On current	DC 19V or more/3mA or more			
Off voltage / Off current	DC 6V or less/1mA or less			
Input resistance	5.6kΩ(P00 ~ P07 : 2.7kΩ)			
Response time	Off → On	1/3/5/10/20/70/100ms (Setting by CPU parameter) Initial value : 3ms		
	On → Off			

Transistor output specification (Sink/Source type)

Item	XBC/XEC-DN20SU	XBC/XEC-DN30SU	XBC/XEC-DN40SU	XBC/XEC-DN60SU
	XBC/XEC-DR20SU	XBC/XEC-DR30SU	XBC/XEC-DR40SU	XBC/XEC-DR60SU
	XBC/XEC-DP20SU	XBC/XEC-DP30SU	XBC/XEC-DP40SU	XBC/XEC-DP60SU
Output point	8 points	12 points	16 points	24 points
Insulation method	Photo coupler insulation			
Rated load voltage	DC 12/24V			
Load voltage range	DC 10.2 ~ 26.4V			
Max. load voltage	0.5A/1 point, 2A/ 1COM			
Off leakage current	0.1mA or less			
Max. inrush current	4A/10ms or less			
Max voltage drop (on)	DC 0.4V or less			
Surge absorber	Zener Diode			
Response time	Off → On	DC 12/24V± 10% (Ripple voltage 4Vp-p or less)		
	On → Off	25mA or less (DC 24V connection)		

Relay output specification

Item	XBC/XEC-DR20SU	XBC/XEC-DR30SU	XBC/XEC-DR40SU	XBC/XEC-DR60SU
	Output point	8 points	12 points	16 points
Insulation method	Relay insulation			
Rated load voltage/current	DC 24V 2A/AC 220V 2A (COSØ = 1), 5A/COM			
Min. load voltage/current	DC 5V/1mA			
Max. load Current	AC 250V, DC 125V			
Off leakage current	0.1mA (AC 220V, 60Hz)			
Surge absorber	-			
Response time	Off → On	10ms or less		
	On → Off	12ms or less		
Common method (/ COM)	4 points/COM (P40, P41 : 1 point/COM), (P42 P43 : 2 points/COM)			
Life-cycle	Mechanical	Rated load voltage/Current 10 million times or more		
	Electrical	AC 220V/1.5A, AC 240V/1A (COSØ= 0.7) 10 million times or more		
		AC 200V/1A, AC 240V/0.5A (COSØ= 0.35) 10 million times or more		
		DC 24V/1A, DC 100V/0.1A (L/ R = 7ms) 10 million times or more		

Economic type

Input specification

Specification	Modal	Main unit			
		XBC/XEC-DR10E XBC/XEC-DN10E	XBC/XEC-DR14E XBC/XEC-DN14E	XBC/XEC-DR20E XBC/XEC-DN20E	XBC/XEC-DR30E XBC/XEC-DN30E
Input point		6 points	8 points	12 points	18 points
Insulation method		Photo coupler insulation			
Rated input voltage		DC 24V			
Rated input current		About 4mA (Contact point 0~3: about 7mA)			
Operation voltage range		DC 20.4~28.8V (Within ripple rate 5%)			
On voltage / On current		DC 19V or higher / 3mA or higher			
Off voltage / Off current		DC 6V or lower / 1mA or lower			
Input resistance		About 5.6kΩ (%I × 0.0.0~%I × 0.0.3: about 2.7kΩ)			
Response time	Off → On	1 / 3 / 5 / 10 / 20 / 70 / 100ms (Set by I/O parameter) Default: 3ms			
	On → Off				
Insulation pressure		AC 560Vrms / 3 cycle (Altitude 2000m)			
Insulation resistance		10kΩ or more by MegOhmMeter			
Common method		6 points / COM	8 points / COM	12 points / COM	18 points / COM
Proper cable size		0.3mm ²			
Operation indicator		LED On when Input On			
External connection method		14 point terminal block connector (M3×6 screw)		24 point terminal block connector (M3×6 screw)	
Weight		330g	340g	450g	465g
		313g	315g	418g	423g

Relay output specification

Specification	Modal	Main unit			
		XBC/XEC-DR10E	XBC/XEC-DR14E	XBC/XEC-DR20E	XBC/XEC-DR30E
Output point		4 points	6 points	8 points	12 points
Insulation method		Relay insulation			
Rated load voltage/Current		DC 24V 2A (resistive load) / AC 220V 2A (COSφ = 1), 5A / COM			
Min. load voltage/Current		DC 5V / 1mA			
Max. load voltage		AC 250V, DC 125V			
Off leakage current		0.1mA (AC 220V, 60Hz)			
Max. On/Off frequency		3,600 times / hour			
Surge absorber		None			
Service life	Mechanical	20 million times or more			
	Electrical	Rated load voltage / Current 100,000 times or more			
		AC 200V / 1.5A, AC 240V / 1A (COØ = 0.7) 100,000 times or more			
		AC 200V / 1A, AC 240V / 0.5A (COØ = 0.35) 100,000 times or more			
		DC 24V / 1A, DC 100V / 0.1A (L/R = 7ms) 100,000 times or more			
Response time	Off → On	10ms or less			
	On → Off	12ms or less			
Common method		2 points / COM	4 points / COM	4 points / COM	4 points / COM
Proper cable size		Stranded cable 0.3~0.75mm ² (External diameter 2.8mm or less)			
Operation indicator		LED On when Output On			
External connection method		14 point terminal block connector (M3×6 screw)		24 point terminal block connector (M3×6 screw)	

Economic type

Transistor output specification
(Sink/Source type)

Specification	Modal	Main unit			
		XBC/XEC-DN10E XBC/XEC-DP10E	XBC/XEC-DN14E XBC/XEC-DP14E	XBC/XEC-DN20E XBC/XEC-DP20E	XBC/XEC-DN30E XBC/XEC-DP30E
Output point		4 points	6 points	8 points	12 points
Insulation method		Photo coupler insulation			
Rated load voltage		DC 12/24V			
Operation load voltage range		DC 10.2~26.4V			
Max. load current		0.5A/1 point, 2A/1COM			
Off leakage current		0.1mA or less			
Max. inrush current		4A/10ms or less			
Max. voltage drop when On		DC 0.4V or less			
Surge absorber		Zener diode			
Response time	Off → On	1ms less			
	On → Off	1ms less (Rated load, resistive load)			
Common method		4 point / COM			
Proper wire size		Stranded wire 0.3~0.75mm ² (External diameter 2.8mm or less)			
External power	Voltage	DC 12/24V ± 10% (Ripple voltage 4 Vp-p or less)			
	Current	25mA or less (When connecting DC 24V)			
Operation indicator		LED On when Output On			
External connection method		14 point terminal block connector (M3 × 6 screw)		24 point terminal block connector (M3 × 6 screw)	

Slim type

XBM H Input specification

Model		Main unit
Specification		XBM-DN32H
Input point		16 point
Insulation method		Photo coupler insulation
Rated input voltage		DC24V
Rated input current		About 4mA (Contact point 0~3: about 5mA)
Operation voltage range		DC20.4~28.8V (within ripple rate 5%)
On voltage / On current		DC19V or higher / 3mA or higher
Off voltage / Off current		DC6V or lower / 1mA or lower
Input resistance		About 5.6kΩ / (P00~P03: about 4.7kΩ)
Response time	Off → On	1/3/5/10/20/70/100ms (Set by I/O parameter) Default: 3ms
	On → Off	
Insulation pressure		AC560Vrms / 3 cycle (altitude 2000m)
Insulation resistance		10MΩ or more by MegOhmMeter
Common method		16 point / COM
Proper cable size		0.3~0.75mm ²
Operation indicator		LED On when Input On
External connection method		40point terminal connector
Weight		134g

Transistor output specification

Model		Main unit
Specification		XBM-DN32H
Output point		16 point
Insulation method		Photo coupler insulation
Rated load voltage		DC 12/24V
Operation load voltage range		DC 10.2 ~ 26.4V
Max. load current		0.5A / 1 point, position (p00,p01,p02,p03) 0.1A/1 point 2A / 1COM
Off leakage current		0.1mA or less
Max. inrush current		4A / 10ms or less
Max. voltage drop when On		DC 0.4V or less
Surge absorber		Zener diode
Response time	Off → On	1ms or less (rated load, resistive load)
	On → Off	
Common method		16 point / COM
Proper wire size		Stranded wire 0.3~0.75mm ² (external diameter 2.8mm or less)
External power	Voltage	DC12/24V ±10% (Ripple voltage 4 Vp-p or less)
	Current	
Operation indicator		LED On when Output On
External connection method		4 point terminal block connector
Weight		134g

Slim type

Input specification

Item	XBM-DR16S	XBM-DN16S	XBM-DN32S
Input point	8 points	8 points	16 points
Rated input voltage	DC 24V		
Rated input current	4mA (00 ~ 03: 7mA)		
Operation voltage range	DC 20.4 ~ 28.8V (Ripple rate < 5%)		
Response time	1/3/5/10/20/70/100ms		
	(Set by CPU parameter) Default : 3ms		
Common method	8 points/COM		16 points/COM

Relay output specification

Item	XBM-DR16S	
Output point	8 points	
Insulation method	Relay insulation	
Rated load voltage / current	DC 24V 2A (Resistive load)/AC 220V 2A (COS ϕ = 1), 5A/COM	
Min. load voltage / current	DC 5V/1mA	
Max. load voltage	AC 250V, DC 125V	
Off leakage current	0.1mA (AC 220V, 60Hz)	
Max. On / Off frequency	3,600 times/hr	
Service life	Mechanical	20 millions times or more
	Electrical	Rated load voltage/Current 100,000 times or more
		AC 200V/1.5A, AC 240V/1A (COS ϕ = 0.7) 100,000 times or more
		AC 200V/1A, AC 240V/0.5A (COS ϕ = 0.35) 100,000 times or more
	DC 24V/1A, DC 100V/0.1A (L / R = 7ms) 100,000 times or more	
Response time	Off \rightarrow On	10ms or less
	On \rightarrow Off	12ms or less
Common method	8 points / COM	

Transistor output specification

Item	XBM-DN16S	XBM-DN32S
Output point	8 point	16 point
Insulation method	Photo coupler insulation	
Rated load voltage	DC 12/24V	
Load voltage range	DC 10.2 ~ 26.4V	
Max. load voltage	0.2A/1 point (P20 ~ 23: 0.1A/Point)	
Max. inrush current	4A/10ms or less	
Max. voltage drop (On)	DC 0.4V or less	
Response time	1ms or less	
	1ms or less (Rated load, Resistive load)	
Common method	8 point / COM	16 point / COM
External power supply	DC 12/24V \pm 10% (Ripple voltage 4 Vp-p or less)	
	25mA or less (DC 24V connection)	
External connection method	20pin connector	

Block type unit (U)

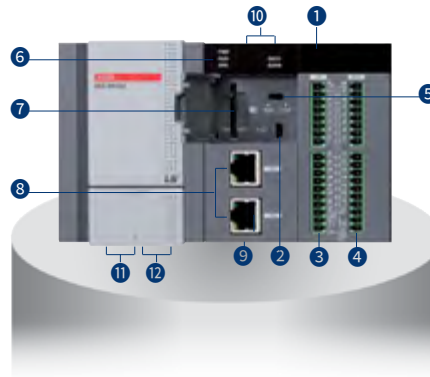

No.	Name	Descriptions	Remark
①	LED for displaying input, output	Displays the On/Off status of input, output contacts	
②	Connector for PADT	Connector (USB 1channel) to access to XG5000	
③	Input terminal block	Terminal block receiving the actual input signal	
④	Output terminal block	Terminal block outputting the actual output signal	
⑤	RUN/STOP mode switch	Sets the basic unit's operation mode. - STOP → RUN : Program's operation is executed. - RUN → STOP : Program's operation is stopped. (In case of STOP, the remote operation is available.)	
⑥	Status display LED	Displays the basic unit's operation status. - PWR (Red light On) : The power is supplied. - RUN (Green light On) : During RUN mode - ERR (Flickering red light) : Occurrence of errors during operation - STATE (Red light On/flickering Red light): When the SD card is installed, the red light is turned On; when the SD card error occurs, the red light is flickering. - RD/WR (Flickering red light) : During SD card Write	
⑦	SD card connector	Connector with the SD memory card	
⑧	Terminal block for the embedded Enet communication	Terminal block for the embedded Enet communication	
⑨	Terminal block for the embedded communication	Terminal block (lower part of the product) for the embedded RS-232C/485 communication	
⑩	Battery holder	Battery holder (upper part of the product)	
⑪	Power terminal block	Terminal block (AC 100 ~ 240V or DC24V) for power supply	
⑫	24V output	Terminal block with DC 24V output(Not supported on DC type)	

Block type unit
(High performance,
Standard, Economic)

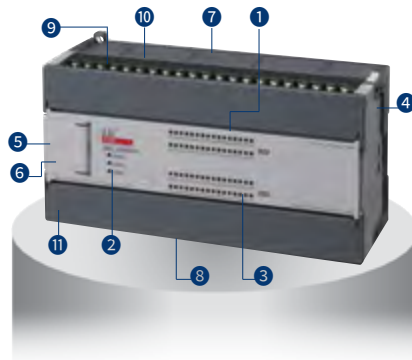

No.	Name	Descriptions	Descriptions	Remark
①	Input LED	Input indication	Red On: Input signal On Red Off: Input signal Off	
②	Condition LED	PWR: Power indication	Red On: Power On Red Off: Power Off	
		RUN: RUN indication	Green On: PLC Run Green Off: PLC Stop	
		ERR: Error indication	Red On-and-Off: PLC Error Red Off: PLC Normal condition	
③	Output LED	Output LED	On: Output signal On Off: Output signal Off	
④	Expansion module connector	Expansion module connector	Connection of expansion module (I/O, Special function, Communication)	
⑤	PADT connector	PADT connection	Connector for XG5000/XG-PD connection	
⑥	Mode switch	Mode setting	Setting Run/Stop mode of PLC	
⑦	Input terminal block	Input wiring connection	-	
⑧	Output terminal block	Output wiring connection	-	
⑨	Built-in RS-485 connector	Built-in RS-485 connection	RS-485 +/- terminal connection	
⑩	Built-in RS-232C connector	Built-in RS-232C connection	RS-232C T×D, R×D, SG terminal connection	
⑪	Power terminal	Power supply terminal	AC 100 ~ 240V or DC24V power supply	
⑫	Option module slot	Slot for option module	-	

Modular type unit
(XBM-DN32H)

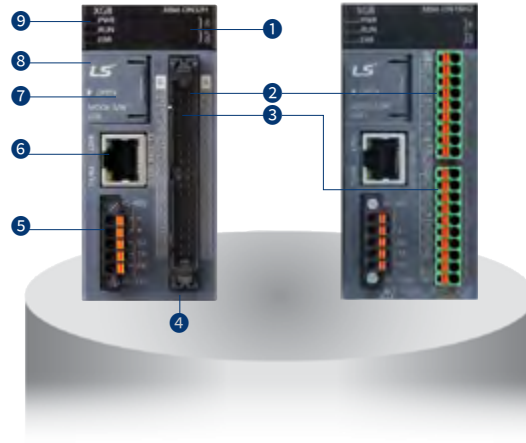

No.	Name	Descriptions
1	LED for displaying input, output	Displays the On/Off status of input, output contacts
2	Input connector	Terminal block receiving the actual input signal
3	Output connector	Terminal block outputting the actual output signal
4	Power supply connector	Power supply connector (24V)
5	Built-in serial communication connecting connector	Built-in RS-232C/485 connecting connector
6	Built-in ethernet connecting connector	Built-in Enet connecting connector
7	PADT connecting connector	PADT connecting connector
8	RUN/STOP mode switch	<ul style="list-style-type: none"> •Sets the basic unit's operation mode. - STOP MRUN : Program's operation is executed. - RUN MSTOP : Program's operation is stopped. (In case of STOP, the remote operation is available.)
9	Status display LED	<ul style="list-style-type: none"> •Displays the basic unit's operation status. - PWR(Red light On) : The power is supplied. - RUN(Green light On) : During RUN mode - ERR(Flickering red light) : Occurrence of errors during operation - STATE(Red light On/flickering Red light): When the SD card is installed, the red light is turned On; when the SD card error occurs, the red light is flickering. - RD/WR(Flickering red light) : During SD card Write

Modular type unit (XBM-DR16S, DN16S, DN32S)

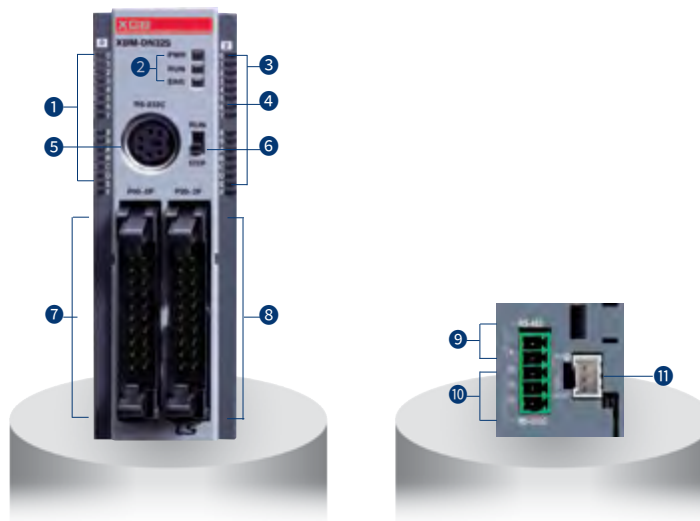

No.	Name	Descriptions	Descriptions	Remark
①	Input LED	Input indication	Red On: Input signal On Red Off: Input signal Off	
②	Condition LED	PWR: Power indication	Red On: Power On Red Off: Power Off	
		RUN: RUN indication	Green On: PLC Run Green Off: PLC Stop	
		ERR: Error indication	Red On-and-Off: PLC Error Red Off: PLC Normal condition	
③	Output LED	Output LED	On: Output signal On Off: Output signal Off	
④	Expansion module connector	Expansion module connector	Connection of expansion module (I/O, Special function, Communication)	
⑤	PADT connector	PADT connection	Connector for XG5000/XG-PD connection	
⑥	Mode switch	Mode setting	Setting Run / Stop mode of PLC	
⑦	Input connector / Terminal block	Input wiring connection	-	
⑧	Output connector / Terminal block	Output wiring connection	-	
⑨	Built-in RS-485 connector	Built-in RS-485 connection	RS-485 +/- terminal connection	
⑩	Built-in RS-232C connector	Built-in RS-232C connection	RS-232C T×D, R×D, SG terminal connection	
⑪	Power connector	Power supply connection	DC 24V power supply	

Built-in functions

XGB U

Performance specifications

Items		Specification	Remark
PID control		Control by instruction, auto-tuning, PWM output, Forced output, Operation scan time setting, Antiwindup, Delta MV, PV tracking, Hybrid operation, Cascade operation	
Serial	Protocol	Dedicated protocol, Modbus protocol User defined protocol , LS bus (inverter protocol)	Embedded00 P2P:01
	Channel	RS-232C 1 port and RS-485 1 port	
Ethernet	Transfer spec	Cable: 100Base-TX Speed: 100Mbps Auto-MDIX* ¹ IEEE 802.3	
	Topology	Line, star	
	Diagnosis	Module information, service condition	
	Protocol	XGT dedicated Modbus TCP/IP user define frame	Embedded01 P2P:02 High-speed link:01
Service	P2P, High Speed link, Remote connection		
Datalog	Group	Max 10 group	
	Data set	32 per group	
	Extension	csv file	
	File size	Max 16Mbyte	
	SD memory type	SD,SDHC type (Recommand: SanDisk, Transcend)	
	Memory size	Max 16GB	
	File system	FAT32	
High speed counter	Performance	1-phase : 100MHz 8 channels 2-phase : 50MHz 4 channels	
	Counter mode	4 counter modes are supported based on input pulse and INC/DEC method <ul style="list-style-type: none"> • 1 pulse operation Mode : INC/DEC count by program • 1 pulse operation Mode : INC/DEC count by phase B pulse input • 2 pulse operation Mode : INC/DEC count by input pulse • 2 pulse operation Mode : INC/DEC count by difference of phase 	
	Function	<ul style="list-style-type: none"> • Internal/external preset • Latch counter • Compare output • No. of rotation per unit time 	

*1 Auto-MDIX (Automatic medium-dependent interface crossover) :

It is the function to automatically detect whether the cable connected to the Ethernet port is peer-to-peer (straight) or cross cable

XGB U

Built-in positioning function (XBC/XEC-DxxxUP)

Items	Specification	Remark
Basic function	No. of control axi: 4axis Control Method:Position, Speed, Speed/Position, Feed Control Control Unit: Pulse ,mm, inch, degree Positioning Data: Each axis can have up to 400 data (Step number:1~400) Operation pattern: End, Keep, Continuous Operation method: Singular, Repeat	Availavle on Analog
Interpolation	2/3/4 axis linear interpolation 2 axis circular interpolation 3 axis helical interpolation	
Positioning	Method: Absolute/Incremental method Address range: 2, 147, 483, 648~2, 147, 483, 647 Speed: Max 2Mpps (1~2,000,000pps) Acc /Dec process: Trapezoid type, S-type	
Homing method	DOG+HOME (Off), DOG+HOME (On), Upper limit + HOME, DOG, High speed, Upper/Lower limit, HOME	
Manual operation	Jog operation, MPG operation, Inching operation	
Encoder input	Line drive (RS-422A) input 1Channel (Max 200kpps)	

Built-in analog function (XBC/XEC-DxxxUA)

Items	Specification	Remark			
Analog input	Channels	4channels (current/voltage)	Availavle on Analog		
	Specification	Input Range		Voltage: 1~5V, 0~5V, 0~10V, -10~10V Current: 4~20mA, 0~20mA Current input or Voltage input can be selected through the external terminal wiring setting.	
		Input resistance		1MΩ or more (voltage input), 250Ω (current input)	
		Max. resolution		1/16000	
				0.250mV (1 ~ 5V) 0.3125mV (0 ~ 5V) 0.625mV (0 ~ 10V) 1.250mV (±10V)	1.0μA (4 ~ 20mA) 1.25μA (0 ~ 20mA)
Accuracy	±0.2% or less (When ambient temperature is 25°C) ±0.3% or less (When ambient temperature is 0 ~ 55°C)				
Analog output	Channels	Voltage 2 channels ,Current 2 channels		Availavle on Analog	
	Specification	Output Range			Voltage: 1~5V, 0~5V, 0~10V, -10~10V Current: 4~20mA, 0~20mA Output ranges are set in user program or I/O parameter per each channel.
		Load resistance			1MΩ or more(voltage output), 600Ω or less(current output)
		Max. resolution			1/16000
			0.250mV (1 ~ 5V) 0.3125mV (0 ~ 5V) 0.625mV (0 ~ 10V) 1.250mV (±10V)		1.0μA (4 ~ 20mA) 1.25μA (0 ~ 20mA)
Accuracy	±0.2% or less (When ambient temperature is 25°C) ±0.3% or less (When ambient temperature is 0 ~ 55°C)				

XGB H/SU/E, XBM S

Performance specifications

Classification		Description			
		Block type unit			Modular type
		H	SU	E	XBM
Count input Signal	Signal	A-phase, B-phase			
	Input type	Voltage input (Open collector)			
	Signal level	DC 24V			
Max. count speed		100kpps	100kpps	4kpps	20kpps
Number of channels	1 phase	100kpps 4ch/20kpps 4ch	100kpps 2ch/20kpps 6ch	4kpps 4ch	20kpps 4ch
	2 phase	50kpps 2ch/10kpps 2ch	50kpps 1ch	2kpps 2ch	2 multiplication: 10kpps
		50kpps 2ch/8kpps 2ch	8kpps 3ch		4 multiplication: 8kpps
Count range		Signed 32bit (-2,147,483,648 ~ 2,147,483,647)			
Count mode (Program setting)		Linear count (If 32bit range exceeded, Carry / Borrow occurs) Ring count (Repeated count within setting range)			
Input mode (Program setting)		1-phase input 2-phase input CW/CCW input			
Signal type		Voltage			
Up/Down setting	1 phase input	Increasing/Decreasing operation setting by B-phase input			
		Increasing/Decreasing operation setting by program			
	2 phase input	Automatic setting by difference in phase			
CW/CCW	A-phase input: increasing operation				
	B-phase input: decreasing operation				
Multiplication function	1 phase input	1 multiplication			
	2 phase input	4 multiplication			
	CW/CCW	1 multiplication			
Control input	Signal	Preset instruction input			
	Signal level	DC 24V input type			
	Signal type	Voltage			
External output	Output points	2 point / channel (for each channel): output contact point of basic unit available		1 point / channel (for each channel): output contact point of basic unit available	
		Type			
	Output type	Relay, Open-collector output (Sink)			
Count enable		To be set through program			
Preset function		To be set through terminal (contact) or program			
Auxiliary mode		Count latch			

Input specification

Item	Description
Input voltage	24V DC (20.4V ~ 28.8V)
Input current	4mA
On voltage (min.)	20.4V
Off voltage (max.)	6V

XBM HP

Built in function

Items		Specification	Remark
		XBM-DN32HP	
PID control		Control by instruction, auto-tuning, PWM output, Forced output, Operation scan time setting, Antiwindup, Delta MV, SV lamp, Hybrid operation, Cascade operation	
Cnet	PID control	Dedicated protocol(XGT) Modbus protocol User defined protocol , LS bus(inverter protocol)	
	Channel	RS-232C 1 port and RS-485 1 port	
Enet	Transfer spec	Cable: 100Base-TX Speed: 100Mbps Auto-MDIX ^{*1} IEEE 802.3	
	Topology	Star	
	Diagnosis	Module information, Service condition	
	Protocol	XGT dedicated, Modbus TCP/IP, user define frame	
	Service	P2P, High Speed link, Remote connection, SMTP, SNTP, Auto scan	
High Speed Counte	Performance	1 phase: 200kHz(2 phase: 100kHz)	
	channels	1phase 4 channels, 2 phase 2 channels	
	Counter mode	4 counter modes are supported based on input pulse and INC/DEC method <ul style="list-style-type: none"> • 1 pulse operation Mode : INC/DEC count by program • 1 pulse operation Mode : INC/DEC count by phase B pulse input • 2 pulse operation Mode : INC/DEC count by input pulse • 2 pulse operation Mode : INC/DEC count by difference of phase 	
	Function	<ul style="list-style-type: none"> • Internal/external preset • Latch counter • Compare output • No. of rotation per unit time 	
Position	Basic function	No. of control axis: 2axis Pulse output type : pulse+ direction Position data: 80 steps for each axis(1~80) Operation mode: end, keep, continuous Operation method: single, repeat	
	Interpolation function	<ul style="list-style-type: none"> • 2/3/4/5/6 axis linear interpolation(XBMH: 2 axis linear interpolation) • 2 axis circular interpolation • 3 axis helical interpolation(not supported in XBMH) 	
	Position	Absolute method / Incremental method Position address range: -2,147,483,648 ~ 2,147,483,647(Pulse) Speed range: 1~100,000pps(1pps unit) Acc/dec processing: Trapezoid-shaped	
	Origin return method	DOG + HOME (Off), DOG + HOME(On), Upper/Lower limit + HOME, DOG, High speed, Upper/Lower limit, HOME	
	Jog operation	Jog Operation, MPG Operation, Inching Operation	
Pulse catch		10μs 4point(P0000 ~ P0003), 50μs 4point(P0004 ~ P0007)	
External point Interrupt		10μs 4point(P0000 ~ P0003), 50μs 4point(P0004 ~ P0007)	
Input filter		1,3,5,10,20,70,100ms	

*1 Auto-MDIX(Automatic medium-dependent interface crossover) : It is the function to automatically detect whether the cable connected to the Ethernet port is peer-to-peer(straight) or cross cable

XBM H

Built in function

Items		Specification	Remark
		XBM-DN32H	
Built-in Function	PID control		Control by instruction, auto-tuning, PWM output, Forced output, Operation scan time setting, Antiwindup, Delta MV, SV lamp, Hybrid operation, Cascade operation
	Cnet	PID control	Dedicated protocol(XGT) Modbus protocol User defined protocol , LS bus(inverter protocol)
		Channel	RS-232C 1 port and RS-485 1 port
	Enet	Transfer spec	Cable: 100Base-TX Speed: 100Mbps Auto-MDIX ^{*1} IEEE 802.3
		Topology	Star
		Diagnosis	Module information, Service condition
		Protocol	XGT dedicated, Modbus TCP/IP, user define frame
		Service	P2P, High Speed link, Remote connection, SMTP, SNTP, Auto scan
	High Speed Counte	Performance	1 phase: 200kHz(2 phase: 100kHz)
		channels	1phase 4 channels, 2 phase 2 channels
		Counter mode	4 counter modes are supported based on input pulse and INC/DEC method <ul style="list-style-type: none"> • 1 pulse operation Mode : INC/DEC count by program • 1 pulse operation Mode : INC/DEC count by phase B pulse input • 2 pulse operation Mode : INC/DEC count by input pulse • 2 pulse operation Mode : INC/DEC count by difference of phase
		Function	<ul style="list-style-type: none"> • Internal/external preset • Latch counter • Compare output • No. of rotation per unit time
	Position	Basic function	No. of control axis: 2axis Pulse output type : pulse+ direction Position data: 80 steps for each axis(1~80) Operation mode: end, keep, continuous Operation method: single, repeat
		Interpolation function	2/3/4/5/6 axis linear interpolation(XBMH: 2 axis linear interpolation) 2 axis circular interpolation 3 axis helical interpolation(not supported in XBMH)
		Position	Absolute method / Incremental method Position address range: -2,147,483,648 ~ 2,147,483,647(Pulse) Speed range: 1~100,000pps(1pps unit) Acc/dec processing: Trapezoid-shaped
		Origin return method	DOG + HOME (Off), DOG + HOME(On), Upper/Lower limit + HOME, DOG, High speed, Upper/Lower limit, HOME
		Jog operation	Jog Operation, MPG Operation, Inching Operation
		Pulse catch	10μs 4point(P0000 ~ P0003), 50μs 4point(P0004 ~ P0007)
	External point Interrupt	10μs 4point(P0000 ~ P0003), 50μs 4point(P0004 ~ P0007)	
	Input filter	1,3,5,10,20,70,100ms	

*1 Auto-MDIX(Automatic medium-dependent interface crossover) : It is the function to automatically detect whether the cable connected to the Ethernet port is peer-to-peer(straight) or cross cable

Parts designation | Block type unit

High performance type (XBC-H)

Terminal No.	Name		Usage	
	1-phase	2-Phase	1-phase	2-Phase
P000	Ch0 counter input	Ch0 A-phase input	Counter input terminal	A-phase input
P001	Ch1 counter input	Ch0 B-phase input	Counter input terminal	B-phase input
P002	Ch2 counter input	Ch2 A-phase input	Counter input terminal	A-phase input
P003	Ch3 counter input	Ch2 B-phase input	Counter input terminal	B-phase input
P004	Ch4 counter input	Ch4 A-phase input	Counter input terminal	A-phase input
P005	Ch5 counter input	Ch4 B-phase input	Counter input terminal	B-phase input
P006	Ch6 counter input	Ch6 A-phase input	Counter input terminal	A-phase input
P007	Ch7 counter input	Ch6 B-phase input	Counter input terminal	B-phase input
P008	Ch0 preset 24V	Ch0 preset 24V	Preset input terminal	Preset input terminal
P009	Ch1 preset 24V	-	Preset input terminal	No use
P00A	Ch2 preset 24V	Ch2 preset 24V	Preset input terminal	Preset input terminal
P00B	Ch4 preset 24V	-	Preset input terminal	No use
P00C	Ch5 preset 24V	Ch4 preset 24V	Preset input terminal	Preset input terminal
P00D	Ch6 preset 24V	-	Preset input terminal	No use
P00E	Ch7 preset 24V	Ch6 preset 24V	Preset input terminal	Preset input terminal
P00F	Ch8 preset 24V	-	Preset input terminal	No use
COM0	Input common	Input common	Input common	Input common

High performance type (XEC-H)

Terminal No.	Name		Usage	
	1-phase	2-Phase	1-phase	2-Phase
IX0.0.0	Ch0 counter input	Ch0 A-phase input	Counter input terminal	A-phase input
IX0.0.1	Ch1 counter input	Ch0 B-phase input	Counter input terminal	B-phase input
IX0.0.2	Ch2 counter input	Ch2 A-phase input	Counter input terminal	A-phase input
IX0.0.3	Ch3 counter input	Ch2 B-phase input	Counter input terminal	B-phase input
IX0.0.4	Ch4 counter input	Ch4 A-phase input	Counter input terminal	A-phase input
IX0.0.5	Ch5 counter input	Ch4 B-phase input	Counter input terminal	B-phase input
IX0.0.6	Ch6 counter input	Ch6 A-phase input	Counter input terminal	A-phase input
IX0.0.7	Ch7 counter input	Ch6 B-phase input	Counter input terminal	B-phase input
IX0.0.8	Ch0 preset 24V	Ch0 preset 24V	Preset input terminal	Preset input terminal
IX0.0.9	Ch1 preset 24V	-	Preset input terminal	No use
IX0.0.10	Ch2 preset 24V	Ch2 preset 24V	Preset input terminal	Preset input terminal
IX0.0.11	Ch4 preset 24V	-	Preset input terminal	No use
IX0.0.12	Ch5 preset 24V	Ch4 preset 24V	Preset input terminal	Preset input terminal
IX0.0.13	Ch6 preset 24V	-	Preset input terminal	No use
IX0.0.14	Ch7 preset 24V	Ch6 preset 24V	Preset input terminal	Preset input terminal
IX0.0.15	Ch8 preset 24V	-	Preset input terminal	No use
COM0	Input common	Input common	Input common	Input common

Standard type (XBC-SU)

Terminal No.	Name		Usage	
	1-phase	2-Phase	1-phase	2-Phase
P000	Ch0 counter input	Ch0 A-phase input	Counter input terminal	A-phase input
P001	Ch1 counter input	Ch0 B-phase input	Counter input terminal	B-phase input
P002	Ch2 counter input	Ch2 A-phase input	Counter input terminal	A-phase input
P003	Ch3 counter input	Ch2 B-phase input	Counter input terminal	B-phase input
P004	Ch4 counter input	Ch4 A-phase input	Counter input terminal	A-phase input
P005	Ch5 counter input	Ch4 B-phase input	Counter input terminal	B-phase input
P006	Ch6 counter input	Ch6 A-phase input	Counter input terminal	A-phase input
P007	Ch7 counter input	Ch6 B-phase input	Counter input terminal	B-phase input
P008	Ch0 preset 24V	Ch0 preset 24V	Preset input terminal	Preset input terminal
P009	Ch1 preset 24V	-	Preset input terminal	No use
P00A	Ch2 preset 24V	Ch2 preset 24V	Preset input terminal	Preset input terminal
P00B	Ch4 preset 24V	-	Preset input terminal	No use
P00C	Ch5 preset 24V	Ch4 preset 24V	Preset input terminal	Preset input terminal
P00D	Ch6 preset 24V	-	Preset input terminal	No use
P00E	Ch7 preset 24V	Ch6 preset 24V	Preset input terminal	Preset input terminal
P00F	Ch8 preset 24V	-	Preset input terminal	No use
COM0	Input common	Input common	Input common	Input common

Parts designation | Block type unit

Economic type
(XBC-E)

Terminal No.	Name		Usage	
	1-phase	2-Phase	1-phase	2-Phase
P000	Ch0 counter input	Ch0 A-phase input	Counter input terminal	A-phase input
P001	Ch1 counter input	Ch0 B-phase input	Counter input terminal	B-phase input
P002	Ch2 counter input	Ch2 A-phase input	Counter input terminal	A-phase input
P003	Ch3 counter input	Ch2 B-phase input	Counter input terminal	B-phase input
P004	Ch0 preset 24V	Ch0 preset 24V	Preset input terminal	Preset input terminal
P005	Ch1 preset 24V	-	Preset input terminal	No use
P006	Ch2 preset 24V	Ch2 preset 24V	Preset input terminal	Preset input terminal
P007	Ch4 preset 24V	-	Preset input terminal	No use
COM0	Input common	Input common	Common terminal	Common terminal

Parts designation | Modular type unit

Modular type
(XBM)

Terminal No.	Name		Usage	
	1-phase	2-Phase	1-phase	2-Phase
P000	Ch0 counter input	Ch0 A-phase input	Counter input terminal	A-phase input
P001	Ch1 counter input	Ch0 B-phase input	Counter input terminal	B-phase input
P002	Ch2 counter input	Ch2 A-phase input	Counter input terminal	A-phase input
P003	Ch3 counter input	Ch2 B-phase input	Counter input terminal	B-phase input
P004	Ch0 preset 24V	Ch0 preset 24V	Preset input terminal	Preset input terminal
P005	Ch1 preset 24V	-	Preset input terminal	No use
P006	Ch2 preset 24V	Ch2 preset 24V	Preset input terminal	Preset input terminal
P007	Ch3 preset 24V	-	Preset input terminal	No use
COM0	Input common	Input common	Common terminal	Common terminal

Wiring

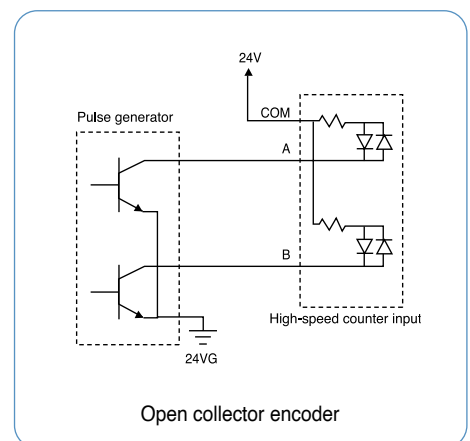
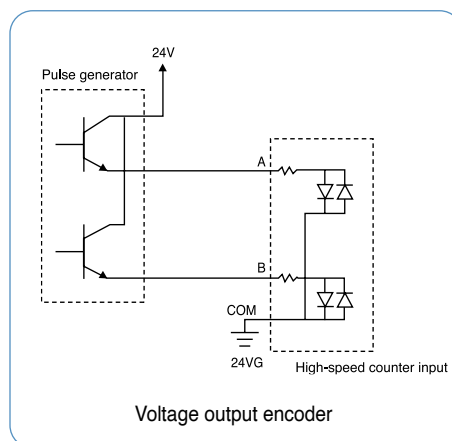

Performance specification

Classification	Description		
	Block type unit		Modular type
	H-type	SU-type	S-type
No. of control axis	2 axes		
Interpolation	2-axis linear interpolation		
Control mode	Position control, Speed control, Speed/Position switching control, Position/Speed switching control		
Control unit	Pulse		
Positioning data	30-step pattern for each axis (XBC: 80step) (operation step number : 1~30, XBC : 1~80)		
Positioning monitor	Dedicated monitoring function for positioning in XG5000		
Back-up	Permanent backup of downloaded parameter (FLASH memory)		
	2-month Super Cap.backup of parameter / Data modified during operation(XBM) battery back-up (XBC)		
	Permanent backup of parameter / Data in RAM by instruction (FLASH memory)		
Positioning	Positioning method	Absolute/incremental method	
	Positioning range	-2,147,483,648 ~ 2,147,483,647	
	Speed range	1 ~ 100,000 (pulse/sec)	
	Acceleration / Deceleration type	Trapezoidal acceleration/Deceleration	
	Acceleration / Deceleration time	1 ~ 10,000ms (4 patterns each can be set)	
Max. output pulse	100 Kpps		
Max. distance of connection	2m		

※ Economic block type unit (E-type) dose not support built-in positioning functions

Electrical specification

	Signal	Rated input voltage	Load voltage range	Max. load current/ Inrush current	Max. voltage drop (On)	Leakage current (Off)	Response time
Output	Output pulse	DC 5~24V	DC 4.75~26.4V	100mA (1 point) 1A/10ms or less	DC 0.3V or less	0.1mA or less	100μs or less
Input	Signal	Rated input voltage/Current	Load voltage range	On voltage/ Current	Off voltage/ Current	Input resistance	0.5ms or less
	External high limit						
	External low limit	DC 24V/4mA	DC 19V/3.4mA or more	DC 6V/1.1mA or less	5.6Ω		
	Approximate zero						
	zero						

I/O specifications | Block type unit

High performance type (XBC/XEC-H)

Item	XBC pin number (XEC pin number)		Signal name		Direction of positioning signal to external	Operating condition
	X axis	Y axis				
Input	P00008 (%IX0.0.8)	P0000A (%IX0.0.10)	Limit L	Low limit	←	4mA/ 24V
	P00009 (%IX0.0.9)	P0000B (%IX0.0.11)	Limit H	High limit	←	
	P0000C (%IX0.0.12)	P0000E (%IX0.0.14)	DOG	Near point	←	
	P0000D (%IX0.0.13)	P0000F (%IX0.0.15)	Origin	Zero signal (+24V)	←	
	COM		Input COM	Common	←	
Output	P00020 (%QX0.0.0)	P00021 (%QX0.0.1)	Pulse	Pulse/CW (Open collector)	→	DC 12~24V
	P00022 (%QX0.0.2)	P00023 (%QX0.0.3)	Direction	Direction/CCW (Open collector)	→	
	P		DC 12V~24V	External power supply	→	
	COM 0~3		Output COM	External 24V GND	→	

Standard type (XBC/XEC-SU)

Item	XBC pin number		Signal name		Direction of positioning signal to external	Operating condition
	X axis	Y axis				
Input	P00008 (%IX0.0.8)	P0000A (%IX0.0.10)	Limit L	Low limit	←	4mA/ 24V
	P00009 (%IX0.0.9)	P0000B (%IX0.0.11)	Limit H	High limit	←	
	P0000C (%IX0.0.12)	P0000E (%IX0.0.14)	DOG	Near point	←	
	P0000D (%IX0.0.13)	P0000F (%IX0.0.15)	Origin	Zero signal (+24V)	←	
	COM		Input COM	Common	←	
Output	P00040 (%QX0.0.0)	P00041 (%QX0.0.1)	Pulse	Pulse/CW (Open collector)	→	DC 12~24V
	P00042 (%QX0.0.2)	P00043 (%QX0.0.3)	Direction	Direction/CCW (Open collector)	→	
	P		DC 12V~24V	External power supply	→	
	COM 0~3		Output COM	External 24V GND	→	

I/O specifications | Modular type unit

Standard type

Item	XBM pin number		Signal name		Direction of positioning signal to external	Operating condition
	X axis	Y axis				
Input	P00000	P00002	Limit L	Low limit	←	Edge
	P00001	P00003	Limit H	High limit	←	Edge
	P00004	P00006	DOG	Near point	←	Edge
	P00005	P00007	Origin	Zero signal (+24V)	←	Edge
	COM		Input COM	Common	←	-
Output	P00020	P00021	Pulse	Pulse/CW (Open collector)	→	-
	P00022	P00023	Direction	Direction/CCW (Open collector)	→	-
	12/24V		DC 12/24V	External power supply	→	-
	COM		Output COM	External 24V GND	→	-

Performance specification

(PID)

Classification	Description		
	Block type unit		Modular type
	H	SU	S
No. of control loop	16-loop independent control		
Control mode	P control, PI control, PD control, PID control		
Control period	10ms ~ 6,553.5ms (Setting unit: 0.1ms)		
Function	Forward/Reverse Mixed control	Switching control direction automatically when exceeding dead band	
	Cascade	Improved control precision by serial connection between master loop and slave loop	
	SV Ramp	Preventing overload caused by excessive SV change by setting variation slope	
	Alarm	Improved control stability with various alarm function such as MV high limit / Low limit, PV high limit/low limit, PV variation width	
	Auto tuning	Auto tuning with improved auto-tuning algorithm	
	Additional function	PWM output, PV Tracking, ΔMV, ΔPV, etc	

※ Economic block type unit (E-type) does not support built-in PID functions

Pulse catch

When On-condition time of input signal is shorter than 1 scan time (Min. 50μs), Pulse catch processes the input signal as normal input.

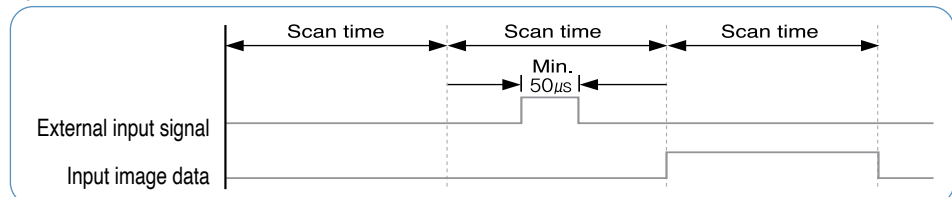

Item	Description			
	Block type unit			Modular type
	H	SU	E	S
Pulse catch	10μs: 4 points (P00000~P00003)	10μs: 2 points (P00000~P00001)	50μs: 4 points (P00000~P00003)	50μs: 8 points (P00000~P00007)
	50μs: 4 points (P00004~P00007)	50μs: 6 points (P00002~P00007)		

Input filter

Input filter prevents processing of the input signal that is shorter than the filtering time. (Filtering time is set by parameter) In the application site where noise is frequently generated, input filter prevents wrong input caused by noise.

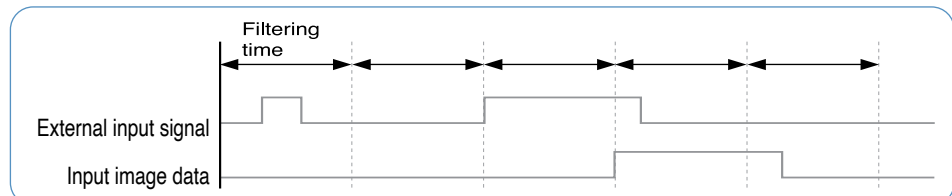

Classification	Description			
	Block type unit			Modular type
	H	SU	E	S
No. of setting points	Every input contact			
Input filtering time setting	Assigning for each module			
Setting range	1 ~ 100ms (1, 3, 5, 10, 20, 70, 100)			

I/O specifications | Block type unit

Task

Task function is the processing method of internal/external signal generated periodically or aperiodically. It stops operation of scan program for the moment and then execute the assigned task.

Classification	Description			
	Block type unit			Modular type
	H	SU	E	S
Initial task	1(_INT)			
Cyclic task	8			
I/O task	8	8	4	8
Internal device task	8			
External interrupt	10 μ s: 4 points (P00000~P00003) 50 μ s: 4 points (P00004~P00007)	10 μ s: 2 points (P00000~P00001) 50 μ s: 6 points (P00002~P00007)	50 μ s: 4 points (P00000~P00003)	50 μ s: 8 points (P00000~P00007)

RTC

RTC function is for time management of system and error log. RTC function is executed steadily when power is off or instantaneous power cut status. Current time of RTC is renewed every scan by system operation status information flag.

Classification	Description			
	Block type unit			Modular type
	H	SU	E	S
RTC	Built-in	Option module	Option module	Not available

Specification



Specification	Model	XBE-DC08A	XBE-DC16A	XBE-DC32A
Input point		8 points	16 points	32 points
Rated input voltage/current		DC 24V / 4mA		
Operation voltage range		DC 20.4 ~ 28.8V (Ripple rate < 5%)		
Input resistance		5.6kΩ		
Response time	Off → On	1 / 3 / 5 / 10 / 20 / 70 / 100ms (setting by CPU parameter) Initial value: 3ms		
	On → Off			
Insulation pressure		AC 560Vrms / 3 Cycle (altitude 2000m)		
Insulation resistance		10MΩ or more by megger		
COMMON method		8 points / COM	16 points / COM	32 points / COM
Internal current consumption		30mA	40mA	50mA

Wiring

[XBE-DC08A/DC16A]

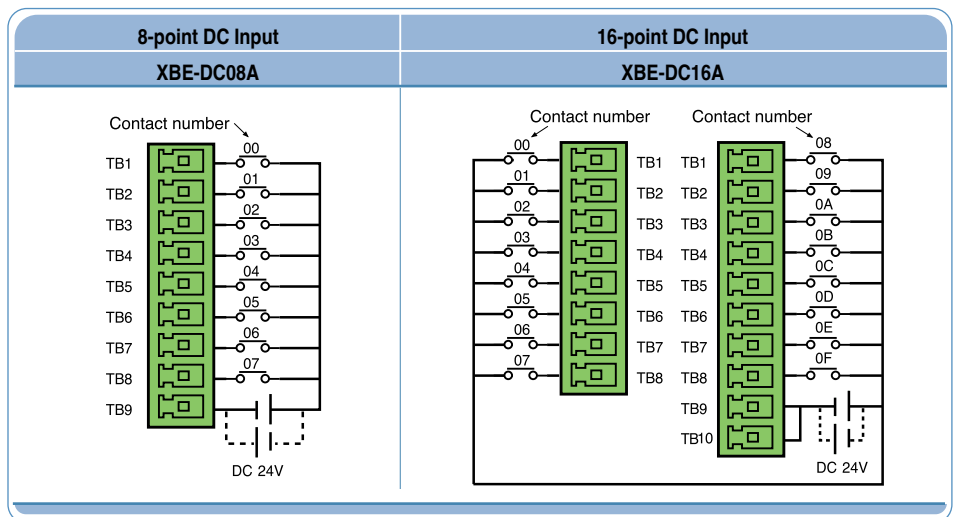

Specification

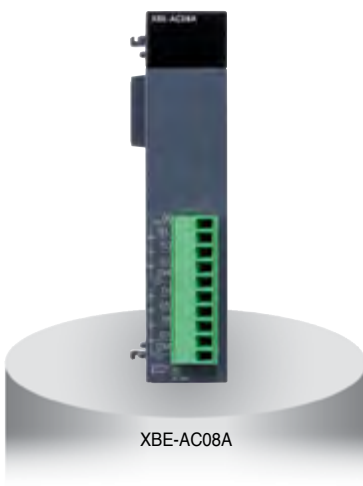

Specification	Model	XBE-AC08A
Input point		8 point
Insulation method		Photo coupler insulation
Rated input voltage		AC100-120V(+10/-15%) 50/60B(±3Hz) (distortion rate < 5%)
Rated input current		Max. 12mA / point
Inrush current		Max. 200mA 1ms (AC132V)
On Voltage/Current		AC80V or higher / 5 mA or higher (50Hz, 60Hz)
Off Voltage/Current		AC30V or lower / 1 mA or lower (50Hz, 60Hz)
Input resistance		About 12kΩ(60Hz), About 15kΩ(50Hz)
Response time	Off → On	20 ms or less (AC100V 50Hz, 60Hz)
	On → Off	25 ms or less (AC100V 50Hz, 60Hz)
Insulation pressure		AC3000Vrms / 3Cycle (altitude 2000m)
Insulation resistance		10MΩ or more by Megohmmeter
Common method		4 point / COM
Weight		70 g

Specification



Specification	Model	XBE-TN08A	XBE-TP08A	XBE-TN16A	XBE-TP16A	XBE-TN32A	XBE-TP32A
Type		Sink	Source	Sink	Source	Sink	Source
Output point		8 point		16 point		32 point	
Rated load voltage		DC 12 / 24V					
Load voltage range		DC 10.2 ~ 26.4 V					
Max. load current		0.2A / 1point		0.2A / 1point, 2A / COM			
Off leakage current		0.1mA or less					
Max. voltage drop (On)		DC 0.4V					
Response time	Off → On	1mA or less					
	On → Off	1mA or less (Rated load, resistive load)					
Common method		8 points / COM		16 points / COM		32 points / COM	
Internal current consumption		40mA		60mA		120mA	
External power supply	Voltage	DC 12 / 24V ± 10% (Ripple voltage ≤ 4 Vp-p)					
	Current	10mA or less (DC 24V connection)				20mA or less (DC 24V connection)	

Item		XBF-AD04C	
Analog range	Item	Voltage	Current
	Range	DC 1 ~ 5V, DC 0 ~ 5V, DC 0 ~ 10V, DC -10 ~ 10V (Input resistance 1MΩmin)	DC 4 ~ 20mA DC 0 ~ 20mA (Input resistance 250MΩ)
Digital Output Range	Type	16bit binary data (Data : 14bit)	
	Unsigned value	0 ~ 16000	
	Signed value	-8000 ~ 8000	
	Precise value	1000 ~ 5000 (1 ~ 5V), 0 ~ 5000 (0 ~ 5V), 0 ~ 10000 (0 ~ 10V)	4000 ~ 20000 (4 ~ 20mA), 0 ~ 20000 (0 ~ 20mA)
	Percentile value	0 ~ 10000	
Resolution		1/16000	
		0.250mV (1 ~ 5V) 0.3125mV(0 ~ 5V) 0.625mV (0 ~ 10V) 1.250mV(±10V)	1.0μA (4 ~ 20mA) 1.25μA (0 ~ 20mA)
Max. conversion speed		1ms/channel	
Max. absolute input		DC ±15V	DC ±3mA
Analog Input Channels		4 channel/module	
Insulation method		Photo-coupler insulation between input terminal and PLC power (no insulation between channels)	
Connection terminal		15-point terminal block	
Occupied I/O points		Fixed type : 64points	
Current consumption	DC 5V	110mA	
	DC 24V	100mA	

Wiring

[XBE-TN08A/TN16A]

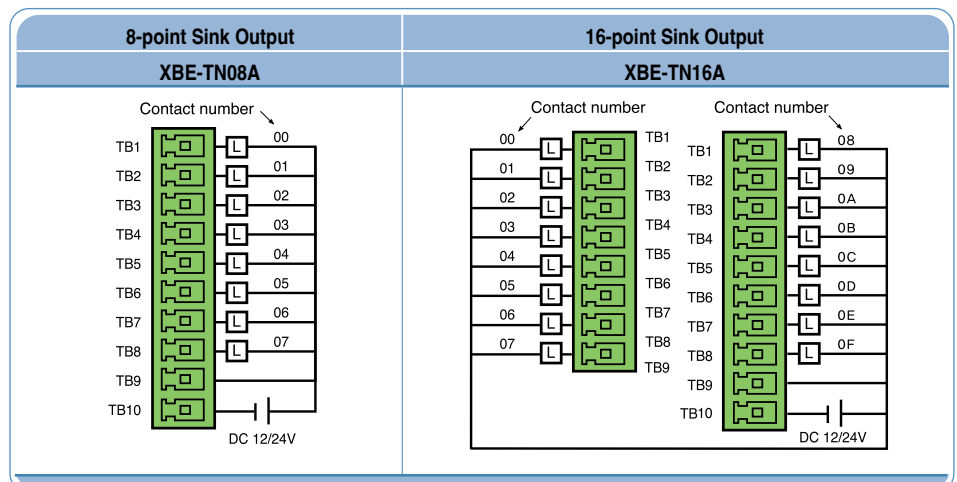

APPLICATION

Specification

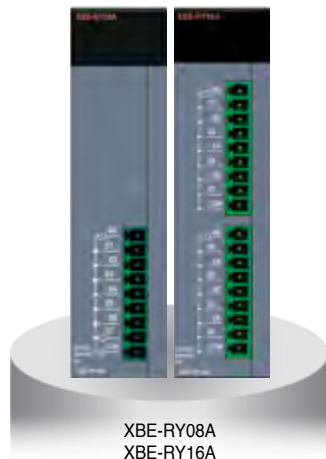

XBE-RY08A
XBE-RY16A

Model		XBE-RY08A	XBE-RY16A
Specification			
Output point		8 points	16 points
Insulation method		Relay insulation	
Rated input voltage/Current		DC 24V 2A (resistive load)/AC 220V 2A (COS Ψ = 1), 5A /COM	
Min. load voltage/Current		DC 5V 1mA	
Max. load voltage		AC 250V, DC 125V	
Off leakage current		0.1mA (AC 220V, 60Hz)	
Max. on/Off frequency		3,600 times / hr	
Surge absorber		None	
Service life	Mechanical	20million times or more	
	Electrical	Rated load voltage/Current 100,000 times or more	
		AC 200V/1.5A, AC 240V/1A (COS Ψ = 0.7) 100,000 times or more	
		AC 200V/1A, AC 240V/0.5 (COS Ψ = 0.35) 100,000 tiems or more	
Response time	Off \rightarrow On	10ms or less	
	On \rightarrow Off	12ms or less	
COMMON method		8 points / 1COM	
Internal current consumption		230mA	420mA
Operation indicator		Output On, LED On	
External connection method		9-pin terminal block connector	9-pin terminal block connector \times 2

Item		XBF-DV04C	XBF-DC04C
Analog range	Item	Voltage	
	Range	DC 1 ~ 5V, DC 0 ~ 5V, DC 0 ~ 10V, DC -10 ~ 10V (Input resistance 1k Ω or more)	DC 4 ~ 20mA DC 0 ~ 20mA (Input resistance 600M Ω or less)
Digital Output	Type	16bit binary data (Data : 14bit)	
	Unsigned value	0 ~ 16000	
	Signed value	-8000 ~ 8000	
	Precise value	1000 ~ 5000 (1 ~ 5V), 0 ~ 5000 (0 ~ 5V), 0 ~ 10000 (0 ~ 10V)	4000 ~ 20000 (4 ~ 20mA), 0 ~ 20000 (0 ~ 20mA)
Resolution	Percentile value	0 ~ 10000 1/16000	
		0.250mV (1 ~ 5V) 0.3125mV (0 ~ 5V) 0.625m V(0 ~ 10V) 1.250mV (\pm 10V)	1.0 μ A (4 ~ 20mA) 1.25 μ A (0 ~ 20mA)
Max. conversion speed		1ms/channel	
Analog Input Channels		4 channel/module	
Insulation method		Photo-coupler insulation between output terminal and PLC power (no insulation between channels)	
Connection terminal		11-point terminal block	
Occupied I/O points		Fixed type : 64points	
Current consumption	DC 5V	75mA	
	DC 24V	170mA	

DC Input specification

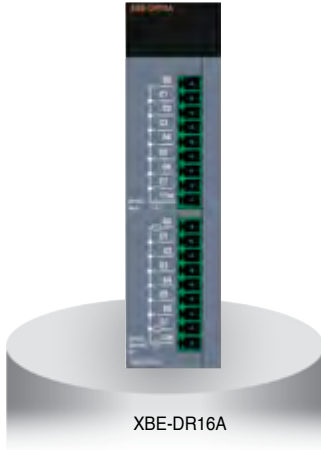

Model		DC Input (XBE-DR16A)
Specification		
Input point		8 points
Insulation method		Photocoupler
Rated input voltage		DC 24V
Rated input current		4mA
Operation voltage range		DC 20.4 ~ 28.8V (Ripple rate < 5%)
On voltage/On current		DC 19V or more/3mA or more
Off voltage/Off current		DC 6V or less/1mA or less
Input resistance		5.6kΩ
Response time	Off → On	1/3/5/10/20/70/100ms (setting by CPU parameter) init value: 3ms
	On → Off	
COMMON method		8 points/COM
Weight		81g

Relay output specification

Model		Relay Output (XBE-DR16A)
Specification		
Output point		8 points
Insulation method		Relay insulation
Rated input voltage/Current		DC 24V 2A (resistive load)/AC 220V 2A (COSΨ = 1), 5A /COM
Min. load voltage/Current		DC 5V 1mA
Max. load voltage		AC 250V, DC 125V
Off leakage current		0.1mA (AC 220V, 60Hz)
Max. on/Off frequency		3,600 times/hr
Surge absorber		None
Service life	Mechanical	20million times or more
	Electrical	Rated load voltage/Current 100,000 times or more
		AC 200V/1.5A, AC 240V/1A (COSΨ = 0.7) 100,000 times or more
		AC 200V/1A, AC 240V/0.5 (COSΨ = 0.35) 100,000 tiems or more
Response time	Off → On	10ms or less
	On → Off	12ms or less
COMMON method		8 points/1COM
Internal current consumption		250mA
Operation indicator		Output On, LED On
External connection method		9-pin terminal block connector

Wiring (XBE-DR16A)

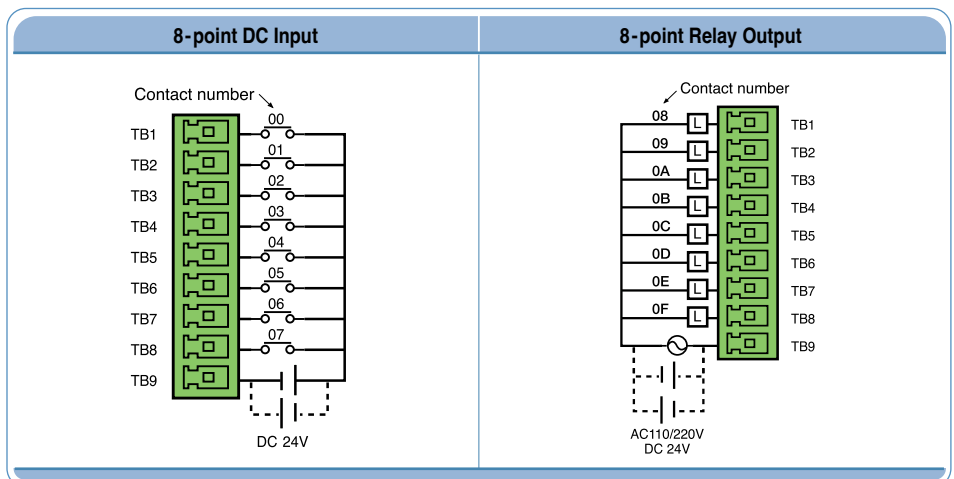

DC Input specification

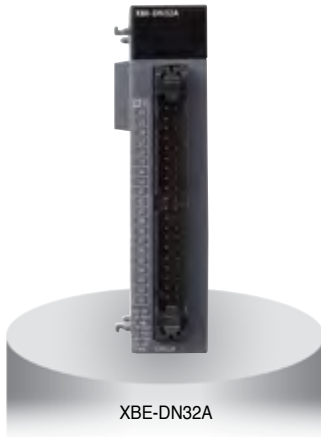

XBE-DN32A

Model		DC input module
Specification		XBE-DN32A
Input point		16 point
Insulation method		Photo coupler insulation
Rated input voltage		DC24V
Rated input current		About 4mA
Input Derating		DC20.4~28.8V (ripple rate < 5%)
Operation voltage range		Refer to Derating diagram
On voltage / On current		DC 19V or higher / 3 mA or higher
Off voltage / Off current		DC 6V or less / 1mA or less
Input resistance		About 5.6kΩ
Response time	Off → On	1/3/5/10/20/70/100ms (set by CPU parameter) Default:3ms
	On → Off	
Insulation pressure		AC 560Vrms / 3 Cycle (altitude 2000m)
Insulation resistance		10MΩ or more by Megohmmeter
Common method		16 point / COM
Proper cable size		0.3mm ²
Current consumption		60mA (When all inputs and outputs are on)
Operation indicator		Input On, LED On
External connection method		40 pin connector
Weight		60g

Transistor specification

Model		Main unit
Specification		XBE-DN32A
Output point		16 point
Insulation method		Photo coupler insulation
Rated voltage		DC12/24V
Rated current		About 4mA
Operation voltage range		DC10.2~26.4V
Max. load voltage		0.2A / 1 point, 2A / 1COM
Off leakage current		0.1mA or less
Max. load voltage		0.7A / 10ms or less
Max. voltage drop (On)		DC 0.4V or less
Surge absorber		TVS Diode
Response time	Off → On	1ms or less 1ms or less (Rated load, resistive load)
	On → Off	
Common method		32 point / COM
Proper cable size		0.3mm ²
Current consumption		60mA (when all point On)
External power	Voltage	DC12/24V 10% (ripple voltage 4 Vp-p or less) 20mA or less (connecting DC24V)
	Current	
Operation indicator		LED On when output On
External connection method		40 pin terminal block connector
Weight		60g

Wiring

(XBE-DN32A)

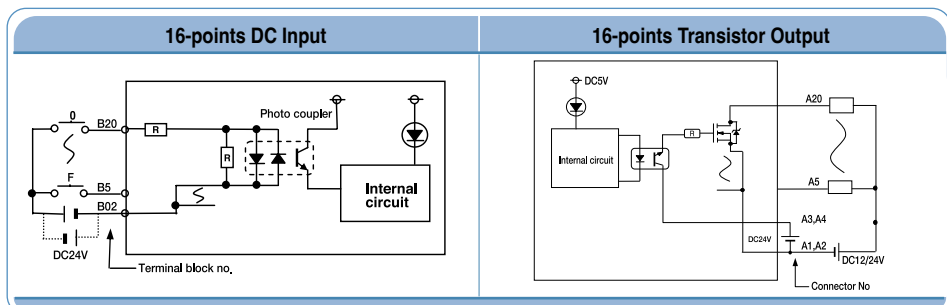

Specification

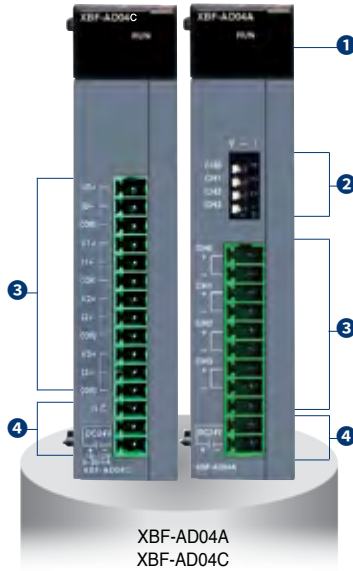

Item		XBF-AD04A		XBF-AD04C		XBF-AD08A	
Analog range	Item	Voltage	Current	Voltage	Current	Voltage	Current
	Range	DC 0~10V (input resistance : 1MΩ min.)	DC 4~20mA, DC 0~20mA (input resistance : 250Ω)	DC 1 ~ 5V DC 0 ~ 5V DC 0 ~ 10V DC -10 ~ 10V (Input resistance : 1MΩ min)	DC 4 ~ 20mA DC 0 ~ 20mA (Input resistance : 250MΩ)	DC 1~5V DC 0~5V DC 0~10V (Input resistance : 250MΩ)	DC 4~20mA, DC 0~20mA (input resistance : 250Ω)
Digital output	Type	12bit binary data		16bit binary data (Data : 14bit)		12bit binary data	
	Range	Unsigned value		0 ~ 4000		0 ~ 4000	
		Signed value		-2000~2000		-2000~2000	
	Precise value	0~1000	4000~2000/ 0~2000	100~5000 (1~5V) 0~5000 (0~5V) 0~10000 (0~5V) -10000~10000(±10V)	4000~20000 (4~20mA) 0~20000 (0~20mA)	100~500 (DC 1~5V) 0~500 (DC 0~5V) 0~1000 (DC 0~10V)	4000~2000 (DC 4~20mA) 0~2000 (DC 0~20mA)
Percentile value		0~1000		0~10000		0~1000	
Resolution		2.5mV (1/4000)	5μA (1/4000)	1/16000 0.250mV (1~5V) 0.3125mV (0~5V) 0.625mV (0~10V) 1.250mV (±10V)		125mV (DC 1~5V, 0~5V) 2.5mV (DC 0~10V)	5μA (DC 4~20mA, 0~20mA)
Max. conversion speed		1.5ms / channel		1ms / channel		1.5ms / channel	
Max. absolute input		±15V	±25mA	DC±15V	DC±3mA	±15V	±25mA
Analog Input channels		4 channel/module		4 channel/module		8 channel/module	
Insulation method		Photocoupler insulation between I/O terminal and power supply		Photo-coupler insulation between input terminal and PLC power (No insulation between channels)		Photocoupler insulation between I/O terminal and power supply	
Connection terminal		11-point terminal block		15-point terminal block		11-point terminal block	
Occupied I/O points		Fixed type : 64 points					
Current consumption	DC 5V	120mA		110mA		105mA	
	DC 24V	62mA		100mA		85mA	

Names and Functions

No.	Name	Descriptions
①	RUN LED	<ul style="list-style-type: none"> ▶ Indicates condition of module • LED On: Normal condition • LED On and Off: Flickering • LED Off: Power Off or module malfunction
②	Input selection S/W	<ul style="list-style-type: none"> ▶ Voltage/Current selection switch • V: Voltage input selection • I: Current input selection
③	Terminal block	▶ External device connection
④	External power supply terminal	▶ External DC 24V input

Wiring

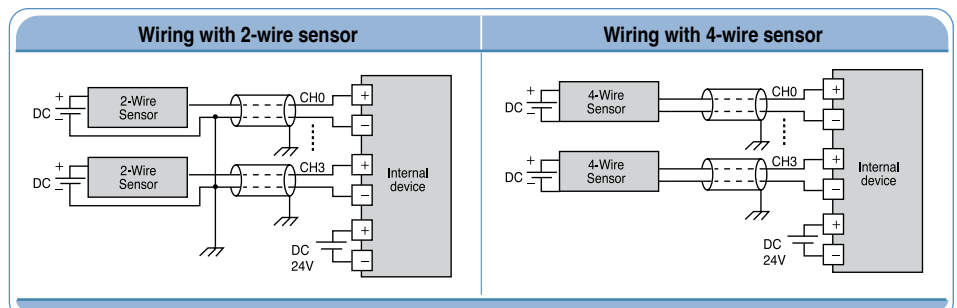

※ Use 22AWG, 2 conductor, twist shielded cable when wiring between analog module and external device.

APPLICATION

Specification

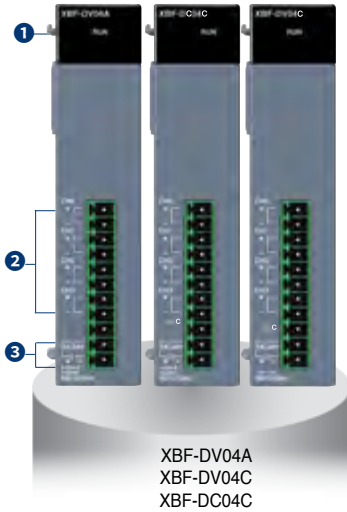

Item	XBF-DV04A	XBF-DV04C	XBF-DC04C	XBF-DC04A
Analog range	DC 0 ~ 10 V (Load resistance $\geq 2k\Omega$)	DC 1 ~ 5V DC 0 ~ 5V DC 0 ~ 10V DC -10 ~ 10V (Input resistance : 1k Ω or more)	DC 4 ~ 20mA DC 0 ~ 20mA (Input resistance : 600M Ω or less)	4 ~ 20mA / 0 ~ 20mA (Load resistance $\leq 510\Omega$)
Analog range Selection	-	-	-	XG 5000 I/O parameter
Output range	0 ~ 10 V	-	-	4 ~ 20mA/0 ~ 20mA
Unsigned value	0 ~ 4000	-	-	0 ~ 4000
Signed value	-2000 ~ 2000	-	-	-2000 ~ 2000
Digital data				
Precise value	0 ~ 1000	1000~5000 (1~5V) 0~5000 (0~5V) 0~10000 (0~10V) -1000~10000 ($\pm 10V$)	4000~20000 (4~20mA) 0~20000 (0~20mA)	400 ~ 2000/0 ~ 2000
Percentile value	0~1000	-	-	0~1000
Data format	Data format of digital input is set by user program or I/O parameter (Setting for each channel is available.)			
Resolution	Resolution (1/4000) 2.5mV	1/1600 0.250m (1~5V) 0.3125m (0~5V) 0.625m (0~10V) 1.250m ($\pm 10V$)	1.0 μ A (4~20mA) 1.25 μ A (0~20mA)	Resolution (1/4000) 5 μ A
Max. conversion speed	1ms/channel	1ms/channel	1ms/channel	1ms/channel
Max. absolute output	$\pm 15V$	-	-	$\pm 25mA$
Accuracy	$\pm 0.5\%$ or less	-	-	$\pm 0.5\%$ or less
Analog output channels	4 channel/module	4 channel/module	4 channel/module	4 channel/module
Insulation method	Photocoupler insulation between I/O terminal and power supply	Photo-coupler insulation between output terminal and PLC power (no insulation between channels)	-	Photocoupler insulation between I/O terminal and power supply
Connection terminal	11-point terminal block			
Occupied I/O points	Fixed type: 64 points			
Current consumption	DC 5V	110mA	75mA	110mA
	DC 24V	70mA	170mA	120mA

Names and Functions

No.	Name	Descriptions
1	RUN LED	<ul style="list-style-type: none"> ▶ Indicates condition of module • LED On: Normal condition • LED On and Off: Flickering • LED Off: Power Off or module malfunction
2	Terminal block	▶ External device connection
3	External power supply terminal	▶ External DC 24V input

Wiring

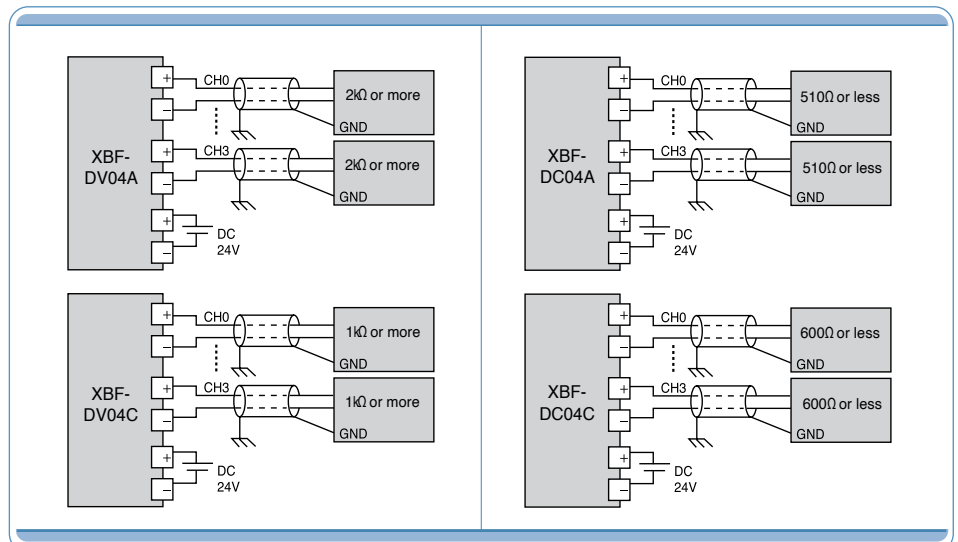

Specification

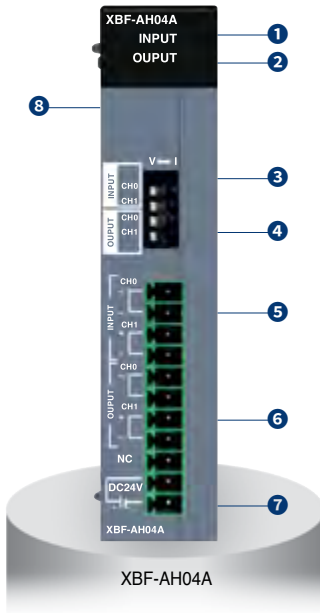

Item	XBF-AH04A	
	Input	Output
Analog channel	2 channels	2 channels
Analog range	DC 1 ~ 5V, DC 0 ~ 5V, DC 0 ~ 10V (Input resistance: 1 MΩ min.) DC 4 ~ 20mA, DC 0 ~ 20mA (Input resistance 250Ω)	DC 1 ~ 5V, DC 0 ~ 5V, DC 0 ~ 10V (Load resistance ≥ 2kΩ) DC 4 ~ 20mA, DC 0 ~ 20mA (Load resistance ≤ 510Ω)
Analog range selection	XG 5000 I/O parameter and External switch	
Digital data	Unsigned value	0 ~ 4000
	Signed value	-2000 ~ 2000
	Precise value	100 ~ 500 (DC 1 ~ 5V), 0 ~ 500 (DC 0 ~ 5V), 0 ~ 1000 (DC 0 ~ 10V) 400 ~ 2000 (DC 4 ~ 20mA), 0 ~ 2000 (DC 0 ~ 20mA)
	Percentile value	0 ~ 1000
Resolution (1/4000)	1.25mV (DC 1~5V, 0~5V), 2.5mV (DC 0~10V) 5μA (DC 4~20mA, 0~20mA)	
Max. conversion speed	±15V, 25mA	
Max. absolute output	1ms / Channel	
Accuracy	±0.5% or less	
Insulation method	Photocoupler insulation between I/O terminal and power supply	
Connection terminal	11-point terminal block	
Occupied I/O points	Fixed type: 64 points	
Current consumption	DC 5V	120mA
	DC 24V	130mA

Names and Functions

No.	Name	Descriptions
1	INPUT LED	<ul style="list-style-type: none"> ▶ Indicates input condition of module • LED On: Normal condition • LED On and Off: Flickering • LED Off: Power Off or module malfunction
2	OUTPUT LED	<ul style="list-style-type: none"> ▶ Indicates output condition of module • LED On: Normal condition • LED On and Off: Flickering • LED Off: Power Off or module malfunction
3	Input selection S/W	▶ Voltage / Current selection switch for input
4	Output selection S/W	▶ Voltage / Current selection switch for output
5	Terminal block	▶ Terminal for external input device
6		▶ Terminal for external output device
7	External power supply terminal	▶ Terminal for external DC 24V input
8	Expansion connector	▶ Terminal for expansion

Wiring

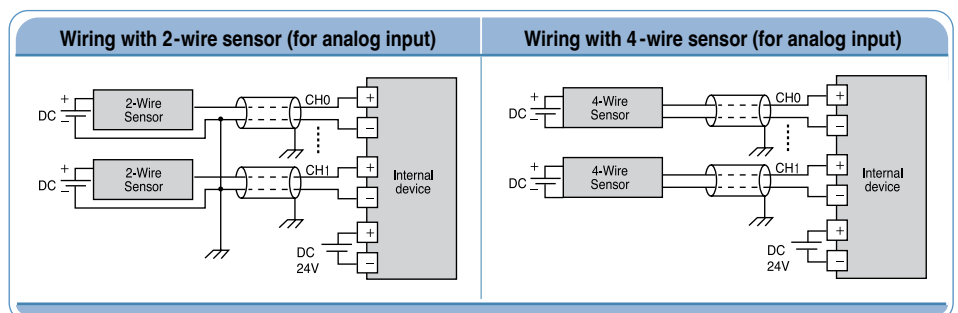

※Use 22AWG, 2 conductor, twist shielded cable when wiring between analog module and external device.

APPLICATION

Specification

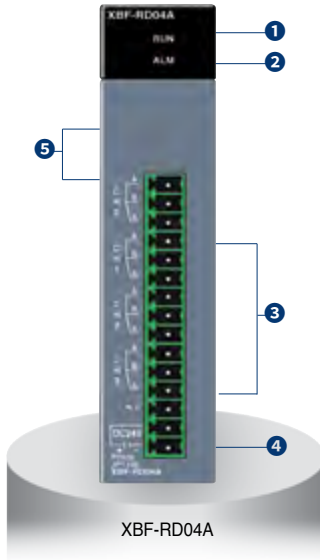

Item	XBF-RD04A	
Number of channels	4	
Sensor type	PT 100	JIS C1804-1997
	JPT 100	JIS C1604-1981, KS C1603-1991
Temperature range	PT 100	-200 ~ 600°C
	JPT 100	-200 ~ 600°C
Digital output	PT 100	-2000 ~ 6000
	JPT 100	-2000 ~ 6000
	Scaling	0 ~ 4000
Accuracy	25°C	±0.3% or less
	0 ~ 55°C	±0.5% or less
Conversion speed	40ms / Ch	
Wiring method	3-wire	
Current consumption	DC 5V	100mA
	DC 24V	100mA

Names and Functions

No.	Name	Descriptions
1	RUN LED	<ul style="list-style-type: none"> ▶ Displays the hardware operation status (Fatal fault) • On: Normal status • Flickering: Error (0.2s flickering) • Off: hardware error or power off
2	ALM LED	<ul style="list-style-type: none"> ▶ Displays the status of the channels (Light fault) • Flickering: Line disconnection (1s flickering) • Off: Normal status
3	Terminal block	▶ 3-wire RTD sensors can be connected
4	External power terminal	▶ Supplies the external DC 24V
5	Expansion connector	▶ Connects the module with an expansion module

Wiring

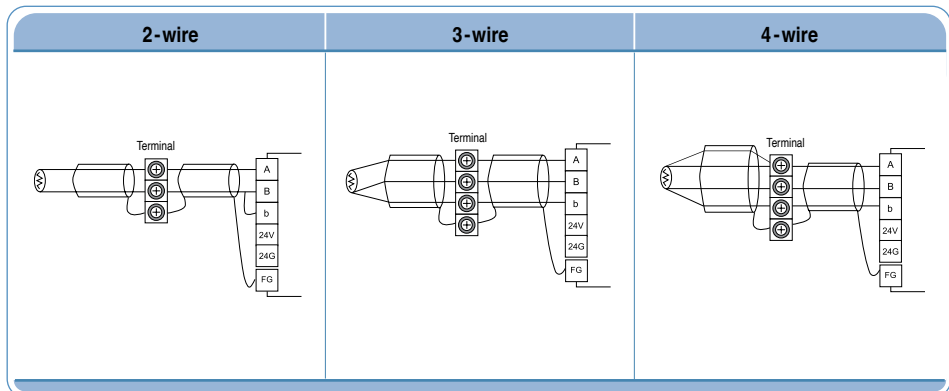

Specification

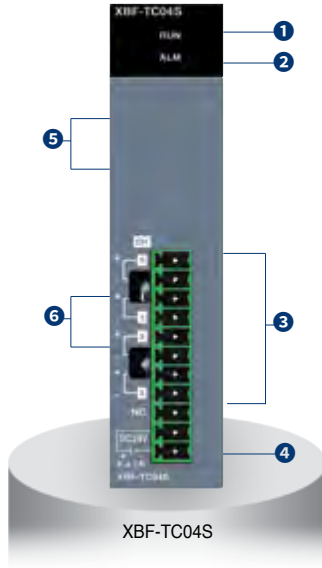

Item		XBF-TC04S
Number of channels		4
Input sensor type		Thermocouple K/J/T/R JIS C1602-1995
Temperature input range	K	-200.0°C ~ 1300.0°C (-328.0°F ~ 2372.0°F)
	J	-200.0°C ~ 1200.0°C (-328.0°F ~ 2192.0°F)
	T	-200.0°C ~ 400.0°C (-328.0°F ~ 752.0°F)
	R	0.0°C ~ 1700.0°C (32.0°F ~ 3092.0°F)
Digital output	Temperature display unit	Display down to one decimal place K, J, T: 0.1°C R: 0.5°C
	Scaling display (Defined by user)	Unsigned scaling (0 ~ 65535) Signed scaling (-32768 ~ 32767)
Accuracy	Normal temperature (25°C)	±0.2%
	Temperature coefficient (0 ~ 55°C)	±100 ppm / °C
Max. conversion speed		50ms / Channel
Warming-up time		15 minutes or more
Terminal		11-point terminal
I/O points occupied		64 points
Current consumption	DC 5V	100mA
	DC 24V	100mA

Names and Functions

No.	Name	Descriptions
1	RUN LED	▶ Displays the hardware operation status (Fatal fault) • On: Normal status • Flickering: Error (0.2s flickering) • Off: hardware error or power off
2	ALM LED	▶ Displays the status of the channels (Light fault) • Flickering: Line disconnection (1s flickering) • Off: Normal status
3	Terminal block	▶ Terminals to connect the thermo-couple sensor
4	External power terminal	▶ Terminals to supply the external DC 24V
6	RJC	▶ Device for Reference Junction Compensation

Wiring

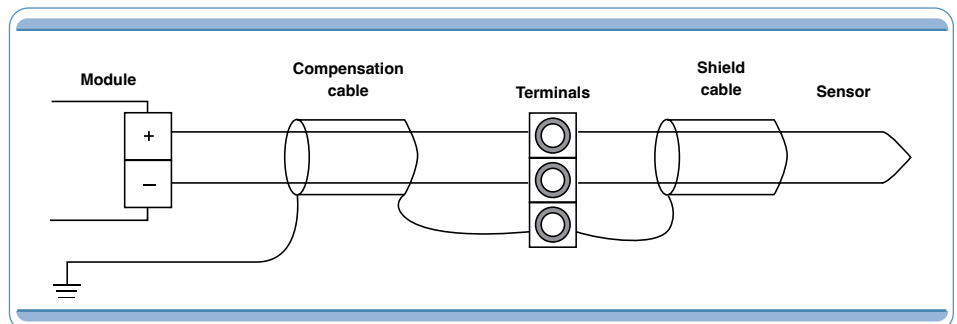

APPLICATION

Specification

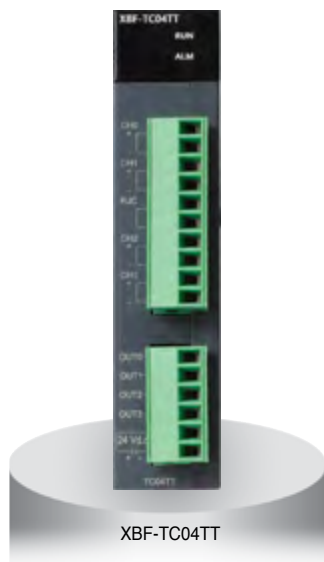

XBF-TC04TT

Item		XBF-TC04TT		
Control loop		4 loop		
Thermocouple type and input range	K	-200.0 ~ 1300.0 °C		
		0.0 ~ 500.0 °C		
	J	-200.0 ~ 1200.0 °C		
		0.0 ~ 500.0 °C		
T		-200.0 ~ 800 °C		
Precision	Standard precision	±0.2% or less (25 °C, normal temperature, except -200~-100 °C for the T type)		
	Temperature coefficient	±100ppm/°C(0.01%/°C)		
Cold junction compensation	Compensation method	Automatic compensation by RJC sensing		
	Compensation degree	±2.0 °C		
Sampling period		500ms/ 4 loop		
Control method		PID CONTROL, ON/OFF CONTROL		
Control parameter	Target value (SV)	Setting within range according to input type (temperature unit setting)		
	Proportional gain	0: ON/OFF CONTROL, REAL		
	Integral time	0: Except integral control, REAL		
	Derivative time	0: Except derivative control, REAL		
Transistor output	Output point	4		
	Rated load voltage	DC 24 V		
	Max. load current	0.1 A / Output point		
	Max. voltage drop when on	DC 1.2 V or less		
	Leakage current when off	0.1 mA or less		
	Response time	On ⇒ Off	1 ms or less	
		Off ⇒ On	1 ms or less	
Control output cycle	0.5 ~ 120.0 sec (Setting unit: 0.5 sec.)			
Time proportional resolution	Larger one of either 10 ms or 0.05% of the full-scale			
Insulation	Between input channels	Photo relay	Withstanding voltage: 400V AC, 50/60Hz 1min, leakage current 10mA or less	
	Input terminal-PLC power	Photo relay	Insulation resistor: 500V DC, 10 MΩ or above	
	Output terminal-PLC power	Non-insulation		
	Between output channels			
Averaging function	Weighted average	0 ~ 99% (setting range)		
	Moving average	0 ~ 99 times (setting range)		
Warm-up		20 minutes or above		
Maximum rate of ambient temperature changing		0.5 °C/min (30 °C/hour) or less		
Access terminal		16 point terminal (10 point terminal 1ea, 6 point terminal 1ea)		
IO occupation point		Fixed: 64 points		
Max. no. of installation		XBM-DxxxS type: 7ea, XB(E)C-DxxxH type: 10ea, XB(E)C-DxxxSU: 7ea, XB(E)C-DxxxU: 10ea		
Power supply		5 V, DC 24 V		
Current consumed		Internal DC 5 V : 120 mA, External DC 24 V : 100 mA		

Specification

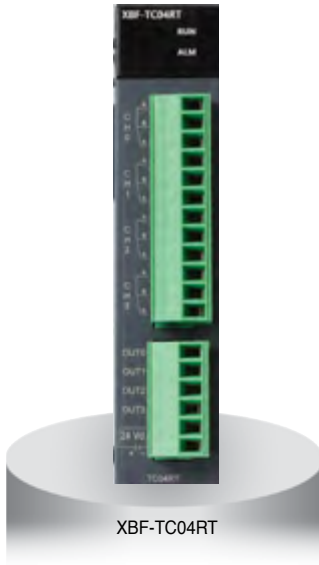

XBF-TC04RT

Item		XBF-TC04RT		
Control loop		4 loop		
RTD type and input range	Pt100	-200.0 ~ 850.0 °C		
	JPt100	-200.0 ~ 600.0 °C		
Precision	Standard precision	±0.2% or less (25 °C, normal temperature)		
	Temperature coefficient	±100ppm/ °C(0.01%/ °C)		
Sampling period		500ms/ 4 loop		
Control method		PID CONTROL, ON/OFF CONTROL		
Control parameter	Target value (SV)	Setting within range according to input type (temperature unit setting)		
	Proportional gain	0: ON/OFF CONTROL, REAL		
	Integral time	0: Except integral control, REAL		
	Derivative time	0: Except derivative control, REAL		
Transistor output	Output point	4		
	Rated load voltage	DC 24 V		
	Max. load current	0.1 A/Output point		
	Max. voltage drop when on	DC 1.2 V or less		
	Leakage current when off	0.1 mA or less		
	Response time	On ⇒ Off	1 ms or less	
		Off ⇒ On	1 ms or less	
	Control output cycle	0.5 ~ 120.0 sec (Setting unit: 0.5 sec.)		
Time proportional resolution	Larger one of either 10 ms or 0.05% of the full-scale			
Insulation	Between input channels	Photo relay	Withstanding voltage: 1500V AC, 50/60Hz 1min, leakage current 10mA or less	
	Input terminal- PLC power	Photo relay	Insulation resistor: 500V DC, 10 MΩ or above	
	Output terminal- PLC power Between output channels	Non-insulation		
Averaging function	Weighted average	0 ~ 99% (setting range)		
	Moving average	0 ~ 99 times (setting range)		
Access terminal		18 point terminal (12 point terminal 1ea, 6 point terminal 1ea)		
IO occupation point		Fixed: 64 points		
Max. no. of installation		XBM-DxxxS type: 7ea, XB(E)C-DxxxH type: 10ea, XB(E)C-DxxxSU: 7ea, XB(E)C-DxxxU: 10ea		
Power supply		5 V, DC 24 V		
Current consumed		Internal DC 5 V : 120 mA, External DC 24 V : 100 mA		

Specification

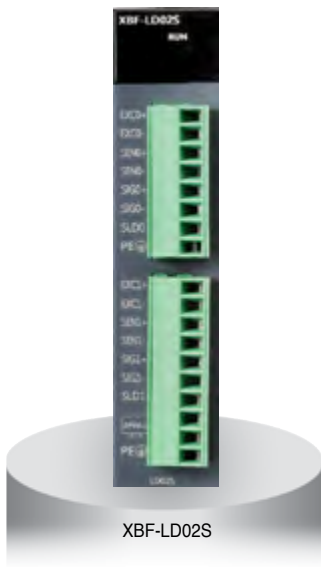

XBF-LD02S

Item	Specifications			
Input Channel	2 Channel (Insulation between Channels)			
Load Cell Input Voltage	5VDC $\pm 5\%$, (8 per 350 Ω load cell channel)			
Load Cell Type	Four-wire or Six-wire			
Resolution	1/40000			
Analog Input Range	0.0~6.0mV			
Load Cell Output Sensitivity	0.125 μ V(when the rated output of the load cell is 0.0 ~ 1.0mV/ V)			
Input Accuracy	$\pm 0.01\%$ or below (nonlinear accuracy, 25°C) Zero Drift: $\pm 0.25^\circ\text{C}$, Gain Drift: $\pm 15\text{ppm}/^\circ\text{C}$			
Sampling Cycle (per channel)	5ms			
Insulation	Classification	Insulation Method	Insulation Voltage Resistance (Internal Test Specifications)	Insulation Resistance
	Input terminal-Internal circuits	Isolator	AC 550 V 50/60 Hz 1 minute, Leakage 10 mA or below	DC500 V, 10 M Ω or above
	Between input channels	Transformer		
External power-Internal circuits	DC/DC Converter			
Warm-up time	30 minutes or above			
Input Connector	8 pins Connector(CH0)/10 pins Connector(CH1)			
IO Occupation Points:	Fixed type:64 points			
Max. no. of installation	XBM-DxxxS type: 7ea, XB(E)C-DxxxH type: 10ea, XB(E)C-DxxxSU: 7ea, XB(E)C-DxxxU: 10ea,			
Power Supply	5V, DC 24			
Consumption	Internal DC5V : 110mA, External DC24V : 280mA			

Specification

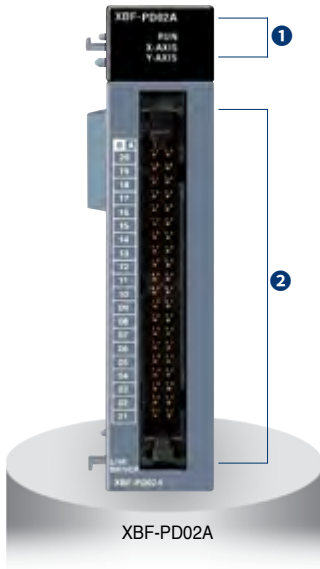

Item		XBF-PD02A
NO. of control axis		2 axis
Pulse output type		Line drive
Max. pulse output		2Mpps
Max. connection length		10m
Control mode		Position control, Speed control, Speed/Position switching control, Position/Speed switching control
Interpolation		Linear interpolation, Circular interpolation
Positioning data		150 operation data for each axis
Configuration tool		Built-in function parameter of XG5000
Back-up		Flash memory
Positioning	Positioning method	Absolute/Incremental method
	Unit	pulse
	Positioning range	-2,147,483,648 ~ 2,147,483,648
	Speed range	1~2,000,000 (pulse/sec)
	Acceleration/Deceleration type	Trapezoidal acceleration/deceleration
Acceleration/Deceleration time		0~65,535ms, Asymmetric acceleration/deceleration
Max. encoder input		200kpps (Line drive)
Error/Operation		LED
I/O occupied points		Fixed type: 64 points
Connection terminal		40pin connector
Current consumption (mA)		500

Names and Functions

No.	Name	Descriptions
1	RUN LED	1. RUN ▶ Displays the hardware operation status • On: Normal status • Off: Abnormal status 2. X_AXIS, Y_AXIS • On: Operation • Flickering: Error
2	Terminal block	▶ Terminals to connect the MPG, external device and drive device.

Terminal

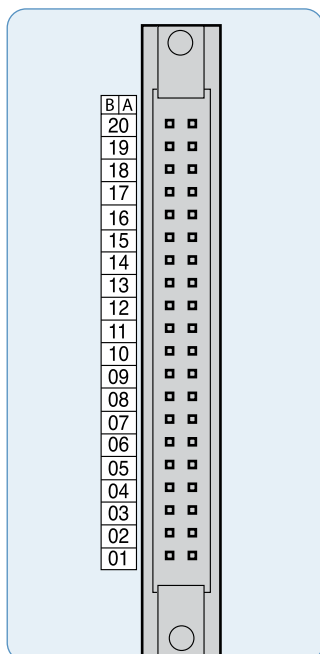

Pin number		Signal name	
X axis	Y axis		
	B20	MPG A+	Manual Pulse Generator/Encoder A+ input
	A20	MPG A-	Manual Pulse Generator/Encoder A- input
	B19	MPG B+	Manual Pulse Generator/Encoder B+ input
	A19	MPG B-	Manual Pulse Generator/Encoder B- input
A18	B18	FP+	Forward pulse+
A17	B17	FP-	Forward pulse-
A16	B16	RP+	Reverse pulse+
A15	B15	RP-	Reverse pulse-
A14	B14	OV+	High limit
A13	B13	OV-	Low limit
A12	B12	DOG	Near point
A11	B11	NC	-
A10	B10		
A09	B09	COM	Common
A08	B08	NC	-
A07	B07	INP	Inposition signal
A06	B06	INP COM	Inposition signal common
A05	B05	CLR	Deviation counter clear signal
A04	B04	CLR COM	Deviation counter clear signal common
A03	B03	HOME +5V	Zero signal (DC 5V)
A02	B02	HOME COM	Zero signal Common
A01	B01	NC	-

APPLICATION

Specification

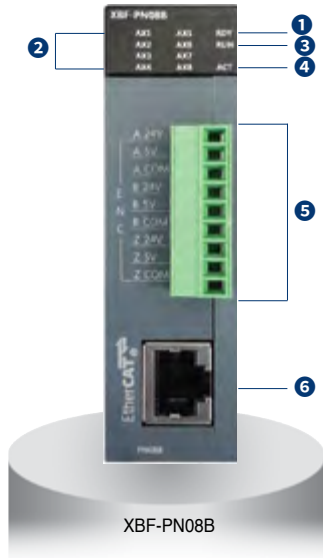

Item		XBF-PN08B			
No. of control axis		8			
Interpolation function		2~8 axes linear interpolation, 2 axes circular interpolation, 3 axes helical interpolation			
Control method		Position control, Speed control, Speed/Position control, Position/Speed control, Position/Torque Control, Feed control			
Control unit		Pulse, mm, inch, degree			
Positioning data		Each axis can have up to 400 operation data. (Operation step number : 1~400) Available to set with XG-PM or program			
XG-PM	Connection	RS-232C port of CPU module or USB			
	Setting data	Common, Basic, Extended, Servo parameter, Operation data, Cam data, Command information			
	Monitor	Operation information, Trace, Input terminal information, Error information			
Back-up		Save the parameter, operation data in MRAM ROM (No need of Battery)			
Positioning	Positioning method	Absolute method/Incremental method			
	Position address range		Absolute	Incremental	Speed/Position, Position/Speed Switching control
		mm	-214748364.8~-214748364.7(μm)	-214748364.8~-214748364.7(μm)	-214748364.8~-214748364.7(μm)
		Inch	-21474.83648~-21474.83647	-21474.83648~-21474.83647	-21474.83648~-21474.83647
		degree	-21474.83648~-21474.83647	-21474.83648~-21474.83647	-21474.83648~-21474.83647
	pulse	-2147483648~-2147483647	-2147483648~-2147483647	-2147483648~-2147483647	
	Speed range	mm	0.01~20000000.00(BAE/min)		
		Inch	0.001~2000000.000(Inch/min)		
		degree	0.001~2000000.000(degree/min)		
		pulse	1~20,000,000(pulse/SEC)		
rpm	0.1~100000.0(RPM)				
Acc./Dec. process	Trapezoid type, S-type				
Acc./Dec. time	1~2,147,483,647ms selection is available from 4 types of acceleration/deceleration pattern				
Manual Operation		Jog Operation, MPG Operation, Inching Operation			
Homing method		Refer to the method supported by the servo driver			
Speed change function		Speed change (Percent/Absolute value)			
Torque unit		Rated torque % designation			
Absolute position system		Available (when using absolute encoder type servo driver)			
External Encoder input	Channel	1 channel			
	Max. Input	200 kpps			
	Input form	Line drive input (RS-422A IEC specification), open collector output type encoder			
	Input type	CW/CCW, PULSE/DIR, Phase A/B			
Connection connector	9-point connector				
Communication Period		1ms			
Max. transmission distance		100m			
Communication cable		Over CAT.5 STP (Shielded Twisted-pair) cable			
Error indication		Indicated by LED			
Communication status indication		Indicated by LED			
Consumable current		510mA			
Weight		115g			

Names and Functions

No.	Name	Descriptions
1	Module ready signal	On: Positioning module normal status Off: Power OFF or CPU module reset status Flicker: Positioning module abnormal status
2	Operation indicator LED (AX1 ~ AX8)	On: applicable axis is running Off: applicable axis is stop status Flicker: applicable axis is error status
3	Communication status indicator LED	On: communication with servo driver is connected Off: communication with servo driver is disconnected Flicker: Error occurs during communicating with servo driver
4	TRX status LED	On: Wiring with servo driver is done Off: Wiring with servo driver is not done Flicker: communicating with servo driver
5	Connector for encoder wiring	Connector to connect with encoder
6	RJ-45 connector	RJ-45 connector to connect with servo driver

Terminal

Pin arrangement	Pin No.	Signal name	Signal direction
A 24V	1	Encoder A 24V input	Input
A 5V	2	Encoder A 5V input	
A COM	3	Encoder A input COM	
B 24V	4	Encoder B 24V input	
B 5V	5	Encoder B 5V input	
B COM	6	Encoder B input COM	
Z 24V	7	Encoder Z 24V input	
Z 5V	8	Encoder Z 5V input	
Z COM	9	Encoder Z input COM	

Specification

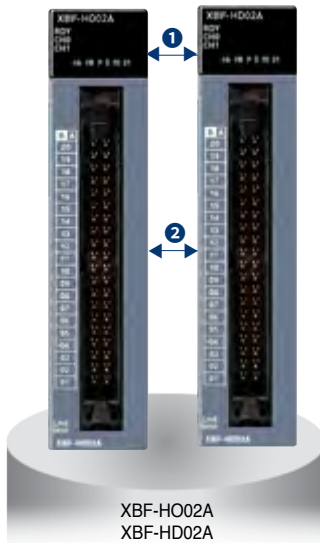

Item		Specification	
		XBF-HD02A	XGF-HD02A
Count input signal	Signal	A-phase, B-phase	
	Input type	Voltage input (Open Collector)	Differential input (Line Drive):
	Signal level	DC 5/12/24V	RS-422A Line Drive/HTL LEVEL Line Drive
Maximum coefficient speed		200kpps	500kpps (HTL input : 250kpps)
Number of channels		2 Channels	
Coefficient range		Signed 32-bit (-2,147,483,648 ~ 2,147,483,647)	
Count mode		Linear Count (When 32-bit range exceeded, Carry/Borrow occurs, The count value stopped)	
		Ring Count (Repeated count within setting range)	
Input pulse mode		1-phase input	
		2-phase input	
		CW/CCW input	
Up/down setting	1-phase input	Increasing/Decreasing operation setting by B-phase input	
	2-phase input	Increasing/Decreasing operation setting by program	
	CW/CCW	Automatic setting by difference in phase	
Multiplication function	1-phase input	A-phase input: Increasing operation	
	2-phase input	B-phase input: Decreasing operation	
	CW/CCW	1/2 multiplication	
Control input	Signal	Preset instruction input, Auxiliary mode instruction input	
	Signal level	DC 5V/12V/24V (by terminal selection) input type	
	Signal type	Voltage	
External output	Output points	2-point/channel (for each channel): Terminal output available	
	Type	Select single-compared (>, >=, =, <=, <) or section compared output (Included or excluded)	
	Output type	Open collector output (Sink)	
Operation status display	Input signal	A-phase input, B-phase input, Preset instruction input, Auxiliary mode instruction input	
	Output signal	External output 0, External output 1	
	Busy status	Module Ready	
Count enable		To be set through program (Count available only in enable status)	
Preset function		To be set through terminal or program	
Auxiliary mode function		Count clear, Count latch, Section count(time setting value: 0~60000ms), Measurement of input frequency(for respective input phase), Measurement of counts per hour(time setting value: 0~60000ms) Count prohibited function	
Terminal		40 pin connector	
I/O occupied points		Fixed point: 64	
Current consumption(mA)		200	260
Weight		90g	

Names and Functions

No.	Name	Descriptions
①	Run LED (ØA, ØB, P, G, 00, 01)	<ul style="list-style-type: none"> ▶ On: Relevant channel pulse inputting, Preset/Auxiliary function signal inputting, Outputting ▶ Off: No input of relevant channel pulse, No input of preset/ Auxiliary function signal, No output of comparison
	Ready signal (RDY)	<ul style="list-style-type: none"> ▶ On: HSC module normal ▶ Off: Power off or CPU module reset, HSC module error • Flicker: HSC module error
②	External wiring connector	Connector to connect with external I/O

Terminal (XBF-H002A)

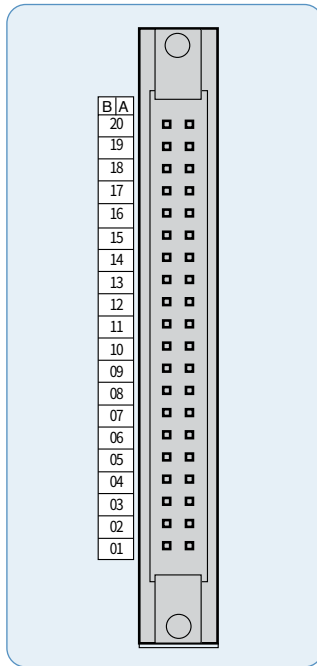

Pin arrangement		Signal name	
B ch1	A ch0		
20	20	A 24V	A phase pulse input 24V
19	19	A 12V	A phase pulse input 12V
18	18	A 5V	A phase pulse input 5V
17	17	A COM	A phase pulse input COM
16	16	B 24V	B phase pulse input 24V
15	15	B 12V	B phase pulse input 12V
14	14	B 5V	B phase pulse input 5V
13	13	B COM	B phase pulse input COM
12	12	P 24V	Preset input 24V
11	11	P 12V	Preset input 12V
10	10	P 5V	Preset input 5V
09	09	P COM	Preset input COM
08	08	G 24V	Auxiliary function input 24V
07	07	G 12V	Auxiliary function input 12V
06	06	G 5V	Auxiliary function input 5V
05	05	G COM	Auxiliary function input COM
04	04	OUT0	Comparison output 0
03	03	OUT1	Comparison output 1
02	02	24V	External power input 24V
01	01	24G	External power input GND

Terminal (XBF-HD02A)

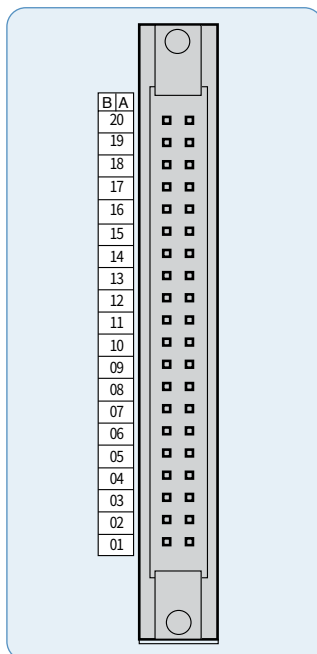

Pin arrangement		Signal name	
B ch1	A ch0		
20	20	A I +	A I phase differentiation input +
19	19	A I -	A I phase differentiation input -
18	18	A II +	A II phase differentiation input +
17	17	A II -	A II phase differentiation input -
16	16	B I +	B I phase differentiation input +
15	15	B I -	B I phase differentiation input -
14	14	B II +	B II phase differentiation input +
13	13	B II -	B II phase differentiation input -
12	12	P 24V	Preset input 24V
11	11	P 12V	Preset input 12V
10	10	P 5V	Preset input 5V
09	09	P COM	Preset input COM
08	08	G 24V	Auxiliary function input 24V
07	07	G 12V	Auxiliary function input 12V
06	06	G 5V	Auxiliary function input 5V
05	05	G COM	Auxiliary function input COM
04	04	OUT0	Comparison output 0
03	03	OUT1	Comparison output 1
02	02	24V	External power input 24V
01	01	24G	External power input GND

Ethernet (XBL-EMTA)

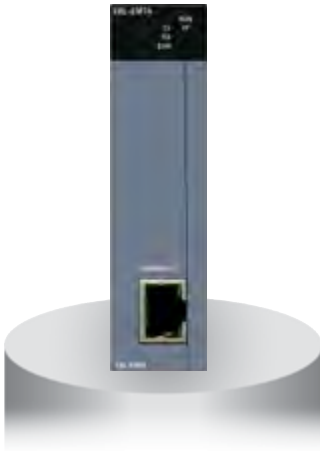

Item	XBL-EMTA	
Communication spec.	10/100 Base-TX	
Protocol	TCP/IP, UDP/IP	
Service	With LS PLCs	High-speed link, P2P service
	With other devices	P2P service
	Application	XGT Dedicated protocol Server/Client, Modbus/TCP Server/Client
HS link sending/Receiving data	200words/block (Max. 64blocks)	
No. of channel Connectable to upper stage	6 channels	
Service	Communication with PC (HMI) and external devices, High-speed communication among LS ELECTRIC PLCs	
Media	UTP/STP Category 5	
Current consumption (mA)	300	

RS-232C, RS-422 / 485



XBL-C21A
XBL-C41A

Item	Built-in RS-232C	XBL-C21A	Built-in RS-485	XBL-C41A
Interface	RS-232C 1ch	RS-232C 1ch	RS-485 1ch	RS-422 / 485 1ch
MODEM function	Remote communication via the external MODEM (XBL-C21A Only)			
Mode	Dedicated mode	1:1 or 1:N via the dedicated protocol		
	XG5000 mode	Program download, Upload and control via the remote control		
	P2P mode	Communication defined by the protocol using XG-PD XGT/Modbus master		
Operation mode	Server (slave)	XGT/Modbus server, User-defined communication		
	Client (master)	XGT/Modbus P2P Master, User-defined communication		
Data format	Start Bit	1		
	Data Bit	7 or 8		
	Stop Bit	1 or 2		
	Parity	Even / Odd / None		
	Setting	Setting by XG-PD parameter		
Synchronous	Asynchronous			
Speed (bps)	1,200/2,400/4,800/9,600/19,200/38,400/57,600/115,200 bps			
Station number	Setting by XG-PD, Max. 32 stations			
Distance	RS-232C: Max.15m (Expansion by MODEM), RS-422/485: Max 500m			
MODEM communication	-	Support	-	-
Network	1 : 1		1 : N	
Diagnostic	Via LED and XG-PD			
Max. expansion	Built-in	2 stages	Built-in	2 stages

RAPINet (XBL-EIMT)



Item	XBL-EIMT	
Transmission standard	Transmission speed	100Mbps
	Transmission method	Base band
	Max. extension distance between nodes	100m
	Max. number of nodes	64
	Max. protocol size	1,516 bytes
	Access method to service zone	CSMA / CD
	Frame error check	$CRC\ 32 = X^{32} + X^{26} + X^{23} + \dots + X^2 + X + 1$
	Normal communication guarantee	Max. 1,200 (packet/sec)
Basic standard	Dimension (mm)	90(H) x 27(W) x 60(D)
	Current consumption(mA)	290
	Weight (g)	102

Ethernet/IP (XBL-EIPT)



Item		XBL- EIPT
Transmission standard	Transmission speed	100Mbps
	Transmission method	Base band
	Max. extension distance between nodes	100m
	Access method to service zone	CSMA/CD
	Frame error check	$CRC\ 32 = X^{32} + X^{26} + X^{23} + \dots + X^2 + X + 1$
Topology		Line, Star
The number of connections (Client/Server)	TCP	16 / 32
	CIP (IO communication)	32 / 64
Number of Max. services (P2P)		2
Number of Max. installations		2
Max. setting data size per block	Periodic client	500 bytes
	Aperiodic client	512 bytes
Basic standard	Dimension (mm)	90(H) x 27(W) x 60(D)
	Current consumption(mA)	290
	Weight (g)	102

Profibus-DP Module
(XBL-PMEC, XBL-PSEA)



Item		XBL-PMEC	XBL-PSEA
Module Type		Slave	
Network Type		Profibus-DP	
Standard		EN501170/DIN19245	
Interface		RS-485 (Electric)	
Topology		Bus type	
Modulation Type		NRZ (Non Return to Zero)	
Protocol		Profibus DP-V0	
Max. Distance & Transmission Speed	Distance (m)	Send Speed (bps)	
		1,200	9.6k/19.2k/93.75k/187.5k
	400	500k	
	200	1.5M	
	100	3M/6M/12M	
Max. number of stations per segment		32 (including master & repeater)	
Cable used		Electric-twist shielded pair cable	
Max. Communication size		Input : 122 Word Output : 122 Word	
Max. Communication size per block		Input : 64 Word Output : 64 Word	
Communication Transmission cycle		10/20/50/100/200/500ms, 1/5/10s	
Communication Receive cycle		Main unit scan × 2 + Data receive time + Communication module scan	
Max. number of units installed		2 units	
Communication Parameters to set		XG5000 (setting station and high-speed link parameter block)	
Internal-consumed current (mA)		300	250
Weight (g)		86 (including connector: 122)	

DeviceNet Module (XBL-DSEA)



Item		XBL-DSEA	
Transmission Specification	Transmission Speed (kbps)	125/250/500	
	Transmission Type	Poll, Bit strobe, COS, Cyclic	
	Communication distance (m)	Thick Cable	500 (125kbps)/250 (250kbps)/100 (500kbps)
		Thin Cable	100 (125/250/500kbps)
	Terminal resistance (Ω)	121 (1%, 1/4W)	
	Max.drop length (m)	125 kbps	6 (Max. extended length 156)
		250 kbps	6 (Max. extended length 78)
		500 kbps	6 (Max. extended length 39)
	Data Packet	0~8 Bytes	
	Message Access Control	CSMA/NBA	
	Network Structure	<ul style="list-style-type: none"> • Trunk/drop line • Power/Signal cable inside the identical network cable 	
	Bus Type	• Poll type	
	Max. number of nodes	Up to 64 (including master) MAC IDs (MAC Identifier)	
	System Features	Insertion and removal of nod available in voltage On status	
Operation Voltage	DC 24V		
Diagnosis Function	Module: Checks duplicated station/ Checks CRC error SyCon: Detects defective station/Checks BusOff/Auto-scan function XG5000: Monitors High-speed link		
Master/Slave Operation	Available only in slave		
Parameter setting	Setting to High-speed link of XG5000 (RS-232C of CPU module or USB port)		
XG5000 (High-speed link) Specification	Data process unit	Word	
	Send/Receive period	Select among 10ms, 20ms, 50ms, 100ms, 200ms, 500ms, 1s, 5s and 10s - Default : 20ms	
	Max. communication point	Send 2048points, Receive 2048 points, 256 bytes respectively	
	Max. block number	64 (Setting range: 0~63)	
	Max. point number per block	1024 points (64 Words)	
Basic Specification	Max. modules installed	Up to 2	
	Internal-consumed current (mA)	100mA	
	Weight (g)	110	

Rnet (XBL-RMEA)



Item		XBL-RMEA
Transmission Speed		1Mbps(Rnet I/F modules common)
Max. Tx distance		Max. 750m
Connection Cable		Twisted pair shielded cable
Maximum stations connected	Network	Master station 1[station no:0(fixed)] + Slave stations up to 31[station no:1~63], Note 1) - Only 1 master is available in the network.
	Diagnostic function	XG5000 : High Speed Link Monitoring
Terminal resistance (Ω)		110 Ω ($\pm 5\%$), 1/2W
Master/Slave operation		Only available as Master
XG5000(HS Link)	Data Processing unit	Byte
	Tx/Rx cycle	Selection among 20ms, 50ms, 100ms, 200ms(default), 500ms, 1s, 5s, 10s
	Max. Communication points.	3,780 Bytes (slave 31stations * 120Bytes/station)
	Max. Block number	64 (setting range : 0~63)
	Max. points by Block	120 Byte (60words)
	Auto scanning	Supported
Specification	Max. module mounted	2 modules

CANopen Module (XBL-CMEA, XBL-CSEA)



Item	XBL-CMEA	XBL-CSEA
Transmission Speed	10, 20, 50, 100, 125, 250, 500, 800, 1000Kbps	
Num. of port	1	
Max. node	32	-
PDO	TPDO	64
	RPDO	64
Max. size of data per PDO	8Byte	
PDO transfer type	Synchronous acyclic (0), synchronous cyclic (1~240), RTR (252~253), time-event trigger (254~255)	
Support SDO	Client 127/Server 1	Server 1
SDO transfer type	Expedited, Normal	-
Access method	CSMA/BA (Carrier Sense Multiple Access/Bitwise Arbitration)	
Topology	BUS	
SYNC Service	Producer Cycle : 20~5000ms	Consumer
NMT. eode control	NMT master	NMT slave
Emergency	Save the last five per slave	Save up to last 10
NMT. error control	Heartbeat, Life guarding	Heartbeat
Network scan	○	
Size (mm)	90 (H)X27 (W)X60 (D)	
Current consumption (mA)	211	202
Weight (g)	78	

Option modules



Option modules

XBO-AD02A	Voltage/Current, Input 2 chs
XBO-DA02A	Voltage/Current, Output 2 chs
XBO-AH02A	Voltage/Current, Input 1 ch Voltage/Current, Output 1 ch
XBO-TC02A	TC (Thermocouple), Input 2 chs
XBO-RTCA	RTC (Real Time Clock)
XBO-DC04A	DC 24V, Input 4 points
XBO-TN04A	Transistor (Sink), Output 4 point
XBO-RD01A	RTD (Resistance Temperature Detect, Input 1 ch)

Smart link

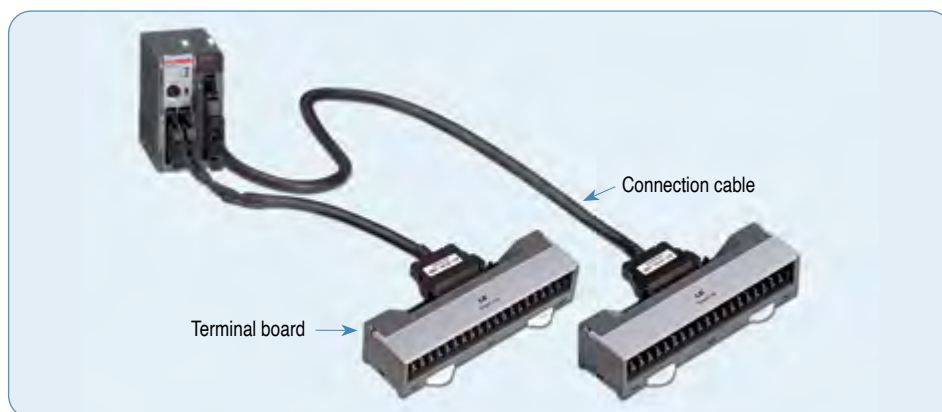

Connection cable	XBF-PD02A	XBF-HO02A	XBF-HD02A	XBE-DC32A	XBE-TN32A	XBE-TP32A	XBM-DN16S	XBM-DN32S	XBM-DN32H	XBM/XEM-DN32HP (H2)	XGB-UP
R40H/20HH-05S-XBM3	-	-	-	-	-	-	●	●	-	-	-
R40H/20HH-10S-XBM3	-	-	-	-	-	-	●	●	-	-	-
C40HH-05SB-XBI	●	●	●	●	●	●	-	-	●	●	●
C40HH-10SB-XBI	●	●	●	●	●	●	-	-	●	●	●
C40HH-15SB-XBI	●	●	●	●	●	●	-	-	●	●	●
C40HH-20SB-XBI	●	●	●	●	●	●	-	-	●	●	●
C40HH-30SB-XBI	●	●	●	●	●	●	-	-	●	●	●
C40HH-05SB-XBE	-	-	-	-	●	●	-	-	-	-	-
C40HH-10SB-XBE	-	-	-	-	●	●	-	-	-	-	-
C40HH-15SB-XBE	-	-	-	-	●	●	-	-	-	-	-
C40HH-20SB-XBE	-	-	-	-	●	●	-	-	-	-	-
C40HH-30SB-XBE	-	-	-	-	●	●	-	-	-	-	-
C40HH-05SB-XBE	-	-	-	-	●	-	-	-	-	-	-
C40HH-10SB-XBE	-	-	-	-	●	-	-	-	-	-	-
C40HH-15SB-XBE	-	-	-	-	●	-	-	-	-	-	-
C40HH-20SB-XBE	-	-	-	-	●	-	-	-	-	-	-
C40HH-30SB-XBE	-	-	-	-	●	-	-	-	-	-	-

XG5000

(Programming software)

- Program editing & Engineering software
- Windows-based easy operation
- Multi-PLC, Multi-programming support
- Various monitoring and diagnosis functions
- Vista 2000, XP (Limited use in Windows 98, ME)

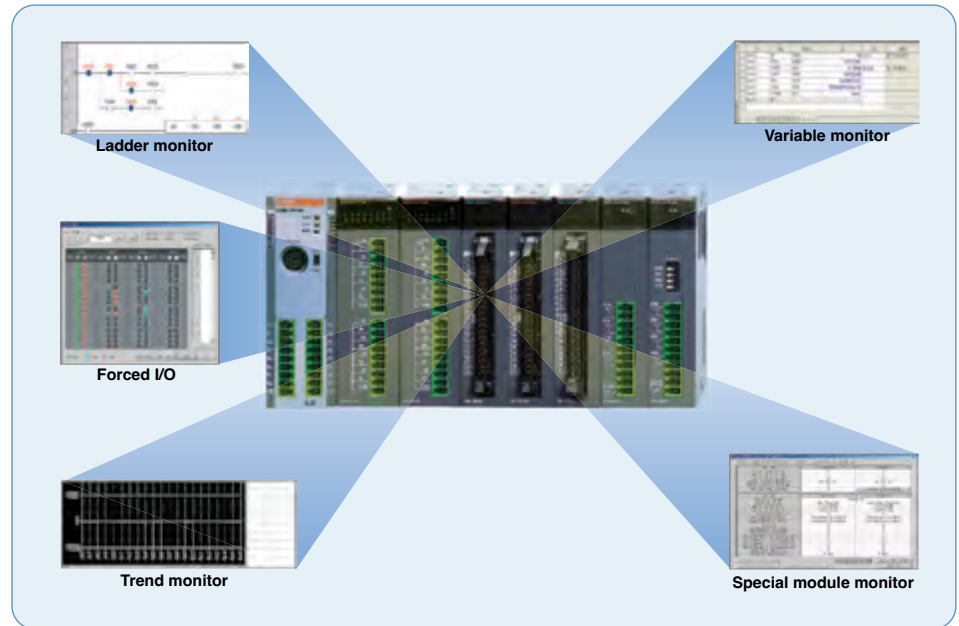

XG-PD

(Network setting software)

- Convenient network setting
- Extended monitoring function for network system and communication modules
- Fast interface with CPU by effective network management
- Various built-in diagnosis, functions
(CPU condition, Link condition, Service condition, Frame monitoring)

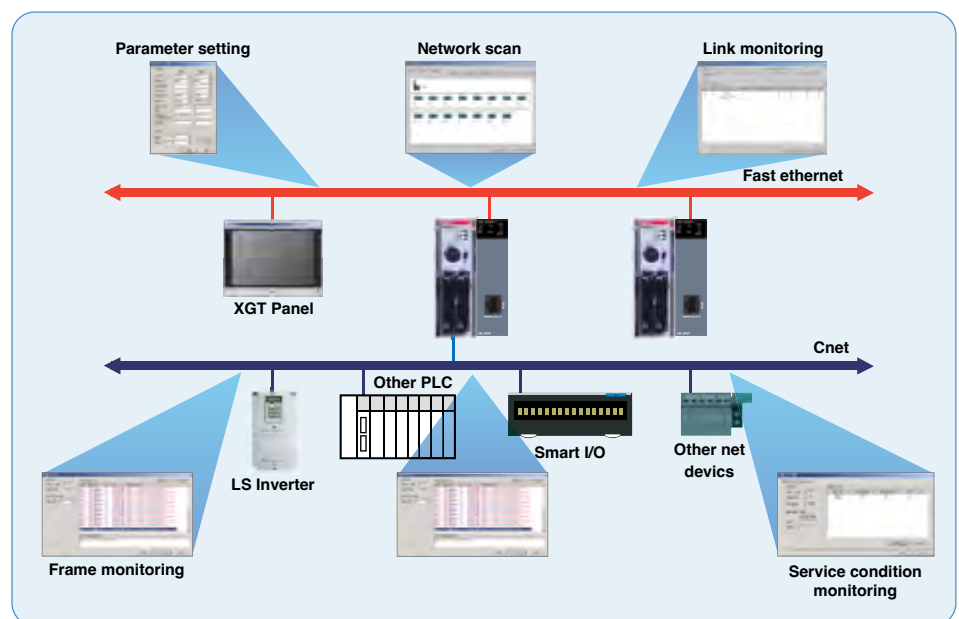

APPLICATION

Main Specification

- Aluminum body frame, responsive touch screen.
- Easy-to-use Multi-touch, gesture, dual screen, portrait mode.
- Multi connected with 1Gbits 2ch. Ethernet between PC to PLC.
- Various interfaces : USB host /device, SD card, HDMI.
- High resolution : 1024 X 768
- IP66, UL type 4x, NEMA 4x standards
- Explosion proof. IECEx, ATEX, KCs



Item	iXP2-0800A/D	iXP2-1000A/D	iXP2-1200A/D	iXP2-1500A/D
Display type	TFT color LCD			
Screen size	8.4"	10.4"	12.1"	15"
Display resolution	800×600	1,024×768		
Color indication	24-bit color (16.7M colors)			
Backlight	LED method, automatic On / Off support			
Backlight lifetime	40,000 hour			
Touch panel	Capacitive touch			
Audio output	Magnetic buzzer (85dB)			
Processor	1GHz, Dual core			
Memory	Flash	1GB		
	Operating RAM	1GB		
	Backup RAM	1 Mbyte		
Backup data	Date / Time data, Logging / Alarm / Recipe data, Non-volatile devices			
Battery	CR2032(3.0V/210mAh, About 3years/25°C)			
Video output	1 × HDMI			
Ethernet	1 × 10Base-T / 100Base-TX, 1 × 10Base-T / 100Base-TX / 1000Base-T			
USB host	3 x USB 2.0 (Front × 1, Rear x 2)			
USB device	1 × USB 2.0 (Send / Receive front, PC and project data etc.)			
RS-232C	1 × RS-232C (DSUB 9 / Male type)			
RS-422/485	1 × RS-422/485 (Terminal block)			
Multi-language	Can display 12 languages simultaneously			
Animation	GIF format support			
Recipe	Support			
Data logging	Support			
Script launcher	Support			
Standard certification	CE, KC, UL, IECEx, ATEX, KCs			
Protection standard	IP66, Conform to the UL type 4x, NEMA 4x standard			
Explosion proof	Ex nA IIC T5 Gc, Ex tc IIIC T100°C Dc IP64			
Dimensions (mm)	240 × 180 × 60	271 × 212 × 60	313 × 239 × 60	395 × 294 × 66
Panel cut (mm)	228.5 × 158.5	259.0 × 201.0	301.5 × 227.5	383.5 × 282.5
Power	iXP2-xxxxA : AC100 / 240V, iXP2-xxxxD : DC24V			
Power consumption (W)	25	25	30	30
Weight (Kg)	1.87	2.35	3.0	4.6

XGT Panel iXP Series

Programmable Logic Controller

Main Specification

- 1GHz 32bit RISC Embedded CPU
- 16,777,216 TFT color LCD
- 128MB display data and 1MB back-up memory
- Ethernet 1ch, RS-232C 2ch, RS-422/485 1ch
- USB host 3ch and device 1ch
- SD memory card interface

Main Functions

- PLC ladder monitoring (XGK/XBC PLC only)
- Web Server/Data Server
- Path through
- XP-Remote : Remote controlling and monitoring



Item	iXP50-TTA/DC	iXP70-TTA/DC iXP70-TTA/AC	iXP80-TTA/DC iXP80-TTA/AC	iXP90-TTA/DC iXP90-TTA/AC
Display type	TFT color LCD			
Screen size	21.3cm (8.4")	26.4cm (10.4")	30.7cm (12.1")	38.1cm (15")
Display Resolution	800×600 pixel(SVGA)	800×600 pixel(SVGA)	800×600 pixel(SVGA)	1,024×768 pixel(SVGA)
Color indication	16-bit and 24-bit Color (default: 16-bit Color)			
Indication degree	Left/Right: 80 deg. Up: 80 deg. Down: 60 deg.		Left/Right: 80 deg. Up: 60 deg. Down: 80 deg.	
Backlight	LED Type			
Backlight duration	70,000 hours	60,000 hours		
Brightness	500 cd/m ²	700 cd/m ²	550 cd/m ²	800 cd/m ²
Touch panel	4-Line type, analog			
Sound Output	Magnetic buzzer (85dB)			
Process	ARM Cortex-A8 Core (32bit RISC), 1GHz			
Memory	Flash	512MB(display 128MB)	1GB(display 128MB)	
	Operating RAM	256MB	512MB	
	Backup RAM	1MB		
Backup data	Date/Hour data, Logging/Alarm/Recipe data and nonvolatile device			
Battery duration	Approx. 3 years (Operating ambient temperature of 25°C)			
Ethernet	1 channel, 10/100BASE-TX			
USB Host	3 channels, USB 2.0 host (mouse, keyboard, printer* and USB memory driver is available) 1 channel, USB 2.0 slave (for download and upload project file)			
RS-232C	1 channel			
RS-422/485	1 channel, RS-422/485 mode			
SD Card	1 Slot (SDHC)			
Human sensor	-	Detection range: side 1-1.5m, front 40-50cm Angle: high/low 100°, left/right 140° (detecting 5-20 micron infrared light)		
Audio output	LINE-OUT 1 channel			
Expansion module	For communication and I/O option module (available later)			
VM module	-	4 channels video input (available later)		
Multi-language	Up to 12 language simultaneously			
Animation	GIF format is available			
Recipe	available			
Data logging	available			
Script executor	available			
Certifications	CE, UL(cUL), KC			
Protection standard	IP65			
Dimension (mm)	240.5×180.0×54.4	270.5×212.5×60.0	313.0×239.0×56.0	395.0×294.0×60.0
Panel cut (mm)	228.5×158.5	259.0×201.0	301.5×227.5	383.5×282.5
Rated voltage	DC24V		DC12/24V (AC 100-240V)	
Power consumption (W)	30.8	42.3	42.3	42.3
Weight(Kg)	1.9	2.2	2.4	3.9

TSEW00 printer only

APPLICATION

Fully compatible with eXP

- Panel cut, interface, design, and drawing file are 100% compatible.

Superior Performance

- ARM Cortex A8 800MHz, eMMC 4G, DDR3

Enhanced product reliability

- LCD Backlight lifespan extended
- Non Battery Type NVRAM

Variety of interfaces and functions

- Various communication drivers and Micro SD I/F available



Item	eXP2-04 □ *0D	eXP2-05 □ *0D	eXP2-05 □ *2D	eXP2-07 □ *0D	eXP2-07 □ *1D	eXP2-07 □ *2D	eXP2-10 □ *0D	eXP2-10 □ *1D	
Display Type	TFT Color LCD								
Screen Size	10.9cm [4.3"]	14.2cm [5.6"]		17.8cm [7"]			25.9cm [10.1"]		
Display Resolution	480 x 272	640 x 480		800 x 480			1024 x 600		
Color Indication	24Bit Color [16.7M]	18Bit Color [262,144]		24Bit Color [16.7M]			24Bit Color [16.7M]		
Indication Degree	Left/Right: 60 deg. Upper: 40 deg. Lower: 50 deg	Left/Right: 60 deg. Upper: 40 deg. Lower: 60 deg.		Left/Right: 70 deg. Upper: 50 deg. Lower: 70 deg.			Left/Right: 70 deg. Upper: 50 deg. Lower: 70 deg.		
Backlight	LED Type (Supports Backlight Auto-off Function)								
Backlight Duration	50,000 Hours	20,000 Hours		50,000 Hours			30,000 Hours		
Touch Panel	4-Wire Resistive, Analog								
Audio Output	Magnetic Buzzer (85dB)								
Process	800MHz	800MHz		800MHz			800MHz		
Memory	Drawing Memory	64MB	64MB		64MB			64MB	
	Operating RAM	512MB	512MB		512MB			512MB	
	Operating RAM	128KB	128KB		128KB			128KB	
Backup Data	Date/Hour Data, Logging/Alarm/Recipe Data and Nonvolatile Device								
Battery Life	Approx. 3 years (Operating Ambient Temperature of 50℃)								
Ethernet	1 Channel, IEEE802.1a, 10Base-T/100Base-TX		-	1 Channel, IEEE802.1a, 10Base-T/100Base-TX		-	1 Channel, IEEE802.1a, 10Base-T/100Base-TX		
USB Host	1 Channel, USB 2.0 Host (Mouse, keyboard, printer, USB flash drive, etc.)								
USB Device	-	1 Channel, USB 2.0 Device (for Download and Upload Project)					1 Channel, USB 2.0 Device (for Download and Upload Project File)		
Micro SD Card	-	-	-	1 Channel SDHC Class10		-	-	1 Channel SDHC Class10	
RS-485, RS-232C	1 Channel, RS-232C (DSUB 9/Male Type)			2 Channels, RS-485, RS-232C (DSUB 9/Male Type)					
RS-422/485	1 Channel, RS-422/485 (DSUB 9/Male Type)			1 Channel, RS-422/485 Mode (Terminal Type)					
Multi-language	Up to 12 Language Simultaneously								
Animation	GIF Format is Available								
Recipe	Available								
Data Logging	Available								
Script Executor	Available								
Certifications	CE, UL(cUL), UL Type 4X, KC		CE, UL(cUL), KC		CE, UL(cUL), UL Type 4X, KC		CE, UL(cUL), KC		
Protection Standard	IP65 ^{Note 1)}		IP65 ^{Note 1)}		IP65 ^{Note 1)}			IP65 ^{Note 1)}	
Dimension (mm)	128 x 102 x 32.5		165 x 132.5 x 36.1		208 x 154 x 44.4			276 x 218 x 35.1	
Panel Cut (mm)	119 x 93		156 x 123.5		192 x 138			260 x 202	
Rated Voltage	DC24V		DC24V		DC24V			DC24V	
Power Consumption (W)	4		5.5		6			6	
Weight (kg)	0.27		0.43		0.59		1.0		

□ *0 (WinCE 7.0 Core), 1 (WinCE 7.0 Pro)
 Note 1): IP66 for UL Type 4X models.

XGT Panel eXP Series

Programmable Logic Controller

Main Specification

- TFT LCD-applied wide type
- LED Backlight adopted for enhanced contrast ratio and low-power
- PLC Ladder monitoring function: Only XGK/XBC supports*
- Web Server* / Data Server* / Path-Through Function*
- Remote Viewer Function*
- Screen editor : XP-Builder

TFunctions that support only the TTA model



Item	eXP20-TTA/DC, CERTI	eXP20-TTA/DC	eXP30-TTA(B)/DC	eXP30-TTE/DC	eXP40-TTE/DC	eXP40-TTA(B)/DC	eXP40-TTA/DC, CERTI	eXP60-TTA(B)/DC	eXP60-TTA/DC, CERTI
Display type	TFT color LCD								
Screen size	10.9cm (4.3inch)		14.2cm(5.6inch)		17.8cm(7inch)		25.9cm(10.2inch)		
Display Resolution	480×272 pixel		640 x 480 pixel		600 x 800 pixel(WVAG)				
Color indication	24-bit Color(16.7M)		16-bit Color(65,536 Color)		24-bit Color(65,535 Color)			16-bit Color(65,536)	
Indication degree	Left/Right:60 deg. Upper:40 deg. Lower:60 deg.							Left/Right:55 deg. Upper:35 deg. Lower:55 deg.	
Backlight	LED Type (Supports backlight auto-off function)								
Backlight duration	30,000 hours			20,000 hours					
Touch panel	4-Wire Resistive, analog								
Audio output	Magnetic buzzer (85dB)								
Process	i.MX283(454MHz)								
Memory	Flash								
	128MB(Screen 64MB)								
	128MB								
Backup data	128KB								
	Date/Hour data, Logging/Alarm/Recipe data and nonvolatile device								
Battery duration	Approx. 3 years (Operating ambient temperature of 50°C)								
RTC	Time error Approx. 3 sec/1day(Operating ambient temperature of 25°C)								
Ethernet	1 channel, IEEE802.1a, 10Base-T/100Base-TX				-		1 channel, IEEE802.1a, 10Base-T/100Base-TX		
USB Host	1 channel, USB 2.0 Host (mouse, keyboard, printer and USB memory driver is available)								
USB Device	1 channel, USB 2.0 Device (for download and upload project)								
RS-485, RS-232C	1channel, RS-232C (DSUB 9/Male Type)				2channels, RS-485, RS-232C (DSUB 9/Male Type)				
RS-422/485	1channel, RS-422/485 (DSUB 9/Male Type)				1channel, RS-422/485 mode (Terminal Type)				
Multi-language	Up to 12 language simultaneously								
Animation	GIF format is available								
Recipe	available								
Data logging	available								
Script executor	available								
Certifications	CE, UL, KC, UL Type4X (Separate product, CERTI)								
Protection standard	IP66								
Dimension (mm)	128×102×32		165×132.5×36.1		208.0×154.0×44.4		276.0×218.0×44.4		
Panel cut (mm)	119×93		156.0×123.5		192.0×138.0		260.0×202.0		
Rated voltage	DC24V								
Power consumption (W)	4.6W		7.2W		6.5W		10W		
Weight(Kg)	0.3		0.42		0.39		0.62		0.63
									1.08

TSEW00 printer only

APPLICATION

Text type XP10

- Screen: 192×64 Graphic STN LCD
- System RAM: 1000 words
- Flash memory: Program/Parameter back up
- Communication: Half-duplex comm.
 - Baud rate: 1200~115200 bps
 - Master/slave setting available
 - RS-232C/RS-485 2 CH separate to use
- Power requirements - 24 V input or 5 V direct input by LS PLC
- Various function key - ESC, ALM, SET, ENT, F1~F4, Arrow keys
- Panel Editor - Easy programming and H/W setting

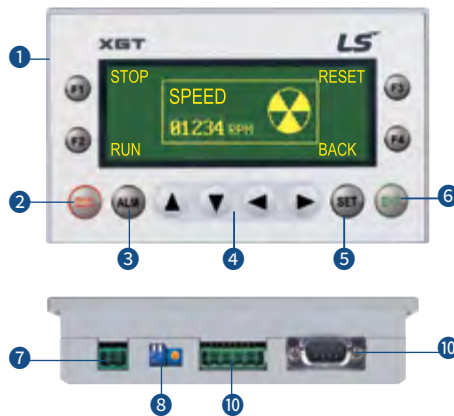

- 1 Key to control PLC device and screen
- 2 ESC key
- 3 Alarm history
- 4 Data input and Screen change
- 5 PLC data setting
- 6 Enter key
- 7 DC24V input terminal
- 8 RS-232C port to download a project
- 9 Brightness adjustment
- 10 RS-422 port

Item	Specifications	
	XP10BKA/DC	XP10BKB/DC
Input voltage	5VDC	DC 4.9 ~ 5.1 (RS-232C port)
	24VDC	DC 21.6 ~ 26.4 (DC Input connector)
	Consumption current	Less than 200mA
Display	LED back-light (192 x 64 Dots)	
Communication interface	RS-232C, RS-422/485	
Flash memory	256K bytes	
Language	Default: English, Can be switched to Korean/Chinese/Russian	
RTC	None	Supports
Download specification	115,200bps	
Keys	12 Keys (F1~F4, ESC, ALM, ▲, ▼, ◀, ▶, SET, ENT)	

Product list

Product list

Item	Model	Specifications	
Block type unit (U)	XBC/XEC-DN(P)32U	AC 110-220V, 16points DC24V input, 16points transistor sink(source) type output	
	XBC/XEC-DR28U	AC 110-220V, 16points DC24V input, 12points relay output	
	XBC/XEC-DN(P)32UP	AC 110-220V, 16points DC24V input, 16points transistor sink(source) type output, 4 axes built-in positioning	
	XBC/XEC-DR28UP	AC 110-220V, 16points DC24V input, 12points relay output, 4 axes built-in positioning	
	XBC/XEC-DN(P)32UA	AC 110-220V, DC24V input, 16points transistor sink(source) type output, 8 channel built-in analog	
	XBC/XEC-DR28UA	AC 110-220V, DC24V input, 12points relay output, 8 channel built-in analog	
	XBC/XEC-DN(P)32U/DC	DC 24V, 16points DC24V input, 16points transistor sink(source) type output	
	XBC/XEC-DR28U/DC	DC 24V, 16points DC24V input, 12points relay output	
	XBC/XEC-DN(P)32UP/DC	DC 24V, 16points DC24V input, 16points transistor sink(source) type output, 4 axes built-in positioning	
	XBC/XEC-DR28UP/DC	DC 24V, 16points DC24V input, 12points relay output, 4 axes built-in positioning	
	XBC/XEC-DN(P)32UA/DC	DC 24V, DC24V input, 16points transistor sink(source) type output, 8 channel built-in analog	
	XBC/XEC-DR28UA/DC	DC 24V, DC24V input, 12points relay output, 8 channel built-in analog	
Block type unit (High performance)	XBC/XEC-DR32H	AC 100 - 240V, DC24 input 16 points, relay output 16 points	
	XBC/XEC-DR64H	AC 100 - 240V, DC24 input 32 points, relay output 32 points	
	XBC/XEC-DN32H	AC 100 - 240V, DC24 input 16 points, transistor output 16 points (Sink)	
	XBC/XEC-DN64H	AC 100 - 240V, DC24 input 32 points, transistor output 32 points (Sink)	
	XEC-DP32H	AC 100 - 240V, DC24 input 16 points, transistor output 16 points (Source)	
	XEC-DP64H	AC 100 - 240V, DC24 input 32 points, transistor output 32 points (Source)	
	XBC-DR32H/DC	DC 24V, DC24 input 16 points, relay output 16 points	
	XBC-DR64H/DC	DC 24V, DC24 input 32 points, relay output 32 points	
	XBC-DN32H/DC	DC 24V, DC24 input 16 points, transistor output 16 points (Sink)	
	XBC-DN64H/DC	DC 24V, DC24 input 32 points, transistor output 32 points (Sink)	
Block type unit (Standard)	XBC/XEC-DR20SU	AC 100 - 240, DC24V input 12 points, relay output 8 points	
	XBC/XEC-DR30SU	AC 100 - 240, DC24V input 18 points, relay output 12 points	
	XBC/XEC-DR40SU	AC 100 - 240, DC24V input 24 points, relay output 16 points	
	XBC/XEC-DR60SU	AC 100 - 240, DC24V input 36 points, relay output 24 points	
	XBC/XEC-DN20SU	AC 100 - 240, DC24V input 12 points, transistor output 8 points (Sink)	
	XBC/XEC-DN30SU	AC 100 - 240, DC24V input 18 points, transistor output 12 points (Sink)	
	XBC/XEC-DN40SU	AC 100 - 240, DC24V input 24 points, transistor output 16 points (Sink)	
	XBC/XEC-DN60SU	AC 100 - 240, DC24V input 36 points, transistor output 24 points (Sink)	
	XBC/XEC-DP20SU	AC 100 - 240, DC24V input 12 points, transistor output 8 points (Source)	
	XBC/XEC-DP30SU	AC 100 - 240, DC24V input 18 points, transistor output 12 points (Source)	
	XBC/XEC-DP40SU	AC 100 - 240, DC24V input 24 points, transistor output 16 points (Source)	
	XBC/XEC-DP60SU	AC 100 - 240, DC24V input 36 points, transistor output 24 points (Source)	
	Block type unit (Economic)	XBC/XEC-DR10E	AC 100 - 240V, 6 points DC24V input, 4 point Relay ouput
		XBC/XEC-DR14E	AC 100 - 240V, 8 points DC24V input, 6 point Relay ouput
XBC/XEC-DR20E		AC 100 - 240V, 12 points DC24V input, 8 point Relay ouput	
XBC/XEC-DR30E		AC 100 - 240V, 18 points DC24V input, 12 point Relay ouput	
XBC/XEC-DN10E		AC 100 - 240V, 6 points DC24V input, 4 point transistor output (Sink)	
XBC/XEC-DN14E		AC 100 - 240V, 8 points DC24V input, 6 point transistor output (Sink)	
XBC/XEC-DN20E		AC 100 - 240V, 12 points DC24V input, 8 point transistor output (Sink)	
XBC/XEC-DN30E		AC 100 - 240V, 18 points DC24V input, 12 point transistor output (Sink)	
XBC/XEC-DP10E		AC 100 - 240V, 6 points DC24V input, 4 point transistor output (Source)	
XBC/XEC-DP14E		AC 100 - 240V, 8 points DC24V input, 6 point transistor output (Source)	
XBC/XEC-DP20E		AC 100 - 240V, 12 points DC24V input, 8 point transistor output (Source)	
XBC/XEC-DP30E		AC 100 - 240V, 18 points DC24V input, 12 point transistor output (Source)	
Modular type unit	XBM-DN32H	DC24V, 16 pts DC24V input, 16 pts TR output, 2 axes built-in positioning (APM)	
	XBM/XEM-DN32H2	DC24V, 16 pts DC24V input, 16 pts TR output, 2 axes built-in positioning (XPM)	
	XBM/XEM-DN32HP	DC24V, 16 pts DC24V input, 16 pts TR output, 6 axes built-in positioning (XPM)	
	XBM/XEM-DN16H2	DC24V, 8 pts DC24V input, 8 pts TR output, 2 axes built-in positioning (XPM)	
	XBM/XEM-DP32H2	DC24V, 16 pts DC24V input, 16 pts TR output(source), 2 axes built-in positioning (XPM)	
	XBM/XEM-DP32HP	DC24V, 16 pts DC24V input, 16 pts TR output(source), 6 axes built-in positioning (XPM)	
	XBM/XEM-DP16H2	DC24V, 8 pts DC24V input, 8 pts TR output(source), 2 axes built-in positioning (XPM)	
XBM/XEM-DR14H2	DC24V, 8 pts DC24V input, 6 pts relay output, 2 axes built-in positioning (XPM)		

APPLICATION

Product list

Item	Model	Specifications
Modular type unit	XBM-DR16S	DC 24V, 8-point DC24V input, 8-point relay output
	XBM-DN16S	DC 24V, 8-point DC24V input, 8-point TR output
	XBM-DN32S	DC 24V, 16-point DC24V input, 16-point TR output
Expansion I/O module	XBE-DC08A	8-point DC 24V input
	XBE-DC16A	16-point DC 24V input
	XBE-DC32A	32-point DC 24V input
	XBE-AC08A	8-point AC 110V input
	XBE-RY08A	8-point relay output
	XBE-RY16A	16-point relay output
	XBE-TN08A	8-point Transistor (sink) output
	XBE-TN16A	16-point Transistor (sink) output
	XBE-TN32A	32-point Transistor (sink) output
	XBE-TP08A	8-point Transistor (source) output
	XBE-TP16A	16-point Transistor (source) output
	XBE-TP32A	32-point Transistor (source) output
	XBE-DR16A	8-point DC 24V input, 8-point relay output
	XBE-DN32A	16-point DC24V input, 16point TR output
	XBF-AD04A	4-channel analog input (current/voltage)
	XBF-AD04C	4-channel analog input (current/voltage, resolution : 1/16000)
	XBF-AH04A	2-channel analog input (current/voltage)/2-channel analog output (current/voltage)
	Special module	XBF-DV04A
XBF-DV04C		4-channel analog input (voltage, resolution : 1/16000)
XBF-DC04A		4-channel analog output (current)
XBF-DC04C		4-channel analog input (current, resolution : 1/16000)
XBF-RD04A		4-channel RTD input
XBF-RD01A		1-channel RTD input
XBF-TC04S		4-channel Thermocouple input
XBF-TC04TT		Temperature controller, Thermocouple
XBF-TC04RT		Temperature controller, RTD
XBF-LD02S		Load Cell input module
XBF-PD02A		Line drive 2 axis
XBF-PN08B		EtherCAT Positioning module, 8axes (XBC/XEC "U" only)
XBF-PN04B		EtherCAT Positioning module, 4axes (XBC/XEC "U" only)
XBF-AD08A		8-channel analog input (Current/voltage)
XBF-HO02A		2-channel High-speed counter input (Open collector)
XBF-HD02A		2-channel High-speed counter input (Line drive)
XBL-C41A		Cnet (RS-422/485), 1ch
XBL-C21A		Cnet (RS-232C), 1ch
XBL-EMTA		Fast Ethernet (100Mbps), 1ch
Communication module		XBL-EIMT
	XBL-EIPT	Ethernet/IP, 2 ch
	XBL-EIMF	RAPINet I/F, Max. 2km (Fiber 2ch.), 100Mbps
	XBL-EIMH	RAPINet I/F (Twisted pair 1ch, Fiber 2 ch.), 100Mbps
	XBL-PMEC	Profibus-DP, Master, RS-485
	XBL-PSEA	Profibus-DP, Slave, RS-485
	XBL-DSEA	DeviceNet, Slave
	XBL-PSEA	Profibus-DP, Slave, RS-485
	XBL-RMEA	Rnet, Master
	XBL-CMEA	CANopen (10, 20, 50, 100, 125, 250, 500, 800, 1000Kbps, Num of PDO : 32)
	XBL-CSEA	CANopen (10, 20, 50, 100, 125, 250, 500, 800, 1000Kbps, Num of PDO : 64)

Product list

Item	Model	Specifications
Loader cable	PMC-310S	Connection cable (PC to PLC), 9pin(PC)-6pin(PLC)
	USB-301A	Connection cable (PC to PLC), USB
Memory module	XBO-M2MB	Memory
Option modules	XBO-AD02A	Voltage/Current, Input 2 ch
	XBO-DA02A	Voltage/Current, Output 2 ch
	XBO-AH02A	Voltage/Current, Input 1ch/Voltage/Current, Output 1ch
	XBO-TC02A	TC (Thermo couple), Input 2 ch
	XBO-RTCA	RTC (Real time clock), Battery
	XBO-DC04A	DC 24V, Input 4 points
	XBO-TN04A	TR (Sink), Output 4 points
	XBO-RD01A	RTD (Resistance temperature detector), Input 1 ch

Connection cable	XBF-PD02A	XBF-HO02A	XBF-HD02A	XBE-DC32A	XBE-TN32A	XBE-TP32A	XBM-DN16S	XBM-DN32S	XBM-DN32H	XBM/XEM-DN32HP (H2)	XGB-UP
R40H/20HH-05S-XBM3	-	-	-	-	-	-	●	●	-	-	-
R40H/20HH-10S-XBM3	-	-	-	-	-	-	●	●	-	-	-
C40HH-05SB-XBI	●	●	●	●	●	●	-	-	●	●	●
C40HH-10SB-XBI	●	●	●	●	●	●	-	-	●	●	●
C40HH-15SB-XBI	●	●	●	●	●	●	-	-	●	●	●
C40HH-20SB-XBI	●	●	●	●	●	●	-	-	●	●	●
C40HH-30SB-XBI	●	●	●	●	●	●	-	-	●	●	●
C40HH-05SB-XBE	-	-	-	-	●	●	-	-	-	-	-
C40HH-10SB-XBE	-	-	-	-	●	●	-	-	-	-	-
C40HH-15SB-XBE	-	-	-	-	●	●	-	-	-	-	-
C40HH-20SB-XBE	-	-	-	-	●	●	-	-	-	-	-
C40HH-30SB-XBE	-	-	-	-	●	●	-	-	-	-	-
C40HH-05SB-XBE	-	-	-	-	●	-	-	-	-	-	-
C40HH-10SB-XBE	-	-	-	-	●	-	-	-	-	-	-
C40HH-15SB-XBE	-	-	-	-	●	-	-	-	-	-	-
C40HH-20SB-XBE	-	-	-	-	●	-	-	-	-	-	-
C40HH-30SB-XBE	-	-	-	-	●	-	-	-	-	-	-

Download cable diagram

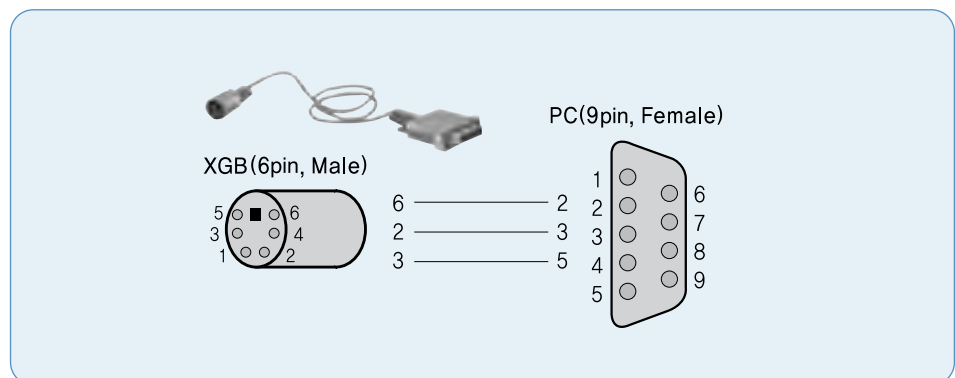

Block type unit

XBC/XEC-U (Standard)

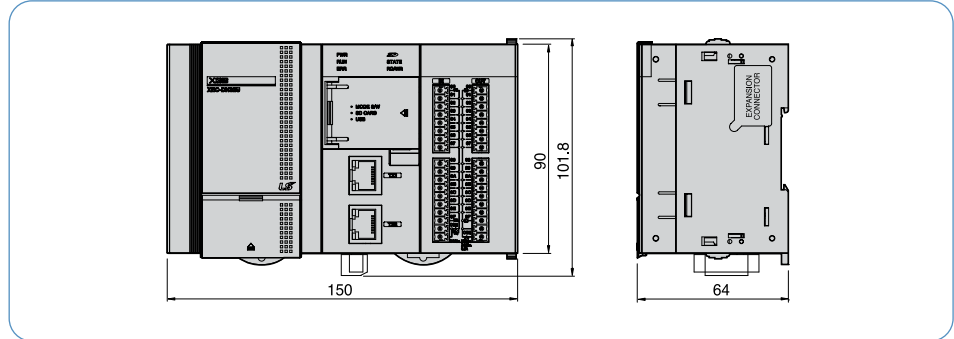

XBC/XEC-H

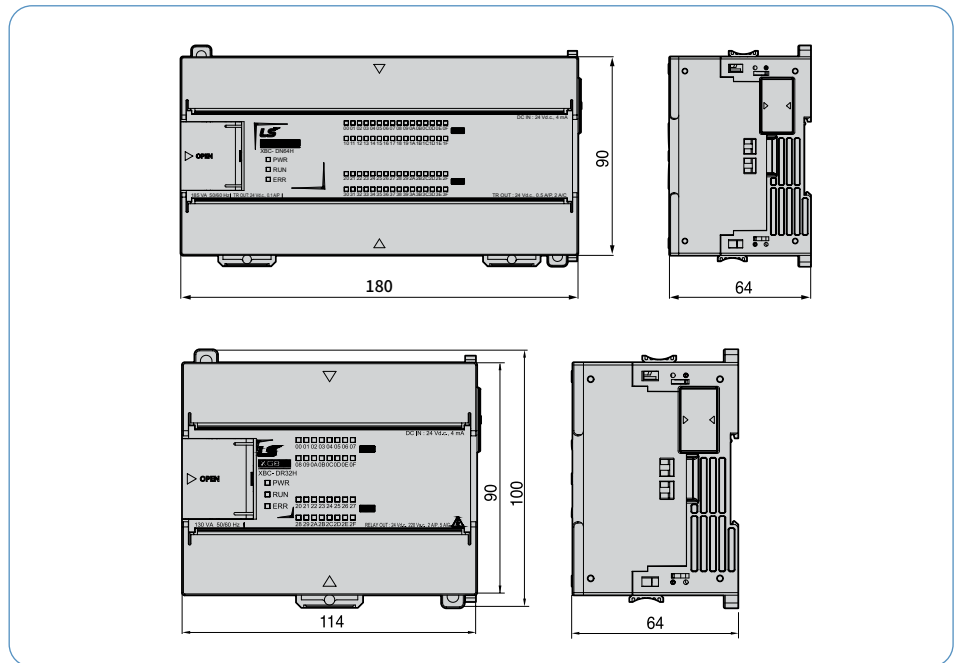

XBC/XEC-SU

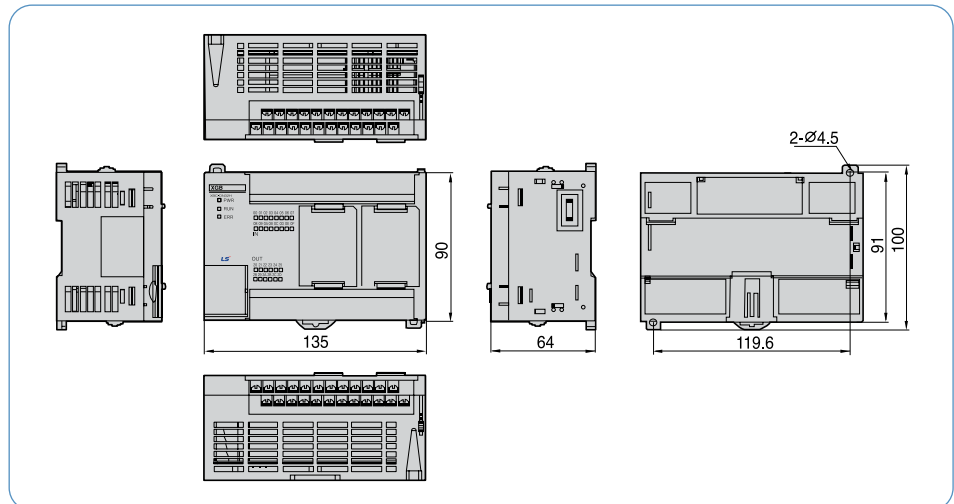

XBC/XEC-E

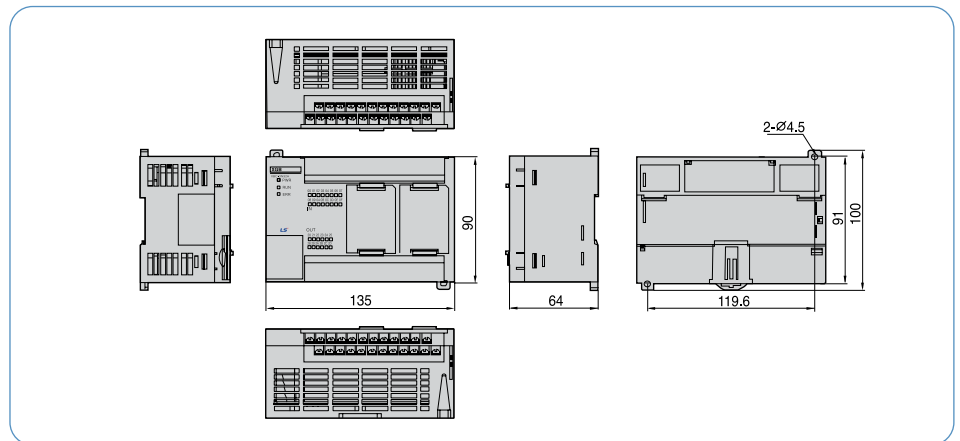
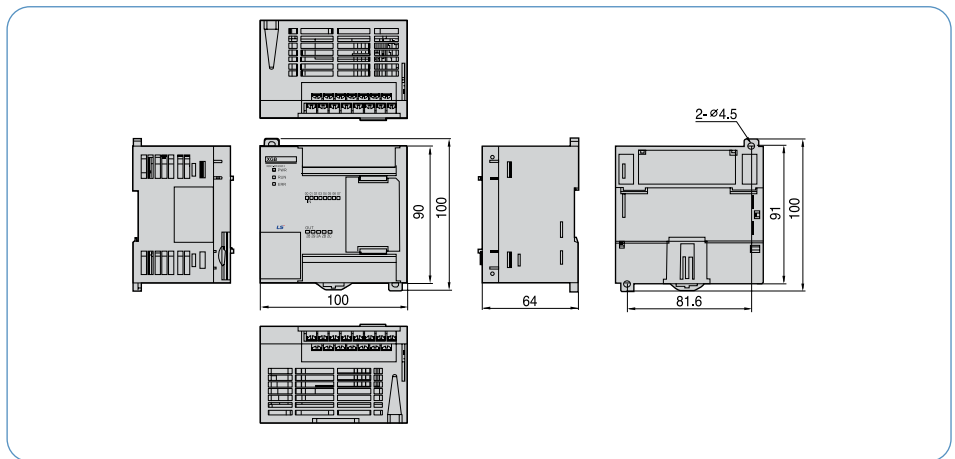

Modular type unit

XBM-S

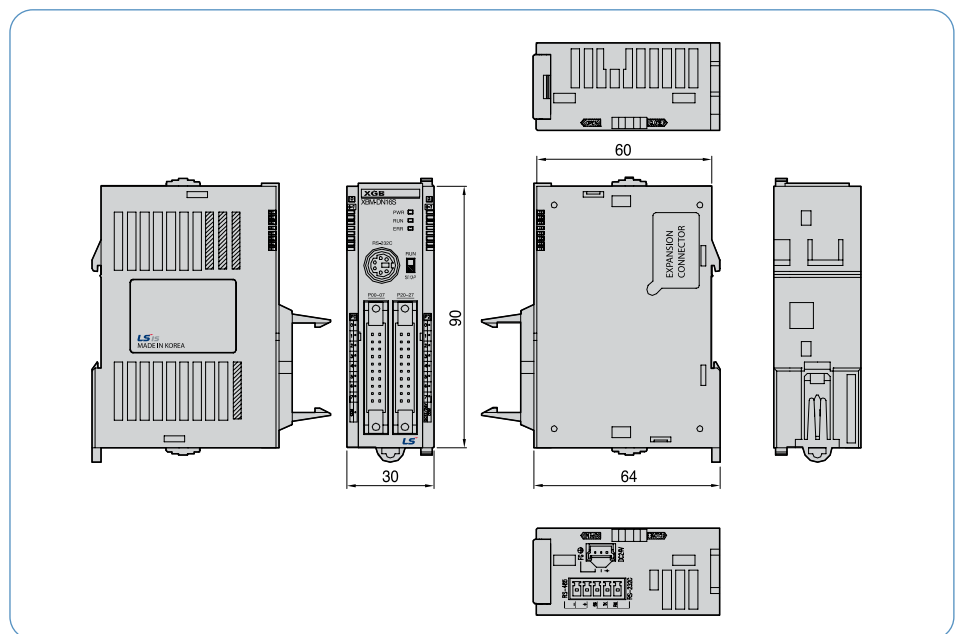

Modular type unit

XBM-32H/H2/HP
XBM-16H2, XBM-DR14H2

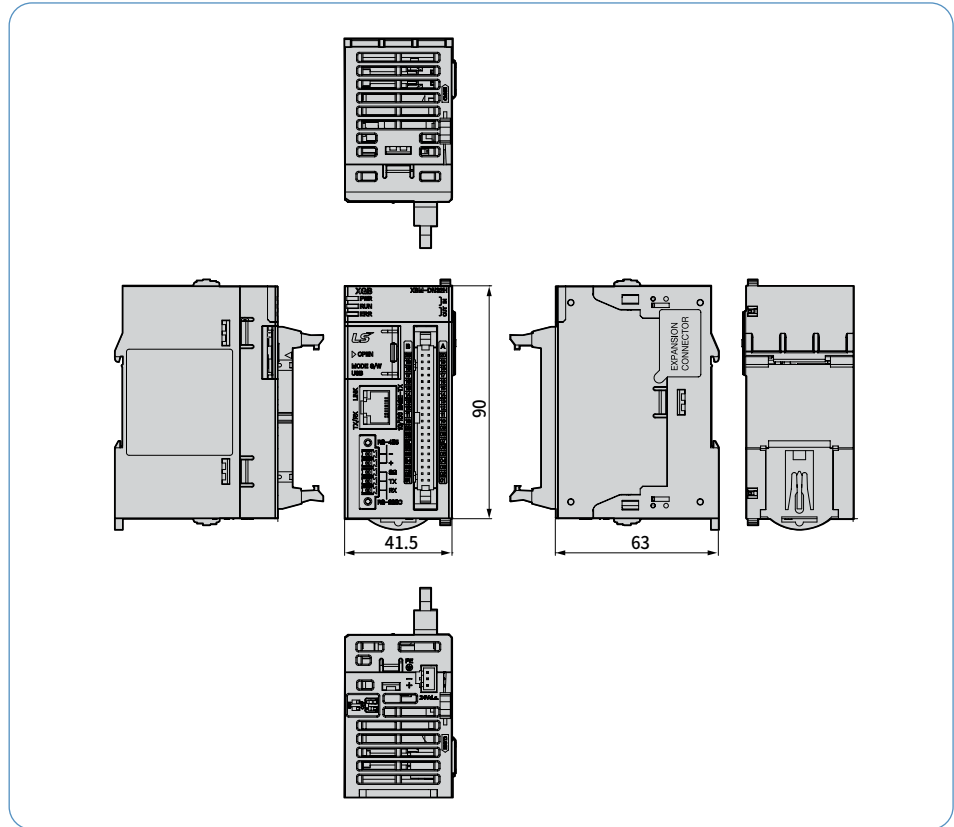

XBM-16H2, XBM-DR14H2

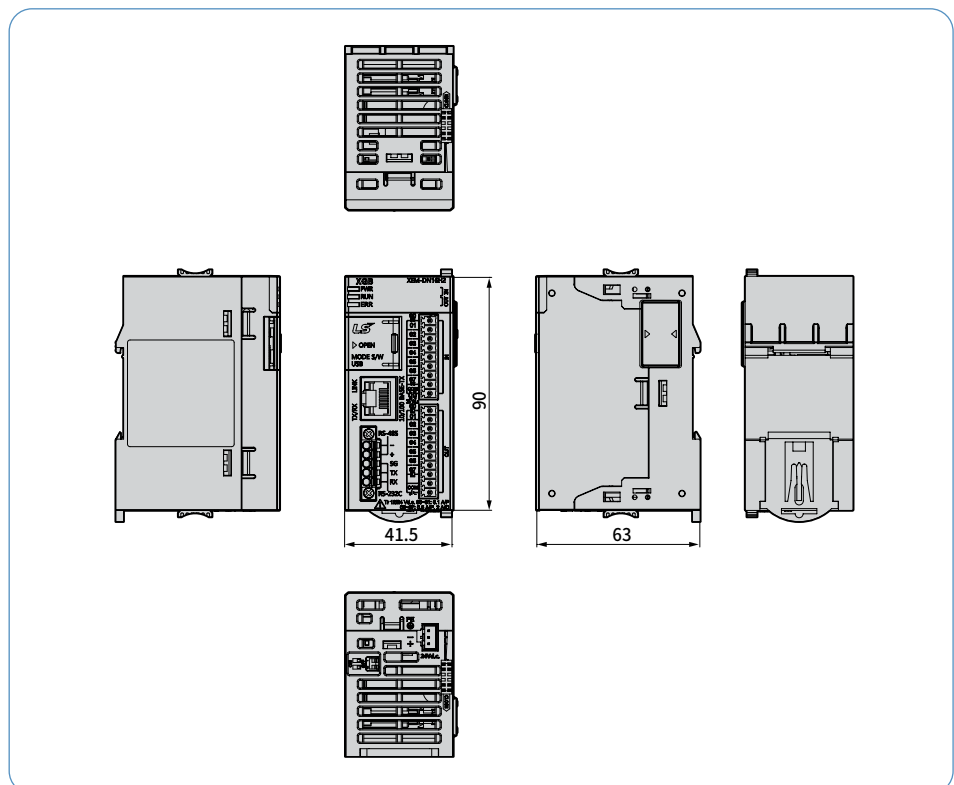

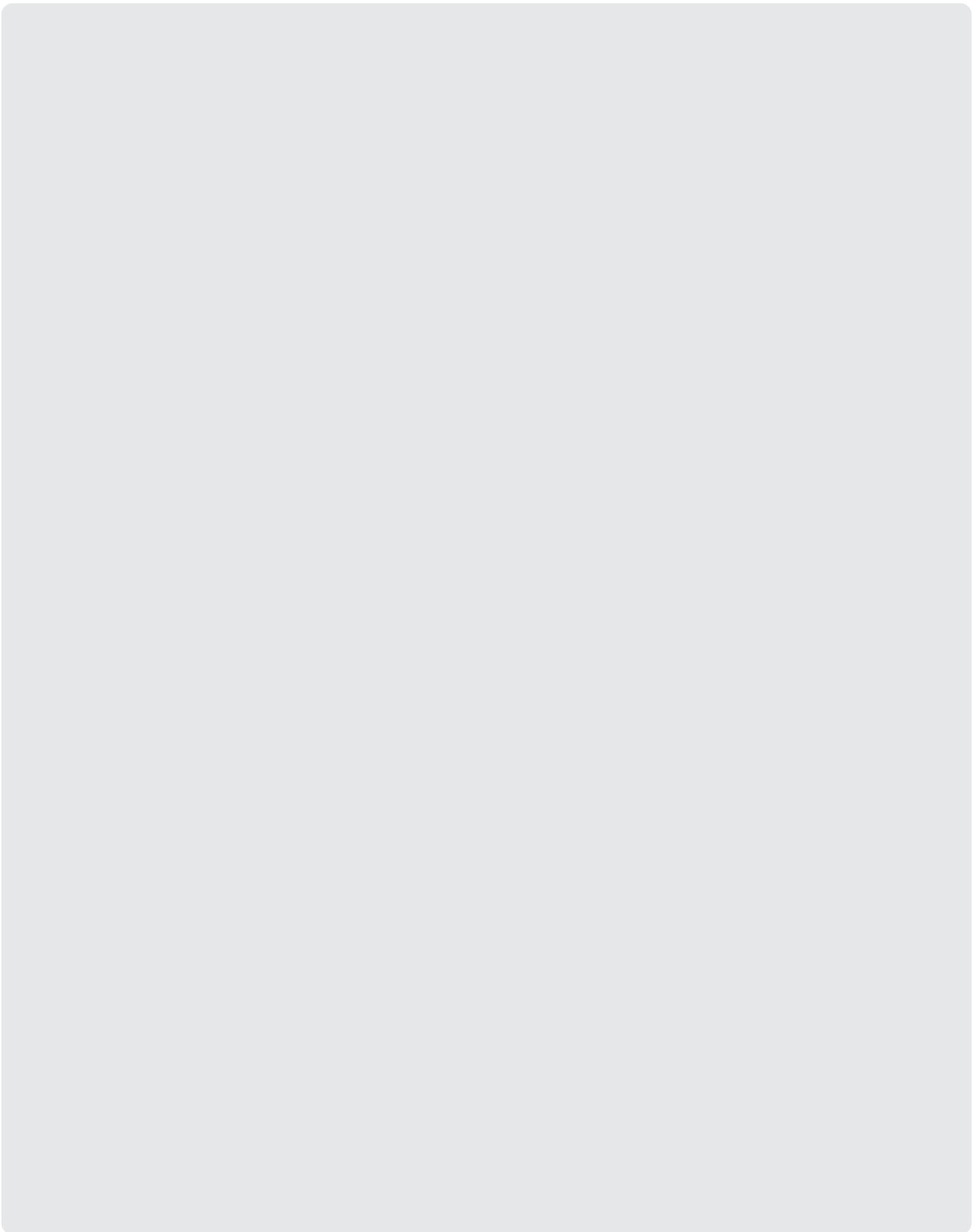

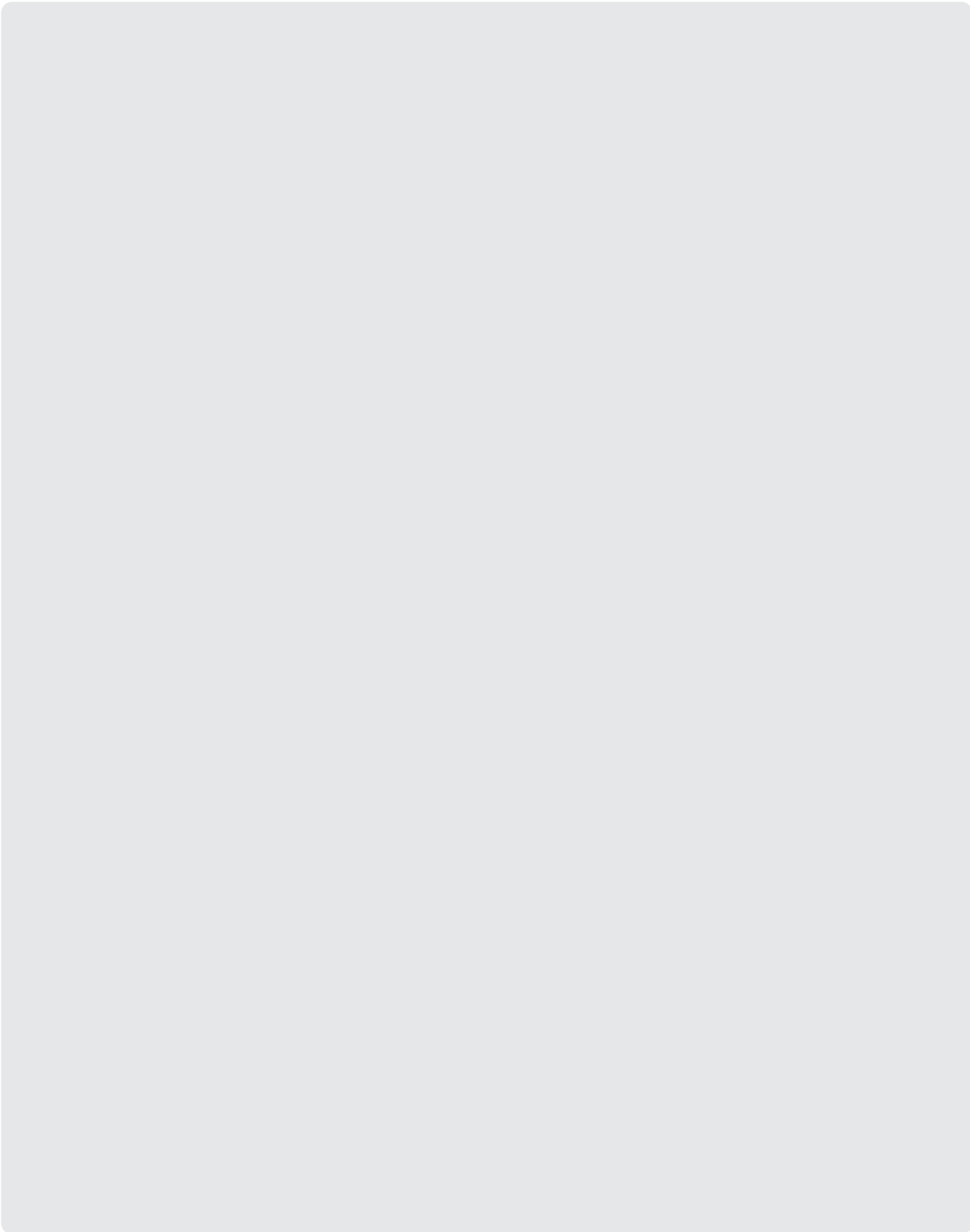

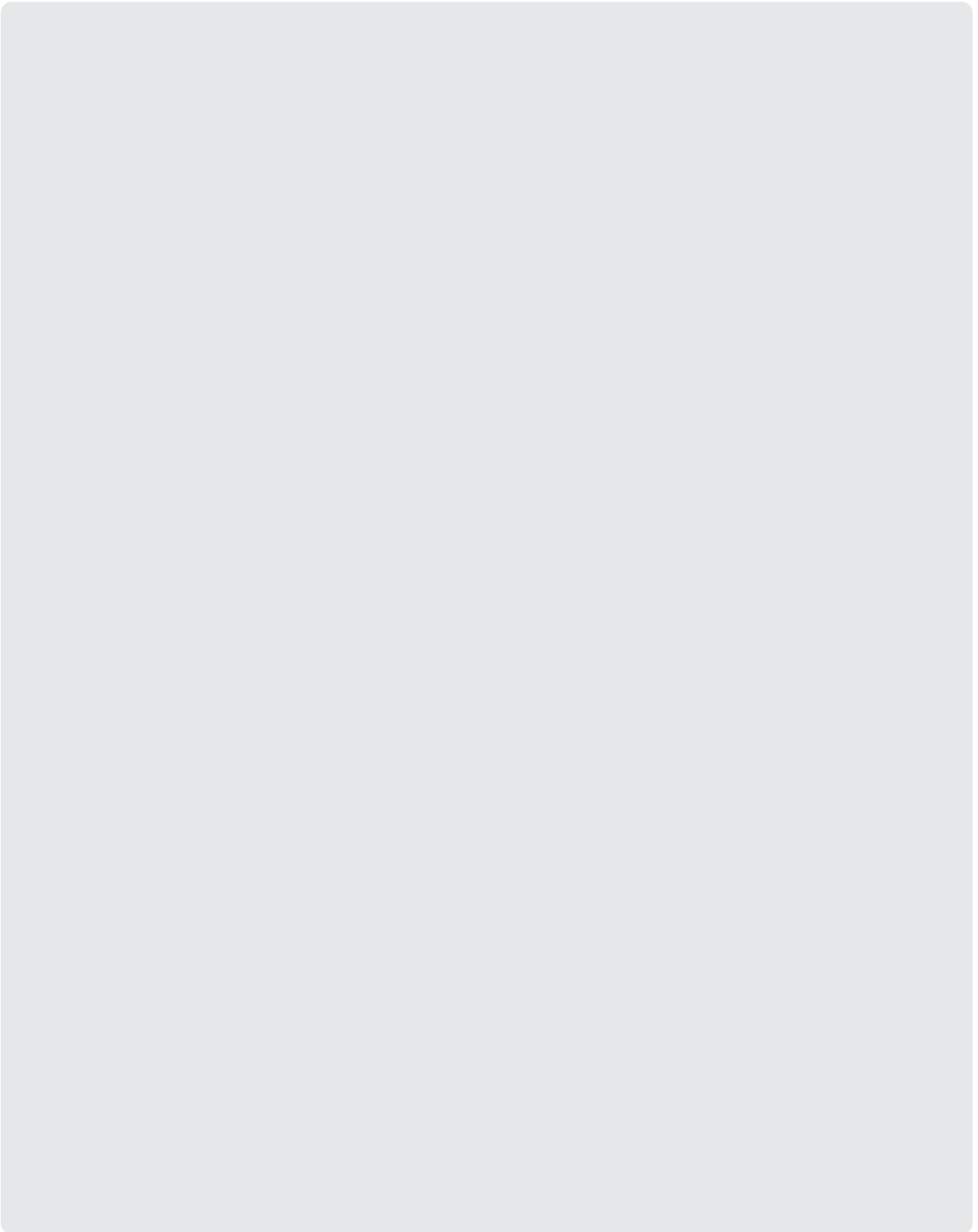



Safety Instructions

- For your safety, please read user's manual thoroughly before operating.
- Contact the nearest authorized service facility for examination, repair, or adjustment.
- Please contact qualified service technician when you need maintenance. Do not disassemble or repair by yourself!
- Any maintenance and inspection shall be performed by the personnel having expertise concerned.



- According to The WEEE Directive, please do not discard the device with your household waste.



www.ls-electric.com

■ Headquarter

LS-ro 127(Hogye-dong) Dongan-gu, Anyang-si, Gyeonggi-Do, 14119, Korea

■ Seoul Office

LS Yongsan Tower, 92, Hangang-daero, Yongsan-gu, Seoul, 04386, Korea
Tel: 82-2-2034-4033, 4888, 4703 Fax: 82-2-2034-4588
E-mail: automation@ls-electric.com

■ Overseas Subsidiaries

- **LS ELECTRIC Japan Co., Ltd. (Tokyo, Japan)**
Tel: 81-3-6268-8241 E-Mail: japan@ls-electric.com
- **LS ELECTRIC (Dalian) Co., Ltd. (Dalian, China)**
Tel: 86-411-8730-6495 E-Mail: china.dalian@lselectric.com.cn
- **LS ELECTRIC (Wuxi) Co., Ltd. (Wuxi, China)**
Tel: 86-510-6851-6666 E-Mail: china.wuxi@lselectric.com.cn
- **LS ELECTRIC Middle East FZE (Dubai, U.A.E.)**
Tel: 971-4-886-5360 E-Mail: middleeast@ls-electric.com
- **LS ELECTRIC Europe B.V. (Hoofddorp, Netherlands)**
Tel: 31-20-654-1424 E-Mail: europartner@ls-electric.com
- **LS ELECTRIC America Inc. (Chicago, USA)**
Tel: 1-800-891-2941 E-Mail: sales.us@lselectricamerica.com
- **LS ELECTRIC Türkiye Co., Ltd.**
Tel: 90-212-806-1225 E-Mail: Türkiye@ls-electric.com

■ Overseas Branches

- **LS ELECTRIC Tokyo Office (Japan)**
Tel: 81-3-6268-8241 E-Mail: tokyo@ls-electric.com
- **LS ELECTRIC Beijing Office (China)**
Tel: 86-10-5095-1631 E-Mail: china.auto@lselectric.com.cn
- **LS ELECTRIC Shanghai Office (China)**
Tel: 86-21-5237-9977 E-Mail: china.auto@lselectric.com.cn
- **LS ELECTRIC Guangzhou Office (China)**
Tel: 86-20-3818-2883 E-Mail: china.auto@lselectric.com.cn
- **LS ELECTRIC Chengdu Office (China)**
Tel: 86-28-8670-3201 E-Mail: china.auto@lselectric.com.cn
- **LS ELECTRIC Qingdao Office (China)**
Tel: 86-532-8501-2065 E-Mail: china.auto@lselectric.com.cn
- **LS ELECTRIC Nanjing Office (China)**
Tel: 86-25-8467-0005 E-Mail: china.auto@lselectric.com.cn
- **LS ELECTRIC Bangkok Office (Thailand)**
Tel: 66-90-950-9683 E-Mail: thailand@ls-electric.com
- **LS ELECTRIC Jakarta Office (Indonesia)**
Tel: 62-21-2933-7614 E-Mail: indonesia@ls-electric.com
- **LS ELECTRIC Moscow Office (Russia)**
Tel: 7-499-682-6130 E-Mail: info@lselectric-ru.com
- **LS ELECTRIC America Western Office (Irvine, USA)**
Tel: 1-949-333-3140 E-Mail: america@ls-electric.com
- **LS ELECTRIC Italy office (Italy)**
Tel: 39-030-8081-833 E-Mail: italia@ls-electric.com