

The right choice for the ultimate yield!

LS ELECTRIC strives to maximize your profits in gratitude for choosing us as your partner.

## Programmable Logic Control

# XGB Analog

### XGT Series

### User Manual

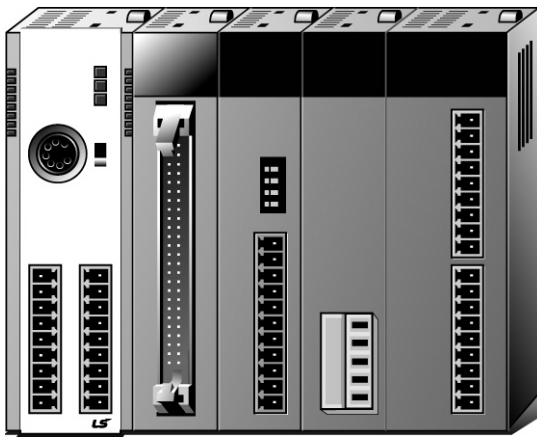

Analog input

XBF-AD04A

XBF-AD04C

XBF-AD08A

Analog output

XBF-DV04A

XBF-DV04C

XBF-DC04A

XBF-DC04C

Temperature input

XBF-RD04A

XBF-TC04S

Analog input/output

XBF-AH04A

Analog input option board

XBO-AD02A

Analog output option board

XBO-DA02A

Analog input/output option board

XBO-AH02A

Temperature input option board

XBO-RD01A

XBO-TC02A



Built-in PID



### Safety Instructions

- Read this manual carefully before installing, wiring, operating, servicing or inspecting this equipment.
- Keep this manual within easy reach for quick reference.

**LS**ELECTRIC

The right choice for the ultimate yield!

LS ELECTRIC strives to maximize your profits in gratitude for choosing us as your partner.

## Programmable Logic Control

# XGB Analog

### XGT Series

### User Manual

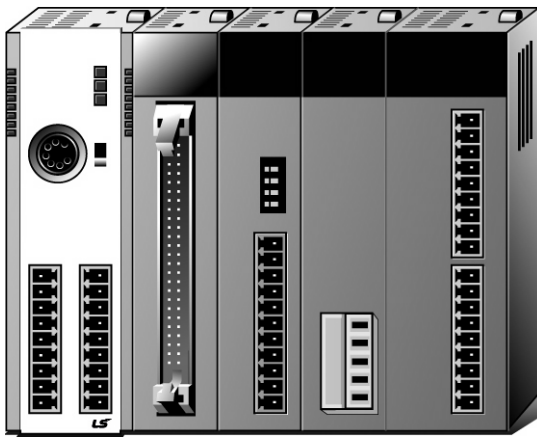

Analog input

XBF-AD04A

XBF-AD04C

XBF-AD08A

Analog output

XBF-DV04A

XBF-DV04C

XBF-DC04A

XBF-DC04C

Temperature input

XBF-RD04A

XBF-TC04S

Analog input/output

XBF-AH04A

Analog input option board

XBO-AD02A

Analog output option board

XBO-DA02A

Analog input/output option board

XBO-AH02A

Temperature input option board

XBO-RD01A

XBO-TC02A



Built-in PID



### Safety Instructions

- Read this manual carefully before installing, wiring, operating, servicing or inspecting this equipment.
- Keep this manual within easy reach for quick reference.

**LS**ELECTRIC

## Safety Instructions for Design Process

### **Caution**

- ▶ **Design the analog input / output signal or pulse input / output line at least 100mm away from high voltage line or power line so that it is not affected by noise or magnetic field change.** It may cause malfunction due to noise.
- ▶ **If there is a lot of vibration in the installation environment, take measures to prevent direct vibration from being applied to the PLC.** It may cause electric shock, fire or malfunction.
- ▶ **If metallic dust is present in the installation environment, take measures to prevent metallic dust from entering the product.** It may cause electric shock, fire or malfunction.

## Safety Instructions on Installation Process

### **Caution**

- ▶ **Use PLC only in the environment specified in PLC manual or general standard of datasheet.**  
If not, electric shock, fire, abnormal operation of the product may be caused.
- ▶ **Before install or remove the module, be sure PLC power is off.** If not, electric shock or damage on the product may be caused.
- ▶ **Be sure that every module is securely attached after adding a module or an extension connector.** If the product is installed loosely or incorrectly, abnormal operation, error or dropping may be caused. In addition, contact failures under poor cable installation will be causing malfunctions as well.
- ▶ **Make sure that the I / O connector is securely fastened.** It may cause wrong input or output.

## Safety Instructions for Wiring Process

### **Warning**

- ▶ **Prior to wiring works, make sure that every power is turned off.** If not, electric shock or damage on the product may be caused.

### **Caution**

- ▶ **Check rated voltages and terminal arrangements in each product prior to its wiring process.** Applying incorrect voltages other than rated voltages and misarrangement among terminals may cause fire or malfunctions.
- ▶ **Secure terminal screws tightly applying with specified torque.** If the screws get loose, short circuit, fire or abnormal operation may be caused. Securing screws too tightly will cause damages to the module or malfunctions, short circuit, and dropping.
- ▶ **Be sure to earth to the ground using Class 3 wires for PE terminals which is exclusively used for PLC.** If the terminals not grounded correctly, abnormal operation or electric shock may be caused.
- ▶ **Don't let any foreign materials such as wiring waste inside the module while wiring,** which may cause fire, damage on the product or abnormal operation.



## Safety Instructions for Test-Operation and Maintenance

### Warning

- ▶ **Don't touch the terminal when powered.** Electric shock or abnormal operation may occur.
- ▶ **Prior to cleaning or tightening the terminal screws, let all the external power off including PLC power.** If not, electric shock or abnormal operation may occur.

### Caution

- ▶ **Do not make modifications or disassemble each module.**  
Fire, electric shock or abnormal operation may occur.
- ▶ **Prior to installing or disassembling the module, let all the external power off including PLC power.** If not, electric shock or abnormal operation may occur.
- ▶ **Keep any wireless equipment such as walkie-talkie or cell phones at least 30cm away from PLC.** If not, abnormal operation may be caused.

## Safety Instructions for Waste Disposal

### Caution

- ▶ **Product or battery waste shall be processed as industrial waste.** The waste may discharge toxic materials or explode itself.

# Revision History

Version	Date	Remark	Revised position
V 1.0	2007. 7	1. Adding contents (1) Setting Sequence before operation (2) Accuracy calculation example 2. Changing contents (1) Wiring examples (2) Configuration and Function of Internal Memory (3) Example Program	2-1,3-1,4-1 2-9,3-7 2-13,3-9,4-9 2-28,3-18,4-20 2-33,3-23,4-24,5-37
V 1.1	2008. 1	1. Adding model (1) Thermocouple input module (XBF-TC04S) 2. Adding contents (1) Thermo electromotive force and compensating cable (2) Performance Specification (3) Dimension 3. Changing chapter number (1) CH.6 PID Function (2) Appendix 3. Dimension	5-1 ~ 5-54 Appendix 2 1-5 APP.3-3 CH 5 → CH6 App.2 --> App.3
V1.2	2008.4	1. Adding XGB compact 'H' type	All over
V1.3	2009.2	1. Adding contents about XGB IEC type	All over
V1.4	2009.7	1. Adding model (1) Analog combo module (XBF-AH04A) 2. Adding/changing contents (1) Adding contents at chapter 1 (2) Adding dimension	6-1 ~ 6-48 1-1,1-6,1-7 Appendix3-3
V1.5	'20.4	Format and contents modification according to the change of company name(LSIS → LS ELECTRIC)	-
V1.6	2011.2	1. Adding new model (1) Analog Input Option Board (XBO-AD02A) (2) Analog Output Option Board(XBO-DA02A) (3) Analog IO Option Board(XBO-AH02A) (4) RTD Input Option Board(XBO-RD01A) (5) Thermocouple Input Option Board(XBO-TC02A) (6) Thermocouple Voltage Input (XBF-TC04B) 2. Contents added/modified (1) CH.8 PID moved to CH13	8-1 ~ 8-35 9-1 ~ 9-35 10-1 ~ 10-44 11-1 ~ 11-27 12-1 ~ 12-35 5-1 ~ 5-60 CH8 → CH13

Version	Date	Remark	Revised position
V1.7	2012.8	1. Adding new model	
		(1) XBF-AD04C	13-1 ~ 13-47
		(2) XBF-DV04C/DC04C	14-1 ~ 14-41
		2. Changing contents	
		(1) CH.13 PID moved to CH15	CH13 → CH1
V1.8	2014.1	1. Adding Analog/Temp option board IEC Memory Area	
		(1) XBO-AD02A/DA02A/AH02A	8-26,9-22,10-32
		(2) XBO-RD01A/TC02A	11-20,12-24
V1.9	2014.3	1. Revision of content error	
		(1) XBF-DC04C Current Resolution	14-3
V2.0	2015.7	1. Domain name changed	2-2,3-2,4-2,5-2,6-2
		2. General specifications changed by reason of IEC Specifications.	7-2,8-2,9-2,10-2,11-2
			12-2,13-2,14-2
V2.1	2020.06	Corporate Identity changed (LSIS →LS ELECTRIC)	Entire
V2.2	2021.10	1.XBF-AD04A input range setting correction	2-31
		2. Updating the maximum number of supported models	1-3~1-8,1-10,1-12
			2-3,3-3,4-3,5-6,6-4,7-3
			13-3,14-3

Thank you for purchasing PLC of LS ELECTRIC Co., Ltd.

Before use, make sure to carefully read and understand the User's Manual about the functions, performances, installation and programming of the product you purchased in order for correct use and importantly, let the end user and maintenance administrator to be provided with the User's Manual.

The User's Manual describes the product. If necessary, you may refer to the following description and order accordingly. In addition, you may connect our website (<http://www.ls-electric.com/>) and download the information as a PDF file.

### Relevant User's Manuals

Title	Description
XG5000 user's manual	It describes how to use XG5000 software about online functions such as programming, printing, monitoring and debugging by using XGB series products.
XG5000 user's manual (for XGI/XGR/XEC)	It describes how to use XG5000 software about online functions such as programming, printing, monitoring and debugging by using XGB (IEC language)
XGK/XGB Instructions & Programming	It is the user's manual for programming to explain how to use commands that are used PLC system with XGB CPU.
XGI/XGR/XEC Instructions & Programming	It is the user's manual for programming to explain how to use commands that are used in XGB (IEC language)
XGB hardware	It describes power, IO, extension specification and system configuration, built-in high speed counter of XGB main unit.
XGB hardware (IEC)	It describes power, IO, extension specification and system configuration, built-in high speed counter of XGB (IEC) main unit.
XGB Analog user's manual	It describes how to use the specification of analog input/analog output/temperature input module, system configuration and built-in PID control for XGB basic unit.
XGB Position User's manual	It describes how to use the specification of analog input/analog output/temperature input module, system configuration and built-in PID control for XGB basic unit.
XGB Cnet I/F	It is the user's manual about XGB Cnet I/F that describes built-in communication function and external Cnet I/F module of XGB basic unit
XGB FEnet I/F	It describes how to use XGB FEnet I/F module.
XBC Standard /Economic Type Main Unit	It describes power, I/O, extension specification and system configuration, built-in high speed counter of XGB standard / economic type main unit.
XGB High speed counter User's Manual	It is the user's manual for High speed counter extension module of XGB basic unit to explain High speed counter extension module function of XGB basic unit.
XGB Fast Ethernet I/F	It describes how to use XGB FEnet I/F module.
XGB CANopen I/F	It describes how to use the CANopen that is kind of opened type network.

# ◎ Table of Contents ◎

## **Chapter 1 General .....1-1~1-17**

- 1.1 Analog Product List ..... 1-1
- 1.2 Specification of Analog Module ..... 1-3

## **Chapter 2 Analog Input Module (XBF-AD04A) .....2-1~2-43**

- 2.1 Setting Sequence before Operation .....2-1
- 2.2 Specifications .....2-2
- 2.3 Name of part and function .....2-4
- 2.4 Characteristic of I/O conversion .....2-5
- 2.5 Conversion Characteristic according to Input Range .....2-6
- 2.6 Accuracy .....2-9
- 2.7 Functions of Analog Input Module .....2-10
- 2.8 Wiring .....2-13
- 2.9 Operation Parameter Setting .....2-17
- 2.10 Special Module Monitoring Functions .....2-19
- 2.11 Register U devices .....2-24
- 2.12 Configuration and Function of Internal Memory .....2-28
- 2.13 Example Program .....2-34
- 2.14 Troubleshooting .....2-40

## **Chapter 3 Analog Output Module (XBF-DV04A / XBF-DC04A / XBF-DC04B) .....3-1~3-29**

- 3.1 Setting Sequence before Operation .....3-1
- 3.2 Specification .....3-2
- 3.3 Designations and Functions .....3-4
- 3.4 Characteristic of I/O Conversion .....3-5
- 3.5 Characteristic of Input/Output .....3-6
- 3.6 Accuracy .....3-7
- 3.7 Functions of Analog Output Module .....3-8
- 3.8 Wiring .....3-9
- 3.9 Operation Parameter Setting .....3-10
- 3.10 Special Module Monitoring Function .....3-12
- 3.11 Register U devices .....3-15
- 3.12 Internal memory .....3-19
- 3.13 Example Program .....3-25
- 3.14 Troubleshooting .....3-27

**Chapter 4 RTD Input Module (XBF-RD04A / XBF-RD01A).....4-1~4-30**

4.1 Setting Sequence before Operation .....	4-1
4.2 Specification .....	4-2
4.3 Part Names and Functions .....	4-4
4.4 Temperature Conversion Characteristic .....	4-5
4.5 Conversion Speed .....	4-6
4.6 Accuracy .....	4-6
4.7 Temperature Display .....	4-6
4.8 Scaling Function .....	4-7
4.9 Disconnection Detection Function .....	4-8
4.10 Wiring .....	4-9
4.11 Filtering Function .....	4-11
4.12 Operation Parameter Setting .....	4-12
4.13 Special Module Monitoring .....	4-15
4.14 Register U devices .....	4-18
4.15 Configuration and Function of Internal Memory .....	4-21
4.16 Example Program .....	4-25
4.17 Trouble Shooting .....	4-28

**Chapter 5 Thermocouple Input Module (XBF-TC04S / XBF-TC04B) .....5-1~5-60**

5.1 General.....	5-1
5.2 Specification.....	5-4
5.3 Function .....	5-14
5.4 Installation and Wiring.....	5-19
5.5 Operation Setting and Monitor .....	5-22
5.6 Configuration and Function of Internal Memory .....	5-36
5.7 Example Program .....	5-51
5.8 Troubleshooting .....	5-56

**Chapter 6 Analog I/O Module (XBF-AH04A).....6-1~6-48**

6.1 Pre-operation Setting Procedure .....	6-1
6.2 Specification.....	6-2
6.3 Major Components.....	6-5
6.4 Conversion Characteristics by I/O Range.....	6-6
6.5 Precision .....	6-10
6.6 Functions of Analog I/O Module.....	6-12
6.7 Wiring.....	6-18

6.8 Operation Parameter Setting .....	6-22
6.9 Special Module Monitor Function.....	6-24
6.10 Auto-registration of U-Device (Special Module Variable) .....	6-28
6.11 Constitution and Function of Internal Memory .....	6-33
6.12 Example Program .....	6-40
6.13 Troubleshooting .....	6-46

<b>Chapter 7 Analog Input Module (XBF-AD08A) .....</b>	<b>7-1~7-39</b>
--	-----------------

7.1 Setting Sequence before Operation.....	7-1
7.2 Specifications .....	7-2
7.3 Name of part and function .....	7-4
7.4 Characteristic of I/O conversion .....	7-5
7.5 Accuracy .....	7-7
7.6 Functions of Analog Input Module .....	7-8
7.7 Wiring .....	7-13
7.8 Operation Parameter Setting .....	7-16
7.9 Special Module Monitoring Functions .....	7-19
7.10 Register U devices .....	7-23
7.11 Configuration and Function of Internal Memory .....	7-28
7.12 Example Program .....	7-35
7.13 Troubleshooting .....	7-37

<b>Chapter 8 Analog Input Option Board (XBO-AD02A) .....</b>	<b>8-1~8-35</b>
--	-----------------

8.1 Setting Sequence before Operation.....	8-1
8.2 Specifications .....	8-2
8.3 Name of part and function .....	8-4
8.4 Characteristic of I/O conversion .....	8-5
8.5 Accuracy .....	8-7
8.6 Functions of Analog Input Option Board .....	8-8
8.7 Wiring .....	8-11
8.8 Operation Parameter Setting .....	8-13
8.9 Special Module Monitoring Functions .....	8-16
8.10 Register U devices .....	8-20
8.11 Configuration and Function of Internal Memory .....	8-25
8.12 Example Program .....	8-33
8.13 Troubleshooting .....	8-35

**Chapter 9 Analog Output Option Board (XBO-DA02A).....9-1~9-31**

9.1 Setting Sequence before Operation.....	9-1
9.2 Specifications .....	9-2
9.3 Name of part and function .....	9-4
9.4 Characteristic of I/O conversion .....	9-5
9.5 Accuracy .....	9-7
9.6 Functions of Analog Output Option Board .....	9-8
9.7 Wiring .....	9-10
9.8 Operation Parameter Setting .....	9-11
9.9 Special Module Monitoring Functions .....	9-13
9.10 Register U devices .....	9-16
9.11 Internal memory .....	9-21
9.12 Example Program .....	9-29
9.13 Troubleshooting .....	9-31

**Chapter 10 Analog I/O Option Board (XBO-AH02A).....10-1~10-44**

10.1 Setting Sequence before Operation.....	10-1
10.2 Specifications .....	10-2
10.3 Name of part and function .....	10-5
10.4 Characteristic of I/O conversion .....	10-6
10.5 Accuracy .....	10-10
10.6 Functions of Analog Output Option Board .....	10-12
10.7 Wiring .....	10-16
10.8 Operation Parameter Setting .....	10-20
10.9 Special Module Monitoring Functions .....	10-22
10.10 Register U devices .....	10-26
10.11 Configuration and Function of Internal Memory.....	10-31
10.12 Example Program .....	10-41
10.13 Troubleshooting .....	10-43

**Chapter 11 RTD Input Option Board (XBO-RD01A).....11-1~11-27**

11.1 Setting Sequence before Operation.....	11-1
11.2 Specifications .....	11-2
11.3 Name of part and function .....	11-4
11.4 Temperature Conversion Characteristic .....	11-5
11.5 Conversion Speed.....	11-6
11.6 Accuracy .....	11-6



11.7 Temperature Display.....	11-6
11.8 Disconnection Detection Function .....	11-7
11.9 Wiring .....	11-8
11.10 Average Function .....	11-10
11.11 Operation Parameter Setting .....	11-11
11.12 Special Module Monitoring Functions .....	11-14
11.13 Register U devices .....	11-17
11.14 Configuration and Function of Internal Memory.....	11-20
11.15 Example Program .....	11-25
11.16 Troubleshooting .....	11-27

<b>Chapter 12 Thermocouple Input Option Module (XBF-TC02A) .....</b>	<b>12-1~12-35</b>
--	-------------------

12.1 Setting Sequence before Operation.....	12-1
12.2 Specifications .....	12-2
12.3 Name of Part and Function .....	12-4
12.4 Characteristic of Thermocouple Temperature Conversion .....	12-5
12.5 Accuracy .....	12-6
12.6 Conversion Speed.....	12-7
12.7 Function .....	12-8
12.8 Installation and Wiring.....	12-10
12.9 Operation Setting and Monitor .....	12-12
12.10 Configuration and Function of Internal Memory.....	12-24
12.11 Example Program .....	12-31
12.12 Troubleshooting .....	12-34

<b>Chapter 13 Analog Input Module (XBF-AD04C).....</b>	<b>13-1~13-47</b>
--	-------------------

13.1 Setting Sequence before Operation.....	13-1
13.2 Specifications .....	13-2
13.3 Name of each Part and Functions .....	13-5
13.4 Characteristic of I/O Conversion .....	13-6
13.5 Accuracy .....	13-8
13.6 Functions of Analog Input Module .....	13-9
13.7 Installation and Separation of Module.....	13-16
13.8 Operation Parameter Setting .....	13-22
13.9 Special Module Monitoring Functions .....	13-25
13.10 Register U Devices .....	13-29
13.11 Configuration and Function of Internal Memory.....	13-36
13.12 Example Program .....	13-43

13.13 Breakdown Test .....	13-45
----------------------------	-------

<b>Chapter 14 Analog Output Module (XBF-DV04C/XBF-DC04C) .....</b>	<b>14-1~14-41</b>
--	-------------------

14.1 Setting Sequence before Operation.....	14-1
14.2 Specifications .....	14-2
14.3 Name of each Part and Functions .....	14-5
14.4 Conversion Characteristic of each Output Range .....	14-6
14.5 Accuracy .....	14-9
14.6 Functions of Analog Output Module.....	14-10
14.7 Installation and Wiring.....	14-14
14.8 Operation Parameter Setting .....	14-18
14.9 Special Module Monitoring Functions .....	14-21
14.10 Register U Devices .....	14-24
14.11 Internal Memory .....	14-28
14.12 Example Program .....	14-36
14.13 Breakdown Test .....	14-39

<b>Chapter 15 PID Function (Built-in function).....</b>	<b>15-1~15-55</b>
---	-------------------

15.1 General .....	15-1
15.2 PID Control .....	15-3
15.3 PID Instructions .....	15-27
15.4 PID Auto-tuning .....	15-33
15.5 Example Programs .....	15-42
15.6 Error/Warning Codes .....	15-54

<b>Appendix .....</b>	<b>App.1-3</b>
-----------------------	----------------

Appendix 1 Standard Resistor of Pt RTD .....	App.1-1
Appendix 2 Thermo Electromotive Force and Compensating Cable .....	App.2-1
Appendix 3 Dimension .....	App.3-1

# Chapter 1 General

Here describes about analog module and built-in PID function of XGB series.

## 1.1 Analog Product List

Classification	Name	No. of channel	Range	Resolution	Characteristic
Voltage/ Current input	XBF-AD04A	4	0 ~ 10V	2.5 mV	1.Range selection by external switch and parameter setting 2. External DC24V used
			0 ~ 20 mA 4mA~20mA	5.0 $\mu$ A	
	XBF-AD04C	4	1 ~ 5V	0.250mV	1.Range selection by external switch and parameter setting 2 Function of. Filter, Average, Detection disconnection, Alarm, Retaining Valid conversion value 3. External DC24V used
			0 ~ 5V	0.3125mV	
			0 ~ 10V	0.625mV	
			$\pm$ 10V	1.250mV	
			4 ~ 20mA	1.0 $\mu$ A	
	XBF-AD08A	8	4~20mA 0~20mA	5.0 $\mu$ A	1.Range selection by external switch and parameter setting 2. Filter function, average function 3. External DC24V used
			1~5V 0~5V	1.25 mV	
			0~10V	2.5 mV	
Voltage output	XBF-DV04A	4	0 ~ 10V	2.5 mV	1. External DC24V used 2. Designates output in case of Error and CPU STOP 3. Interpolation function (Linear, S-type)
	XBF-DV04C	4	1 ~ 5V	0.250mV	
			0 ~ 5V	0.3125mV	
			0 ~ 10V $\pm$ 10V	0.625mV 1.250mV	
Current output	XBF-DC04A	4	0 ~ 20mA 4mA~20mA	5.0 $\mu$ A	1. External DC24V used 2. Designates output in case of Error and CPU STOP
	XBF-DC04B	4	0 ~ 1.2mA	0.3 $\mu$ A	
	XBF-DC04C	4	4~20mA	1.0 $\mu$ A	1. 1. External DC24V used 2. Designates output in case of Error and CPU STOP 3. Interpolation Function(Linear, S-type) 4. Detection disconnection
			0 ~ 20mA	1.25 $\mu$ A	
RTD input	XBF-RD04A	4	PT100	0.1 $^{\circ}$ C	1. External DC24V used 2. Filter function
	XBF-RD01A	1	JPT100		
Thermocouple Input module	XBF-TC04S	4	K / J / T / R	Note1)	1. External DC24V used 2. Filter function, average function
	XBF-TC04B				

Note1) for more detail on thermocouple input module resolution, refer to Ch.5.2.6 accuracy/resolution.

Classification	Name	No. of channel	Range	Resolution	Characteristic
Analog Input/Output (voltage/current I/O)	XBF-AH04A	2(Input) 2(Output)	4~20mA 0~20mA	5.0 $\mu$ A	1.Range selection by external switch and parameter setting 2.Filter function, averaging function 3.Specifies output when error or CPU STOP 4. Uses external DC24V
			1~5V 0~5V	1.25 mV	
			0~10V	2.5 mV	
Analog Input Option Board	XBO-AD02A	2	4~20mA	6.25 $\mu$ A	1. Parameter setting 2. Filter function, average function 3. Internal VDD 5V
Analog Output Option Board	XBO-DA02A	2	0~20mA	5.0 $\mu$ A	
			0~10V	2.5 mV	
Analog IO Option Board	XBO-AH02A	1(Input)	4~20mA	6.25 $\mu$ A	1. Parameter setting 2. Filter function, average function 3. Internal VDD 5V
			0~20mA	5.0 $\mu$ A	
		1(Output)	0~10V	2.5 mV	
RTD Input Option Board	XBO-RD01A	1	PT100 JPT100	0.1 $^{\circ}$ C	1. Internal VDD 5V 2. Filter function, average function
Thermocouple Input Option Board	XBO-TC02A	2	K / J	Note2)	1. Internal VDD 5V 2. Filter function, average function

Note2) for more detail on Thermocouple Input Option Board resolution, refer to Ch.12.5 accuracy

## 1.2 Specification of Analog Module

Here describes about specification of analog module of XGB series.

### 1.2.1 Analog input

Item		XBF-AD04A		
Analog input range	Type	Voltage	Current	
	Range	DC 0 ~ 10V (Input resistance: 1 MΩ min.)	DC 4 ~ 20mA DC 0 ~ 20mA (Input resistance: 250 Ω)	
Digital output	Type	12 bit binary data		
	Range	Unsigned value	0 ~ 4000	
		Signed value	-2000 ~ 2000	
		Precise value	0 ~ 1000	400 ~ 2000/0 ~ 2000
Percentile value		0 ~ 1000		
Max. resolution		2.5mV (1/4000)	5μA (1/4000)	
Accuracy		± 0.5% or less		
Max. conversion speed		1.5ms/channel		
Absolute max. input		DC ±15V	DC +25mA	
No. of output channel		4 channels		
Insulation method		Photo-coupler insulation between input terminal and PLC power (No insulation between channels)		
Connection Terminal		11 point terminal block		
I/O points occupied		Fixed type: 64 points		
Max. number of equipment		7 [When using XBM-Dxxx□ (□: "S", "H", "H2", "HP") type] 7 (when using XB(E)C-DxxxSU type) 10 (when using XB(E)C-DxxxH type or XB(E)C-DxxxU type) Not Available (when using XB(E)C-DxxxE type)		
Consumption current	Inner (DC 5V)	120mA		
	External (DC 24V)	62mA		
Weight		64g		
Additional function		Filter-processing, average-processing (time, count)		

Items		XBF-AD04C	
Number of channels		4 channels	
Analog input	Type	Voltage	Current
	Range	DC 1 ~ 5V DC 0 ~ 5V DC 0 ~ 10V DC -10 ~ 10V (Input resistance: 1 M $\Omega$ min)	DC 4 ~ 20mA DC 0 ~ 20mA (Input resistance: 250 $\Omega$ )
		Current input or Voltage input can be selected through the external terminal wiring setting. ▶ In voltage mode, use V+ and COM terminal for the channel. In current mode, short V+ and COM terminal and then use I+ and COM terminal.	
Digital output	Type	16 bit binary data (Data : 14Bit)	
	Range	Unsigned value	0 ~ 16,000
		Signed value	-8,000 ~ 8,000
		Precise value	1,000 ~ 5,000 (1 ~ 5V) 0 ~ 5,000 (0 ~ 5V) 0 ~ 10,000 (0 ~ 10V) -10,000 ~ 10,000 ( $\pm$ 10V)
Percentile value		0 ~ 10,000	
Max. resolution		1/16,000	
		0.250mV (1 ~ 5V) 0.3125mV (0 ~ 5V) 0.625mV (0 ~ 10V) 1.250mV ( $\pm$ 10V)	1.0 $\mu$ A (4 ~ 20mA) 1.25 $\mu$ A (0 ~ 20mA)
Accuracy		$\pm$ 0.2% or less (When ambient temperature 25 $^{\circ}$ C) $\pm$ 0.3% or less (When ambient temperature 0 ~ 55 $^{\circ}$ C)	
Max. conversion speed		1ms/ channel	
Absolute max. input		DC $\pm$ 15V	DC $\pm$ 30mA
Addition function	Filter	Digital filter(4 ~ 64,000ms)	
	Average	Time average (4~16,000ms)	
		Count average (2~64,000times)	
	Detection alarm	Disconnection(DC 1~5V, DC 4~20mA)	
	Hold last value	When input signal exceeds the effective range, holds the last effective value.	
Alarm function	When input signal exceeds the effective range, relevant flag turns on.		
Insulation method		Photo-coupler insulation between input terminal and PLC power (No insulation between channels)	
Connection terminal		15 point terminal block	
I/O points occupied		Fixed type assignment: 64	
Max. attachable number		7 [When using XBM-Dxxx□ (□: "S", "H", "H2", "HP") type] 7 (when using XB(E)C-DxxxSU type) 10 (when using XB(E)C-DxxxH type or XB(E)C-DxxxU type) Not Available (when using XB(E)C-DxxxE type)	
Consumption current	Internal (DC 5V)	110mA	
	External (DC 24V)	100mA	
Weight		72g	
Module input power		DC 20.4~28.8V	

Item		XBF-AD08A		
Analog input range	Type	Voltage	Current	
	Range	DC 1 ~ 5V DC 0 ~ 5V DC 0 ~ 10V (Input resistance: 1 MΩ min.)	DC 4 ~ 20mA DC 0 ~ 20mA (Input resistance: 250 Ω)	
		Input range can be voltage/current selector switch after being set by user program or I/O parameter for each channel		
Digital output	Type	12 bit binary data		
	Range	Unsigned value	0 ~ 4000	
		Signed value	-2000 ~ 2000	
		Precise value	100 ~ 500 (DC 1 ~ 5V) 0 ~ 500 (DC 0 ~ 5V) 0 ~ 1000 (DC 0 ~ 10V)	400 ~ 2000 (DC 4 ~ 20mA) 0 ~ 2000 (DC 0 ~ 20mA)
		Percentile value	0 ~ 1000	
Max. resolution		1/4000		
		1.25mV (DC 1~5V, 0~5V) 2.5mV (DC 0~10V)	5μA (DC4~20mA, 0~20mA)	
Accuracy		± 0.5% or less		
Max. conversion speed		1.5ms/channel		
Absolute max. input		DC ±15V	DC +25mA	
No. of output channel		8 channels		
Insulation method		Photo-coupler insulation between input terminal and PLC power (No insulation between channels)		
Connection Terminal		11 point terminal block		
I/O points occupied		Fixed type: 64 points		
Max. number of equipment		7 [When using XBM-Dxxx□ (□: "S", "H", "H2", "HP") type] 7 (when using XB(E)C-DxxxSU type) 10 (when using XB(E)C-DxxxH type or XB(E)C-DxxxU type) Not Available (when using XB(E)C-DxxxE type)		
Additional function	Filter function	Digital filter (4~64,000ms)		
	Average function	Time average (4~16,000ms)		
		Count average (2~64,000 times)		
		Moving average (2~100)		
Alarm function	Disconnection detection (DC 1~5V, DC 4~20mA)			
Consumption current	Inner (DC 5V)	105mA		
	External (DC 24V)	85mA		
Weight		81g		

## 1.2.2 Analog output

Item		XBF-DV04A	XBF-DC04A	XBF-DC04B	
Analog output	Type	Voltage	Current	Current	
	Range	DC 0 ~ 10V (Load resistance: 2k $\Omega$ or more)	DC 4 ~ 20mA DC 0 ~ 20mA (Load resistance: 510 $\Omega$ or less)	DC 0 ~ 1.2mA (Load resistance: 510 $\Omega$ or less)	
Digital input	Type		12-bit binary data		
	Range	Signed value	0 ~ 4000	0 ~ 4000	0 ~ 4000
		Unsigned value	-2000 ~ 2000	-2000 ~ 2000	-2000 ~ 2000
		Precise value	0 ~ 1000	400 ~ 2000/0 ~ 2000	0 ~ 1,200
		Percentile value	0 ~ 1000	0 ~ 1000	0 ~ 1,000
Maximum resolution		2.5mV (1/4000)	5 $\mu$ A (1/4000)	0.3 $\mu$ A (1/4000)	
Accuracy		$\pm$ 0.5% or less			
Maximum conversion speed		1 ms/channel			
Absolute maximum output		DC $\pm$ 15V	DC +25mA		
Number of maximum channel		4 channels			
Insulation method		Photo-coupler insulation between input terminal and PLC power (no insulation between channels)			
Terminal connected		11-point terminal block			
I/O points occupied		Fixed type: 64 points			
Max. no. of installation		7 [When using XBM-Dxxx□ (□:"S", "H", "H2", "HP") type] 7 (when using XB(E)C-DxxxSU type) 10 (when using XB(E)C-DxxxH type or XB(E)C-DxxxU type) Not Available (when using XB(E)C-DxxxE type)			
Current consumption	Internal (DC 5V)	110mA	110mA		
	External (DC 24V)	70mA	120mA		
Weight		64g	70g		



Items		XBF-DV04C	XBF-DC04C	
Channels		4 channels		
Analog output range	Type	Voltage		
	Range	DC 1 ~ 5V DC 0 ~ 5V DC 0 ~ 10V DC -10 ~ 10V (Load resistance: 1k $\Omega$ or more)	DC 4 ~ 20mA DC 0 ~ 20mA (Load resistance: 600 $\Omega$ or less)	
	Output ranges are set in user program or I/O parameter per each channel.			
Digital input	Type	16 bit binary data (Data : 14Bit)		
	Range	Unsigned value	0 ~ 16,000	
		Signed value	-8,000 ~ 8,000	
		Precise value	1,000 ~ 5,000 (1 ~ 5V) 0 ~ 5,000 (0 ~ 5V) 0 ~ 10,000 (0 ~ 10V) -10,000 ~ 10,000 ( $\pm$ 10V)	4,000 ~ 20,000 (4 ~ 20mA) 0 ~ 20,000 (0 ~ 20mA)
		Percentile value	0 ~ 10,000	
Max. resolution		1/16,000		
		0.250mV (1 ~ 5V) 0.3125mV (0 ~ 5V) 0.625mV (0 ~ 10V) 1.250mV ( $\pm$ 10V)	1.0 $\mu$ A (4 ~ 20mA) 1.25 $\mu$ A (0 ~ 20mA)	
Accuracy		$\pm$ 0.2% or less (When ambient temperature is 25 $^{\circ}$ C) $\pm$ 0.3% or less (When ambient temperature is 0 ~ 55 $^{\circ}$ C)		
Max. conversion speed		1ms/ channel		
Additional function		Setting of channel output status (Select one among previous, Min, Max value) Setting of interpolation method (Linear interpolation, S-type interpolation)		
Insulation method		Photo-coupler insulation between output terminal and PLC power (no insulation between channels)		
Terminal connected		11 point terminal		
I/O occupied points		Fixed point assignment: 64 points		
Max. attachable number		7 [When using XBM-Dxxx $\square$ ( $\square$ : "S", "H", "H2", "HP") type] 7 (when using XB(E)C-DxxxSU type) 10 (when using XB(E)C-DxxxH type or XB(E)C-DxxxU type) Not Available (when using XB(E)C-DxxxE type)		
Weight		68g	69g	
Consumed current	Internal (DC 5V)	75mA		
	External (DC 24V)	170mA		
Power Supply		DC 20.4V ~ 28.8V		

## 1.2.3 RTD input

Item		XBF-RD04A	XBF-RD01A
No. of input channel		4 channels	One channel
Input sensor type	PT100	JIS C1604-1997	
	JPT100	JIS C1604-1981 , KS C1603-1991	
Temperature input range	PT100	-200 ~ 600°C	
	JPT100	-200 ~ 600°C	
Digital output	PT100	-2000 ~ 6000	
	JPT100	-2000 ~ 6000	
	Scaling display	0 ~ 4000	
Accuracy	Normal temp.(25°C)	Within $\pm 0.3\%$	
	Full temp.(0~55°C)	Within $\pm 0.5\%$	
Conversion speed		40ms / channel	
Insulation	Channel to Channel	Non-insulation	
	Terminal to PLC Power	Insulation (Photo-Coupler)	
Terminal block		15-point terminal block	
I/O points occupied		Fixed type: 64 points	
Wiring method		3-wire	
Max. number of equipment		7 [When using XBM-Dxxx□ (□:"S", "H", "H2", "HP") type] 7 (when using XB(E)C-DxxxSU type) 10 (when using XB(E)C-DxxxH type or XB(E)C-DxxxU type) Not Available (when using XB(E)C-DxxxE type)	
Function	Filtering	Digital filter (160 ~ 64000ms)	
	Alarm	Disconnection detection	
Current consumption	Inner DC5V	100mA	
	external DC24V	100mA	
Weight		63g	

## 1.2.4 Thermocouple input

(1) Thermocouple input specification (XBF-TC04S / XBF-TC04B)

Items		Specification
Number of input channel		4 channels Select channel type by parameter (thermocouple input)
Type of input sensor		Thermocouple K / J / T / R type JIS C1602-1995
Range of input temperature	K	-200.0°C ~ 1300.0°C
	J	-200.0°C ~ 1200.0°C
	T	-200.0°C ~ 400.0°C
	R	0.0°C ~ 1700.0°C
Digital output	Temp. display	Displaying down to one decimal place – note1) K, J, T type: 0.1°C, R type: 0.5°C
	Scaling display (user-defined scaling)	Unsigned scaling (0 ~ 65535)
		Signed scaling (-32768 ~ 32767)
Accuracy	Ambient temperature(25°C)	Within ±0.2% – note 2)
	Temp. coefficient (range of operating temp)	±100 ppm/°C
Conversion time		50ms / channel
Reference junction compensation	Auto compensation by RJC sensing (Thermistor)	
	Compensation amount	±1.0°C
Warming-up time		15 min or above –note 3)

Note1), Note2) For more detail specification, refer to 5.2.6 accuracy/resolution.

Note 3) Warming-up time: for stability of measured temperature, 15 min is necessary after power is on.

(2) Voltage input specification (XBF-TC04B)

Items		Specification
Number of input channel		4 channels Select channel type by parameter (thermocouple/voltage input)
Analog input range		0 ~ 100 mV (Input impedance: 1MΩ or above)
Digital output	Type	0 ~ 20000
	Scaling display (user-defined scaling)	Unsigned scaling (0 ~ 65535)
		Signed scaling (-32768 ~ 32767)
Max. resolution		1/20000 (0.005mV)
Accuracy	Ambient temperature (25°C)	Within ±0.2%
	Temp. coefficient (operating temp. range)	±100 ppm/°C
Conversion time		50ms / channel

## (3) Common specification (XBF-TC04S / XBF-TC04B)

Items		Specification	
Insulation	Insulation method	Terminal – inner circuit	Photo-coupler insulation
		Terminal – operating power	DC/DC converter insulation
		Between channels	Photomos relay insulation
	Dielectric withstand voltage		400 V AC, 50/60 Hz, 1min, leakage current 10mA or below
	Insulation resistance		500 V DC, 10 MΩ or below
Terminal block		11 point terminal	
I/O occupied points		64 points	
Max. number of equipment		7 [When using XBM-Dxxx□ (□: "S", "H", "H2", "HP") type] 7 (when using XB(E)C-DxxxSU type) 10 (when using XB(E)C-DxxxH type or XB(E)C-DxxxU type) Not Available (when using XB(E)C-DxxxE type)	
Additional function	Filter process		Digital filter (200 ~ 64,000ms)
	Average process	Time average (400~64,000ms)	
		Count average (2~64,000 times)	
		Moving average (2~100)	
	Alarm		Disconnection detection
	Max./Min. display		Display Max./Min.
Scaling function		Signed scaling / Unsigned scaling	
Consumption current	Inner DC5V		100mA
	External DC24V		100mA
Weight		63g	

## 1.2.5 Analog Input/Output

### (1) Input performance specification

Items		XBF-AH04A		
No. of input channel		2 channels		
Analog input range	Type	Voltage	Current	
	Range	DC 1 ~ 5V	DC 4 ~ 20mA	
		DC 0 ~ 5V	DC 0 ~ 20mA	
		DC 0 ~ 10V (input resistor: 1 MΩ or above)	(input resistor 250 Ω)	
		Input range can be set through external voltage/current selector switch after setting at user program or I/O parameter per input channel		
Digital output	Type	12bit binary data		
	Range	Unsigned value	0 ~ 4000	
		Signed value	-2000 ~ 2000	
		Precise value	100 ~ 500 (DC 1 ~ 5V)	400 ~ 2000 (DC 4 ~ 20mA)
			0 ~ 500 (DC 0 ~ 5V)	0 ~ 2000 (DC 0 ~ 20mA)
0 ~ 1000 (DC 0 ~ 10V)				
Percentile value	0 ~ 1000			
Max. resolution		1/4000		
		1.25mV (DC 1~5V, 0~5V)	5μA (DC4~20mA, 0~20mA)	
		2.5mV (DC 0~10V)		
Precision		±0.5% or less		
Max. conversion speed		1ms/channel		
Absolute max. input		DC ±15V	DC ±25mA	
Additional function	Filter function	Digital filter (4 ~ 64,000ms)		
	Averaging function	Time averaging (4~16,000ms)		
		Cyclic averaging (2~64,000cycle)		
		Moving averaging (2~100samples)		
Alarm function	Disconnection detection (DC 1~5V, DC4~20mA)			

**(2) Output performance specification**

Items		XBF-AH04A		
No. of output channel		2 channels		
Analog output range	Type	Voltage	Current	
	Range	DC 1 ~ 5V	DC 4 ~ 20mA	
		DC 0 ~ 5V	DC 0 ~ 20mA	
		DC 0 ~ 10V (Load resistor: 2kΩ or above)	(Load resistor 510 Ω or less)	
		Input range can be set through external voltage/current selector switch after setting at user program or I/O parameter per input channel		
Digital input	Type	12 bit binary data		
	Range	Unsigned value	0 ~ 4000	
		Signed value	-2000 ~ 2000	
		Precise value	100 ~ 500 (DC 1 ~ 5V)	400 ~ 2000 (DC 4 ~ 20mA)
			0 ~ 500 (DC 0 ~ 5V)	0 ~ 2000 (DC 0 ~ 20mA)
0 ~ 1000 (DC 0 ~ 10V)				
Percentile value	0 ~ 1000			
Max. resolution		1/4000		
		1.25mV (DC 1~5V, 0~5V)	5μA (DC4~20mA, 0~20mA)	
		2.5mV (DC 0~10V)		
Precision		±0.5% or less		
Max. conversion speed		1ms/channel		
Absolute max. output		DC ±15V	DC 25mA	
Additional function		Function setting channel output status (Can select one among Previous, Minimum, median, maximum)		

**(3) I/O common performance specification**

Items		XBF-AH04A	
Insulation method		Photo coupler insulation between I/O terminal and PLC power (not insulated between channels)	
I/O terminal block		11 points terminal block	
No. of I/O occupation point		Fixed type: 64 points	
Max. number of equipment		7 [When using XBM-Dxxx□ (□:"S","H","H2","HP") type] 7 (when using XB(E)C-DxxxSU type) 10 (when using XB(E)C-DxxxH type or XB(E)C-DxxxU type) Not Available (when using XB(E)C-DxxxE type)	
Consumption current	Internal (DC 5V)	120mA	
	External (DC 24V)	130mA	
Weight		73g	

## 1.2.6 Analog Input Option Board

Items		XBO-AD02A		
Number of channel		2 channels		
Analog input range	Type	Voltage	Current	
	Range	DC 0 ~ 10V (Input resistance: 1 M $\Omega$ or above)	DC 4 ~ 20mA DC 0 ~ 20mA (Input resistance 250 $\Omega$ )	
		Set by external voltage/current selector switch after being set at user program or I/O parameter per each channel		
Digital output	Type	12 bit binary data		
	Range	Unsigned value	0 ~ 4000	
		Signed value	-2000 ~ 2000	
		Precise value	0 ~ 1000 (DC 0 ~ 10V)	400 ~ 2000 (DC 4 ~ 20mA) 0 ~ 2000 (DC 0 ~ 20mA)
Percentile value		0 ~ 1000		
Max. resolution		1/4000 (DC 4~20mA: 1/3200)		
		2.5mV (DC 0~10V)	5 $\mu$ A (DC 0~20mA) 6.25 $\mu$ A (DC 4 ~ 20mA)	
Accuracy		$\pm$ 1.0% or less		
Max. conversion speed		1ms/channel + scan time		
Absolute max. input		DC +12V / -10V	DC $\pm$ 25mA	
Additional function	Average function	Count average (2 ~ 64,000 times)		
	Gain adjustment function	Gain adjustment (-40~40)		
Insulation method		No insulation between channels No insulation between input terminal and PLC main unit		
Input terminal		5 - point terminal block		
I/O points occupied		Fixed type: 64 points		
Max. no. of installation		1 (when using XBC-DR10E/DR14E type) 2 (when using XBC-DR20E/DR30E type) 2 (when using XBC-DxxxS/SU type)		
Supply power		Internal DC 5V		
Consumption current		50mA		
Weight		20g		

## 1.2.7 Analog Output Option Board

Item		XBO-DA02A	
No. of channels		2 channels	
Analog output range	Type	Voltage	Current
	Range	DC 0 ~ 10V (Load resistance: 2k $\Omega$ or more)	DC 4 ~ 20mA DC 0 ~ 20mA (Load resistance: 450 $\Omega$ )
		Output range can be set at user program or I/O parameter for each channel	
Digital input	Type		12-bit binary data
	Range	Unsigned value	0~4000
		Signed value	-2000 ~ 2000
		Precise value	0 ~ 1000 (DC0~10V)      400 ~ 2000 (DC4~20mA) 0 ~ 2000 (DC0~20mA)
		Percentile value	0 ~ 1000
Maximum resolution		1/4000 (DC 4 ~ 20mA: 1/3200)	
Accuracy		$\pm 1.0\%$ or less	
Maximum conversion speed		1ms/channel + scan time	
Additional function		Channel output state setting (former, min, middle, max value) Gain adjustment function	
Insulation method		no insulation between analog output channels no insulation between output terminal and PLC main unit	
I/O terminal		5-point terminal block	
Power supply		Internal 5V	
I/O points occupied		Fixed type: 64 points	
Supply power		Internal DC5V	
Current consumption		150mA	
Weight		20g	



## 1.2.8 Analog I/O Option Board

### (1) Input performance specification

Items		XBO-AH02A	
Number of channels		1 channel	
Analog input range	Type	Voltage	Current
	Range	DC 0 ~ 10V (Input resistance: 1M $\Omega$ or above)	DC 4 ~ 20mA DC 0 ~ 20mA (Input resistance: 250 $\Omega$ )
		Set by external voltage/current wiring after being set at user program or I/O parameter per each channel	
Digital output	Type	12 bit binary data	
	Range	Unsigned value	0 ~ 4000
		Signed value	-2000 ~ 2000
		Precise value	0 ~ 1000 (DC 0 ~ 10V)      400 ~ 2000 (DC 4 ~ 20mA) 0 ~ 2000 (DC 0 ~ 20mA)
Percentile value		0 ~ 1000	
Max. resolution		1/4000 (DC 4~20mA: 1/3200)	
		2.5mV (DC 0~10V)	5 $\mu$ A (DC 0~20mA) 6.25 $\mu$ A (DC 4~20mA)
Accuracy		$\pm$ 1.0% or less	
Max. conversion speed		1ms/channel + scan time	
Absolute max. input		DC +12V / -10V	DC $\pm$ 25mA
Additional function	Average function	Count average (2 ~ 64,000 times)	
	Gain adjustment function	Gain adjustment (-40~40)	

### (2) Output performance specification

Items		XBO-AH02A	
Number of channels		1 channel	
Analog output range	Type	Voltage	Current
	Range	DC 0 ~ 10V (Load resistance: 2k $\Omega$ or above)	DC 4 ~ 20mA DC 0 ~ 20mA (Load resistance: 450 $\Omega$ )
		Set at user program or I/O parameter per each channel per each channel	
Digital input	Type	12 bit binary data	
	Range	Unsigned value	0 ~ 4000
		Signed value	-2000 ~ 2000
		Precise value	0 ~ 1000 (DC 0 ~ 10V)      400 ~ 2000 (DC 4 ~ 20mA) 0 ~ 2000 (DC 0 ~ 20mA)
Percentile value		0 ~ 1000	
Max. resolution		1/4000 (DC 4 ~ 20mA: 1/3200)	
		2.5mV (DC 0~10V)	5 $\mu$ A (DC 0~20mA) 6.25 $\mu$ A (DC 4~20mA)
Accuracy		$\pm$ 1.0% or less	
Max. conversion speed		1ms/channel + scan time	
Additional function		CH output status setting(select among former, min, middle, max value) Gain adjustment function	

**(3) I/O Common performance specification**

Items	XBO-AH02A
Insulation method	Non-insulation between analog I/O channels Non-insulation between I/O terminal and PLC main unit
I/O terminal	5-point terminal block
I/O occupation point	Fixed type: 64 points
Max. installation count	1 (when using XBC-DR10E/DR14E type) 2 (when using XBC-DR20E/DR30E type) 2 (when using XBC-DxxxS/SU type)
Supply power	Internal DC5V
Consumption current	150mA
Weight	20g

## 1.2.9 RTD Input Option Board

Items		XBO-RD01A
No. of input channels		One channel
Input sensor type	PT100	JIS C1604-1997
	JPT100	JIS C1604-1981 , KS C1603-1991
Temperature input range	PT100	-200 ~ 600℃
	JPT100	-200 ~ 600℃
Digital output	PT100	-2000 ~ 6000
	JPT100	-2000 ~ 6000
Accuracy		Within $\pm 1.0\%$
Conversion speed		25m/1 channel
Insulation	Channel to Channel	Non-insulation
	Terminal to PLC Power	Insulation (Photo-Coupler)
Terminal block		5-point terminal block
I/O points occupied		Fixed type: 64 points
Max. number of equipment		1 (when using XBC-DR10E/DR14E type) 2 (when using XBC-DR20E/DR30E type) 2 (when using XBC-DxxxS type)
Wiring method		3-wire type
Function	Averaging	Count averaging function
	Alarm	Disconnection detection
Supply power		Internal DC5V
Consumption current		30mA
Weight		20g

## 1.2.10 Thermocouple Input Option Module

Items		XBO-TC02A
Number of input channel		2 channels
Type of input sensor		Thermocouple K / J type (JIS C1602-1995)
Range of input temperature	K type sensor	-200.0°C ~ 1300.0°C
	J type sensor	-200.0°C ~ 1200.0°C
Digital output	Temp. display unit	16 bit binary data Displaying down to one decimal place (K, J, type: 0.1°C)
Accuracy		±1.0% or less
Conversion speed		50ms/2channelles –note1)
Reference junction compensation	Auto compensation by RJC sensing (Thermistor)	
	Compensation amount	±1.0°C
Additional function	Average process	Count averaging
	Alarm	Input disconnection detection
Warming-up time		15 min or above – note2)
Insulation method		Non-insulation between input channels Non-insulation between input terminal and PLC main unit
I/O terminal		5-point terminal block
Max. number of equipment		1 (when using XBC-DR10E/DR14E type) 2 (when using XBC-DR20E/DR30E type) 2 (when using XBC-DxxxS type)
Supply power		Internal DC5V
I/O occupied points		Fixed type: 64 points
Consumption current		50mA
Weight		20g

## Chapter 2 Analog Input Module

### 2.1 Setting Sequence before operation

Before using the analog input module, follow steps below.

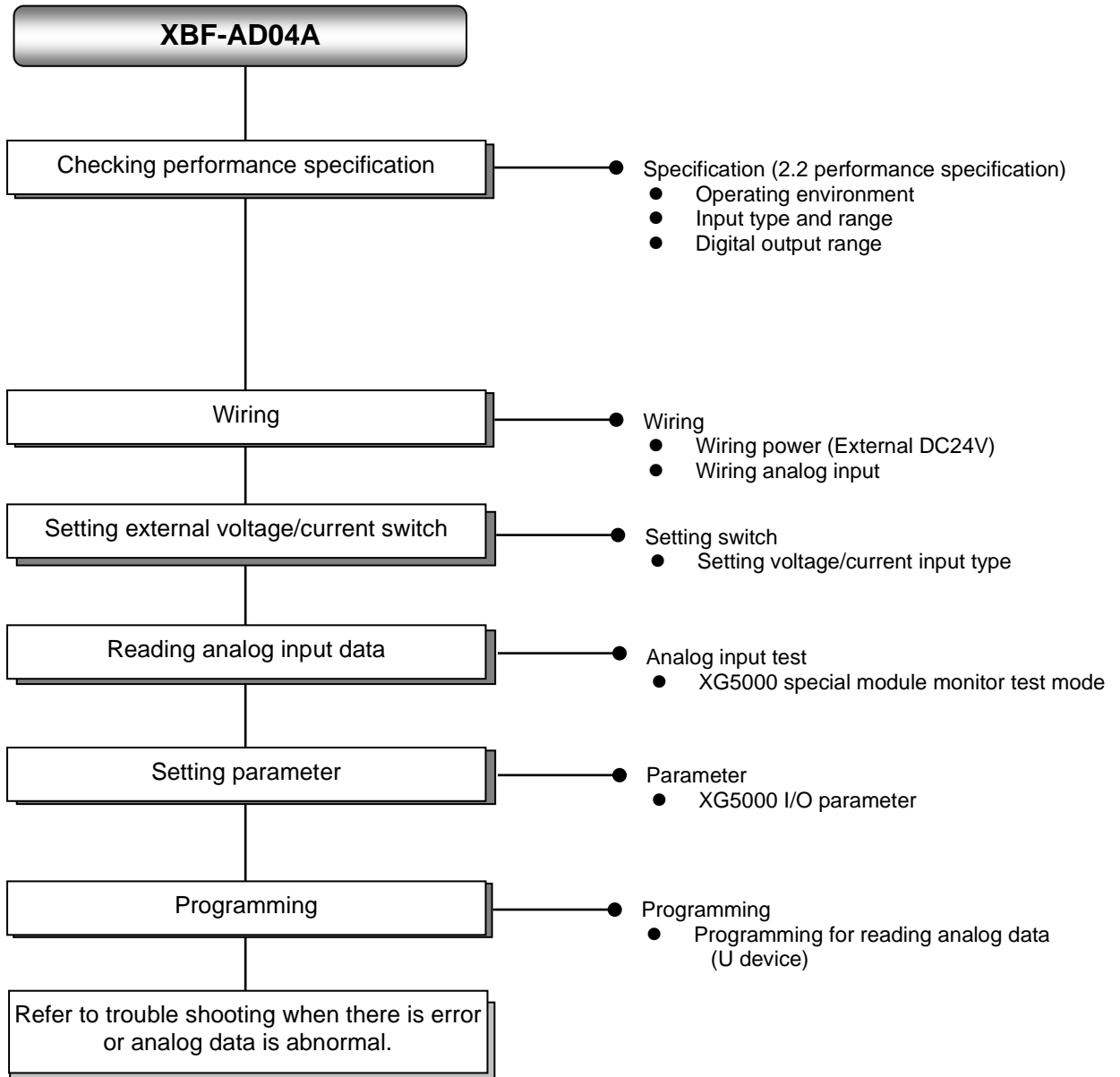

## 2.2 Specifications

### 2.2.1 General specifications

General specifications are as follows.

No.	Item	Specifications	Related specifications			
1	Ambient temperature	0°C ~ +55°C	-			
2	Storage temperature	-25°C ~ +70°C	-			
3	Ambient humidity	5 ~ 95%RH (Non-condensing)	-			
4	Storage humidity	5 ~ 95%RH (Non-condensing)	-			
5	Vibration resistance	Occasional vibration		-	IEC61131-2	
		Frequency	Acceleration	Amplitude		How many times
		5 ≤ f < 8.4 Hz	-	3.5 mm		10 times each directions (X, Y and Z)
		8.4 ≤ f ≤ 150 Hz	9.8 m/s <sup>2</sup> (1G)	-		
		For continuous vibration				
		Frequency	Acceleration	Amplitude		
		5 ≤ f < 8.4 Hz	-	1.75 mm		
8.4 ≤ f ≤ 150 Hz	4.9 m/s <sup>2</sup> (0.5G)	-				
6	Shock resistance	<ul style="list-style-type: none"> <li>Peak acceleration: 147 m/s<sup>2</sup>(15G)</li> <li>Duration: 11ms</li> <li>Half-sine, 3 times each direction per each axis</li> </ul>	IEC61131-2			
7	Noise resistance	Square wave Impulse noise	AC: ± 1,500V DC: ± 900V	LSIS standard		
		Electrostatic discharge	Voltage : 4kV (contact discharging)	IEC 61131-2, IEC 61000-4-2		
		Radiated electromagnetic field noise	80 ~ 1,000 MHz, 10V/m	IEC 61131-2, IEC 61000-4-3		
		Fast transient /bust noise	Segment Voltage	Power supply module 2kV	Digital/analog input/output communication interface 1kV	IEC 61131-2, IEC 61000-4-4
8	Environment	Free from corrosive gasses and excessive dust	-			
9	Altitude	Up to 2,000 ms	-			
10	Pollution degree	Less than equal to 2	-			
11	Cooling	Air-cooling	-			

### 2.2.2 Performance specifications

Performance specifications are as follows.

Items		XBF-AD04A		
Analog input range	Type	Voltage	Current	
	Range	DC 0 ~ 10V (Input resistance: 1 MΩ min.)	DC 4 ~ 20mA DC 0 ~ 20mA (Input resistance 250 Ω)	
Digital output	Type	12 bit binary data		
	Range	Unsigned value	0 ~ 4000	
		Signed value	-2000 ~ 2000	
		Precise value	0 ~ 1000	400 ~ 2000/0 ~ 2000
		Percentile value	0 ~ 1000	
Max. resolution		2.5mV(1/4000)	5μA(1/4000)	
Accuracy		±0.5% or less		
Max. conversion speed		1.5ms/channel		
Absolute max. output		DC ±15V	DC ±25mA	
No. of output channel		4 channels		
Insulation method		Photo-coupler insulation between input terminal and PLC power (No insulation between channels)		
Connection terminal		11 point terminal block		
I/O points occupied		Fixed type: 64 points		
Max. no of installation		7 [When using XBM-Dxxx□ (□:"S","H","H2","HP") type] 7 (when using XB(E)C-DxxxSU type) 10 (when using XB(E)C-DxxxH type or XB(E)C-DxxxU type) Not Available (when using XB(E)C-DxxxE type)		
Consumption current	Inner (DC 5V)	120mA		
	External (DC 24V)	62mA		
Weight		64g		
Additional function		Filter-processing, average-processing (time, count)		

#### Notes

- 1) When A/D conversion module is released from the factory, Offset/Gain value is as adjusted for respective analog input ranges, which is unavailable for user to change.
- 2) Offset Value: Analog input value where digital output value is 0 when digital output format is set to Unsigned Value.
- 3) Gain Value: Analog input value where digital output value is 16000 when digital output format is set to Unsigned Value.

## 2.3 Name of part and function

Respective designations of the parts are as described below.

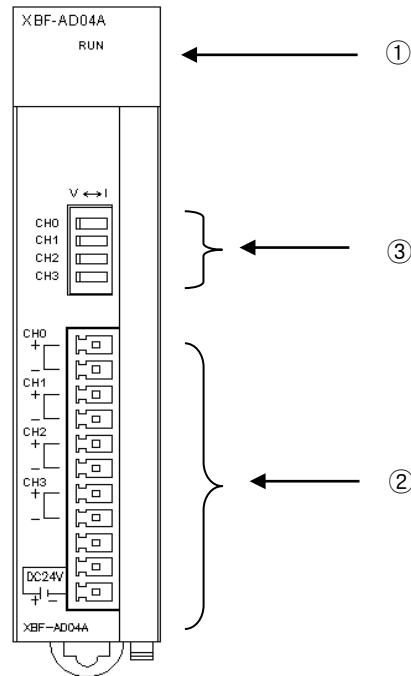

No.	Description
①	RUN LED
	<ul style="list-style-type: none"> <li>▪ Displays the operation status of XBF-AD04A</li> <li>On: Operation normal</li> <li>Flickering: Error occurs (page 12-30)</li> <li>Off: Module error</li> </ul>
②	Terminal block
	<ul style="list-style-type: none"> <li>▪ Analog input terminal, whose respective channels can be connected with external devices.</li> </ul>
③	Voltage/Current selection switch
	<ul style="list-style-type: none"> <li>▪ Switch for voltage and current selection of analog input</li> </ul>



## 2.4 Characteristic of I/O conversion

Characteristics of I/O conversion are the inclination connected in a straight line between Offset and Gain values when converting analog signal (voltage or current input) from PLC's external device to digital value. I/O conversion characteristics of A/D conversion modules are as described below.

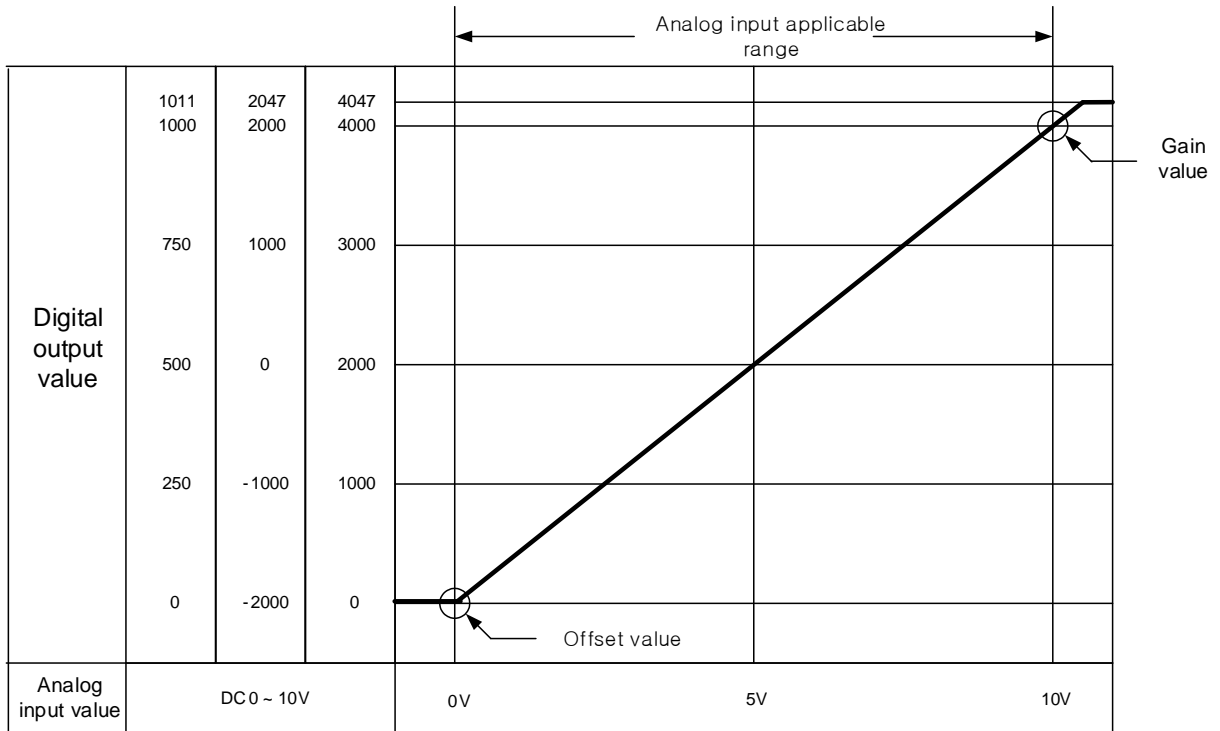

## 2.5 Conversion Characteristic according to Input Range

Voltage input range can be set through user program or special module package for respective channels. Output formats of digital data are as specified below;

- A. Unsigned Value
- B. Signed Value
- C. Precise Value
- D. Percentile Value

### 2.5.1 If the range is DC 0 ~ 10V

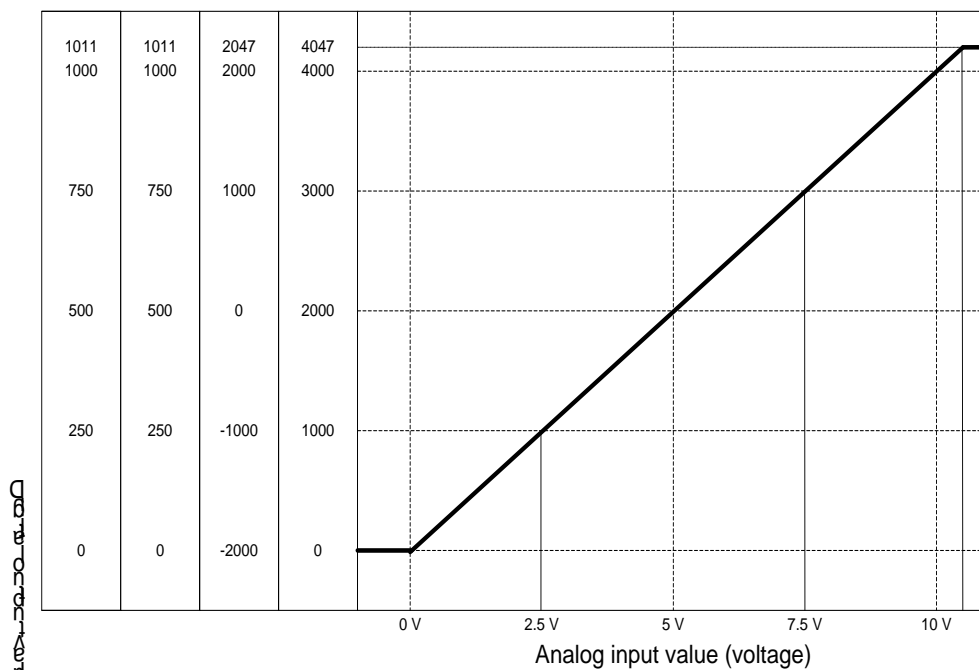

Digital output value for voltage input characteristic is as specified below.  
 (Resolution (based on 1/4000): 2.5 mV)

Digital output range	Analog input voltage (V)					
	0	2.5	5	7.5	10	10.11
Unsigned value (0 ~ 4047)	0	1000	2000	3000	4000	4047
Signed value (-2000 ~ 2047)	-2000	-1000	0	1000	2000	2047
Precise value (0 ~ 1011)	0	250	500	750	1000	1011
Percentile value (0 ~ 1011)	0	250	500	750	1000	1011

2.5.2 If the range is DC 0 ~ 20mA

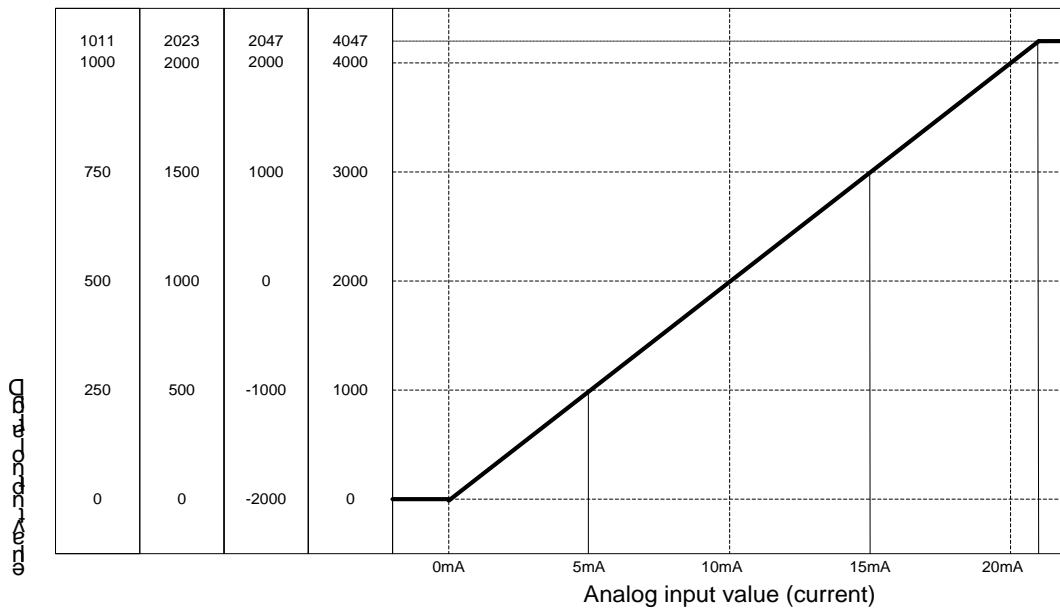

- Digital output value for current input characteristic is as specified below.  
(Resolution (based on 1/4000): 5  $\mu$ A)

Digital output range	Analog input current (mA)					
	0	5	10	15	20	20.23
Unsigned value (0 ~ 4047)	0	1000	2000	3000	4000	4047
Signed value (-2000 ~ 2047)	-2000	-1000	0	1000	2000	2047
Precise value (0 ~ 2023)	0	500	1000	1500	2000	2023
Percentile value (0 ~ 1011)	0	250	500	750	1000	1011

2.5.3 If range is DC4 ~ 20mA

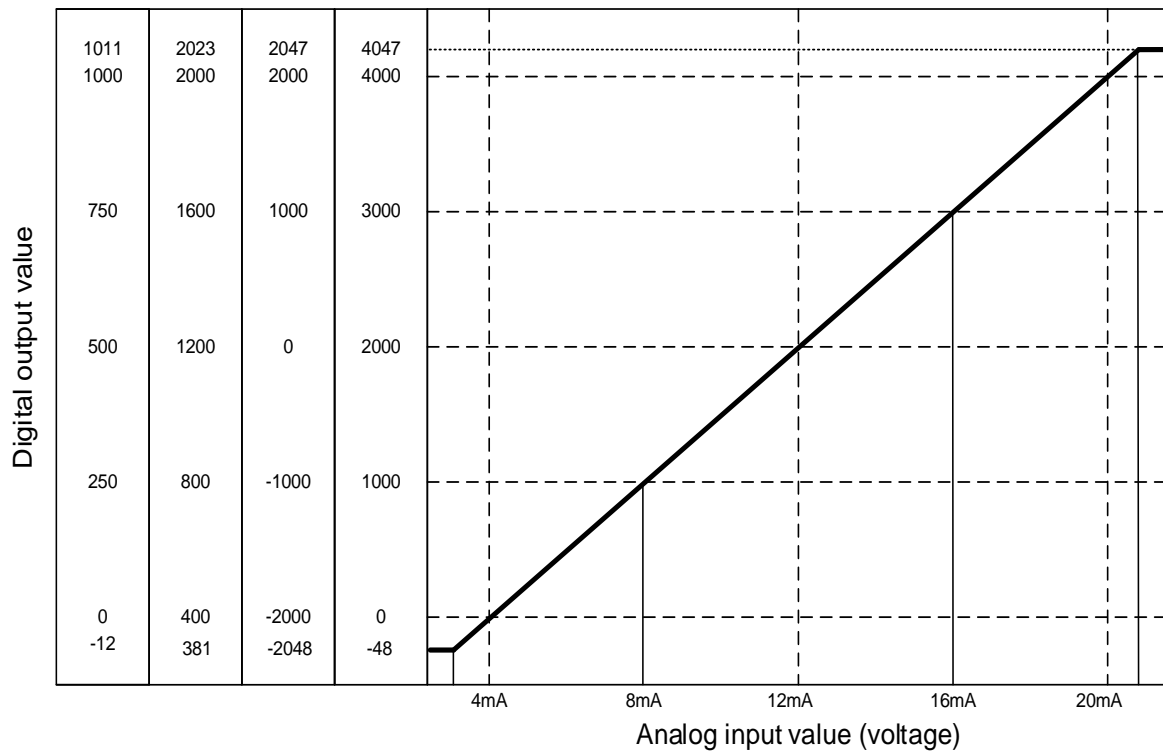

- Digital output value for current input characteristic is as specified below.  
(Resolution (Based on 1/4000): 5  $\mu\text{A}$ )

Digital Output range	Analog input current (mA)						
	0	4	8	12	16	20	20.23
Unsigned value (-48 ~ 4047)	-48	0	1000	2000	3000	4000	4047
Signed value (-2048 ~ 2047)	-2048	-2000	-1000	0	1000	2000	2047
Precise value (381 ~ 2023)	381	400	800	1200	1600	2000	2023
Percentile value (-12 ~ 1011)	-12	0	250	500	750	1000	1011

**Notes**

- 1) If analog input value exceeding digital output range is input, the digital output value will be kept to be the max. or the min. value applicable to the output range specified. For example, if the digital output range is set to unsigned value (0 ~ 4000) and the digital output value exceeding 4047 or analog value exceeding -0 is input, the digital output value will be fixed as 0~4047.
- 2) Voltage and current input shall not exceed  $\pm 15\text{ V}$  and  $\pm 25\text{ mA}$  respectively. Rising heat may cause defects.

## 2.6 Accuracy

Accuracy of digital output value does not change even if input range is changed. Figure below shows the range of the accuracy with analog input range of 0 ~ 10 V and digital output type of unsigned value selected.

Accuracy of XBF-AD04A is  $\pm 0.5\%$ .

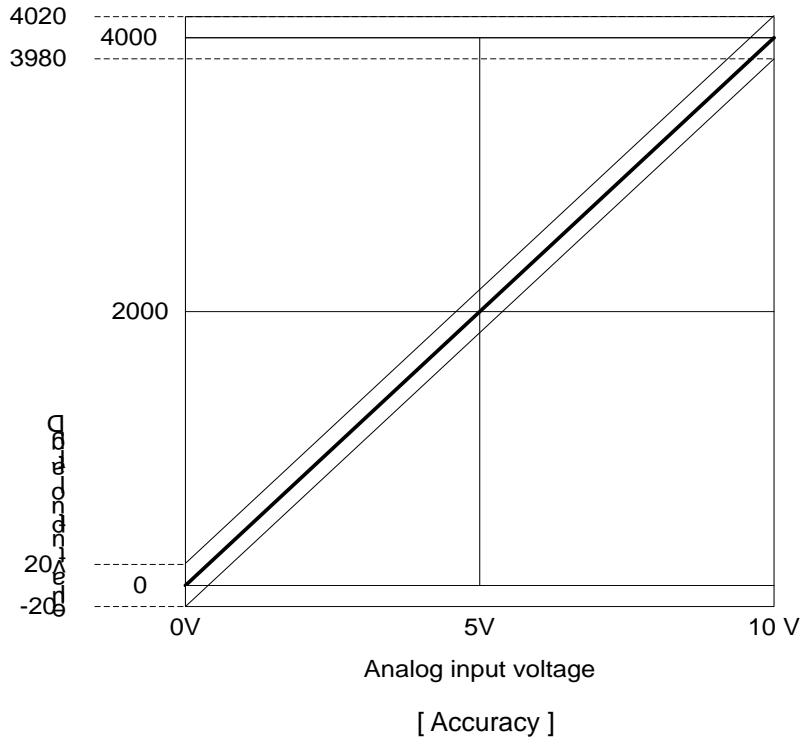

- (1) Accuracy when using 5V input  
 $4000 \times 0.5\% = 20$   
 Therefore the range of the accuracy will become  $(2000-20) \sim (2000+20) = 1980 \sim 2020$   
 when using 5V input.
- (2) Accuracy when using 10V input  
 $4000 \times 0.5\% = 20$   
 Therefore the range of the accuracy will become  $(4000-20) \sim (4000+20) = 3980 \sim 4020$   
 when using 10V input.

## 2.7 Functions of Analog Input Module

Functions of XBF-AD04A conversion module are as described below.

Function	Description
Channel Run/Stop setting	(1) Specify Run/Stop of the channel to execute A/D conversion. (2) If the unused channel is set to Stop, whole Run time can be reduced.
Input voltage/Current range setting	(1) Specify analog input range to be used. (2) Select range in parameter setting after select Voltage/Current switch.
Output data format setting	(1) Specify digital output type. (2) 4 output data formats are provided in this module.
A/D conversion methods	(1) Sampling processing Sampling process will be performed if A/D conversion type is not specified. (2) Filter processing Used to delay the sudden change of input value. (3) Average processing Outputs average A/D conversion value based on frequency or time.

There are three A/D conversion methods, sampling processing, filter processing and average processing.

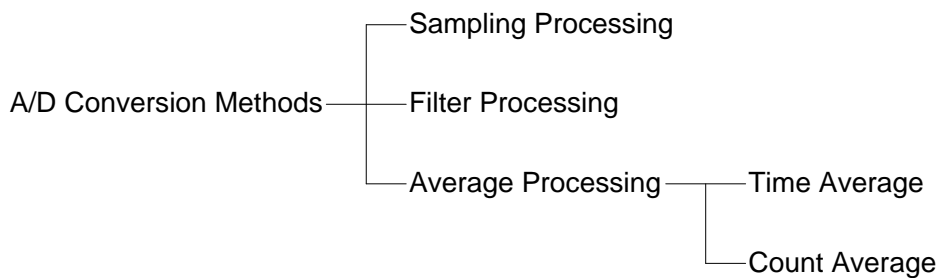

### (1) Sampling processing

It collects analog input sign through general A/D conversion processing at a specific interval so to convert to digital. The time required for A/D conversion of analog input sign till saved on the memory depends on the number of channels used.

$$(\text{Processing time}) = (\text{Number of channels used}) \times (\text{Conversion speed})$$

(Ex.) If the number of channels used is 3, its process time will be

$$3 \times 1.5 \text{ ms} = 4.5 \text{ ms}$$

Sampling is to calculate the sampling value of continuous analog sign at a specific interval.

(2) Filter processing

Filter process function is used to obtain stable digital output value by filtering (delaying) noise or sudden change of input value. Filter constant can be specified for respective channels through user program or I/O parameters setting.

- Setting range: 1 ~ 99 (%)

$$F[n] = (1 - \alpha) \times A[n] + \alpha \times F[n - 1]$$

added)

- F[n]: Present filter output value
- A[n]: Present A/D converted value
- F[n-1]: Previous filter output value
- A: Filter constant (0.01 ~ 0.99: previous value

□ If filter setting value is not specified within 1 ~ 99, RUN LED flickering at an interval of 1 second. In order to set RUN LED to On status, reset the filter setting value within 1 ~ 99 and then convert PLC CPU from STOP to RUN. Be sure to use request flag of error clear (UXY.11.0) to clear the error through modification during RUN.

- Analog input range: DC 0 ~ 10 V, Digital output range: 0 ~ 4000
- If analog input value changes 0 V → 10 V (0 → 4000), filter output value based on α value is as specified below.

αvalue	Filter output value				α value
	0 scan	1 scan	2 scan	3 scan	
*1) 0.01	0	3600	3960	3997	1% inclined toward previous value
*2) 0.66	0	1360	2257	2850	50% inclined toward previous value
*3) 0.99	0	40	80	119	99% inclined toward previous value

- 4000 output after about 4 scans
- 4000 output after about 18 scans
- 4000 output after about 950 scans(1.19 s for 1 channel Run)

□ If filter process function is not used, present A/D converted value will be output as it is. The filter process function takes value-added data between 'Present A/D converted value' and 'Previous A/D converted value'. And the value-added data can be decided with filter constant. If output data shakes too much, set a big filter constant value.

(3) Average processing

This process is used to execute A/D conversion of the channel designated for specified frequency or for specified time and save the average of the accumulated sum on memory. Average processing option and time/frequency value can be defined through user program or I/O parameters setting for respective channels.

(a) What is the average process used for

This process is used for A/D conversion of abnormal analog input signal such as noise to a value near to normal analog input signal.

(b) Average processing type

Average processing type is of time average and count average.

1) Time average processing

- Setting range: 4 ~ 16000 (ms)
- Average processing count within specified time is decided based on the number of channels used.

$$\text{Average processing count} = \frac{\text{Setting time}}{(\text{Number of Channels used}) \times (\text{Conversion Speed})}$$

Ex.1) Channels used: 1, setting time: 16000 ms

$$\text{Average processing count} = \frac{16000 \text{ ms}}{1 \times 1.5 \text{ ms}} = 10667 \text{ times}$$

Ex.2) Channels used: 4, setting time: 4 ms

$$\text{Average processing count} = \frac{4 \text{ ms}}{4 \times 1.5 \text{ ms}} = 1 \text{ times}$$

If setting value of time average is not specified within 4 ~ 16000, RUN LED flickering at an interval of 1 second. In order to set RUN LED to On status, reset the setting value of time average within 4 ~ 16000 and then convert PLC CPU from STOP to RUN. Be sure to use request flag of error clear (UXY.11.0) to clear the error through modification during RUN.

- Time average is processed after converted to average of the times inside the A/D conversion module. In this case, a remainder may be produced when setting time is divided by (number of channels used X conversion speed), which will be disregarded. Thus, the average processing frequency will be the quotient of [(setting time) ÷ (number of channels used x conversion speed)].

Ex.) If the number of channels used is 5, and setting time is 151 ms

$$151 \text{ ms} \div (4 \times 1.5 \text{ ms}) = 26 \text{ times} \dots\dots \text{Remainder of } 2 \rightarrow 26 \text{ times}$$

2) Count average process

- Setting range: 2 ~ 64000 (times)
- The time required for average value to be saved on memory when frequency average used depends on the number of channels used.

Process time = setting frequency X number of channels used X conversion speed

If setting value of count average is not specified within 2 ~ 64000, RUN LED flickering at an interval of 1 second. In order to set RUN LED to On status, reset the setting value of frequency average within 2 ~ 64000 and then convert PLC CPU from STOP to RUN. Be sure to use request flag of error clear (UXY.11.0) to clear the error through modification during RUN.

Ex.) If the number of channels used is 4, and average processing frequency is 50  
 $50 \times 4 \times (1.5 \text{ ms}) = 300 \text{ ms}$



## 2.8 Wiring

### 2.8.1 Precaution for wiring

- (1) Don't let AC power line near to A/D conversion module's external input sign line. With an enough distance kept away between, it will be free from surge or inductive noise.
- (2) Cable shall be selected in due consideration of ambient temperature and allowable current, whose size is not less than the max. cable standard of AWG22 (0.3mm<sup>2</sup>).
- (3) Don't let the cable too close to hot device and material or in direct contact with oil for long, which will cause damage or abnormal operation due to short-circuit.
- (4) Check the polarity when wiring the terminal.
- (5) Wiring with high-voltage line or power line may produce inductive hindrance causing abnormal operation or defect.

### 2.8.2 Wiring examples

- (1) Example of voltage wiring

- In case of voltage/current input, wiring is same. Adjust the voltage/current setting switch according to the case.

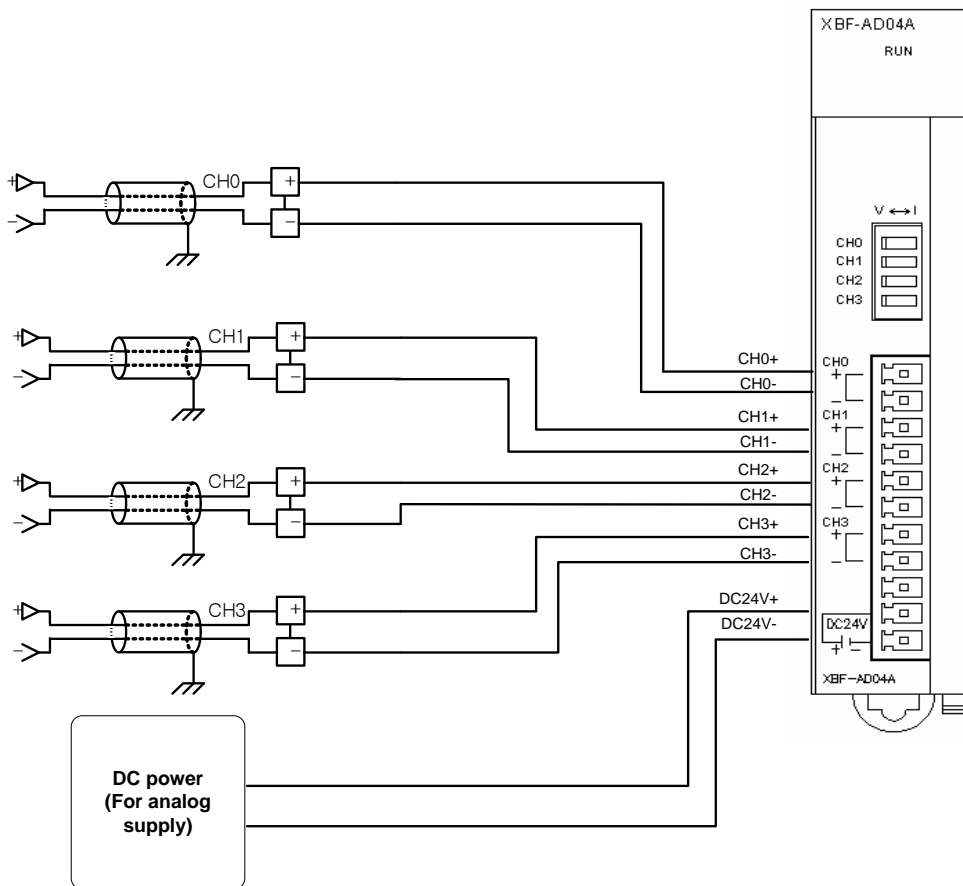

- (a) Input resistance of current input circuit is 250  $\Omega$  (typ.).
- (b) Input resistance of voltage input circuit is 1 M $\Omega$  (min.).
- (c) Enable the necessary channel only.
- (d) Analog input module doesn't support power for input device. Use the external power supplier.

(2) Wiring example of 2-Wire sensor/transmitter (current input)

- In case of voltage/current input, wiring is same. Adjust the voltage/current setting switch according to the case.

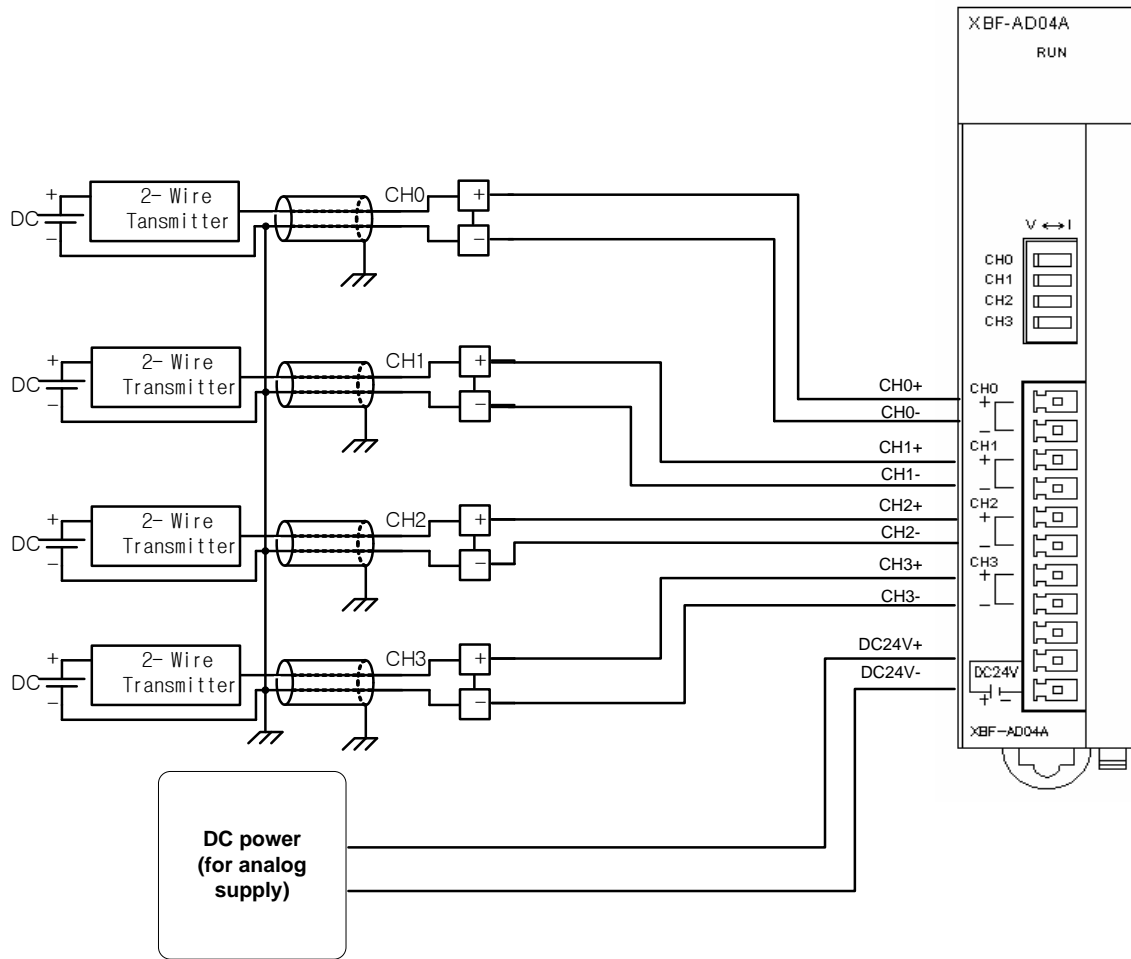

- (a) Input resistance of current input circuit is  $250\ \Omega$  (typ.).
- (b) Input resistance of voltage input circuit is  $1\ \text{M}\Omega$  (min.).
- (c) Enable the necessary channel only.
- (d) Analog input module doesn't support power for input device. Use the external power supplier.

(3) Wiring example of 4-Wire sensor/transmitter (Voltage/Current input)  
 - In case of voltage/current input, wiring is same. Adjust the voltage/current setting switch according to the case.

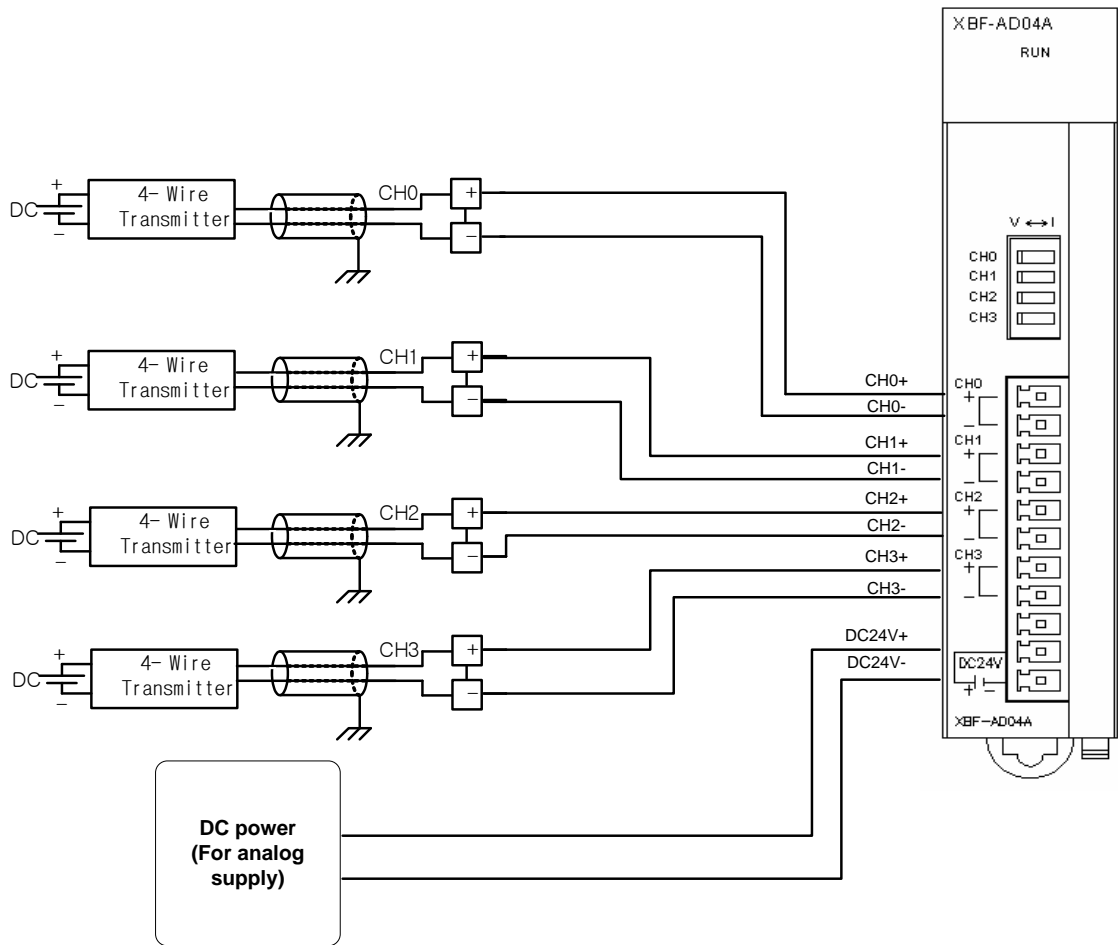

- (a) Input resistance of current input circuit is 250 Ω (typ.).
- (b) Input resistance of voltage input circuit is 1 MΩ (min.).
- (c) Enable the necessary channel only.
- (d) Analog input module doesn't support power for input device. Use the external power supplier.

(4) Relationship between voltage input accuracy and wiring length

In voltage input, the wiring (cable) length between transmitter or sensor and module has an effect on digital-converted values of the module as specified below.

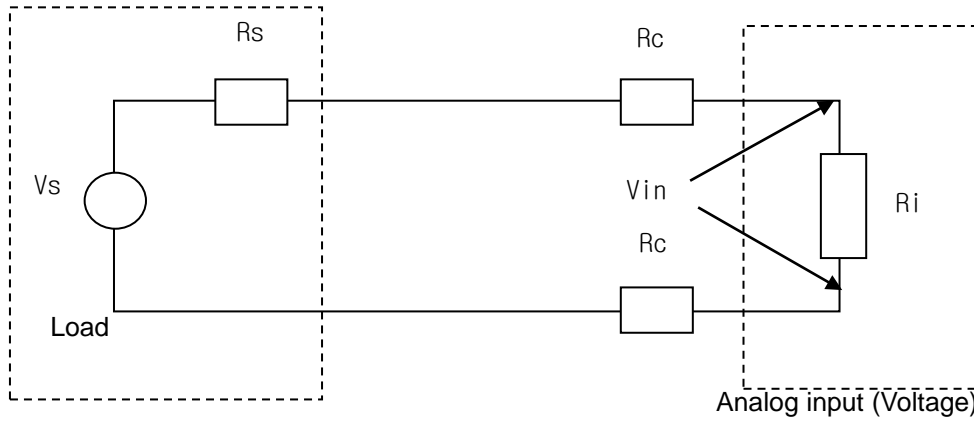

Where,

$R_c$ : Resistance value due to line resistance of cable

$R_s$ : Internal resistance value of transmitter or sensor

$R_i$ : Internal resistance value ( $1M\Omega$ ) of voltage input module

$V_{in}$ : Voltage allowed to analog input module

%  $V_i$ : Tolerance of converted value (%) due to source and cable length in voltage input

$$V_{in} = \frac{R_i \times V_s}{[R_s + (2 \times R_c) + R_i]}$$

$$\% V_i = \left(1 - \frac{V_{in}}{V_s}\right) \times 100 \%$$

## 2.9 Operation Parameter Setting

A/D conversion module's operation parameters can be specified through XG5000's [I/O parameters].

(1) Settings

For the user's convenience of A/D conversion module, XG5000 provides GUI (Graphical User Interface) for parameters setting of A/D conversion module. Setting items available through [I/O parameters] on the XG5000 project window are as described below in the table.

Item	Details
[I/O parameter]	<p>(1) Specify the following setting items necessary for the module operation.</p> <ul style="list-style-type: none"> <li>- Channel Enable/Disable setting</li> <li>- Setting ranges of input voltage/current</li> <li>- Output data format setting</li> <li>- Filter processing Enable/Disable setting</li> <li>- Filter constant setting</li> <li>- Average processing Enable/Disable setting</li> <li>- Average processing method setting</li> <li>- Average value setting</li> </ul> <p>(2) The data specified by user through S/W package will be saved on A/D conversion module when [Special Module Parameters] are downloaded. In other words, the point of time when [Special Module Parameters] are saved on A/D conversion module has nothing to do with PLC CPU's status RUN or STOP.</p>

(2) I/O Parameter setting

- (a) Run XG5000 to create a project.  
(Refer to XG5000 program manual for details on how to create the project)
- (b) Double-click [I/O parameters] on the project window.

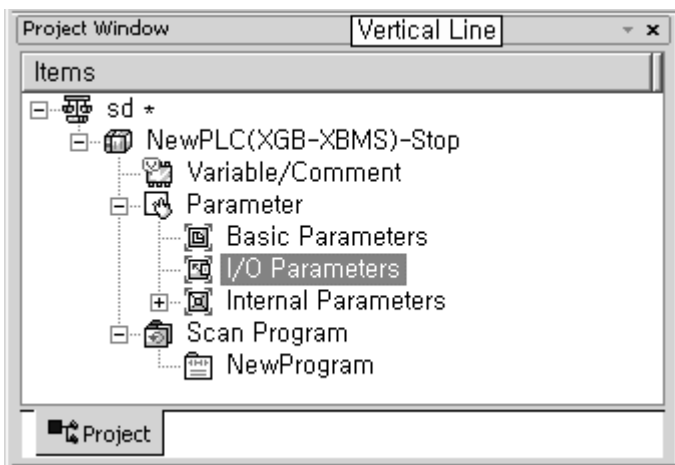

- (c) On the 'I/O parameters setting' screen, find and click the slot of the base A/D conversion module is installed on. 4-channel voltage type of A/D conversion module is installed on Base No.0, Slot No.4 in this description.

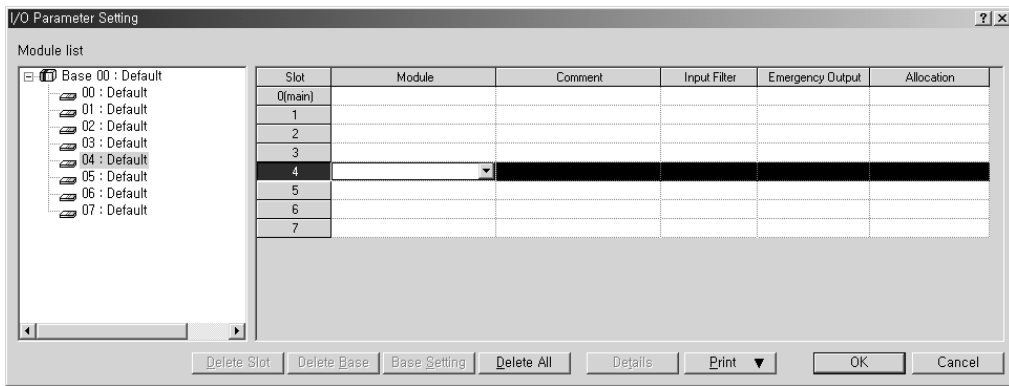

(d) Click the arrow button on the screen above to display the screen where an applicable module can be selected. Search for the applicable module to select.

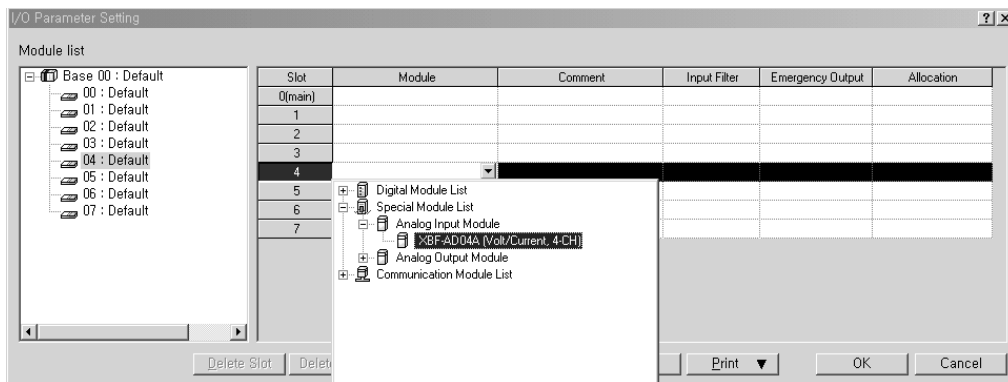

(e) After the module selected, click [Details].

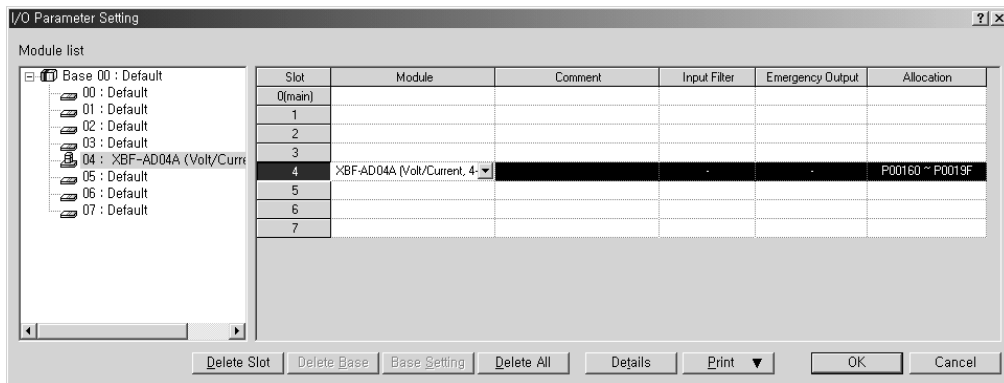

(f) A screen will be displayed for you to specify parameters for respective channels as shown below. Click a desired item to display parameters to set for respective items.

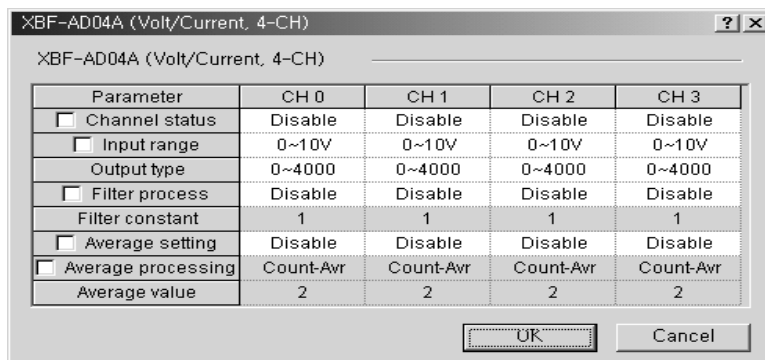

## 2.10 Special Module Monitoring Functions

Functions of Special Module Monitoring are as described below.

(1) Monitor/Test

Through applicable XG5000 menu of [Monitor] -> [Special Module Monitoring], A/D converted value can be monitored and the operation of A/D conversion module can be tested.

(2) Monitoring the max./min. value

The max./min. value of the channel can be monitored during Run. However, the max./min. value displayed here is based on the present value shown on the screen. Accordingly, when [Monitoring/Test] screen is closed, the max./min. value will not be saved.

- The parameters specified for the test of A/D conversion module on the “Special Module Monitoring” screen of [Special Module Monitoring] will be deleted the moment the “Special Module Monitoring” screen is closed. In other words, the parameters of A/D conversion module specified on the “Special Module Monitoring” screen will not be saved in [I/O parameters] located

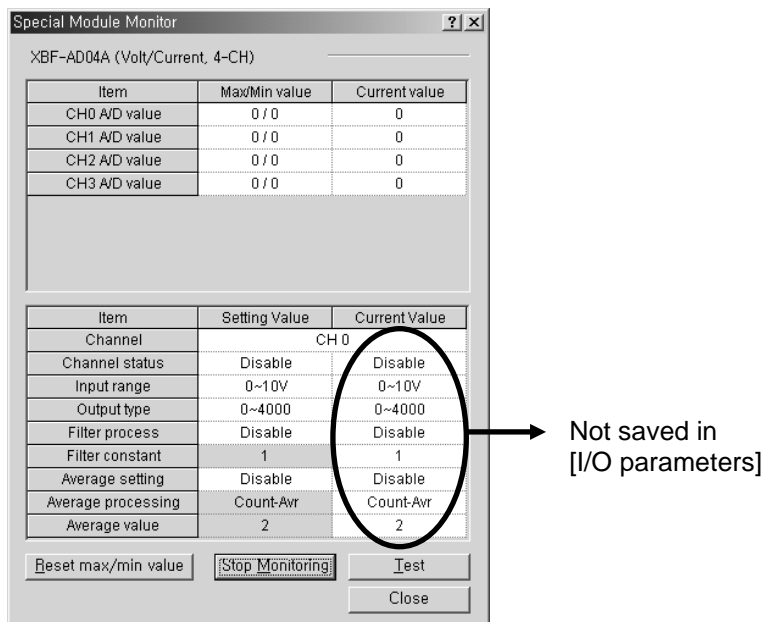

- Test function of [Special Module Monitoring] is provided for user to check the normal operation of A/D conversion module even without sequence programming. If A/D conversion module is to be used for other purposes than a test, use parameters setting function in [I/O parameters].

### 2.10.1 How to use special module monitoring

Monitoring special module will be based on XBF-AD04A.

(1) Start of [Special Module Monitoring]

Go through [OnLine] -> [Connect] and [Monitor] -> [Special Module Monitoring] to start. If the status is not [OnLine], [Special Module Monitoring] menu will not be active.

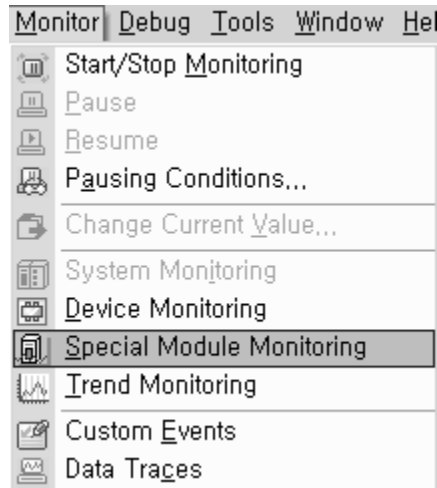

(2) How to use [Special Module Monitoring]

(a) With XG5000 connected to PLC CPU (on-line status), click [Monitor] -> [Special Module Monitoring] to display 'Special Module Select' screen as in Fig. 5.1 showing base/slot information in addition to special module type. The module installed on the present PLC system will be displayed on the list dialog box.

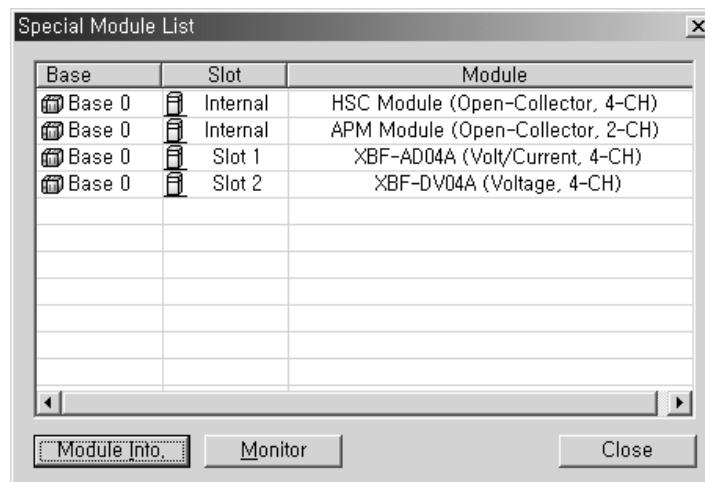



(b) Select Special module and click [Module information] to display the information as below.

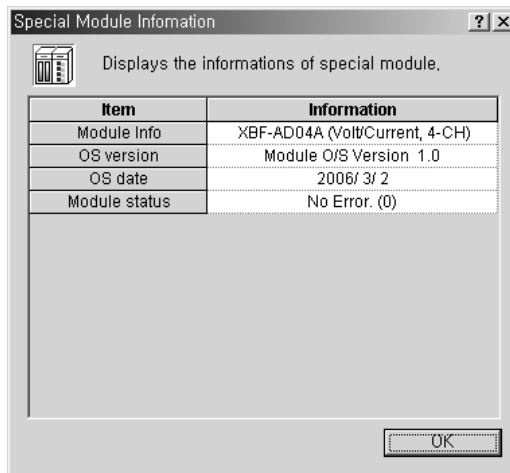

(c) Click [Monitor] on the “Special Module” screen in [Special Module List] to display [Special Module Monitoring] screen as below, where 4 options are available such as [Reset max./min. value], [start Monitoring], [Test] and [Close]. A/D conversion module’s output value and max./ min. value are displayed on the monitoring screen at the top of the screen, and parameters items of respective modules are displayed for individual setting on the test screen at the bottom of the screen.

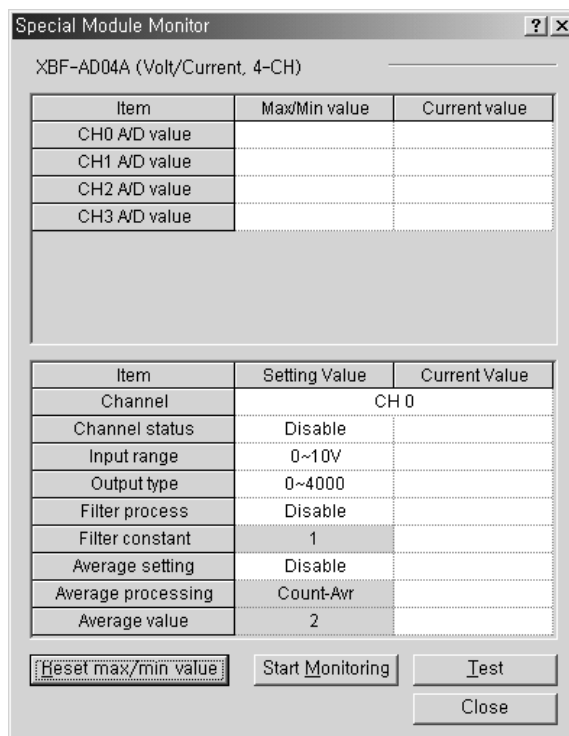

(d) [Start Monitoring]: Click [Start Monitoring] to display A/D converted value of the presently operated channel. Below screen is the monitoring screen displayed when the whole channels are in Stop status. In the present value field at the screen bottom, presently specified parameters of A/D conversion module are displayed

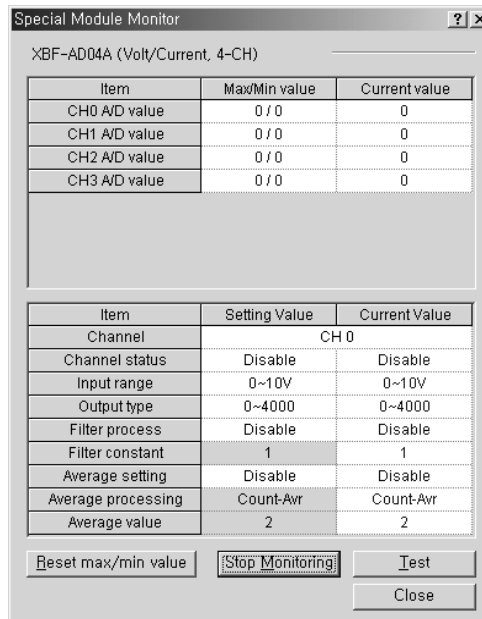

Execution screen of [Start Monitoring]

(e) [Test]: [Test] is used to change the presently specified parameters of A/D conversion module. Click the setting value at the bottom field of the screen to change parameters. Below screen will be displayed after [Test] is executed with channels 0's input voltage range changed to 0~20 mA in the state of input not wired.

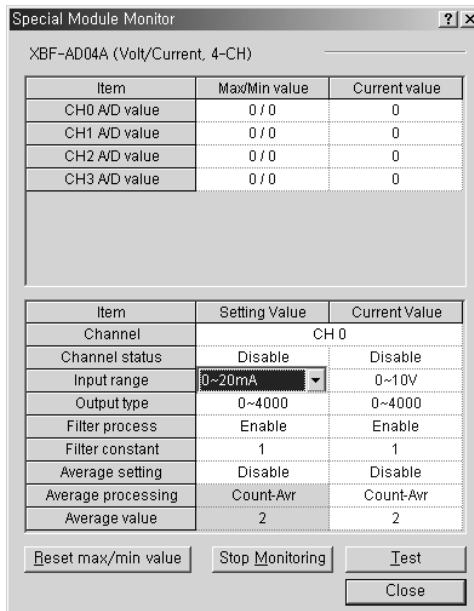

Execution screen of [Test]

- (f) [Reset max/min value]: The max/min value field at the upper screen shows the max. value and the min. value of A/D converted value. Click [Reset max/min value] to initialize the max./min. value. Below screen is after [Reset max/min value] button is clicked in the screen of Special Module Monitor, where channel 0's A/D converted value can be checked as reset.

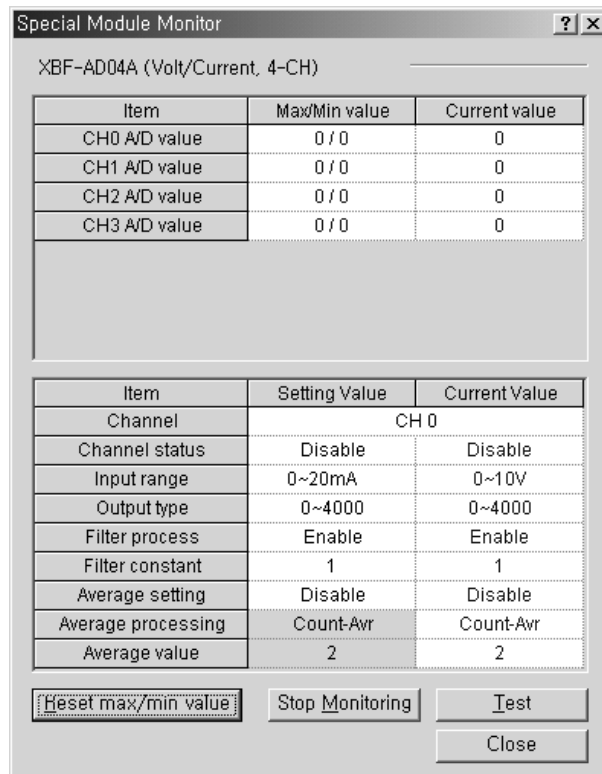

Execution screen of [Reset max/min value]

- (g) [Close]: [Close] is used to escape from the monitoring/test screen. When the monitoring/test screen is closed, the max. value, the min. value and the present value will not be saved any more.

## 2.11 Register U devices

Register the variables for each module referring to the special module information that is set in the I/O parameter. The user can modify the variables and comments.

(1) Procedure

(a) Select the special module type in the [I/O Parameter Setting] window.

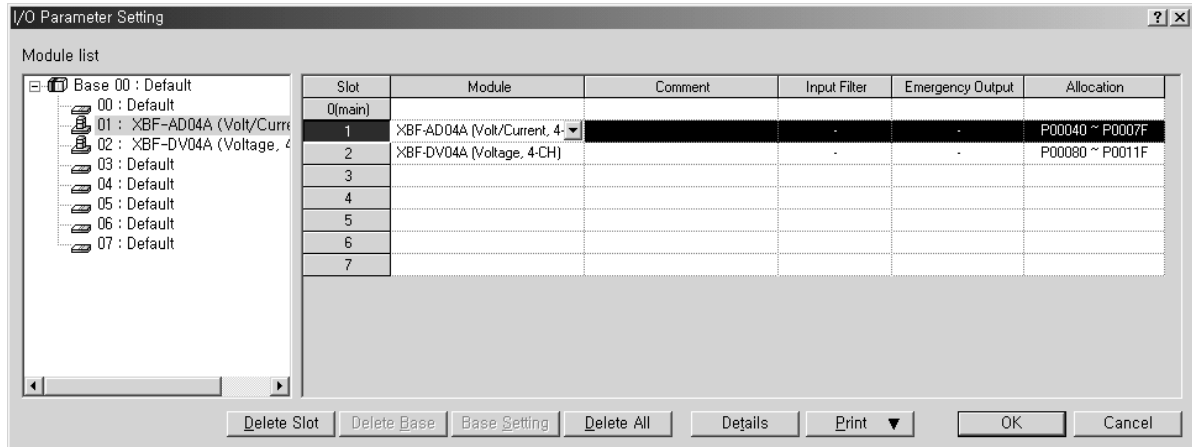

(b) Double click 'Variable/Comment' from the project window.

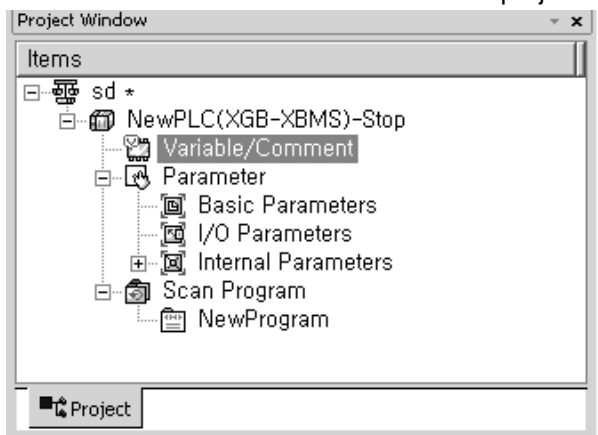

(c) Select [Edit] – [Register U Device].

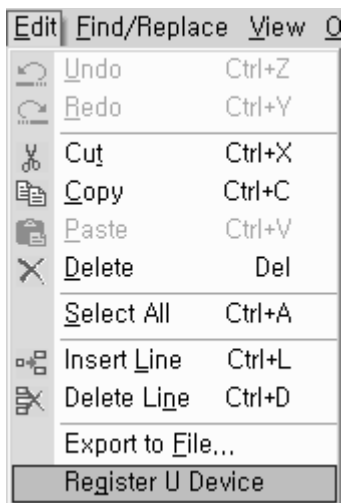

(d) Click 'Yes'.

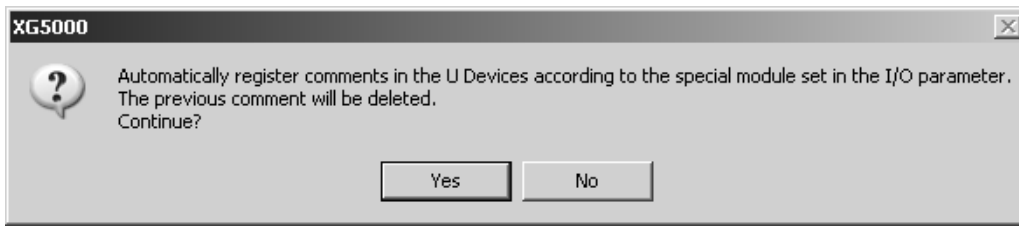

(e) As shown below, the variables are registered.

Variable	Type	Device	Comment
1 Start_Condition	BIT	M0000	
2 _01_ERR	BIT	U01.00.0	Analog Input Module: Module Error
3 _01_RDV	BIT	U01.00.F	Analog Input Module: Module Ready
4 _01_CH0_ACT	BIT	U01.01.0	Analog Input Module: CH0 Active
5 _01_CH1_ACT	BIT	U01.01.1	Analog Input Module: CH1 Active
6 _01_CH2_ACT	BIT	U01.01.2	Analog Input Module: CH2 Active
7 _01_CH3_ACT	BIT	U01.01.3	Analog Input Module: CH3 Active
8 _01_CH0_IDD	BIT	U01.10.0	Analog Input Module: CH0 Input Disconnection Flag
9 _01_CH1_IDD	BIT	U01.10.1	Analog Input Module: CH1 Input Disconnection Flag
10 _01_CH2_IDD	BIT	U01.10.2	Analog Input Module: CH2 Input Disconnection Flag
11 _01_CH3_IDD	BIT	U01.10.3	Analog Input Module: CH3 Input Disconnection Flag
12 _01_ERR_CLR	BIT	U01.11.2	Analog Input Module: Error Clear Request
13 _02_CH0_ERR	BIT	U02.00.0	Analog Output Module: CH0 Error
14 _02_CH1_ERR	BIT	U02.00.1	Analog Output Module: CH1 Error
15 _02_CH2_ERR	BIT	U02.00.2	Analog Output Module: CH2 Error
16 _02_CH3_ERR	BIT	U02.00.3	Analog Output Module: CH3 Error
17 _02_RDV	BIT	U02.00.F	Analog Output Module: Module Ready
18 _02_CH0_ACT	BIT	U02.01.0	Analog Output Module: CH0 Active
19 _02_CH1_ACT	BIT	U02.01.1	Analog Output Module: CH1 Active
20 _02_CH2_ACT	BIT	U02.01.2	Analog Output Module: CH2 Active
21 _02_CH3_ACT	BIT	U02.01.3	Analog Output Module: CH3 Active
22 _02_CH0_OUTEN	BIT	U02.02.0	Analog Output Module: CH0 Output Status Setting
23 _02_CH1_OUTEN	BIT	U02.02.1	Analog Output Module: CH1 Output Status Setting
24 _02_CH2_OUTEN	BIT	U02.02.2	Analog Output Module: CH2 Output Status Setting

(f) For IEC type, as shown below, the variables are registered.

Variable Kind	Variable	Type	Address	Initial Value	Retain	Used	Comment
1 VAR_GLOBAL	_01_ADDO_ACT	BOOL	\$XUD.1.16		<input type="checkbox"/>	<input type="checkbox"/>	Analog IO Module: Input CH0 Active
2 VAR_GLOBAL	_01_ADDO_DATA	WORD	\$XUD.1.4		<input type="checkbox"/>	<input type="checkbox"/>	Analog IO Module: Input CH0 Data
3 VAR_GLOBAL	_01_ADDO_ERR	BOOL	\$XUD.1.24		<input type="checkbox"/>	<input type="checkbox"/>	Analog IO Module: Input CH0 Error
4 VAR_GLOBAL	_01_ADDO_IDD	BOOL	\$XUD.1.20		<input type="checkbox"/>	<input type="checkbox"/>	Analog IO Module: Input CH0 Disconnection
5 VAR_GLOBAL	_01_ADD1_ACT	BOOL	\$XUD.1.17		<input type="checkbox"/>	<input type="checkbox"/>	Analog IO Module: Input CH1 Active
6 VAR_GLOBAL	_01_ADD1_DATA	WORD	\$XUD.1.5		<input type="checkbox"/>	<input type="checkbox"/>	Analog IO Module: Input CH1 Data
7 VAR_GLOBAL	_01_ADD1_ERR	BOOL	\$XUD.1.25		<input type="checkbox"/>	<input type="checkbox"/>	Analog IO Module: Input CH1 Error
8 VAR_GLOBAL	_01_ADD1_IDD	BOOL	\$XUD.1.21		<input type="checkbox"/>	<input type="checkbox"/>	Analog IO Module: Input CH1 Disconnection
9 VAR_GLOBAL	_01_ADDO_ACT	BOOL	\$XUD.1.18		<input type="checkbox"/>	<input type="checkbox"/>	Analog IO Module: Output CH0 Active
10 VAR_GLOBAL	_01_ADDO_DATA	WORD	\$XUD.1.7		<input type="checkbox"/>	<input type="checkbox"/>	Analog IO Module: Output CH0 DATA
11 VAR_GLOBAL	_01_ADDO_ERR	BOOL	\$XUD.1.26		<input type="checkbox"/>	<input type="checkbox"/>	Analog IO Module: Output CH0 Error
12 VAR_GLOBAL	_01_ADDO_OUTEN	BOOL	\$XUD.1.96		<input type="checkbox"/>	<input type="checkbox"/>	Analog IO Module: Output CH0 Status Setti
13 VAR_GLOBAL	_01_ADD1_ACT	BOOL	\$XUD.1.19		<input type="checkbox"/>	<input type="checkbox"/>	Analog IO Module: Output CH1 Active
14 VAR_GLOBAL	_01_ADD1_DATA	WORD	\$XUD.1.8		<input type="checkbox"/>	<input type="checkbox"/>	Analog IO Module: Output CH1 DATA
15 VAR_GLOBAL	_01_ADD1_ERR	BOOL	\$XUD.1.27		<input type="checkbox"/>	<input type="checkbox"/>	Analog IO Module: Output CH1 Error
16 VAR_GLOBAL	_01_ADD1_OUTEN	BOOL	\$XUD.1.97		<input type="checkbox"/>	<input type="checkbox"/>	Analog IO Module: Output CH1 Status Setti
17 VAR_GLOBAL	_01_ERR	BOOL	\$XUD.1.0		<input type="checkbox"/>	<input type="checkbox"/>	Analog IO Module: Module Error
18 VAR_GLOBAL	_01_RDV	BOOL	\$XUD.1.15		<input type="checkbox"/>	<input type="checkbox"/>	Analog IO Module: Module Ready

(2) Save variables

- (a) The contents of 'View Variable' can be saved as a text file.
- (b) Select [Edit] -> [Export to File].
- (c) The contents of 'View variable' are saved as a text file.

(3) View variables

The example of XGB 'S' type and 'H' type is as follows.

(a) The example program of XG5000 is as shown below.

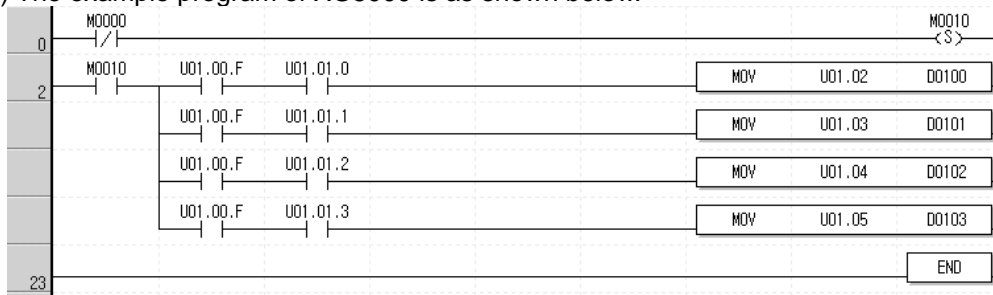

(b) Select [View] -> [Variables]. The devices are changed into variables.

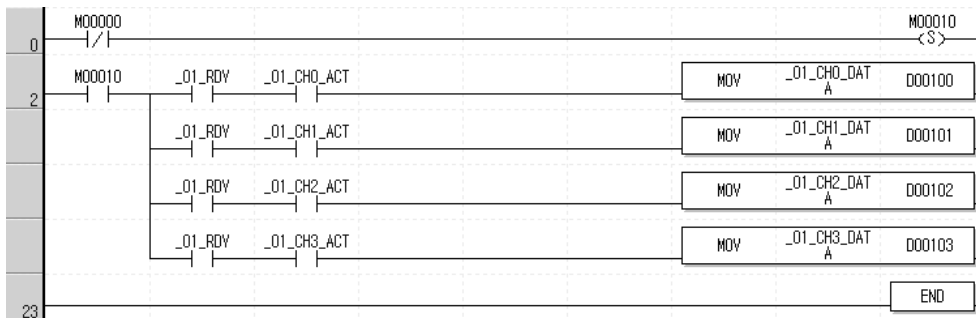

(c) Select [View] -> [Devices/Variables]. Devices and variables are both displayed.

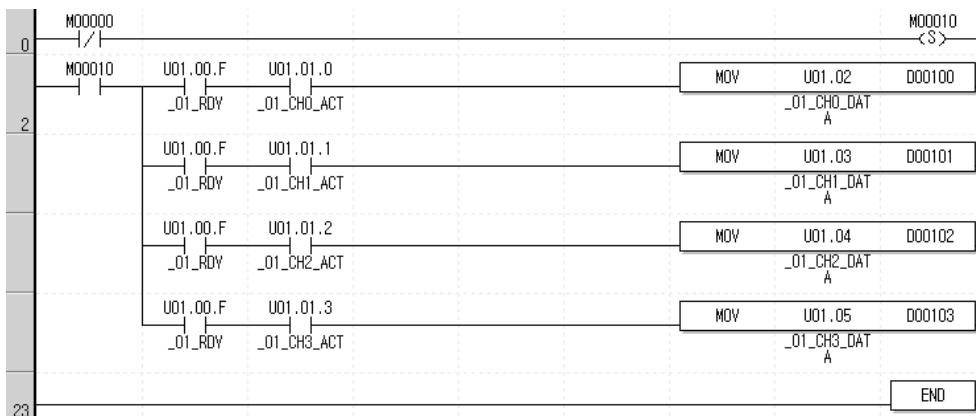

## Chapter 2 Analog Input (XBF-AD04A)

(d) Select [View] -> [Device/Comments]. Devices and comments are both displayed.

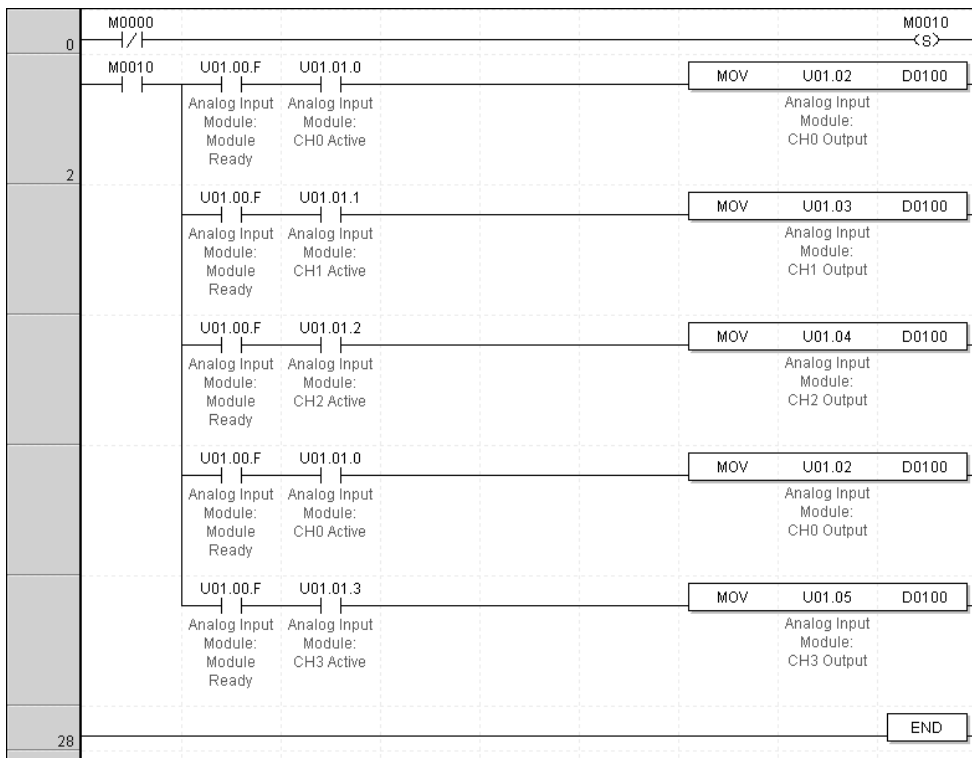

(e) In case of IEC, you can see variables with diverse option at 'View' menu like (b)-(d). The following is example selecting 'View Variable/Comment' at IEC type.

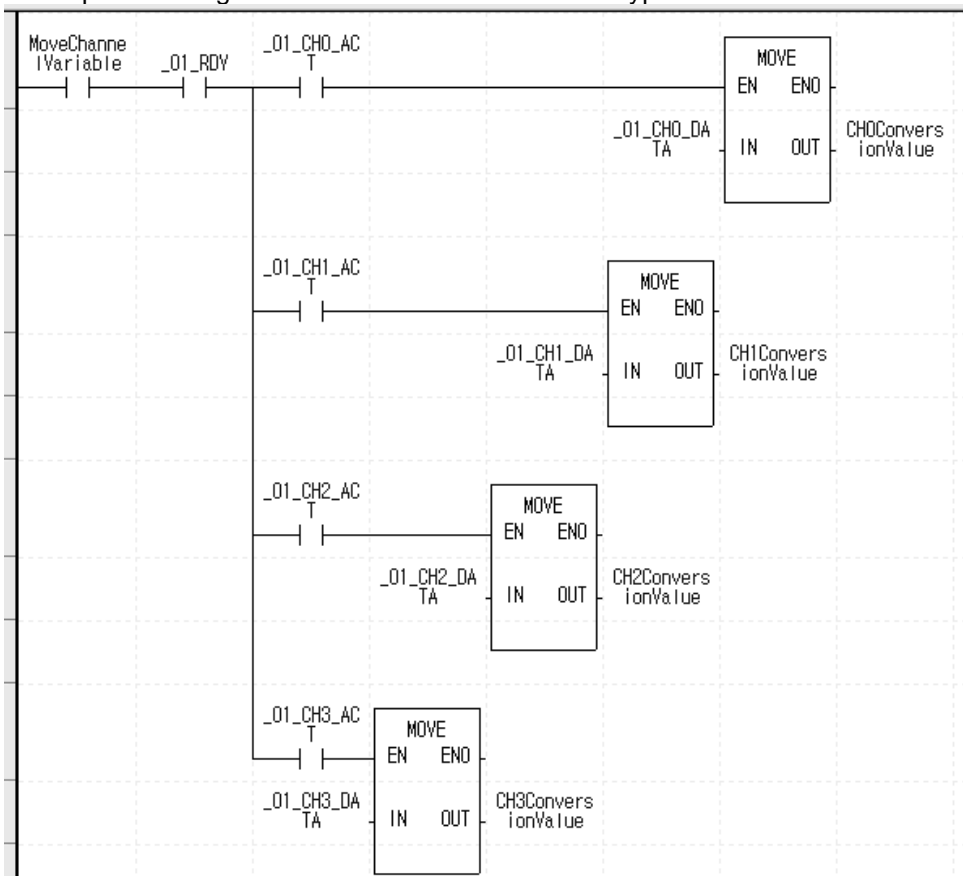

## 2.12 Configuration and Function of Internal Memory

A/D conversion module has the internal memory to transmit/receive data to/from PLC CPU.

### 2.12.1 I/O area of A/D converted data

I/O area of A/D converted data is as displayed in table.

Device assigned ("S" or "H" type)	Device assigned (IEC type)	Details	R/W	Sign direction
UXY.00.0 UXY.00.F	%UX0.x.0 %UX0.x.15	Module ERROR flag Module READY flag	R	A/D → CPU
UXY.01.0 UXY.01.1 UXY.01.2 UXY.01.3	%UX0.x.16 %UX0.x.17 %UX0.x.18 %UX0.x.19	CH0 Run flag CH1 Run flag CH2 Run flag CH3 Run flag	R	A/D → CPU
UXY.02	%UW0.x.2	Ch0 digital output value	R	A/D → CPU
UXY.03	%UW0.x.3	Ch1 digital output value	R	
UXY.04	%UW0.x.4	Ch2 digital output value	R	
UXY.05	%UW0.x.5	Ch3 digital output value	R	
UXY.11.0	%UX0.x.176	Flag to request error clear	W	CPU → A/D

- In the device assigned, X stands for the Base No. and Y for the Slot No. on which module is installed.
- In order to read 'CH1 digital output value' of A/D conversion module installed on Base No.0, Slot No.4, it shall be displayed as U04.03. (in case of IEC type, %UW0.4.3)

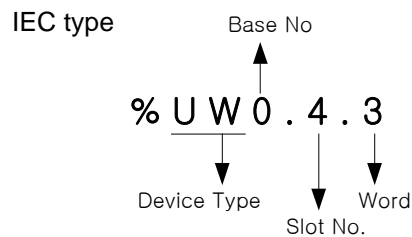
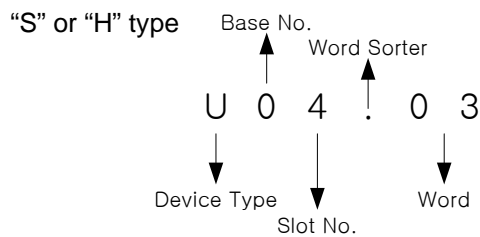

- In order to read 'Flag to detect CH4 disconnection' of A/D conversion module installed on Base No.0, Slot No.5, it shall be displayed as U05.10.4.

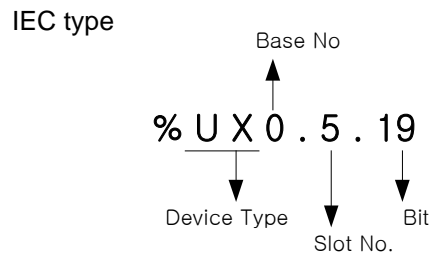
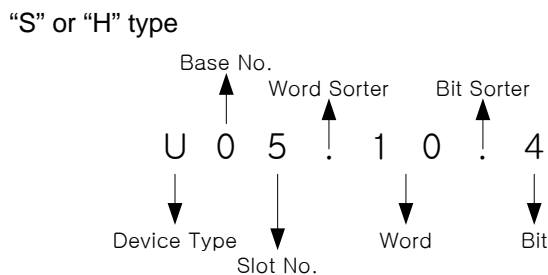



- (1) Module Ready/Error flag (U0x.00, x: slot number)
  - (a) U0x.00.F: It will be ON when PLC CPU is powered or reset with A/D conversion ready to process A/D conversion.
  - (b) U0x.00.0: It is a flag to display the error status of A/D conversion module.

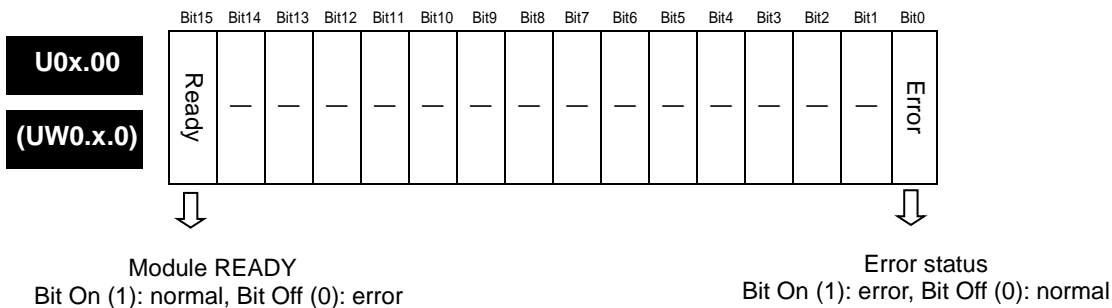

- (2) Run channel flag (UXY.01, X: Base No., Y: Slot No.)  
 The area where Run information of respective channels is saved  
 \* XGB series base number is 0

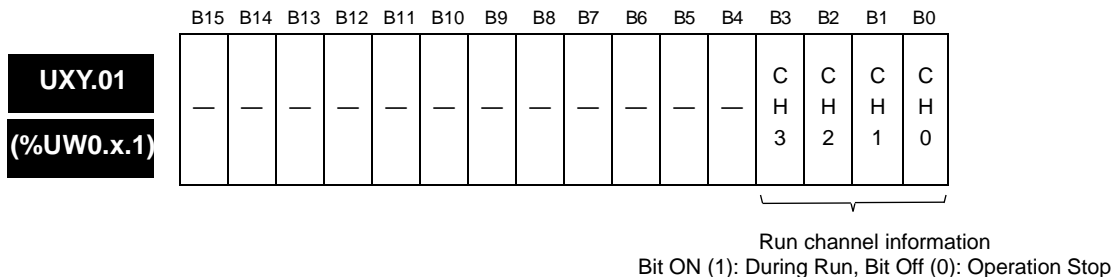

- (3) Digital output value (UXY.02 ~ UXY.09, X: Base No., Y: Slot No.)
  - (a) A/D converted-digital output value will be output to buffer memory addresses UXY.02 ~ UXY.05 (%UW0.x.2 ~ %UW0.x.5) for respective channels.
  - (b) Digital output value will be saved in 16-bit binary.
  - ※ XGB PLC's base number is 0.

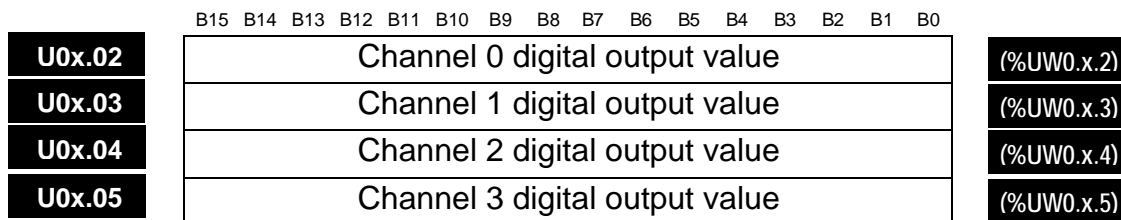

- (4) Flag to request error clear (( ) means the case of IEC type, x: slot number)
- (a) If a parameters setting error occurs, address No.22's error code will not be automatically erased even if parameters are changed correctly. At this time, turn the 'error clear request' bit ON to delete address No.22's error code and the error displayed in XG5000's [System Monitor]. In addition, RUN LED which flickering will be back to On status.
  - (b) The 'flag to request error clear' shall be used surely together with UXY.00.0 attached thereon for guaranteed Normal operation.
    - ※ XGB PLC base number is 0

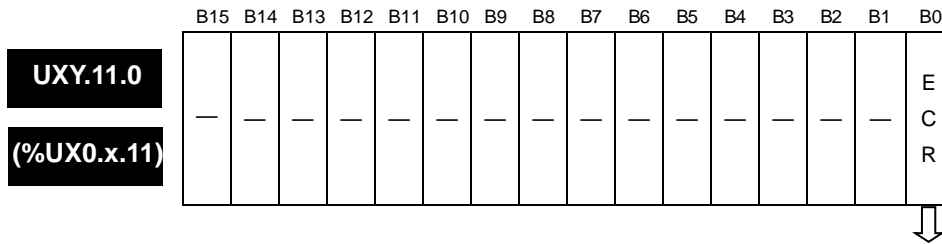

Flag to request error clear (UXY.11.0)  
 Bit ON (1): Error clear request, Bit Off (0): Error clear standing-by



[How to use the flag to request error clear ("S" type or "H" type)]

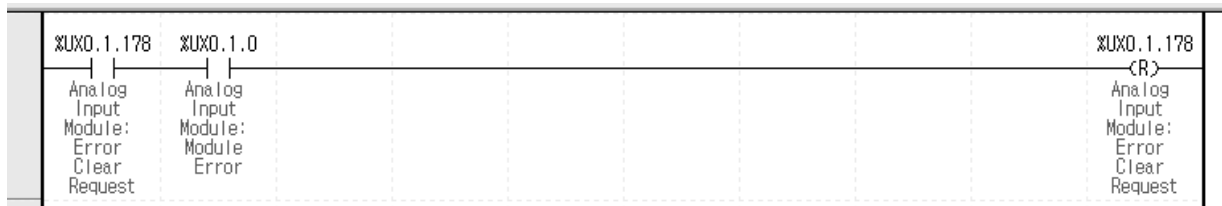

[How to use the flag to request error clear (IEC type)]

2.12.2 Operation parameters setting area

Setting area of A/D conversion module's Run parameters is as described in Table.

Memory address		Details	R/W	Remark
Hex.	Dec.			
0 <sub>H</sub>	0	Channel enable/disable setting	R/W	PUT
1 <sub>H</sub>	1	Setting ranges of input voltage/current	R/W	PUT
2 <sub>H</sub>	2	Output data format setting	R/W	PUT
3 <sub>H</sub>	3	Filter processing enable/disable setting	R/W	PUT
4 <sub>H</sub>	4	CH0 filter constant	R/W	PUT
5 <sub>H</sub>	5	CH1 filter constant		
6 <sub>H</sub>	6	CH2 filter constant		
7 <sub>H</sub>	7	CH3 filter constant		
C <sub>H</sub>	12	Average processing enable/disable setting	R/W	PUT
D <sub>H</sub>	13	Average processing method setting	R/W	
E <sub>H</sub>	14	CH0 average value	R/W	
F <sub>H</sub>	15	CH1 average value		
10 <sub>H</sub>	16	CH2 average value		
11 <sub>H</sub>	17	CH3 average value		
16 <sub>H</sub>	22	Error code	R/W	GET

※ R/W is to denote Read/Write if available from PLC program.

(1) Setting operation channels

If the channel to use is not specified, all the channels will be set to prohibit.

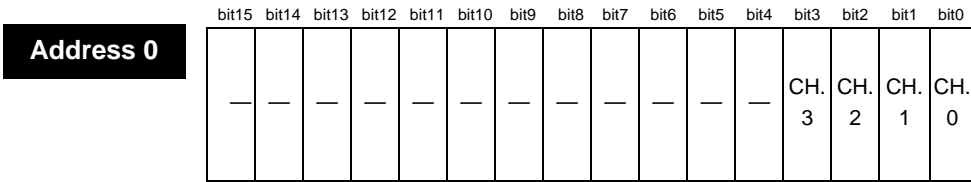

Setting channel to use (bit)  
Bit On (1): Run, Bit Off (0): Stop

(2) Setting input range

The range of analog voltage input is DC 0~10V, the range of analog current input is DC 4~20mA.

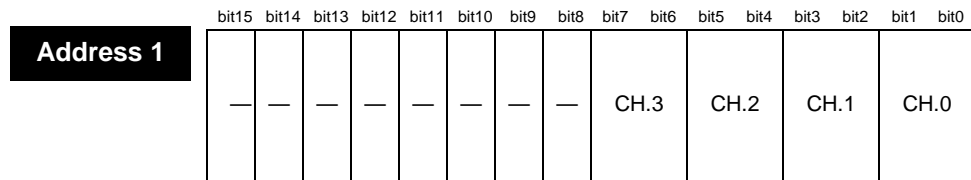

Setting input range (bit)  
 → 00: 0 ~ 10V  
 → 01: 0 ~ 20mA  
 → 10: 4 ~ 20mA

(3) Setting output data type

- (a) The range of digital output data for analog input can be specified for respective channels.
- (b) If the output data range is not specified, the range of all the channels will be set to 0 ~ 4000.

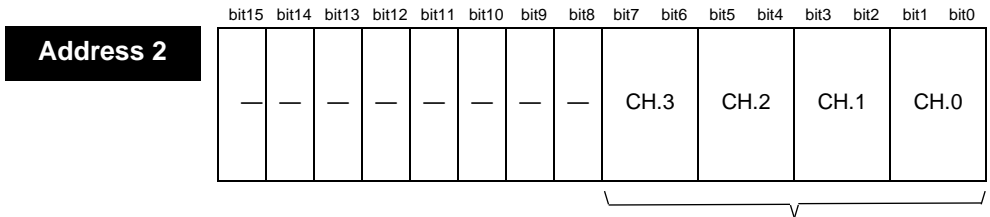

Setting output data type (bit)  
 → 00: 0 ~ 4000  
 → 01: -2000 ~ 2000  
 → 10: 0 ~ 1000(400 ~ 2000/0 ~ 2000)  
 → 11: 0 ~ 1000

(4) Setting filter process

If the filter process is not specified, the filter process of all channels will not be executed.

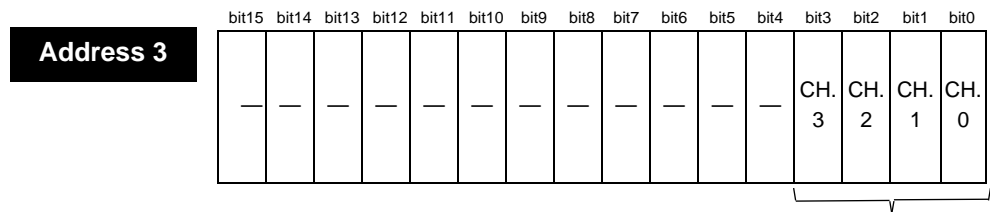

Setting filter process (bit)  
 Bit On (1): used, bit Off (0): not used

(5) Setting filter constant

When using the filter process, specify the filter constant.

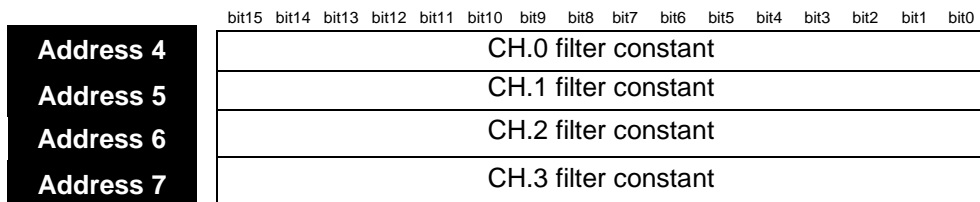

(6) Setting average process

If the average process is not specified, the average process of all channels will not be executed.

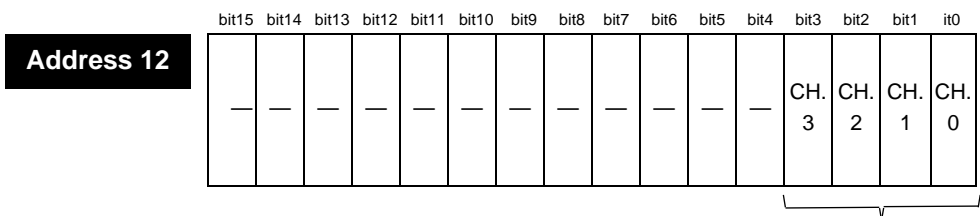

Setting average process (bit)  
 Bit On (1): used, Bit Off (0): not used

(7) Setting average process method

This area is used to specify average processing method, where 'count average' and 'time average' are available.

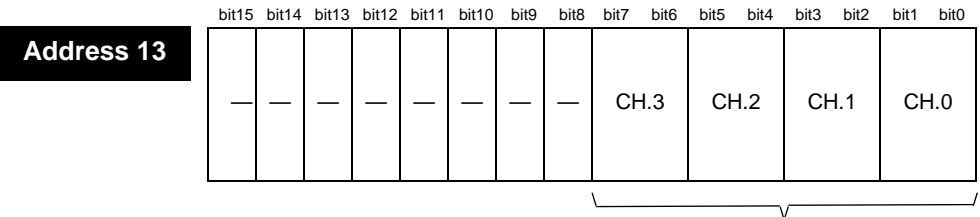

Setting average process method (bit)  
 → 00: count average  
 → 01: time average

(8) Error code (address 22)

- (a) It saves the error code detected from A/D conversion module.
- (b) Error type and details is as below.

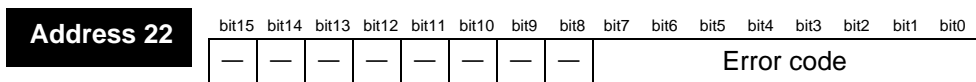

Error code (Dec.)	Details	Remark
0	Normal operation	RUN LED flickering
50#	Exceeding of filter constant setting range	Flickering RUN LED 1s intervals
60#	Exceeding of time average setting range	
70#	Exceeding of Frequency average setting range	
80#	Setting error of analog input range	

※ # of the error codes stands for the channel with error found.

- (c) If 2 or more errors occur, the module sill not save other error codes than the first error code found.
- (d) If an error found is corrected, use the 'flag to request error clear', or let power OFF → ON in order to stop LED blinking and to delete the error code.

## 2.13 Example Program

### 2.13.1 Program to sort A/D converted value in size

#### (1) System configuration

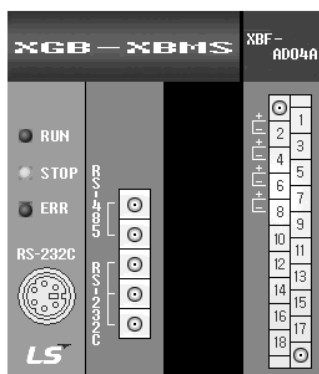

System information	Assigns Information - Fixed Location	Comment
<ul style="list-style-type: none"> <li>Base 0 : XGB-M08A <ul style="list-style-type: none"> <li>CPU: XGB-XBMS</li> <li>Slot 0: Internal Cnet</li> <li>Slot 0: XBM_DN32S</li> <li>Slot 1: XBF_AD04A</li> <li>Slot 2: Empty slot</li> <li>Slot 3: Empty slot</li> <li>Slot 4: Empty slot</li> <li>Slot 5: Empty slot</li> <li>Slot 6: Empty slot</li> <li>Slot 7: Empty slot</li> </ul> </li> </ul>	<ul style="list-style-type: none"> <li>[P0000 ~ P003F]</li> <li>[P0040 ~ P007F]</li> <li>[P0080 ~ P011F]</li> <li>[P0120 ~ P015F]</li> <li>[P0160 ~ P019F]</li> <li>[P0200 ~ P023F]</li> <li>[P0240 ~ P027F]</li> <li>[P0280 ~ P031F]</li> </ul>	<ul style="list-style-type: none"> <li>Main Base(8 Slots)</li> <li>Standard CPU Module(I/O: Maximum 1,024 Points)</li> <li>Internal Cnet Module, RS-232C/RS-485</li> <li>DC 24V Input, Transistor Output, 32 Contacts</li> <li>A/D Voltage Input Type(4 Channels)</li> </ul>

#### (2) Initial setting

No.	Item	Details	Internal memory address	The value to write in internal memory
1	Channel	Ch0, Ch1, Ch2	0	h0007
2	Input voltage range	0 ~ 10 V	1	h0000
3	Output data range	0 ~ 4000	2	h0000
4	Filter process	Ch 0	3	h0001
5	Ch 0 filter constant	50	4	50
6	Average process	Ch1, Ch2	12	h0006
6	Average process method	Frequency average: Ch1 Time average: Ch2	13	h0100
7	Average value	Frequency average value: 100 (times)	15	100
		Time average value: 200 (ms)	16	200

#### (3) Program flow

- (a) If Ch 0's digital value is less than 3000, Contact No. 0 (P00080) of relay output module installed on Slot No.2 will be On.
- (b) If CH 1's digital value is greater than 3200, Contact No.2 (P00082) of relay output module installed on Slot No.2 will be On.
- (c) If CH 2's digital value is greater than or equal to 3000 and less than or equal to 3200, Contact No.4 (P00086) of relay output module installed on Slot No.2 will be On.
- (d) If CH 2's digital value is equal to 3200, Contact No.5 (P00085) of relay output module installed on Slot No.2 will be On.

(4) Program

(a) Program example using [I/O Parameters]

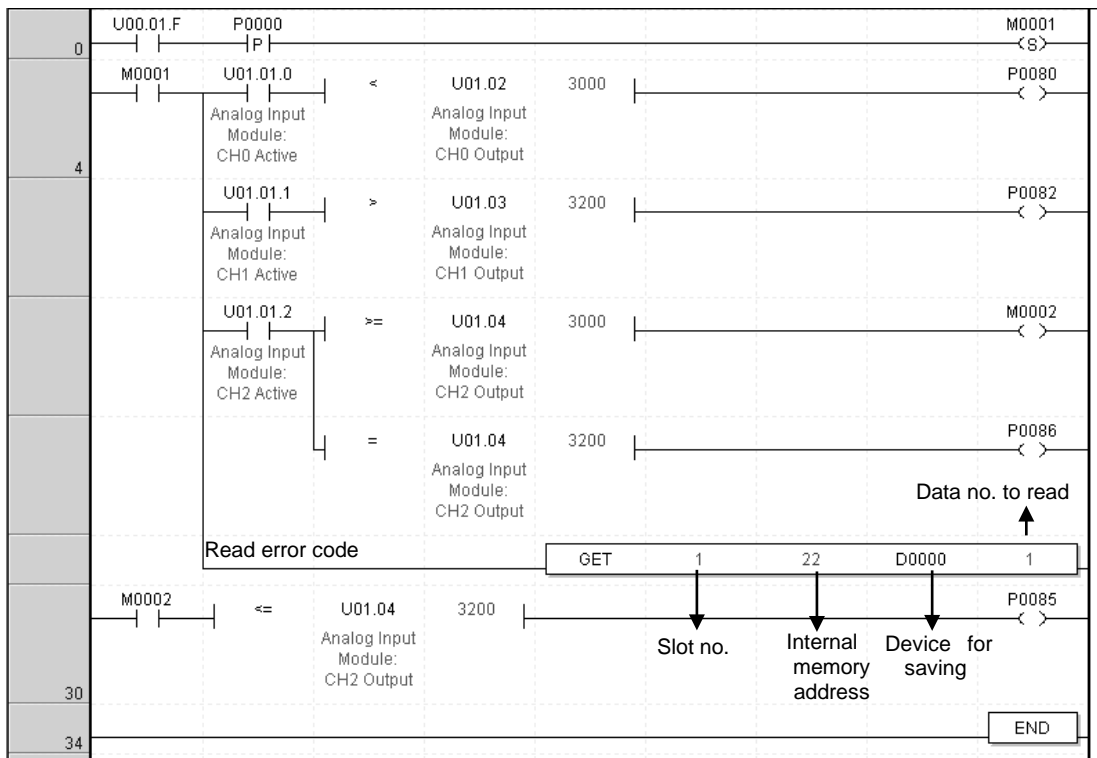
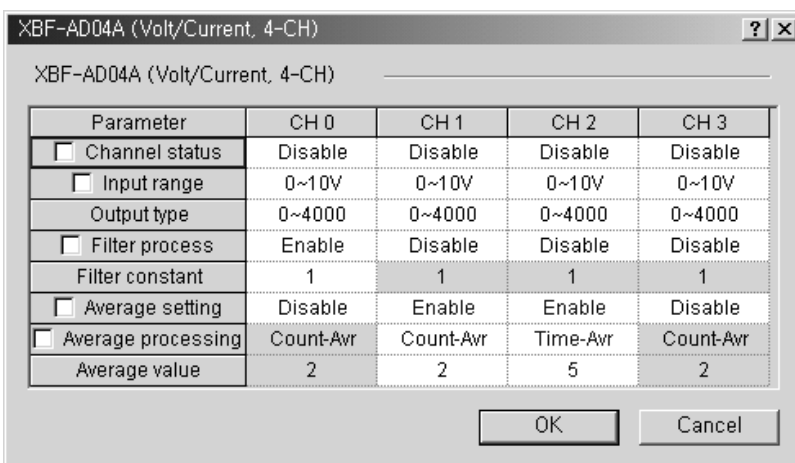
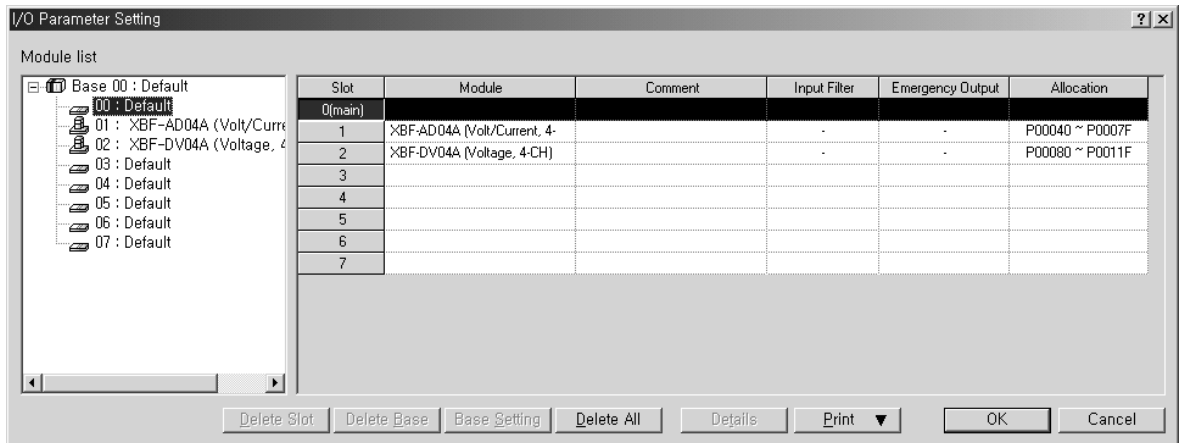

[Program in case of "S" type or "H" type]

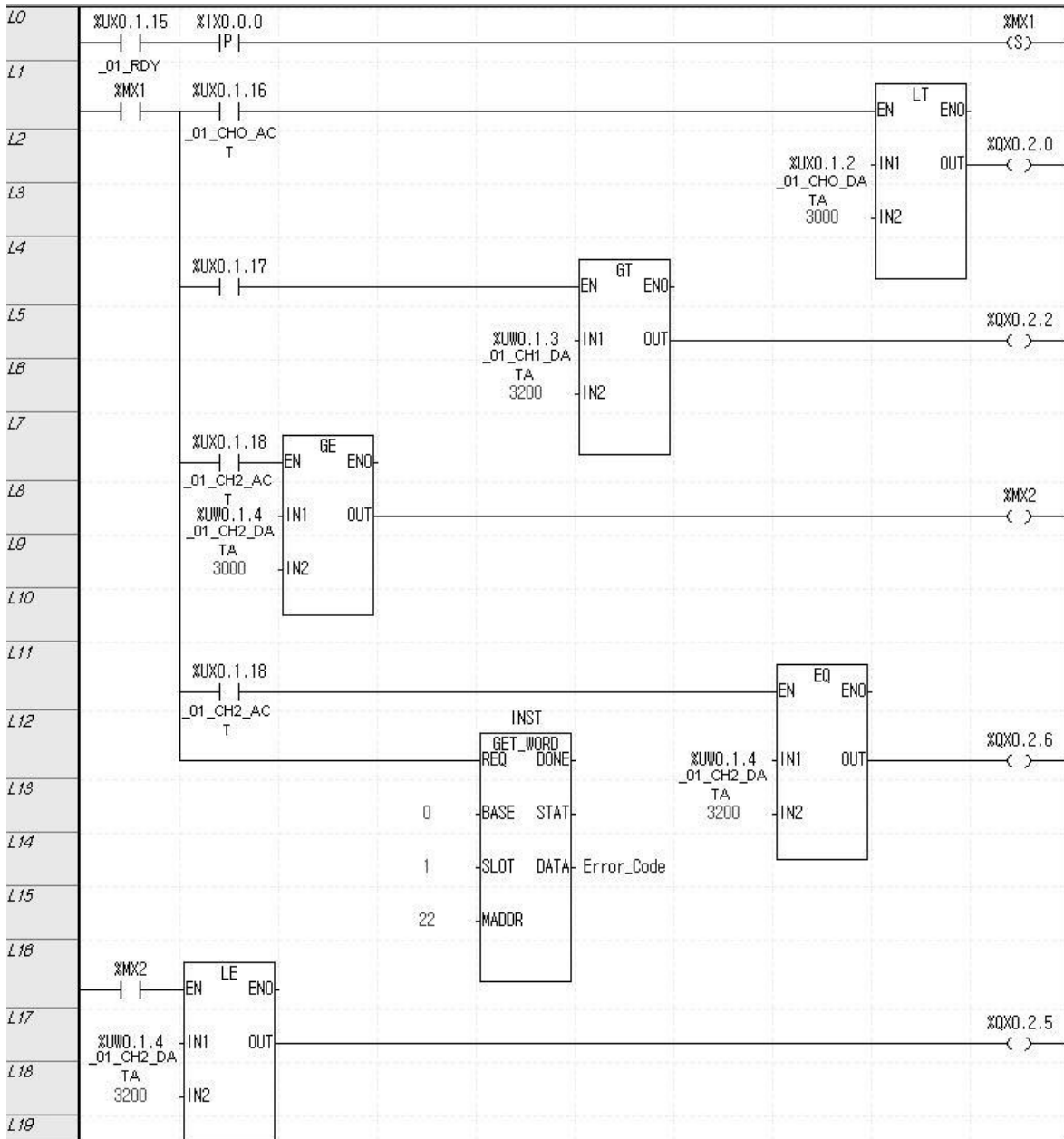

[Program in case of IEC type]



(b) Program example of PUT/GET instruction used

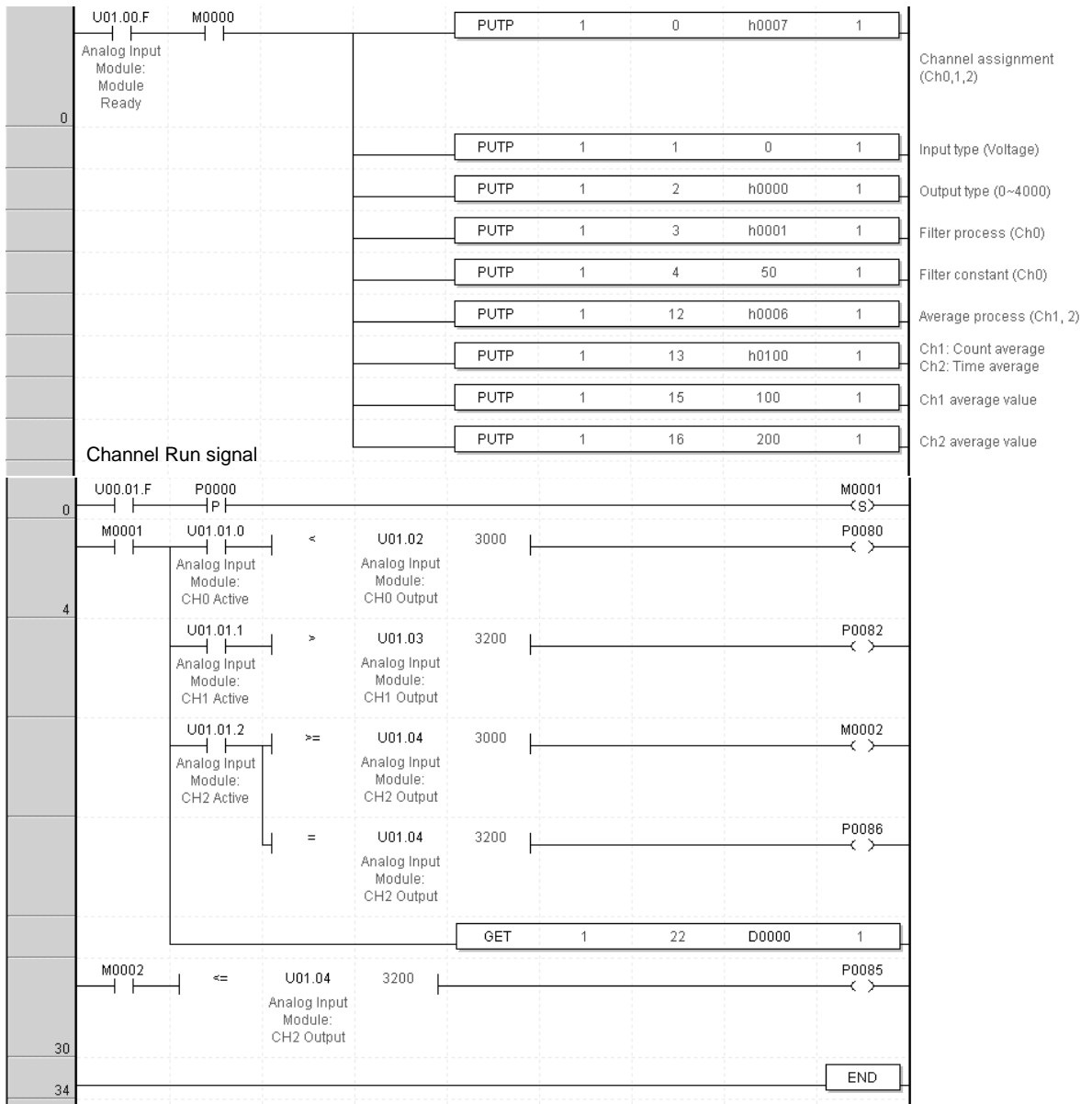

[Program in case of "S" type or "H" type]

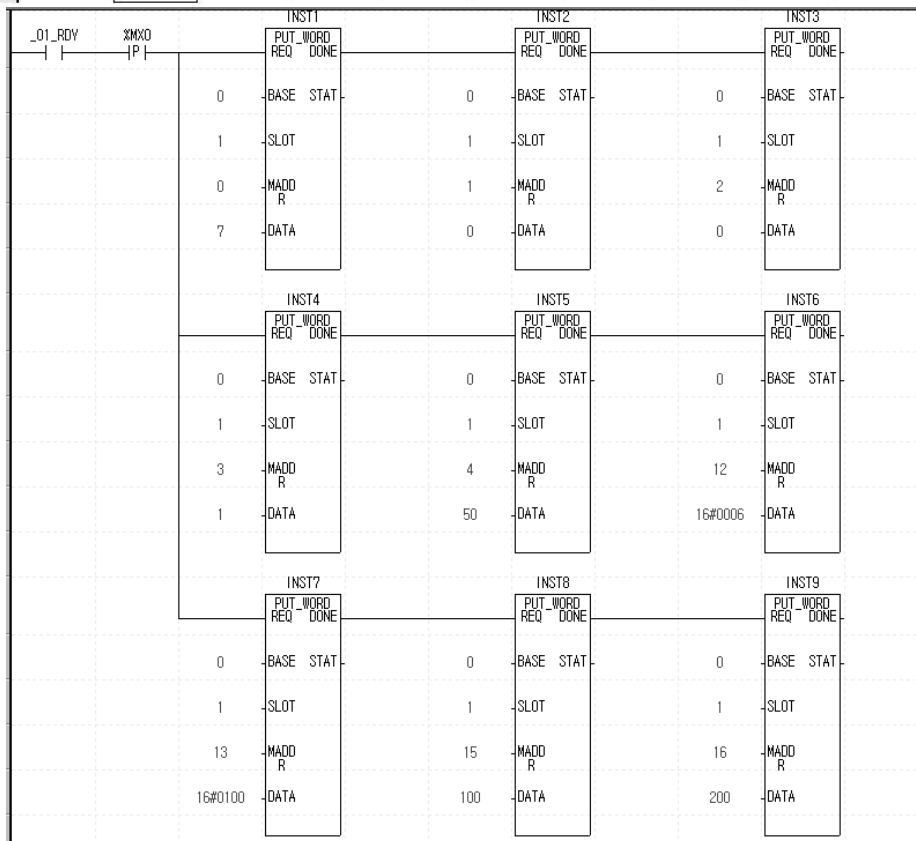
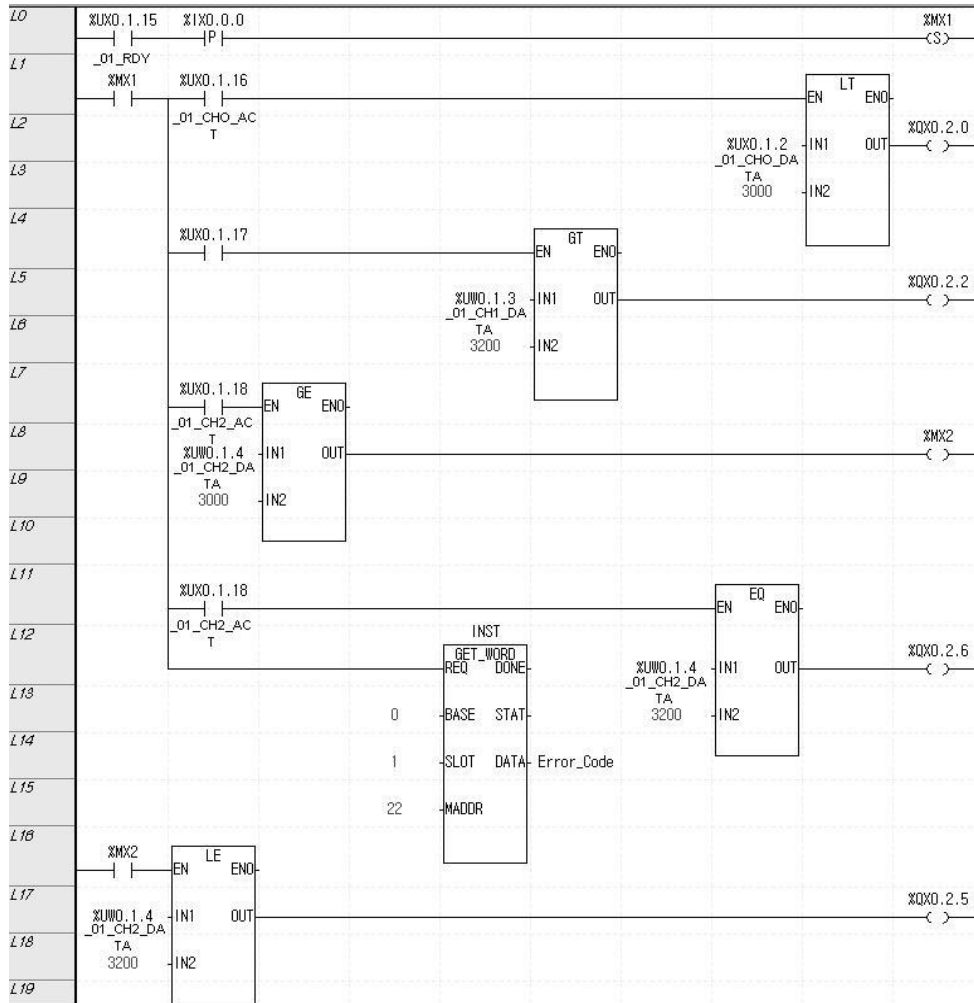

[Program in case of IEC type]

## 2.14 Troubleshooting

### 2.14.1 RUN LED flickers

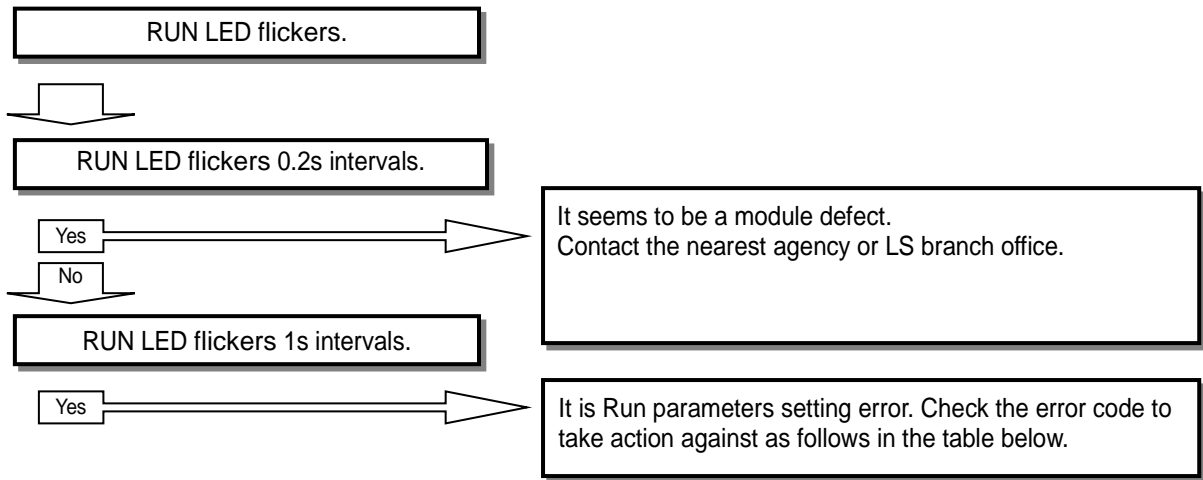

Error code (Dec.)	Error Details	Action
50#	Filter constant setting range exceeded	Change filter constant setting value within 1 ~ 99.
60#	Time average setting range exceeded	Change time average setting value within 4 ~ 16000.
70#	Frequency average setting range exceeded	Change frequency average setting value within 2 ~ 64000.

※ # indicates channel number.

2.14.2 RUN LED is off

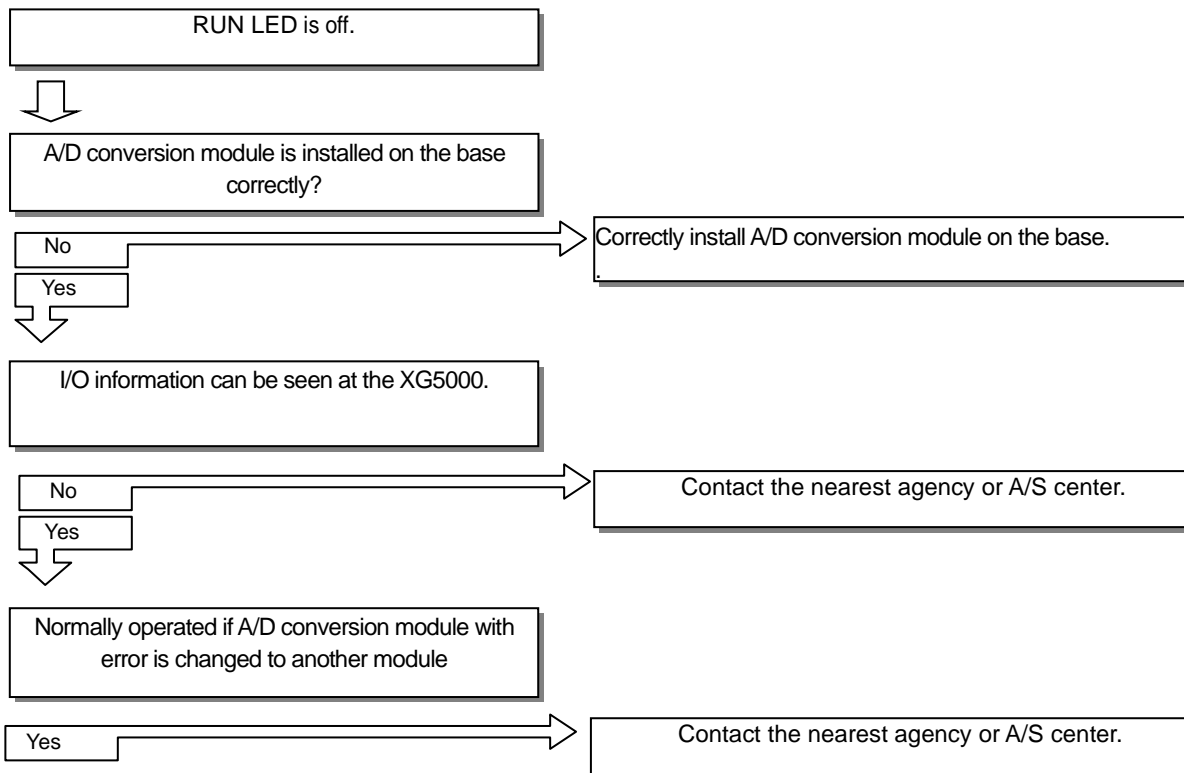

### 2.14.3 A/D conversion value is not normal

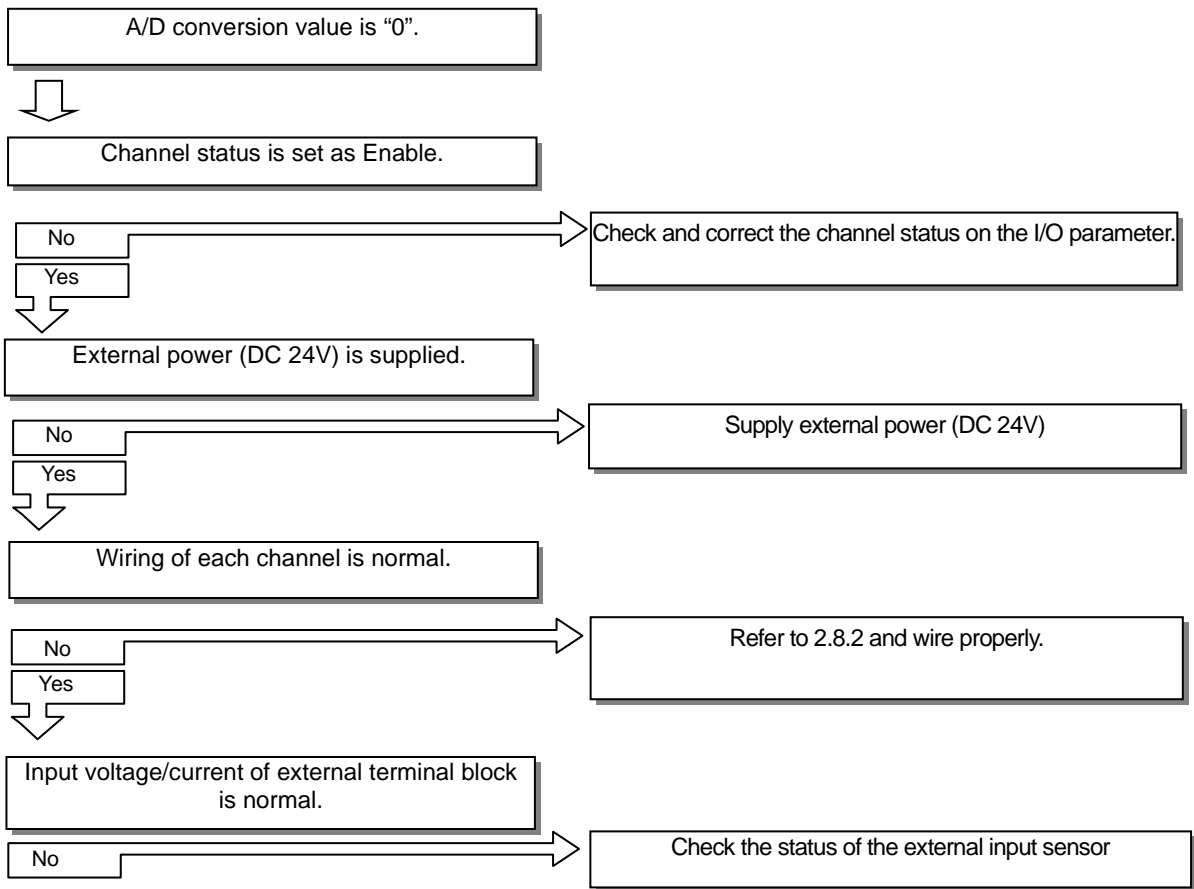

### 2.14.4 Status check of A/D conversion module through XG5000 system monitor

Module type, module information, OS version and module status of A/D conversion module can be checked through XG5000 system monitoring function.

#### 1) Execution sequence

Two routes are available for the execution.

- (1) [Monitor] -> [System Monitoring] -> And on the module screen, click the right mouse button to display [Module Information].
- (2) [Monitor] -> [System Monitoring] -> And Double-click the module screen.

#### 2) Module information

- (1) Module type: shows the information of the module presently installed.
- (2) Module information: shows the OS version information of A/D conversion module.
- (3) O/S version: shows the OS prepared date of A/D conversion module.
- (4) Module status: shows the present error code. (Refer to 7.1 for detailed error codes)

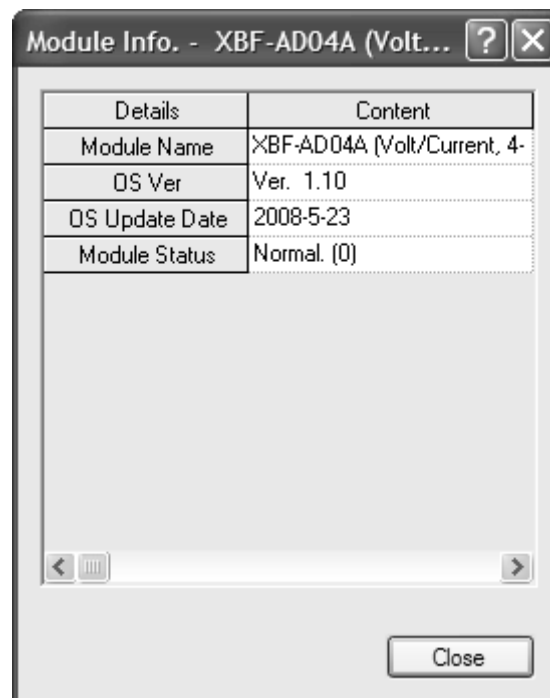

## Chapter 3 Analog Output Module

### 3.1 Setting Sequence before Operation

Before using the analog output module, follow steps below.

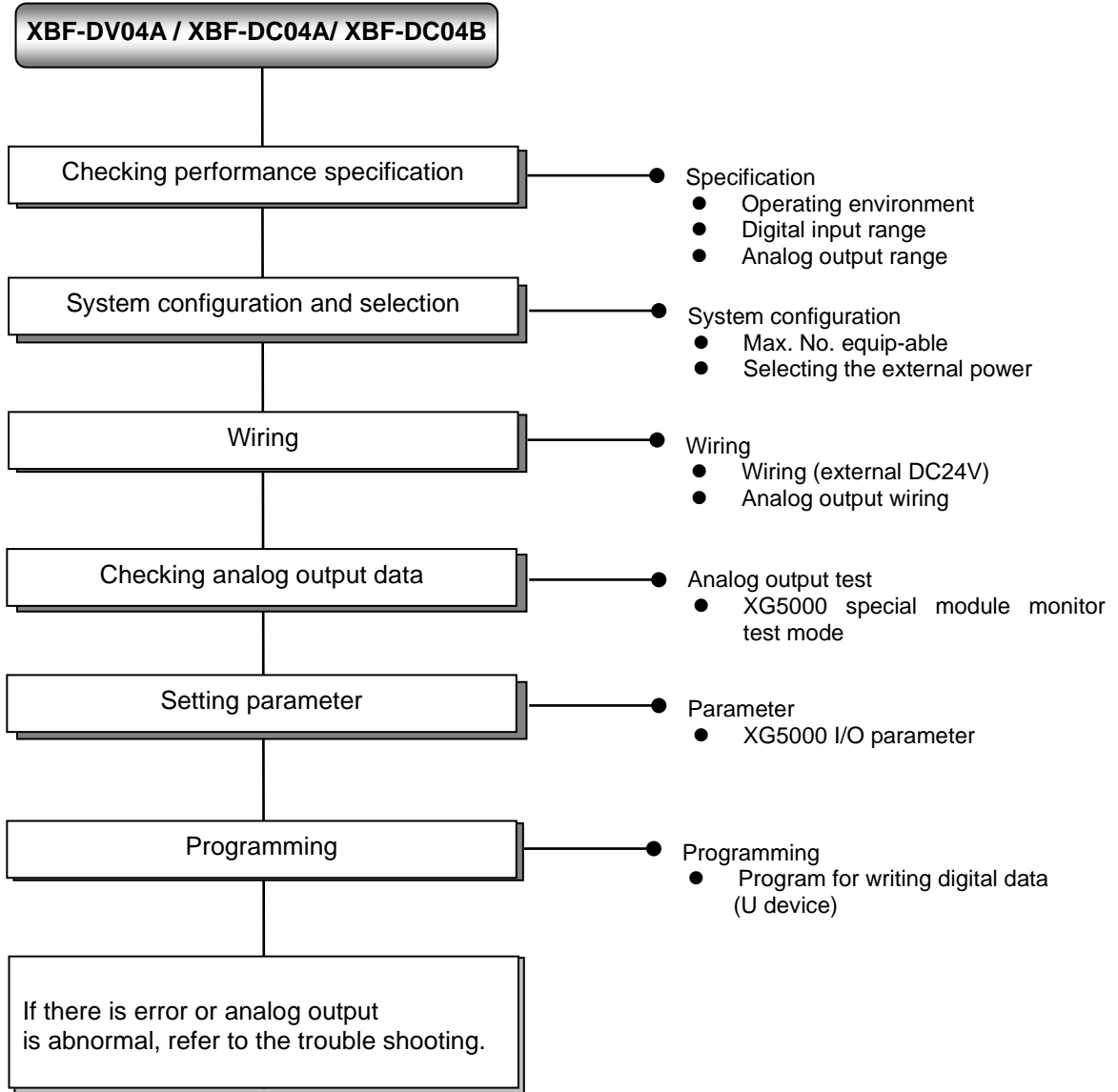

## 3.2 Specification

### 3.2.1 General specifications

Here describes general specification of analog output module.

No.	Item	Specifications	Related specifications			
1	Ambient temperature	0°C ~ +55°C	-			
2	Storage temperature	-25°C ~ +70°C	-			
3	Ambient humidity	5 ~ 95%RH (Non-condensing)	-			
4	Storage humidity	5 ~ 95%RH (Non-condensing)	-			
5	Vibration resistance	Occasional vibration		-	IEC61131-2	
		Frequency	Acceleration	Amplitude		How many times
		5 ≤ f < 8.4 Hz	-	3.5 mm		10 times each directions (X, Y and Z)
		8.4 ≤ f ≤ 150 Hz	9.8 m/s <sup>2</sup> (1G)	-		
		For continuous vibration				
		Frequency	Acceleration	Amplitude		
		5 ≤ f < 8.4 Hz	-	1.75 mm		
8.4 ≤ f ≤ 150 Hz	4.9 m/s <sup>2</sup> (0.5G)	-				
6	Shock resistance	<ul style="list-style-type: none"> <li>Peak acceleration: 147 m/s<sup>2</sup>(15G)</li> <li>Duration: 11ms</li> <li>Half-sine, 3 times each direction per each axis</li> </ul>	IEC61131-2			
7	Noise resistance	Square wave Impulse noise	AC: ± 1,500V DC: ± 900V	LS ELECTRIC standard		
		Electrostatic discharge	Voltage : 4kV (contact discharging)	IEC 61131-2, IEC 61000-4-2		
		Radiated electromagnetic field noise	80 ~ 1,000 MHz, 10V/m	IEC 61131-2, IEC 61000-4-3		
		Fast transient /bust noise	Segment Voltage	Power supply module 2kV	Digital/analog input/output communication interface 1kV	IEC 61131-2, IEC 61000-4-4
8	Environment	Free from corrosive gasses and excessive dust	-			
9	Altitude	Up to 2,000 ms	-			
10	Pollution degree	Less than equal to 2	-			
11	Cooling	Air-cooling	-			



### 3.2.2 Performance specifications

Here describes performance specification of analog output module.

Item		Specification			
		XBF-DV04A	XBF-DC04A	XBF-DC04B	
Analog output	Type	Voltage	Current	Current	
	Range	DC 0 ~ 10V (Load resistance: 2kΩ or more)	DC 4 ~ 20mA DC 0 ~ 20mA (Load resistance: 510Ω or less)	DC 0 ~ 1.2mA (Load resistance: 510Ω or less)	
Digital input	Type	12-bit binary data			
	Range	Signed value	0 ~ 4000	0 ~ 4000	0 ~ 4000
		Unsigned value	-2000 ~ 2000	-2000 ~ 2000	-2000 ~ 2000
		Precise value	0 ~ 1000	400 ~ 2000/0 ~ 2000	0 ~ 1,200
		Percentile value	0 ~ 1000	0 ~ 1000	0 ~ 1,000
Maximum resolution		2.5mV (1/4000)	5μA (1/4000)	0.3μA (1/4000)	
Accuracy		±0.5% or less			
Maximum conversion speed		1 ms/channel			
Absolute maximum output		DC ±15V	DC +25 mA		
Number of maximum channel		4 channels			
Insulation method		Photo-coupler insulation between input terminal and PLC power (no insulation between channels)			
Terminal connected		11-point terminal block			
I/O points occupied		Fixed type: 64 points			
Max. no. of installation		7 [When using XBM-Dxxx□ (□: "S", "H", "H2", "HP") type] 7 (when using XB(E)C-DxxxSU type) 10 (when using XB(E)C-DxxxH type or XB(E)C-DxxxU type) Not Available (when using XB(E)C-DxxxE type)			
Current consumption	Internal (DC 5V)	110mA	110mA		
	External (DC 21.6 ~26.4V)	70mA	120mA		
Weight		64g	70g		

#### Remark

Offset and gain about analog output range have been set at the factory and the user can change them.

3.3 Designations and Functions

Here describes designation and functions.

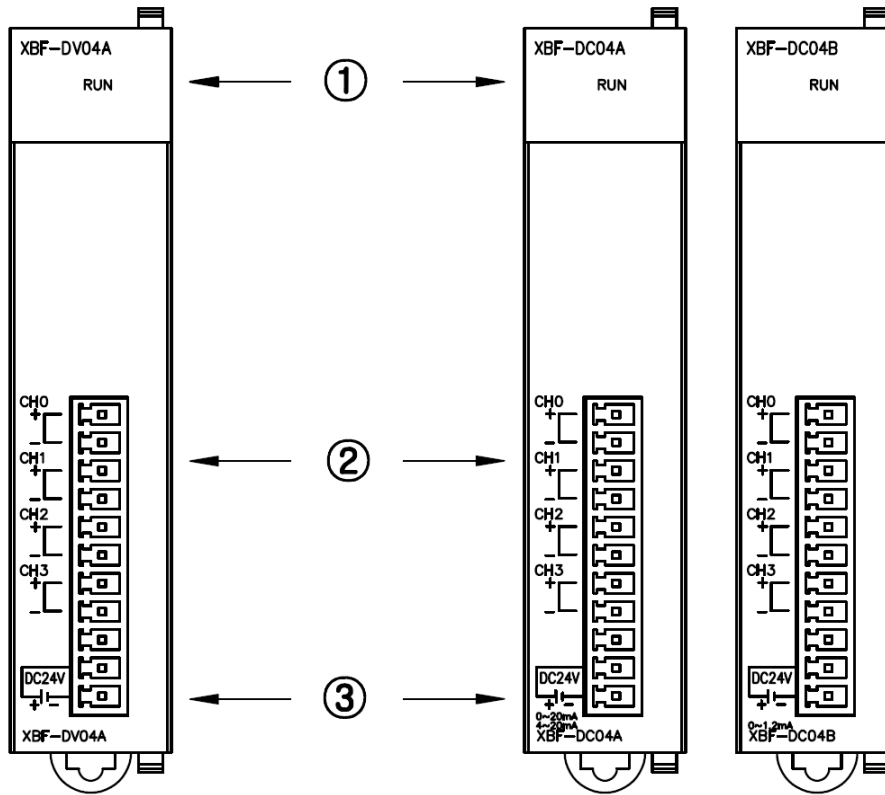

No.	Description
①	<p>RUN LED</p> <p>It displays the operation status of D/A conversion module</p> <ul style="list-style-type: none"> <li>- On: Normal operation status</li> <li>- Flickering: Error occurred</li> <li>- Off: Power off or abnormal status of the module</li> </ul>
②	<p>Analog output terminal (Voltage, Current)</p> <p>It is an output terminal to connect an analog output (Voltage, Current) of each channel to external machinery and tools.</p>
③	<p>External power input terminal</p> <p>It is an external DC 24V input terminal that supplies power for an analog output (voltage, current).</p>

### 3.4 Characteristic of I/O Conversion

Characteristic of I/O conversion converts a digital input into an analog output (voltage, current) and displays a straight line with the gradient as shown below. The range of digital input is shown with Unsigned Value, Signed Value, Precise Value, and Percentile Value such as the graph below.

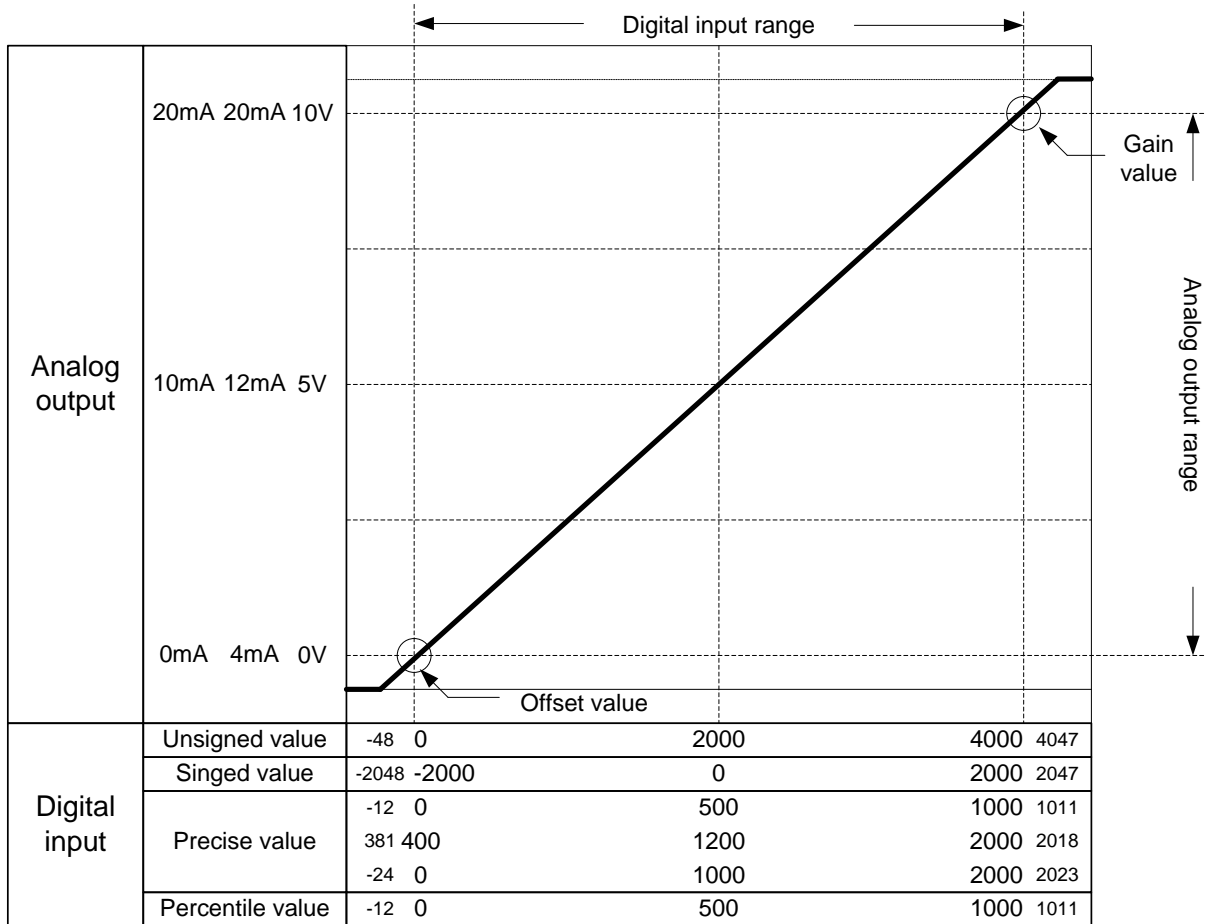

### 3.5 Characteristic of Input/Output

The range of a voltage output is DC 0 ~ 10V and a current output is DC 4 ~ 20mA / DC 0 ~ 20mA.

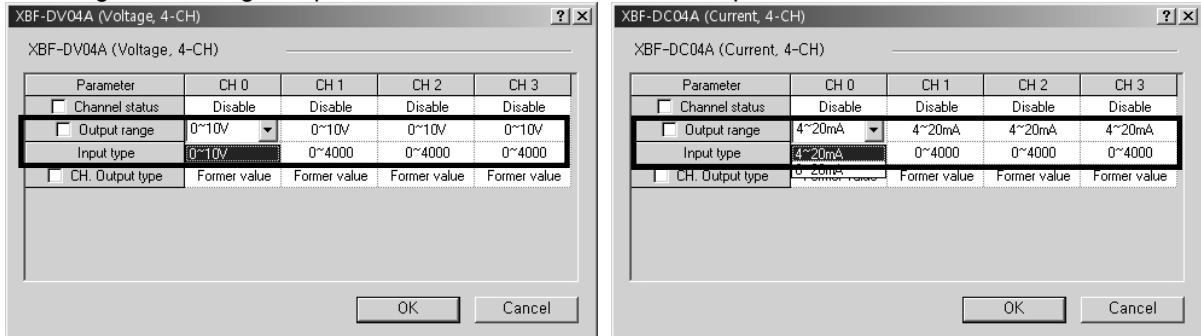

Digital input value toward analog voltage output is shown below.

Resolution: 2.5mV (1/4000), Accuracy: within  $\pm 0.5\%$

The range of digital input	Analog voltage output						
	under 0V	0V	2.5V	5V	7.5V	10V	over 10V
Unsigned value (-48 ~ 4047)	under 0	0	1000	2000	3000	4000	over 4000
Signed value (-2048 ~ 2047)	under -2000	-2000	-1000	0	1000	2000	over 2000
Precise value (-12 ~ 1011)	under 0	0	250	500	750	1000	over 1000
Percentile value (-12 ~ 1011)	under 0	0	250	500	750	1000	over 1000

Digital input value toward analog current output is shown below.

Resolution: 5μA (1/4000), Accuracy: within  $\pm 0.5\%$

The range of digital input	Analog current output						
	under 4mA	4mA	8mA	12mA	16mA	20mA	over 20mA
	under 0mA	0mA	5mA	10mA	15mA	20mA	over 20mA
Unsigned value (-48 ~ 4047)	under 0	0	1000	2000	3000	4000	over 4000
Signed value (-2048 ~ 2047)	under -2000	-2000	-1000	0	1000	2000	over 2000
Precise value (381 ~ 2018, -24 ~ 2023)	under 400	400	800	1200	1600	2000	over 2000
	under 0	0	500	1000	1500	2000	over 2000
Percentile value (-12 ~ 1011)	under 0	0	250	500	750	1000	over 1000

### 3.6 Accuracy

Though the range of input is changed, the accuracy for the analog output values doesn't change. The range of accuracy is displayed at the ambient temperature of  $25 \pm 5 \text{ }^\circ\text{C}$  if you select unsigned value as your range of the digital input. The accuracy is satisfied  $\pm 0.5\%$ .

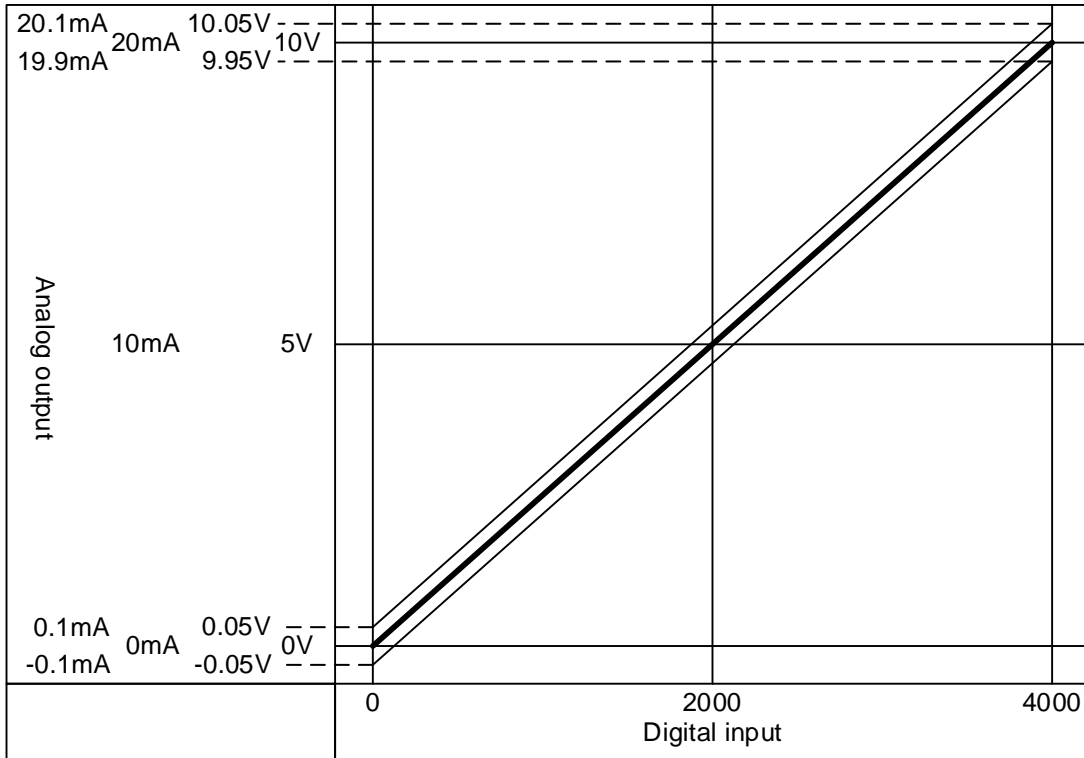

(1) Accuracy in case of 5V output

$$4000 \times 0.5\% = 20$$

in case of 5V output, accuracy range is

$$(5V - 20 \times 0.0025V) \sim (5V + 20 \times 0.0025V) = 4.95V \sim 5.05V$$

(2) Accuracy in case of 10V

$$4000 \times 0.5\% = 20$$

in case of 10V output, accuracy range is

$$(10V - 20 \times 0.0025V) \sim (10V + 20 \times 0.0025V) = 9.95 \sim 10.05$$

### 3.7 Functions of Analog Output Module

Here describes functions of XBF-DV04A/DC04A module.

Function	Details
Operation channel	<ol style="list-style-type: none"> <li>1) It sets up Run/Stop of a channel that will operate an analog output.</li> <li>2) You can save the time of whole operation by stopping unused channels.</li> </ol>
The range of output	<ol style="list-style-type: none"> <li>1) It sets up the range of an analog output.</li> <li>2) Analog voltage output module offers one range of output (DC 0 ~ 10V) and analog current output module offers two (DC 4 ~ 20mA, DC 0 ~ 20mA).</li> </ol>
The range of input data	<ol style="list-style-type: none"> <li>1) It sets up the range of a digital input.</li> <li>2) It offers four ranges of a digital input.</li> </ol>
The status of channel output	<ol style="list-style-type: none"> <li>1) It sets up the output status of a channel when it switches Run to Stop.</li> <li>2) It offers four types of output status.</li> </ol>

### 3.8 Wiring

#### 3.8.1 Precautions for wiring

- (1) Use separate cable of an A.C. power line and an external output signal of an analog output module to prevent a surge or inductive noise from the A.C. side.
- (2) Select the cable with consideration of an ambient temperature and a permitted current limit. It is recommended over AWG22 (0.3mm<sup>2</sup>).
- (3) Don't let the cable at close range to hot devices or materials. And don't bring it into contact with oil for a long time. These are the factors of a short circuit occurs unusual operation or damages devices.
- (4) Check the polarity before external power is supplied to the terminal.
- (5) It may produce inductive hindrance that is a cause of unusual operations or defects if you wire the cable with a high-voltage line or a power line.

#### 3.8.2 Wiring example

(1) Wiring example for analog voltage output module

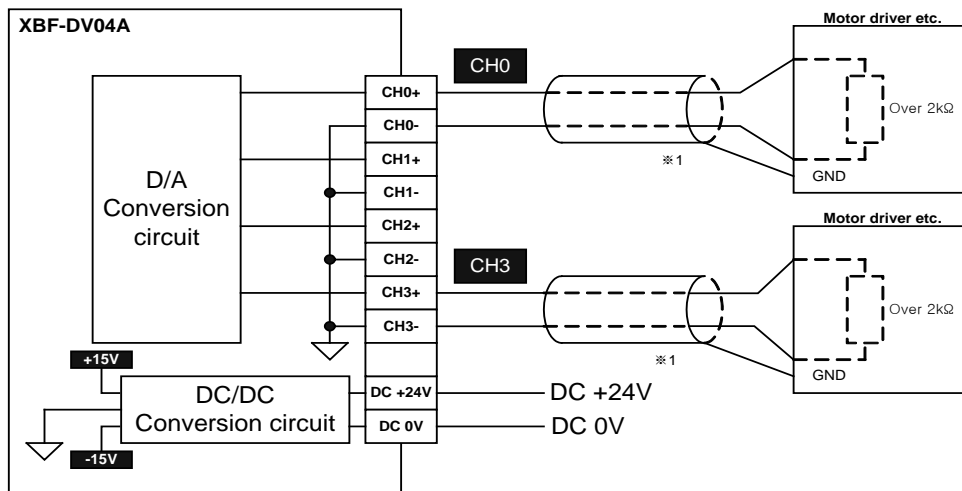

(2) Wiring example for analog current output module

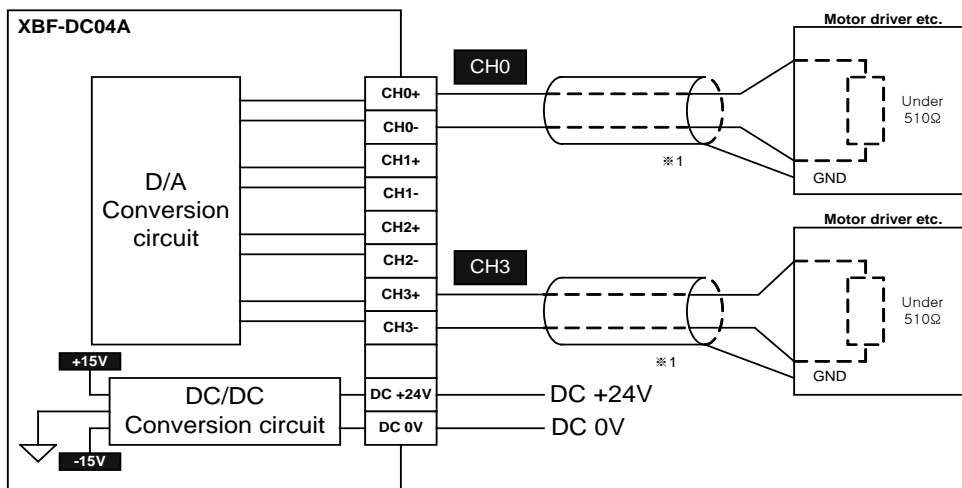

※1: Use a 2-core twisted shielded wire.

※2: The (-) terminals of the channel should be separated from each other. It may cause malfunction.

**Caution**

Current output module(XBF-DC04A) can not be connected with device which is grounded with common line. Because it is not normal current output.

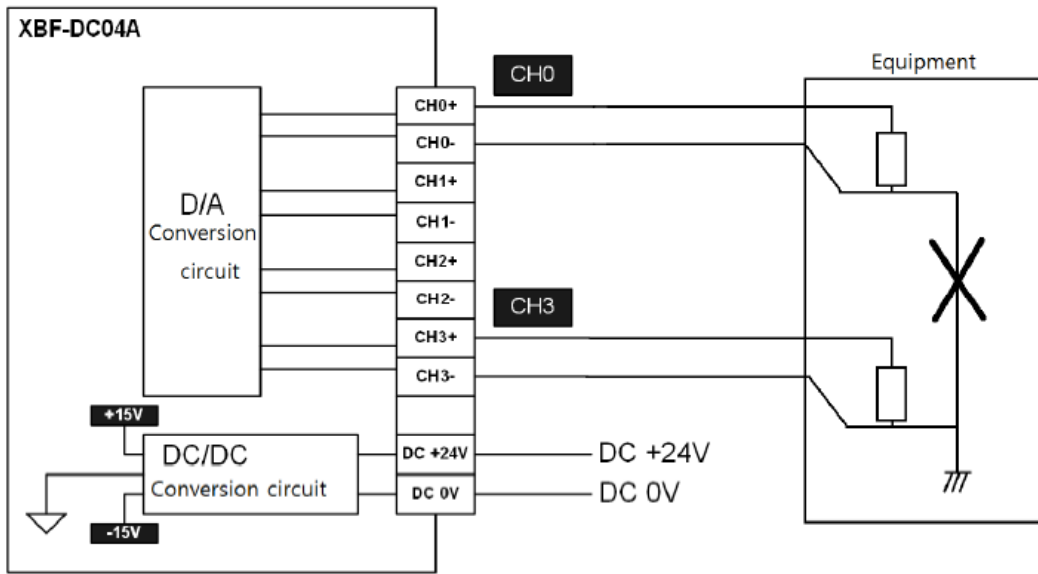



### 3.9 Operation Parameter Setting

You can specify operation parameters of the analog output module through [I/O parameters] menu in XG5000.

(1) Setting items

For the user’s convenience, XG5000 provides GUI (Graphical User Interface) for parameters setting of analog voltage/current output module.

Followings are available through [I/O parameters] on the XG5000 project window.

Item	Details
[I/O Parameters]	(1) It specifies the following items for the module operation. <ul style="list-style-type: none"> <li>- Channel Enable/Disable</li> <li>- Analog output range</li> <li>- Input type</li> <li>- Channel output type</li> </ul> (2) After the parameters that user specified in XG5000 are downloaded, they will be saved to a flash memory in the CPU unit..

(2) How to use [I/O Parameters] menu

(a) Run XG5000 to create a project. (Refer to XG5000 program manual for details on how to create the project)

(b) Double-click [I/O Parameters] on the project window.

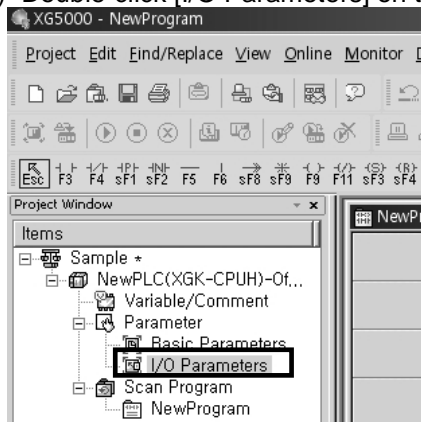

(c) Click the slot of the base that contains analog output module in the [I/O Parameter Setting] window. In the example, the analog output module is contained in the slot 1.

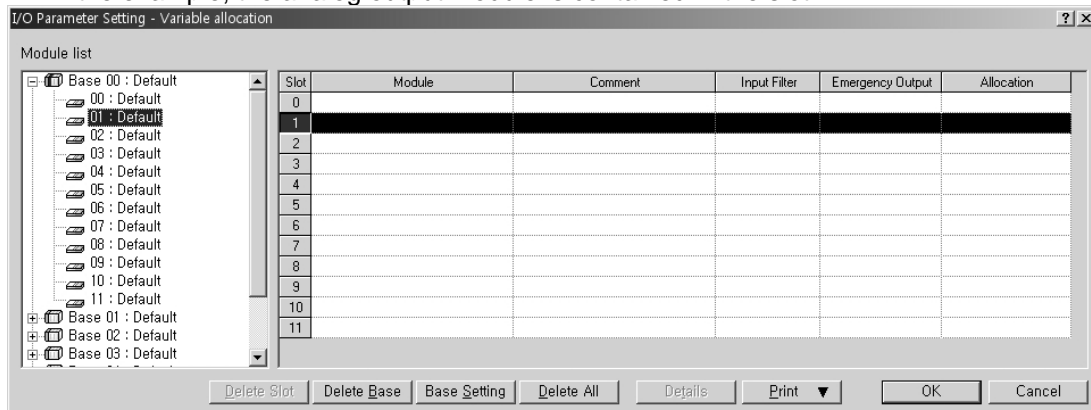

## Chapter 3 Analog Output (XBF-DV04A/DC04A/DC04B)

(d) Click the arrow button then you can see the menu to choose the applicable module. Select the applicable module.

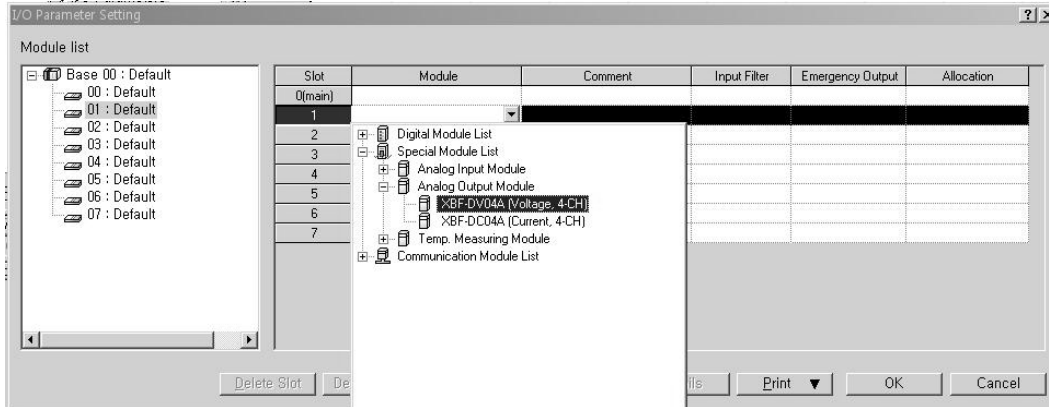

(e) Double-click the applicable slot that is selected for the parameters setting or click [Details].

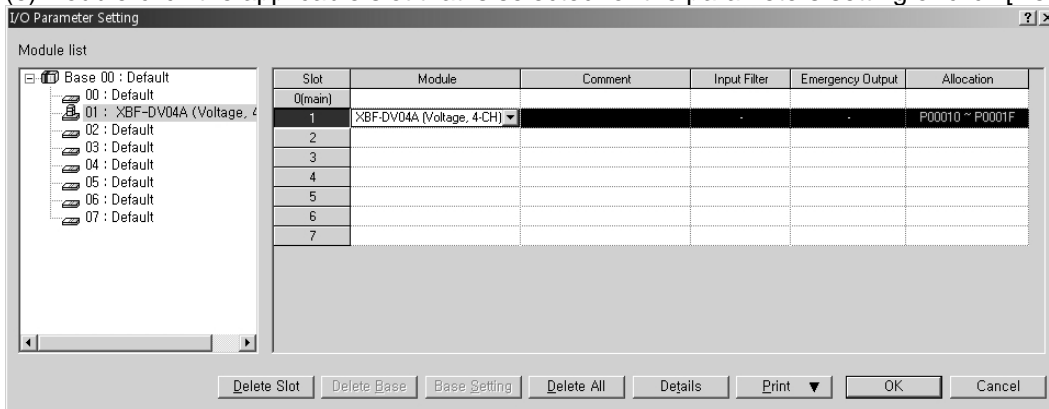

(f) A screen will be displayed for you to specify parameters for respective channels as shown below. Click a desired item to display parameters to set for respective items.

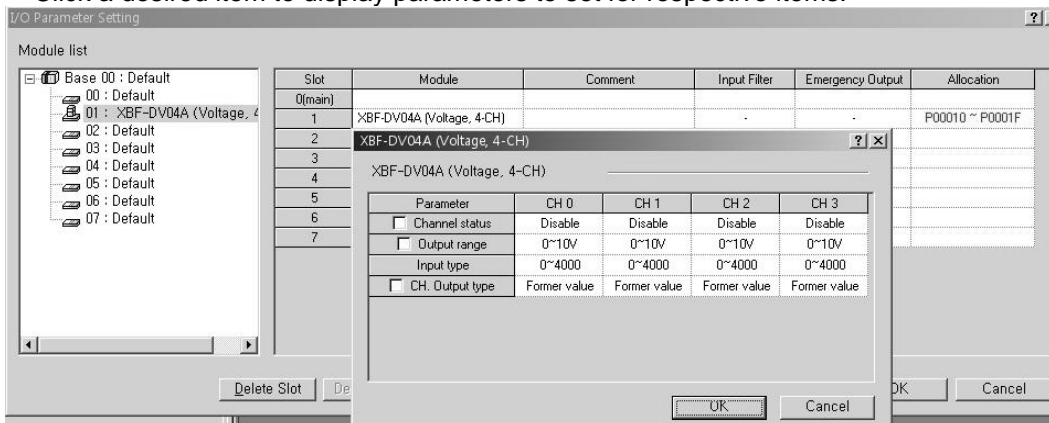

### 3.10 Special Module Monitoring Function

You can start to test the analog output module connecting by [Online] → [Connect] and then click [Monitor] → [Special Module Monitoring] menu in XG5000.

**Remark**

- 1) If the program is not displayed normally because of insufficient system resource, you may start XG5000 again after close the program and other applications.
- 2) I/O parameters those are specified in the state of [Special Module Monitoring] menu are temporarily set up for the test. They will be disappeared when the [Special Module Monitoring] is finished.
- 3) Testing of [Special Module Monitoring] is the way to test the analog output module. It can test the module without a sequence program.

#### 3.10.1 How to use special module monitoring

Special module monitoring function is described below based on the analog voltage output module (XGF-DV04A).

- (1) Start of [Special Module Monitoring]  
Go through [Online] → [Connect] and [Monitor] → [Special module Monitoring] to start. If the status is not online, [Special Module Monitoring] menu will not be activated.

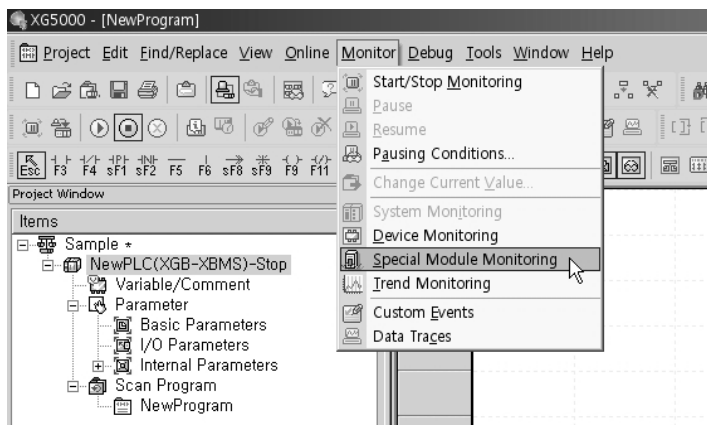

- (2) How to use [Special Module Monitoring]
  - (a) Connecting XG5000 with PLC basic unit, [Special Module List] window will show base/slot information and types of special module by click [Monitor] → [Special Module Monitoring]. Special Module List will display the modules that are installed in PLC now.

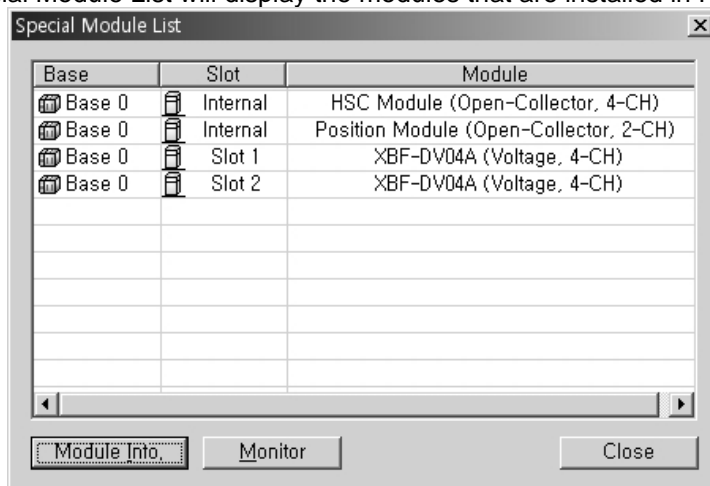

### Chapter 3 Analog Output (XBF-DV04A/DC04A/DC04B)

- (b) Select a special module then click [Module Info.] button to display the information as described below.

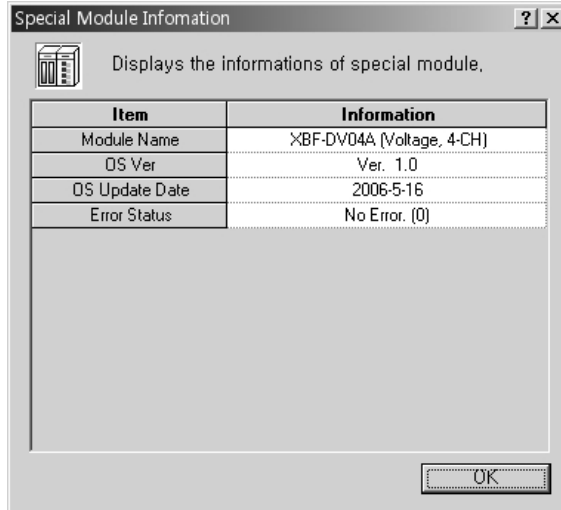

- (c) Click [Monitor] button in the [Special Module List] window to display the [Special Module Monitor] window as below

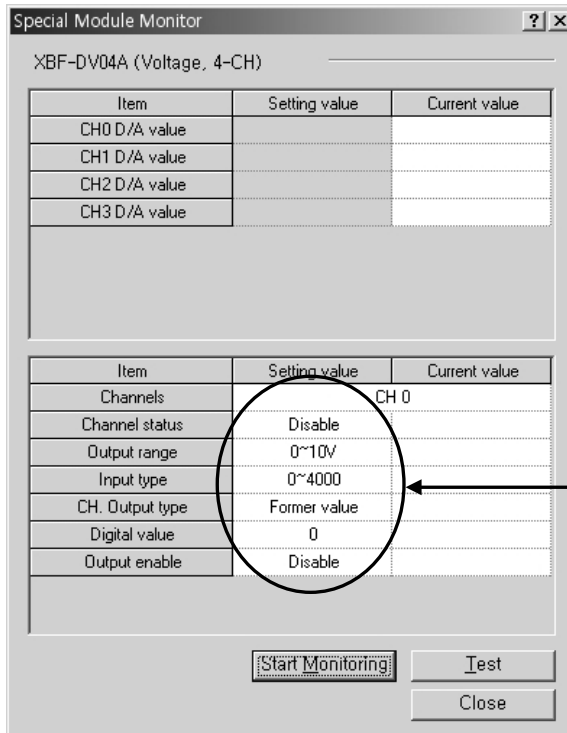

(d) [Start Monitoring] button will show you digital input data of the operating channel.

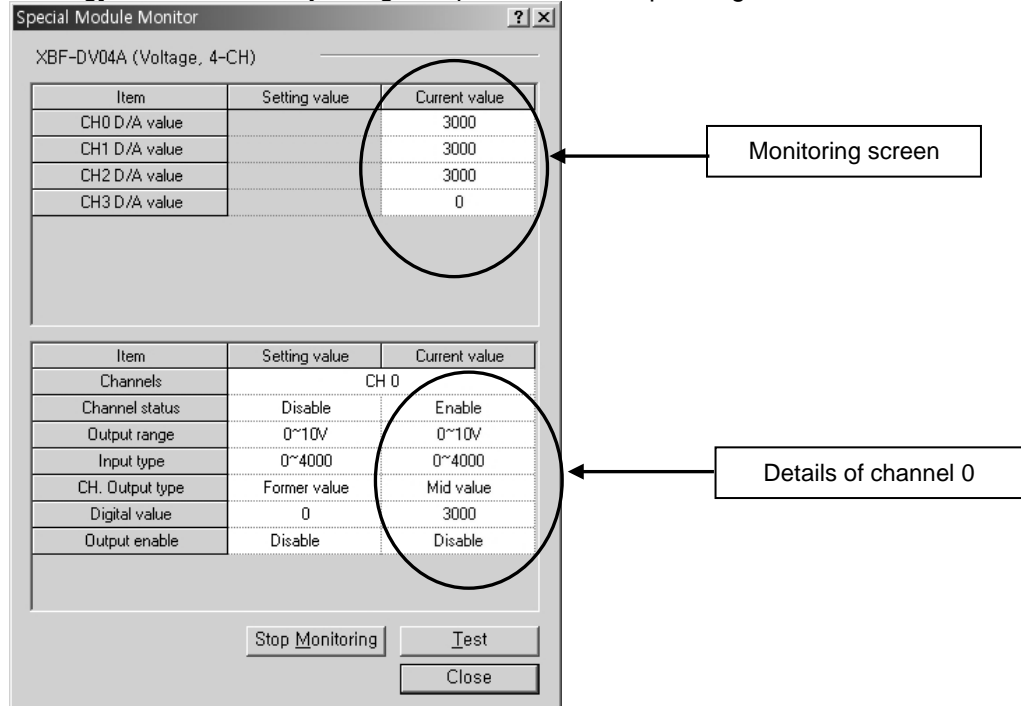

(e) [Test] is used to change the parameters of the voltage output module. You can change the parameters when you click the values at the bottom of the screen. It is only available when XGB CPU unit's status is in [Stop Monitoring].

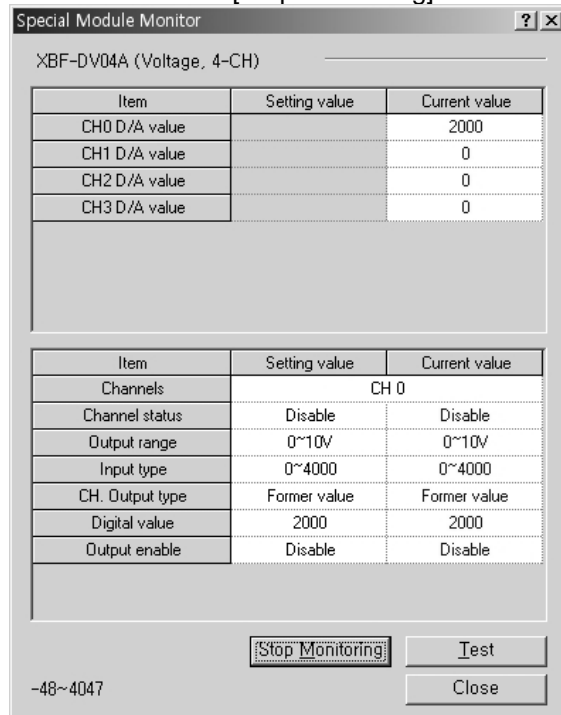

(f) [Close] is used to escape from the monitoring/test screen.

### 3.11 Register U devices (special module variable)

Register the variables for each module referring to the special module information that is set in the I/O parameter. The user can modify the variables and comments.

(1) Registration sequence

(a) Select a special module type in [I/O Parameter Setting] window.

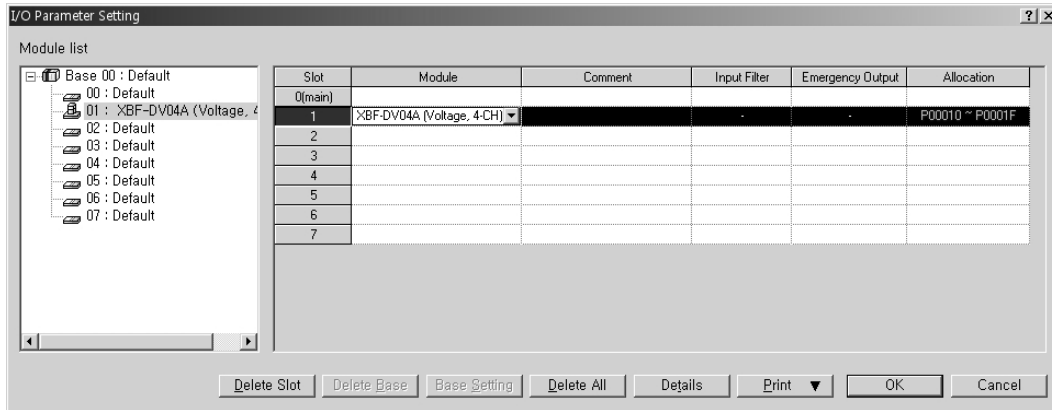

(b) Double-click [Variable/Comment] from the project window.

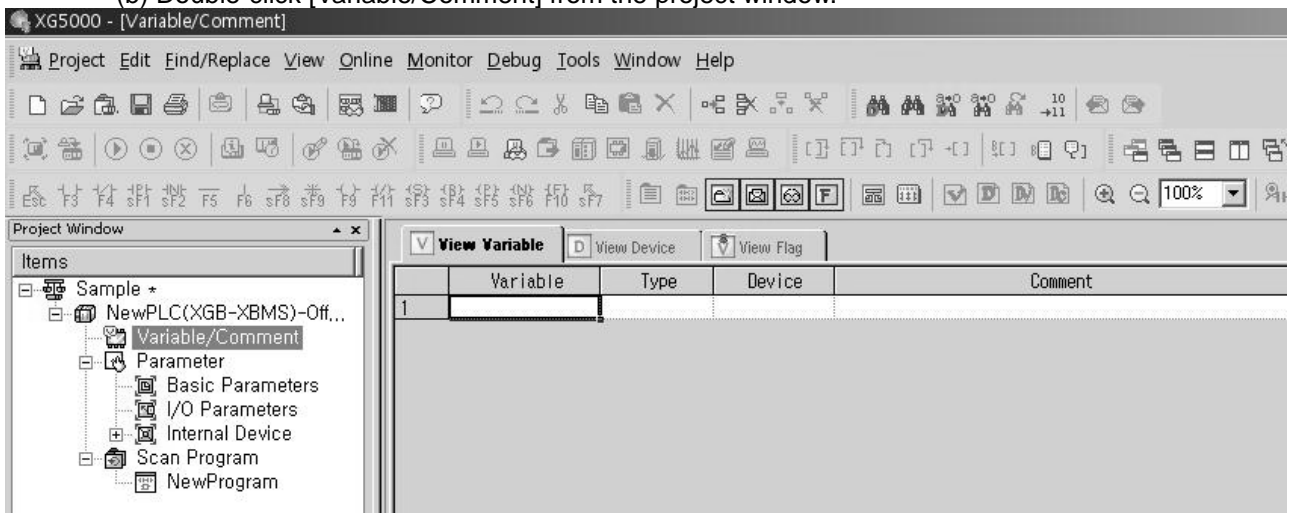

(c) Select [Edit] → [Register U Device].

In case of IEC, select [Edit] → [Register special module variable]

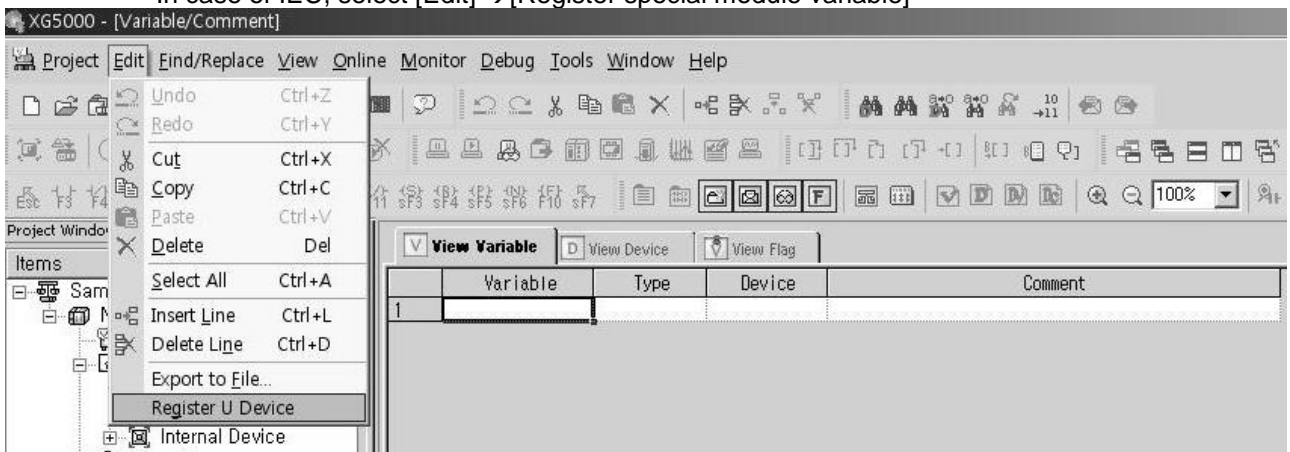



(d) Click 'Yes'.

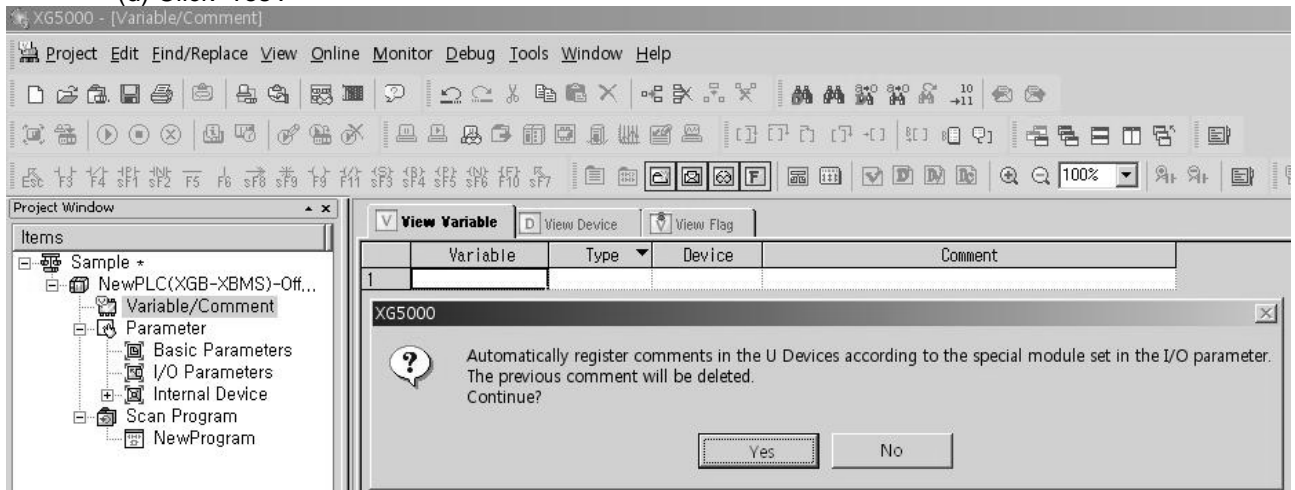

(e) As shown below, the variables are registered.

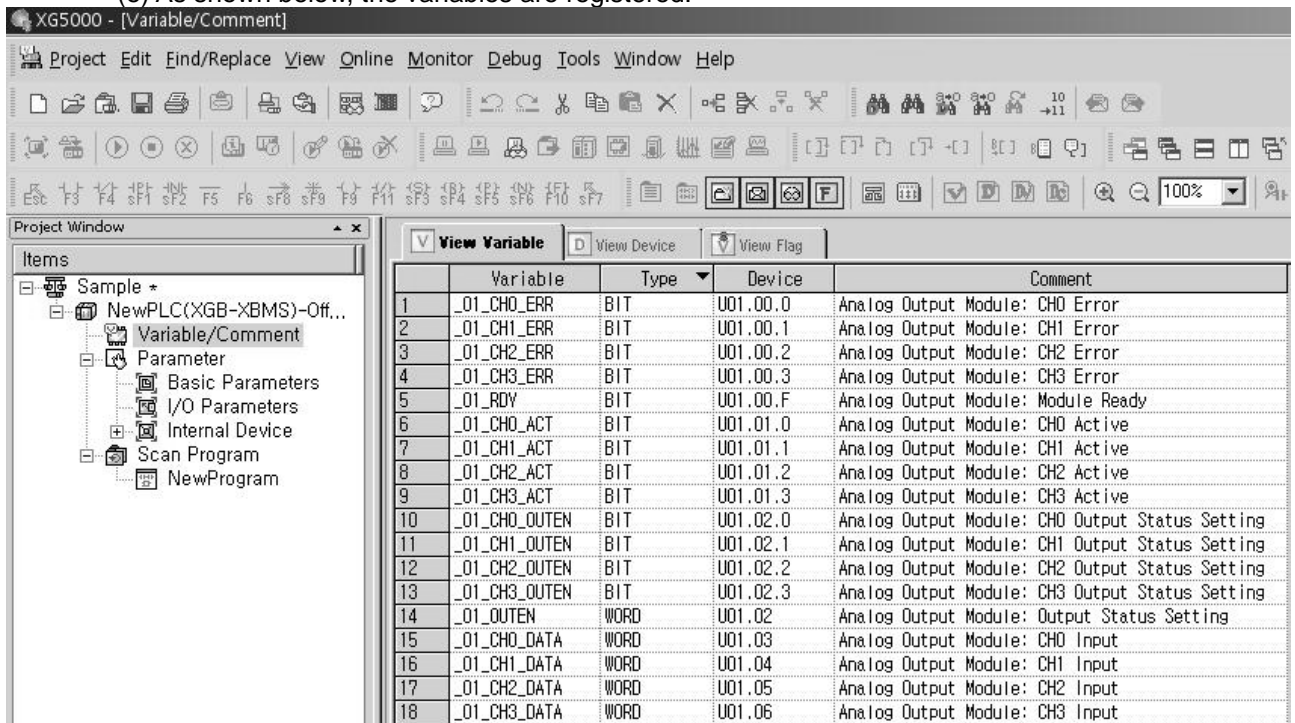

(2) Save variables

- (a) The contents of 'View Variables' can be saved as a text file
- (b) Click [Edit] → [Export to File].
- (c) The contents of 'View Variable' are saved as a text file.

(3) View variables in a program

- (a) The example of XG5000 is shown below.

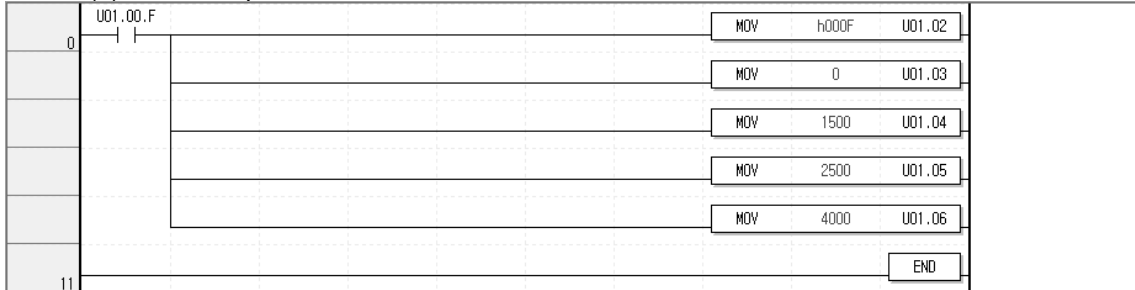

- (b) Select [View] → [Variables]. The devices are changed into variables.

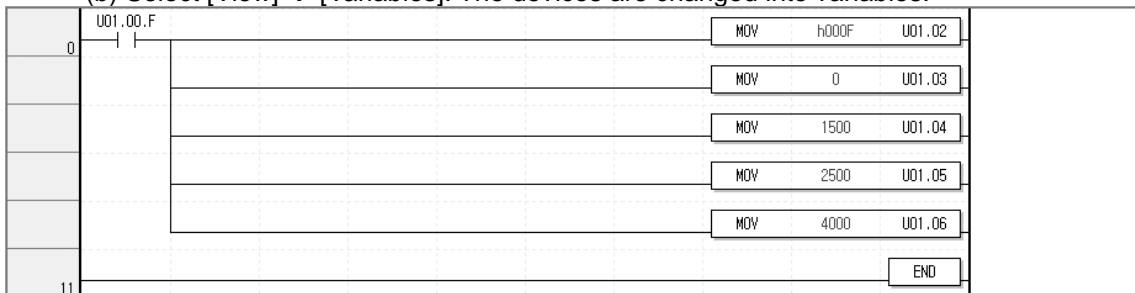

- (c) Select [View] → [Devices/Variables]. Device and variable both are displayed.

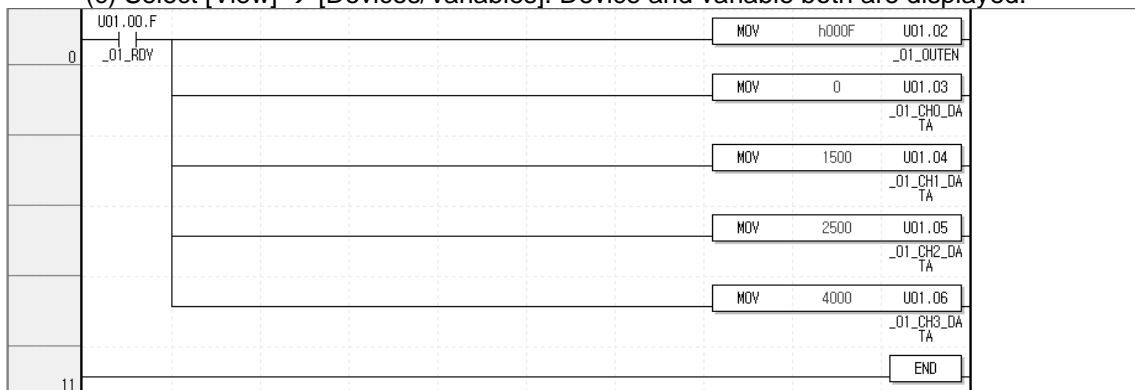



(d) Select [View] → [Devices/Comments]. Device and comment both are displayed.

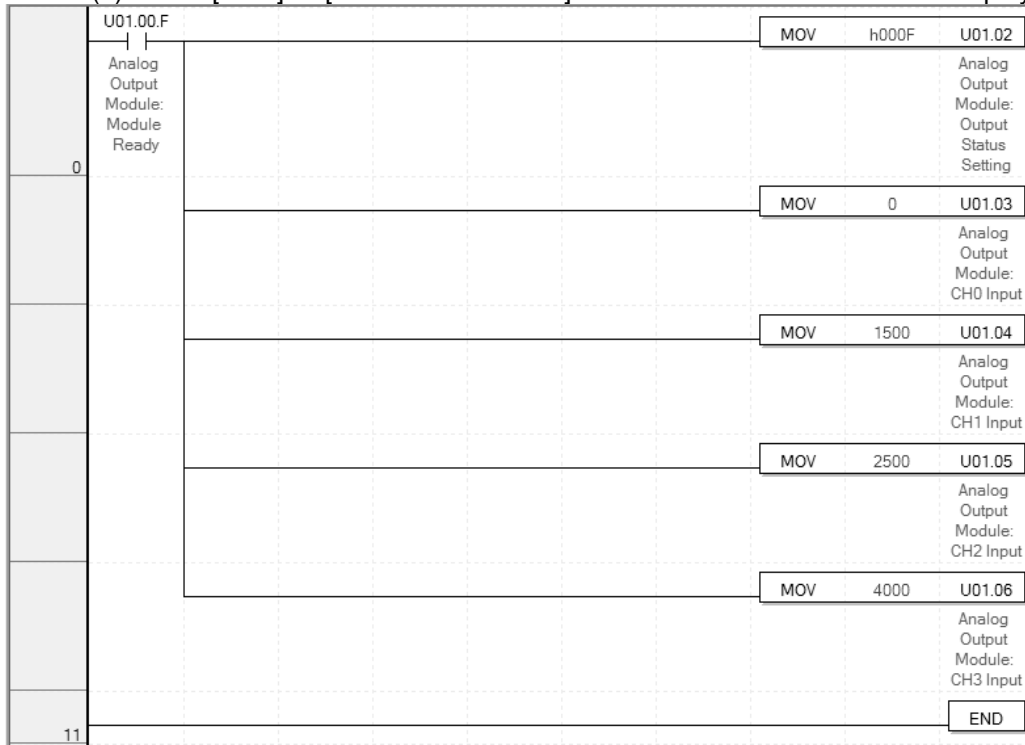

### 3.12 Internal memory

Describes configuration and function of internal memory

#### 3.12.1 Data I/O area

Describes data I/O area of analog output module

Address ('s', 'h' type)	Address (IEC type)	Description	Details	Remarks
U0x.00	%UW0.x.0	Module Ready / Error	F(15) Bit On(1): Module Ready 0~3 Bit On(1): Channel Error	Read available
U0x.01	%UW0.x.1	CH operation information	Bit On(1): Channel Run Bit Off(0): Channel Stop	
U0x.02	%UW0.x.2	Output setting	Bit On(1): Output Allow Bit Off(0): Output Forbid	Read/Write available
U0x.03	%UW0.x.3	CH0 digital input value	12-bit binary data	
U0x.04	%UW0.x.4	CH1 digital input value		
U0x.05	%UW0.x.5	CH2 digital input value		
U0x.06	%UW0.x.6	CH3 digital input value		

※ In the device assignment, x stands for a slot number that the module is installed

- (1) Module Ready/Channel Error information ( ( ) means deice name of IEC type)
- (a) U0x.00.F (%UX0.x.15): It will be ON when XGB CPU unit is powered or reset with the condition that an analog output module has prepared to convert.
  - (b) U0x.00.0 ~ U0x.00.3 (%UW0.x.0~%UW0.x.3): It is the flags those display error status of each channel in the analog output module.

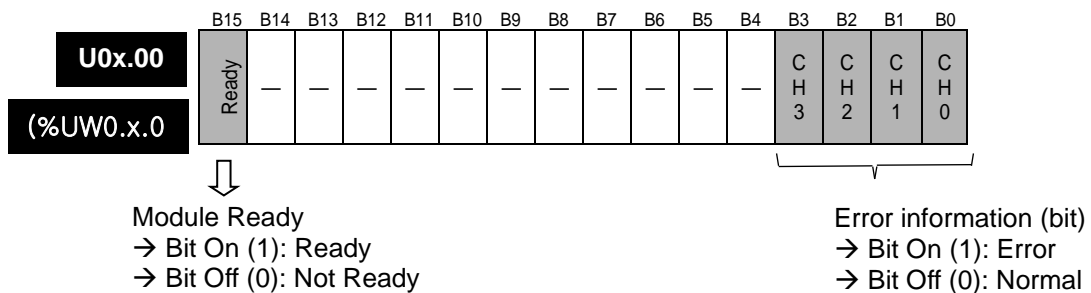

- (2) Channel operation information
- (a) This area is used to display the channel being used.

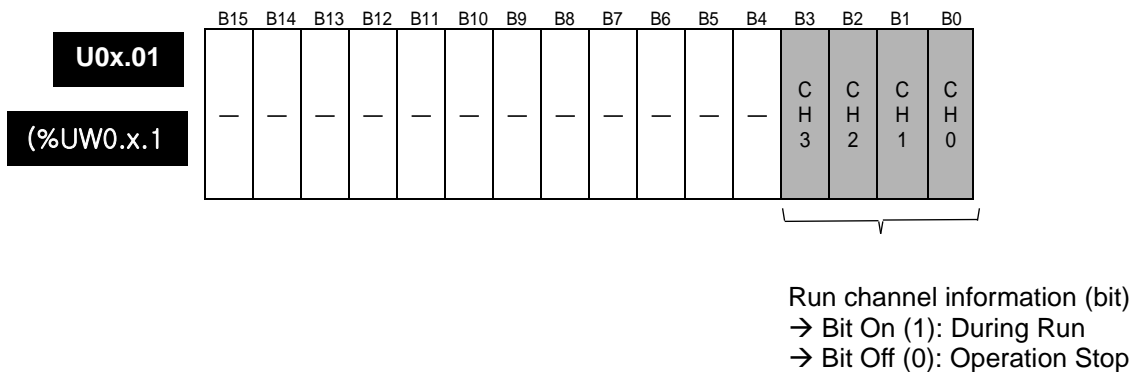

(3) Output setting

- (a) Each channel can be specified enable/disable the analog output.
- (b) If the output is not specified, output of all the channels will be disabled.

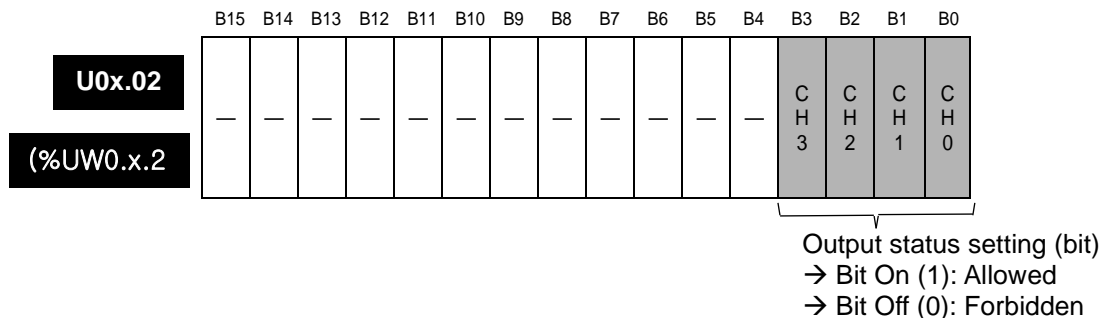

(4) Digital input

- (a) Digital input value can be selected and used within the range of -48~4047, -2048~2047, -12~1011 (381~2018/-24~2023), and -12~1011 based on input type.
- (b) If the digital input value is not specified, it will be set to 0.

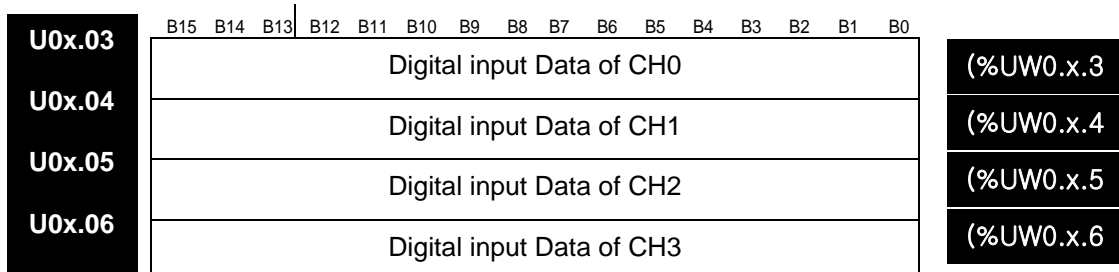

Address ('S', 'H' type)	Address (IEC type)	Details
U0x.03	%UW0.x.3	Digital input value of CH0
U0x.04	%UW0.x.4	Digital input value of CH1
U0x.05	%UW0.x.5	Digital input value of CH2
U0x.06	%UW0.x.6	Digital input value of CH3

## 3.12.2 Setting area of operation parameters

## XBF-DV04A

Address (Dec)	Description	Details	Remarks
0	Set up the run channel	Bit On(1): Run Bit Off(0): Stop	Read/Write available
1	Set up the output voltage range	Bit (00): 0 ~ 10V	
2	Set up the input data type	Bit (00): 0 ~ 4000 Bit (01): -2000 ~ 2000 Bit (10): 0 ~ 1000 Bit (11): 0 ~ 1000	
3	Set up the output type of CH0	0: outputs the previous value 1: outputs the min. value of output range 2: outputs the mid. value of output range 3: outputs the max. value of output range	
4	Set up the output type of CH1		
5	Set up the output type of CH2		
6	Set up the output type of CH3		
11	CH0 setting error	Error code	Read available
12	CH1 setting error		
13	CH2 setting error		
14	CH3 setting error		

## XBF-DC04A

Address (Dec)	Description	Details	Remarks
0	Set up the run channel	Bit On(1): Run Bit Off(0): Stop	Read/Write available
1	Set up the output voltage range	Bit (00): 4 ~ 20mA Bit (01): 0 ~ 20mA	
2	Set up the input data type	Bit (00): 0 ~ 4000 Bit (01): -2000 ~ 2000 Bit (10): 400 ~ 2000/0 ~ 2000 Bit (11): 0 ~ 1000	
3	Set up the output type of CH0	0: outputs the previous value 1: outputs the min. value of output range 2: outputs the mid. value of output range 3: outputs the max. value of output range	
4	Set up the output type of CH1		
5	Set up the output type of CH2		
6	Set up the output type of CH3		
11	CH0 setting error	Error code	Read available
12	CH1 setting error		
13	CH2 setting error		
14	CH3 setting error		

XBF-DC04B

Address (Dec)	Description	Details	Remarks
0	Set up the run channel	Bit On(1): Run Bit Off(0): Stop	Read/Write available
1	Set up the output voltage range	Bit (00): 4 ~ 20mA Bit (01): 0 ~ 20mA	
2	Set up the input data type	Bit (00): 0 ~ 4000 Bit (01): -2000 ~ 2000 Bit (10): 0 ~ 1200 Bit (11): 0 ~ 1000	
3	Set up the output type of CH0	0: outputs the previous value 1: outputs the min. value of output range 2: outputs the mid. value of output range 3: outputs the max. value of output range	
4	Set up the output type of CH1		
5	Set up the output type of CH2		
6	Set up the output type of CH3		
11	CH0 setting error	Error code	Read available
12	CH1 setting error		
13	CH2 setting error		
14	CH3 setting error		

(1) Setting up the run channel

If the run channel is not specified, all the channels will be set to Stop.

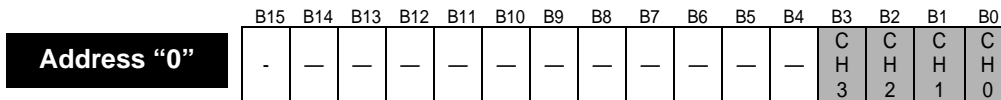

↓

Run channel (bit)  
 → 1: Run  
 → 0: Stop

(2) Setting up the output voltage/current range

The range of analog output voltage is DC 0 ~ 10V and analog output current is DC 4 ~ 20mA, DC 0 ~ 20mA.

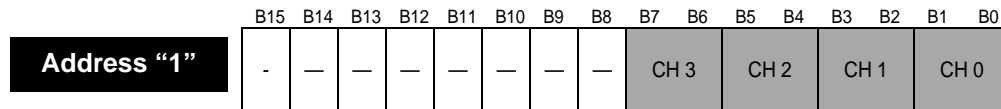

↓

Output range (bit)  
 → 00: 0 ~ 10V(4 ~ 20mA)  
 → 01: 0 ~ 20mA

(3) Setting up the input data type

- (a) Input type can be specified for respective channels.
- (b) If input data type is not specified, all the channels will be set to the range of 0 ~ 4000.

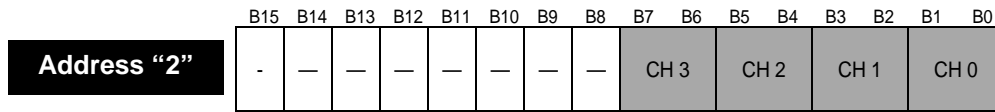

Input data type (bit)  
 → 00: 0 ~ 4000  
 → 01: -2000 ~ 2000  
 → 10: 0 ~ 1000(400 ~ 2000/0 ~ 2000)  
 → 11: 0 ~ 1000

(4) Setting up the output type

- (a) It defines an analog output status when XGB CPU unit is stopped.
- (b) The range is 0 ~3 and used devices are regarded as Words.

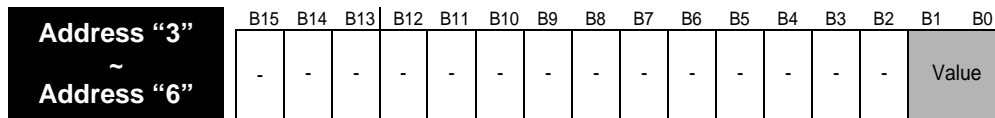

Address	Details
3	Set up the output type of CH0
4	Set up the output type of CH1
5	Set up the output type of CH2
6	Set up the output type of CH3

Input data type (bit)  
 → 00: Previous value  
 → 01: Min. value  
 → 10: Mid. value  
 → 11: Max. value

(5) Error code

It displays error codes of each channel.

Address "11" ~ Address "14"	B15 B14 B13 B12 B11 B10 B9 B8 B7 B6 B5 B4 B3 B2 B1 B0
	Address
	11
	12
	13
	14

Error code (Dec)	Details	LED status
-	Offset/Gain setting error	Flickering 2s intervals
31#	Exceed the range of parameter	Flickering 1s intervals
41#	Exceed the range of digital input	

※ # stands for the channel with error found.

### 3.13 Example Program

#### 3.13.1 Analog output program

(1) Program example using [I/O Parameter Setting].

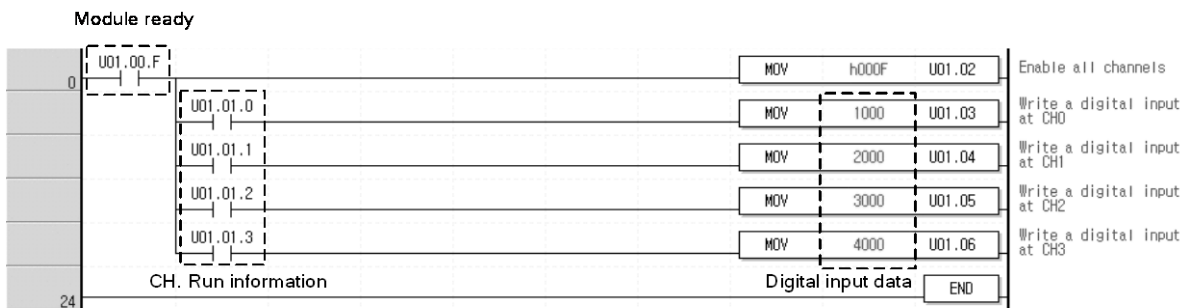
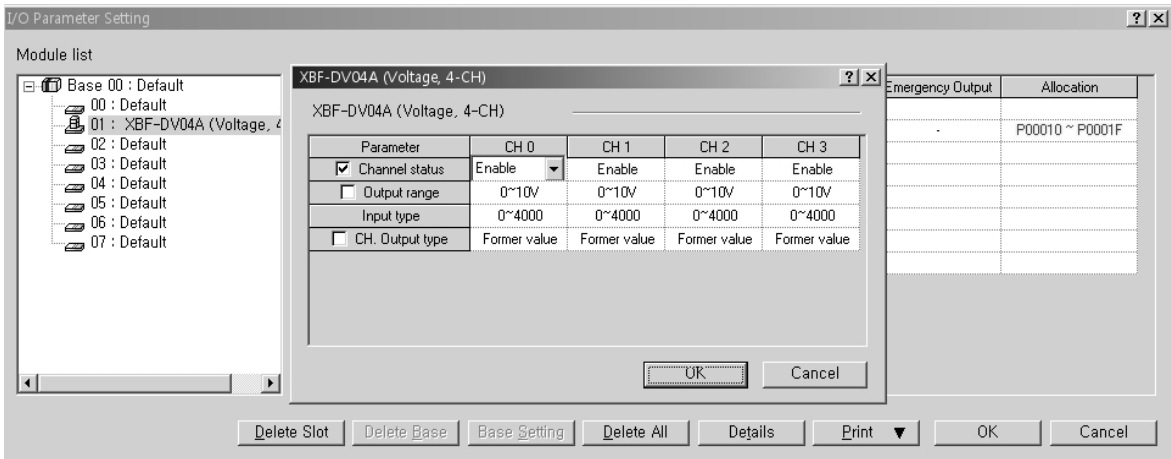
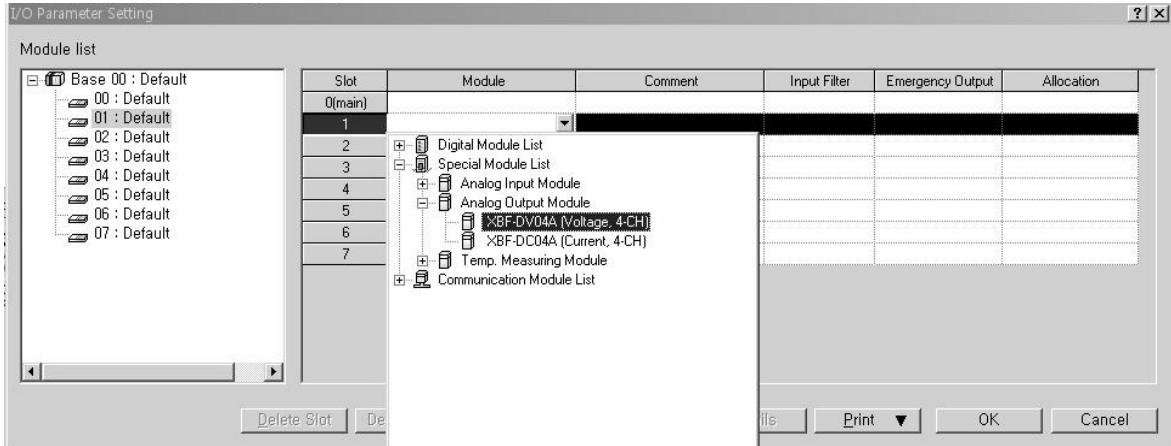

## Chapter 3 Analog Output (XBF-DV04A/DC04A/DC04B)

(2) Program example with PUT/GET instruction.

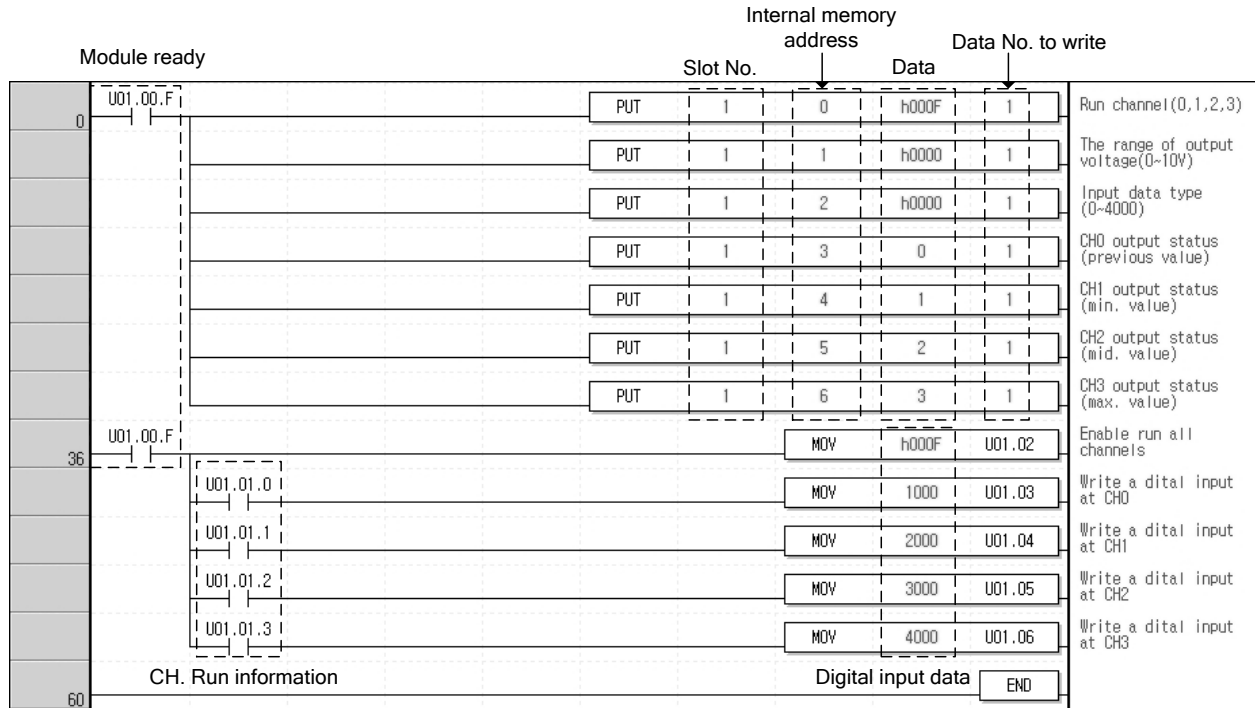

(3) Program example using parameter in case of IEC type

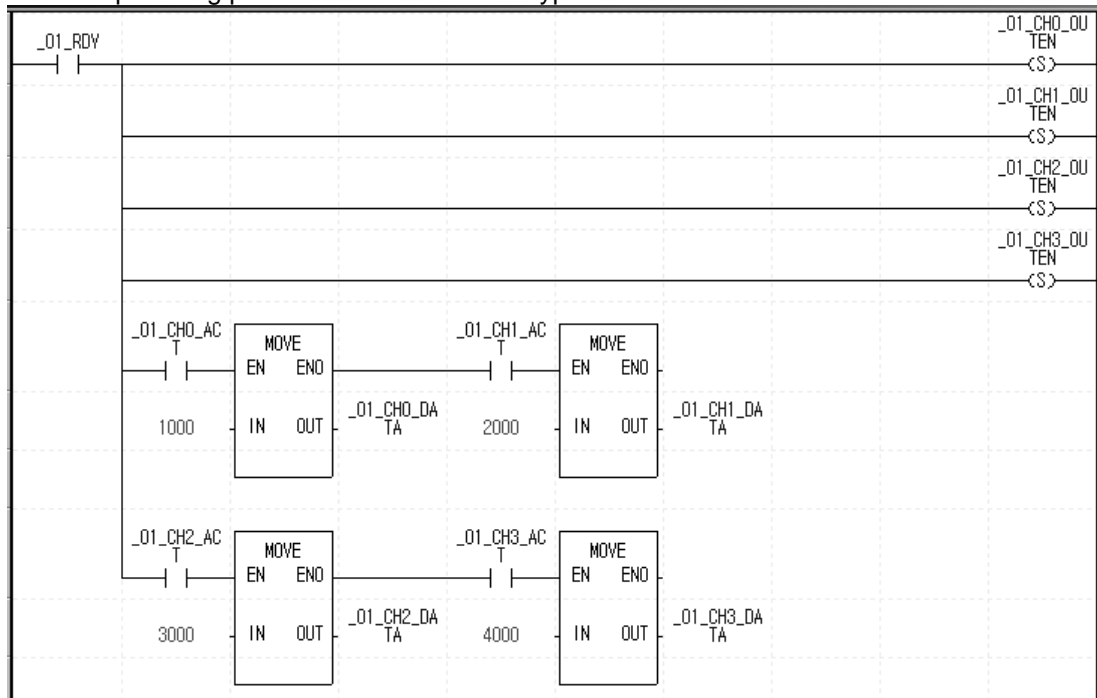



4) Program example using PUT/GET instruction in case of IEC type

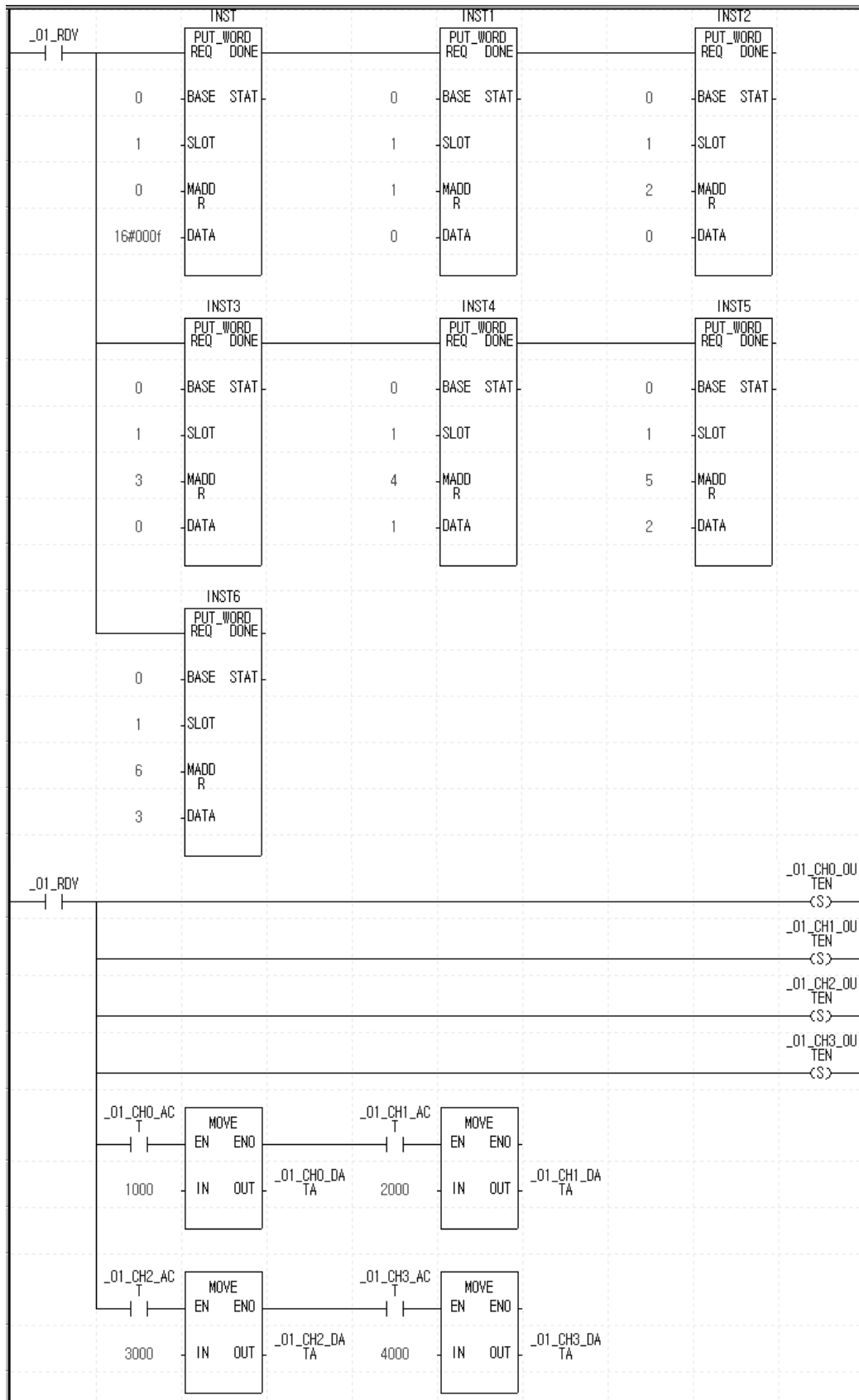

### 3.14 Troubleshooting

#### 3.14.1 RUN LED flickers

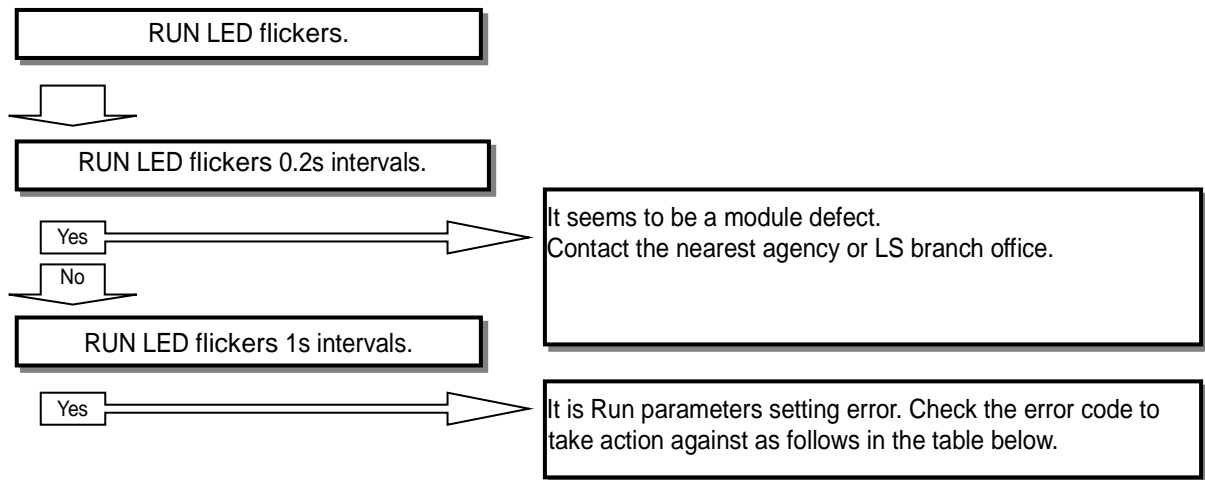

Error Code (Dec.)	Error Details	Action
31#	Parameter range excess error	Adjust parameter setting range
41#	Digital input value range excess error	Adjust digital input value range

※ # indicates channel number.

### 3.14.2 RUN LED is off

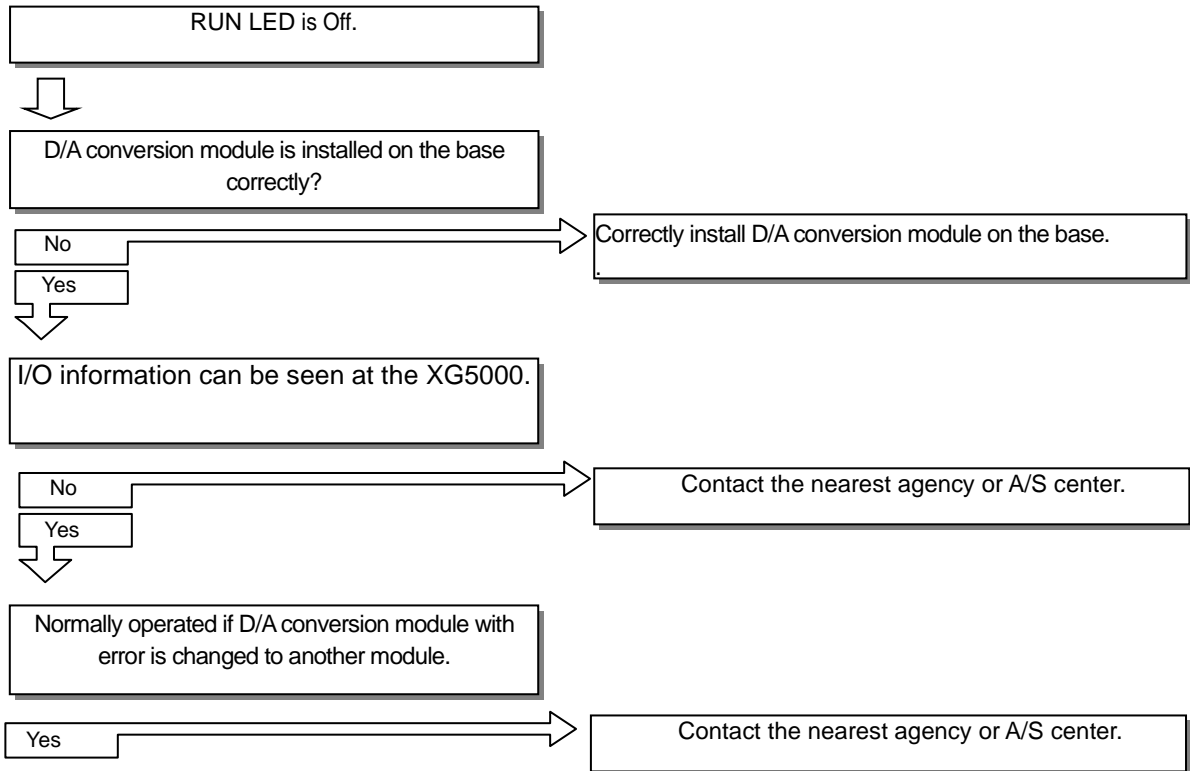

3.14.3 Analog output value is not normal.

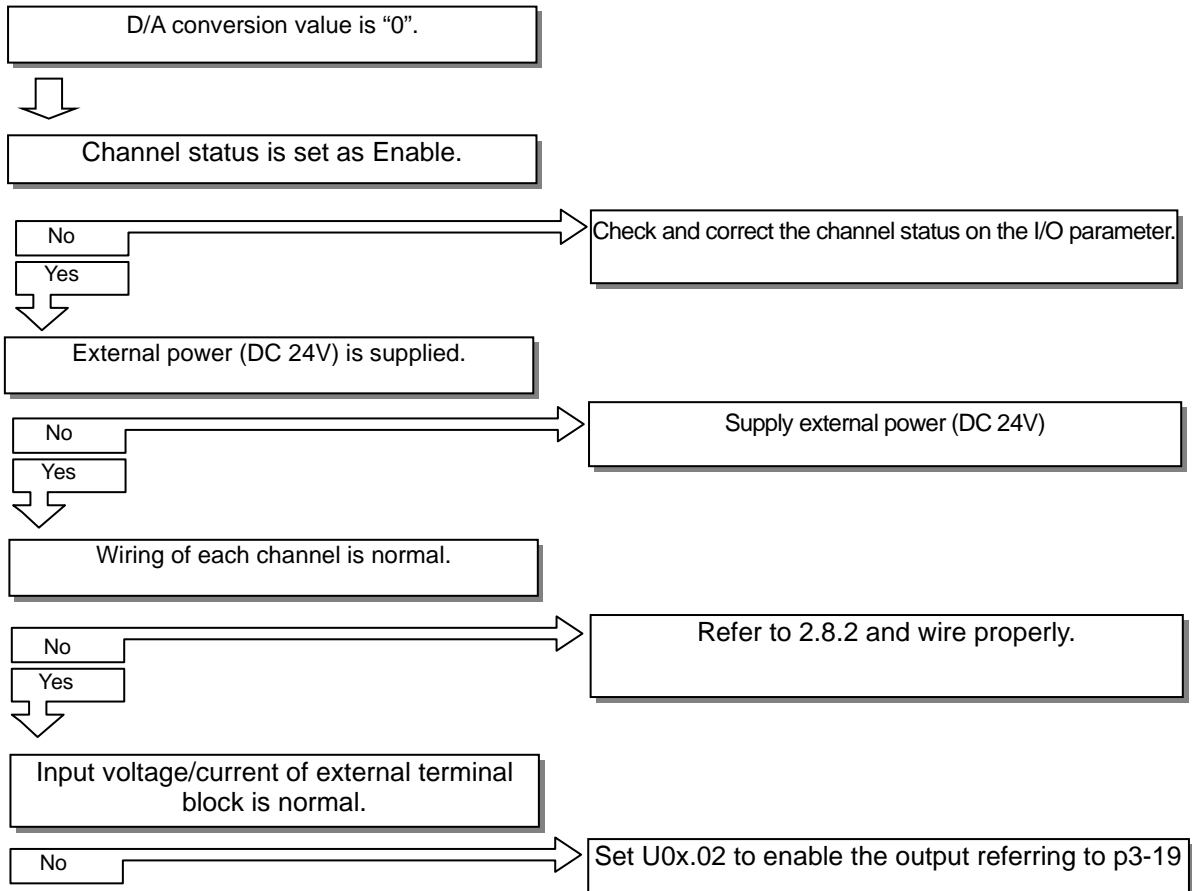

### 3.14.4 Status check of D/A conversion module through XG5000 system monitor

Module type, module information, O/S version and module status of D/A conversion module can be checked through XG5000 system monitoring function.

#### (1) Execution sequence

Two routes are available for the execution.

(a) [Monitor] -> [System Monitoring] -> And on the module screen, click the right mouse button to display [Module Information].

(b) [Monitor] -> [System Monitoring] -> And Double-click the module screen.

#### (2) Module information

(a) Module type: shows the information of the module presently installed.

(b) Module information: shows the O/S version information of A/D conversion module.

(c) O/S version: shows the O/S prepared date of A/D conversion module.

(d) Module status: shows the present error code. (Refer to 3.23 for detailed error codes)

# Chapter 4 RTD Input Module

## 4.1 Setting Sequence before Operation

Before using the RTD input module, follow steps below.

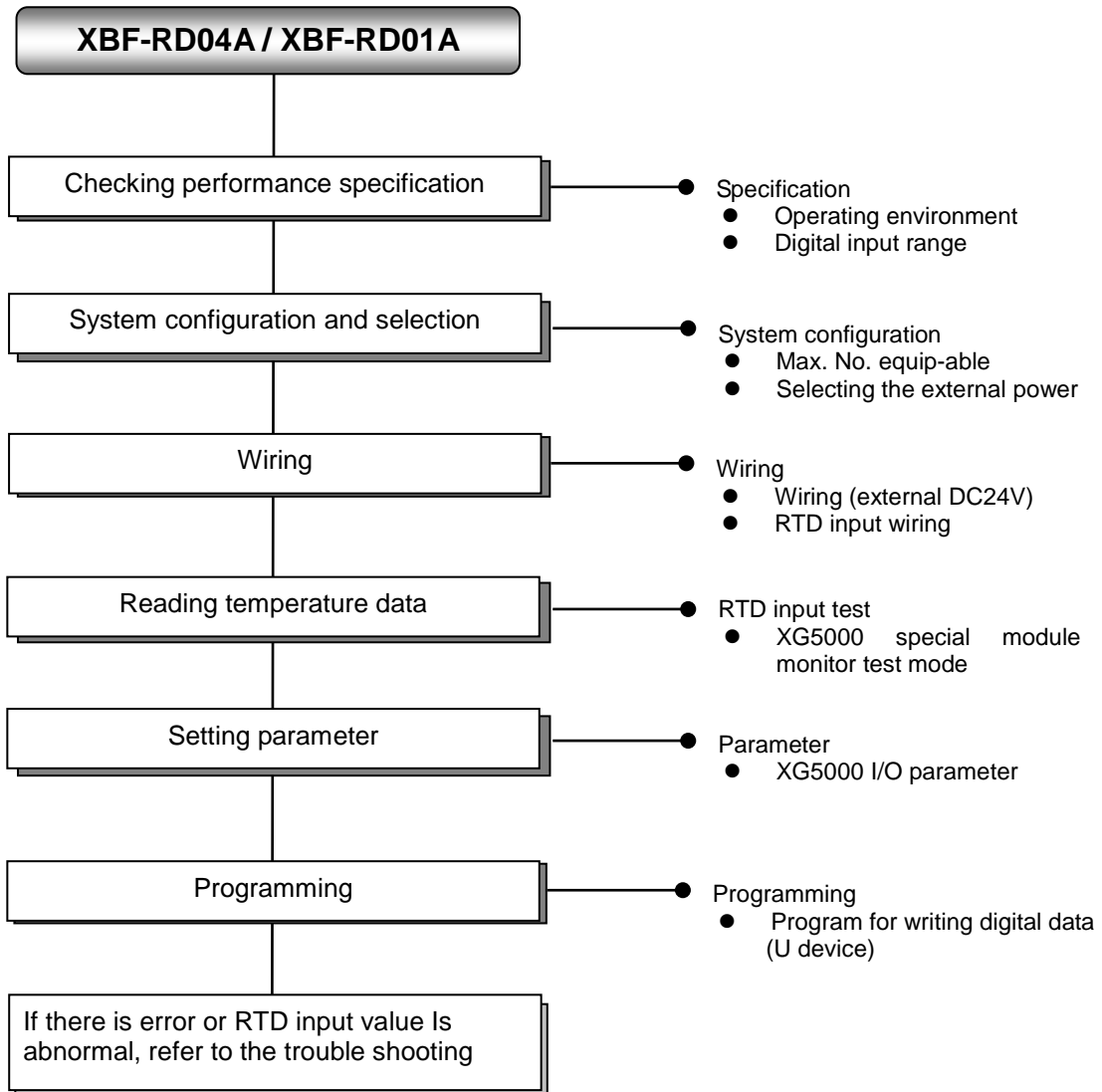

## 4.2 Specification

### 4.2.1 General Specifications

Here describes general specifications of RTD input module.

No.	Item	Specifications	Related specifications			
1	Ambient temperature	0°C ~ +55°C	-			
2	Storage temperature	-25°C ~ +70°C	-			
3	Ambient humidity	5 ~ 95%RH (Non-condensing)	-			
4	Storage humidity	5 ~ 95%RH (Non-condensing)	-			
5	Vibration resistance	Occasional vibration			-	IEC61131-2
		Frequency	Acceleration	Amplitude	How many times	
		5 ≤ f < 8.4 Hz	-	3.5 mm	10 times each directions (X, Y and Z)	
		8.4 ≤ f ≤ 150 Hz	9.8 m/s <sup>2</sup> (1G)	-		
		For continuous vibration				
		Frequency	Acceleration	Amplitude	10 times each directions (X, Y and Z)	
		5 ≤ f < 8.4 Hz	-	1.75 mm		
8.4 ≤ f ≤ 150 Hz	4.9 m/s <sup>2</sup> (0.5G)	-				
6	Shock resistance	<ul style="list-style-type: none"> <li>• Peak acceleration: 147 m/s<sup>2</sup>(15G)</li> <li>• Duration: 11ms</li> <li>• Half-sine, 3 times each direction per each axis</li> </ul>	IEC61131-2			
7	Noise resistance	Square wave Impulse noise	AC: ± 1,500V DC: ± 900V	LSIS standard		
		Electrostatic discharge	Voltage : 4kV (contact discharging)	IEC 61131-2, IEC 61000-4-2		
		Radiated electromagnetic field noise	80 ~ 1,000 MHz, 10V/m	IEC 61131-2, IEC 61000-4-3		
		Fast transient /bust noise	Segment Voltage	Power supply module 2kV	Digital/analog input/output communication interface 1kV	IEC 61131-2, IEC 61000-4-4
8	Environment	Free from corrosive gasses and excessive dust	-			
9	Altitude	Up to 2,000 ms	-			
10	Pollution degree	Less than equal to 2	-			
11	Cooling	Air-cooling	-			

4.2.2 Performance specifications

Here describes general specifications of RTD input module.

Item		Specifications	
		XBF-RD04A	XBF-RD01A
No. of input channel		4 channels	One channel
Input sensor type	PT100	JIS C1604-1997	
	JPT100	JIS C1604-1981 , KS C1603-1991	
Temperature input range	PT100	-200 ~ 600°C	
	JPT100	-200 ~ 600°C	
Digital output	PT100	-2000 ~ 6000	
	JPT100	-2000 ~ 6000	
	Scaling display	0 ~ 4000	
Accuracy	Normal temp.(25°C)	Within ±0.3%	
	Full temp.(0~55°C)	Within ±0.5%	
Conversion speed		40ms / channel	
Insulation	Channel to Channel	Non-insulation	
	Terminal to PLC Power	Insulation (Photo-Coupler)	
Terminal block		15-point terminal block	
I/O points occupied		Fixed type: 64 points	
Wiring method		3-wire	
Max. number of equipment		7 [When using XBM-Dxxx□ (□:"S", "H", "H2", "HP") type] 7 (when using XB(E)C-DxxxSU type) 10 (when using XB(E)C-DxxxH type or XB(E)C-DxxxU type) Not Available (when using XB(E)C-DxxxE type)	
Function	Filtering	Digital filter (160 ~ 64000ms)	
	Alarm	Disconnection detection	
Current consumption	Inner DC5V	100mA	
	external DC24V	100mA	
Weight		63g	



### 4.3 Part Names and Functions

Here describes part names and functions.

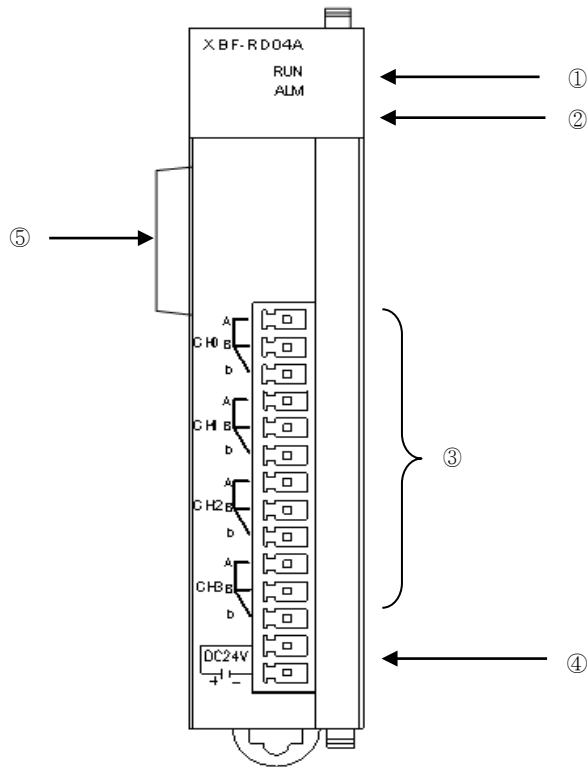

No.	Name	Descriptions
①	RUN LED	<ul style="list-style-type: none"> <li>▶ Displays the hardware operation status of XBF-RD04A</li> <li>On: Normal</li> <li>Flickering: Error (0.2s intervals)</li> <li>Off: power disconnected, hardware error</li> </ul>
②	ALM LED	<ul style="list-style-type: none"> <li>▶ Displays the disconnection status of XBF-RD04A (Alarm indication LED)</li> <li>Flickering: Disconnection is detected (1s intervals)</li> <li>Off: normal operation</li> </ul>
③	Terminal block	<ul style="list-style-type: none"> <li>▶ Terminal block for connecting external RTD temperature sensor</li> </ul>
④	External power supply terminal	<ul style="list-style-type: none"> <li>▶ Terminal for supplying external DC24V</li> </ul>
⑤	Connector for extension	<ul style="list-style-type: none"> <li>▶ Connection connector for connecting extension module</li> </ul>

### 4.4 Temperature Conversion Characteristic

Since RTD sensor has non-linear characteristic, RTD input module linearizes the relationship between input and output in each section.  
 The graph below is an example to describe the linearization process and is different with graph about sensor temperature input.

(1) PT100: JIS1604-1997

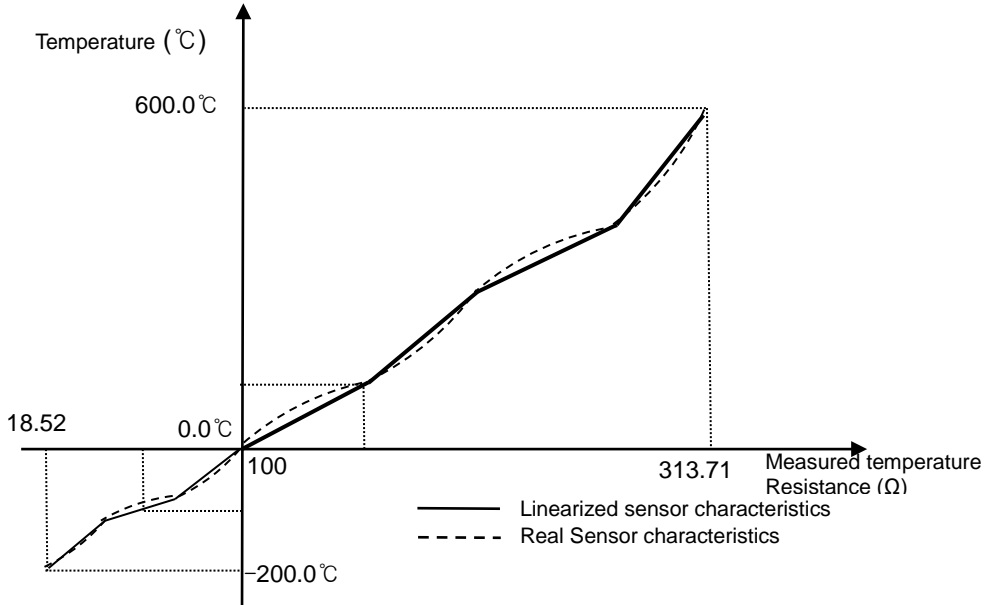

(2) JPT100: JIS C1604-1981, KS C1603-1991

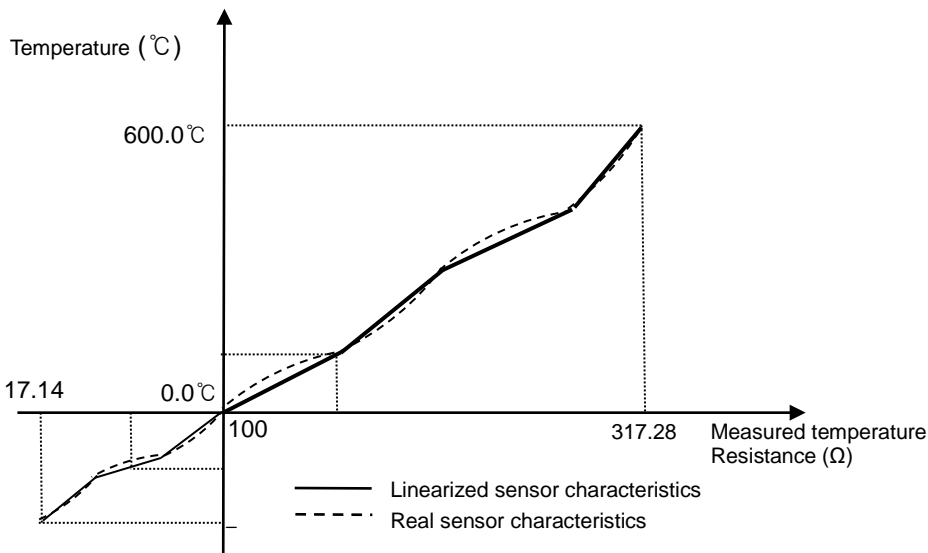

**Remark**

Non-linear characteristics: The resistance-temperature characteristics for RTD sensor are presented with table (JIS C1604-1997). This characteristics table displays resistance value of the sensor to temperature, namely, the change of the resistance value per increment of 1°C. When the temperature is changed by 1°C, the change of resistance is not in constant width but in different width per section, which is called the non-linear characteristics.

## 4.5 Conversion Speed

The conversion speed of XGF-RD4A is 40 ms per channel and each channel is converted sequentially, that is, one channel is converted and then the next channel is converted.

(Run/stop can be specified independently for each channel.)

The conversion speed includes the time to convert input temperature (resistance value) to digital value and to save the converted digital data into the internal memory.

∴ Processing time = 40ms X Number of the using channels

[Example] 3 channels are used: Processing time = 40ms X 3 = 120ms

## 4.6 Accuracy

The accuracy of RTD module is described below.

- When the ambient temperature is  $25 \pm 5^\circ\text{C}$ : within  $\pm 0.3\%$  of available input range
- When the ambient temperature is 0 to  $55^\circ\text{C}$ : within  $\pm 0.5\%$  of available input range

Example) PT100 is used and the ambient temperature is normal.

To measure  $100^\circ\text{C}$ , the conversion data output range:

$100^\circ\text{C} - [ \{ 600 - (-200) \} \times 0.3 \% ] \sim 100^\circ\text{C} + [ \{ 600 - (-200) \} \times 0.3 \% ]$

Namely,  $97.6 \sim 102.4 [^\circ\text{C}]$

## 4.7 Temperature Display

(1) The input temperature is converted to digital value down to the one decimal place.

Ex.) If the detected temperature is  $123.4^\circ\text{C}$ , its converted value to be saved to the internal memory will be 1234.

(2) Temperature can be converted to Celsius or Fahrenheit scale temperature value as desired.

Ex) If Pt100 sensor is used, the temperature of  $100.0^\circ\text{C}$  can be converted to 2120 when Fahrenheit scale is used.

- Conversion  $^\circ\text{C}$  to  $^\circ\text{F}$ ,  $F = \frac{9}{5}C + 32$

- Conversion  $^\circ\text{F}$  to  $^\circ\text{C}$ ,  $C = \frac{5}{9}(F - 32)$

(3) Maximum temperature input range is higher/lower within  $10^\circ\text{C}$  than regular temperature input range. However, the precision will not be guaranteed for any temperature out of regular temperature input range.

Maximum temperature input ranges of sensor are as follows;

- PT100 :  $-210.0 \sim 610.0^\circ\text{C}$
- JPT100 :  $-210.0 \sim 610.0^\circ\text{C}$

## 4.8 Scaling Function

It is used to scale and output the range specified by the user other than temperature range.

- Scaling expression = 
$$\frac{(\text{Temperature} \times 10 + 2000)}{2}$$

Ex.) When scaling is allowed and sensor input is 200°C with PT100 sensor, scaling value is as follows.

$$\text{Scaling value} = \frac{(200 \times 10 + 2000)}{2} = 2000$$

The figure below displays the relation between temperature input and scaling value.

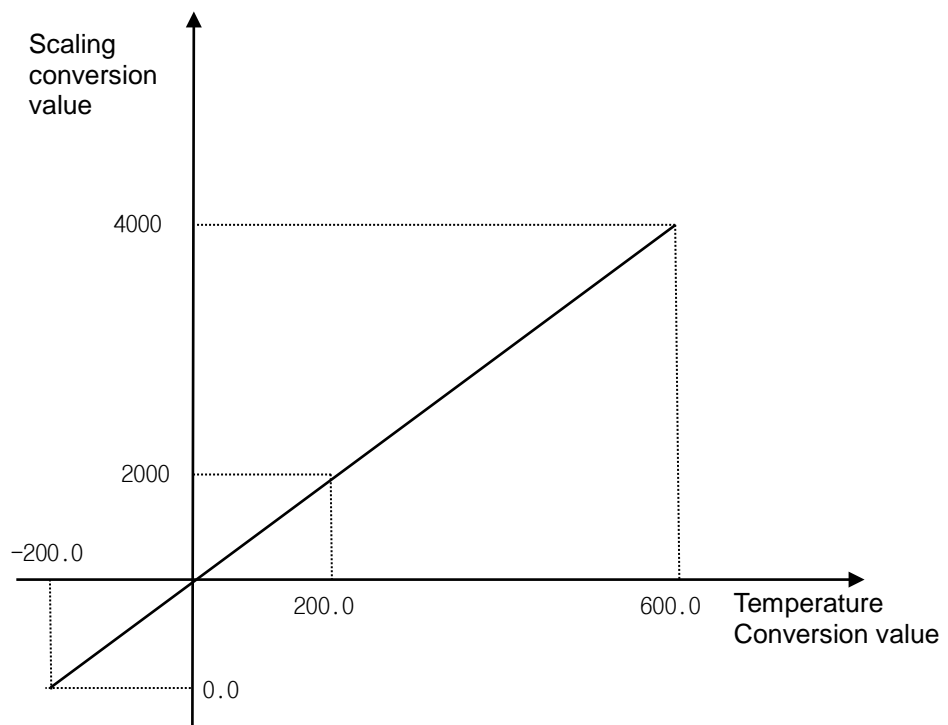

### 4.9 Disconnection Detection Function

- (1) As a module used to measure the temperature with the RTD temperature sensor directly connected, it detects and displays disconnection of the sensor connected. If any disconnection occurs in the sensor used and extended lead wire, LED (ALM) will flicker in a cycle of 1 second and produce an error code.
- (2) Disconnection can be detected per channel, however, only for the channel specified to run. LED (ALM) is used in common for all the channels. It will flicker if one or more channels are disconnected.
- (3) The figure below shows the temperature sensor's appearance of the 3-wired RTD. (The appearance depends on sensor type)

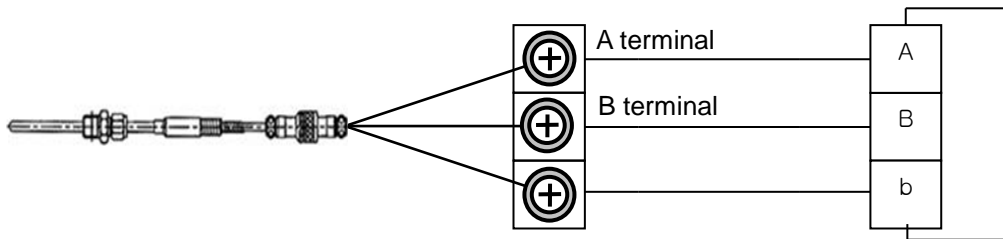

- \* A disconnection: if disconnected between terminal A and terminal board of the module in the sensor figure.
- \* B disconnection: if disconnected between terminal B (two for 3-wired sensor) and terminal board of the module in the sensor figure, or if A and B lines are all disconnected.

- (4) The basic connection between RTD module and RTD Sensor is based on 3-wired RTD sensor. If 2-wired or 4-wired sensor is used, the connection between the sensor and the module shall be kept as 3-wired. Disconnection will be detected on the basis of 3-wired wiring.
- (5) In case of disconnection, status of ALD LED and operation of disconnection flag are as follows.
  - For disconnection flag, refer to 12.3.14 internal memory.

Connection status	Channel status	ALM status	LED	Disconnection flag
Normal	Run	Off		Off
	Stop	Off		Off
A line disconnected or B line disconnected	Run	Flicker (1s)		On
	Stop	Off		Off
Any sensor is not connected	Run	Flicker (1s)		On
	Stop	Off		Off

## 4.10 Wiring

- 3 types of sensor-connecting methods are available (2, 3 and 4-wired).
- The standard wiring method for XGF-RD4A module is 3-wired wiring.
- Use an identical type of wire (thickness, length, etc.) for each 3 wire when extended lead wire is used.
- The resistance of each conductor is to be less than 10Ω. (If larger than this, it will cause an error.)
- Resistance difference of each conductor is to be less than 1Ω. (If larger than this, it will cause an error.)
- Length of wire is to be as short as possible and it is recommended to connect the wire directly to the terminal block of module without connection terminal unit. If a connection terminal is to be used, compensating wire shall be connected as shown below.

### 4.10.1 If 2-wired sensor is used (connection terminal unit is used)

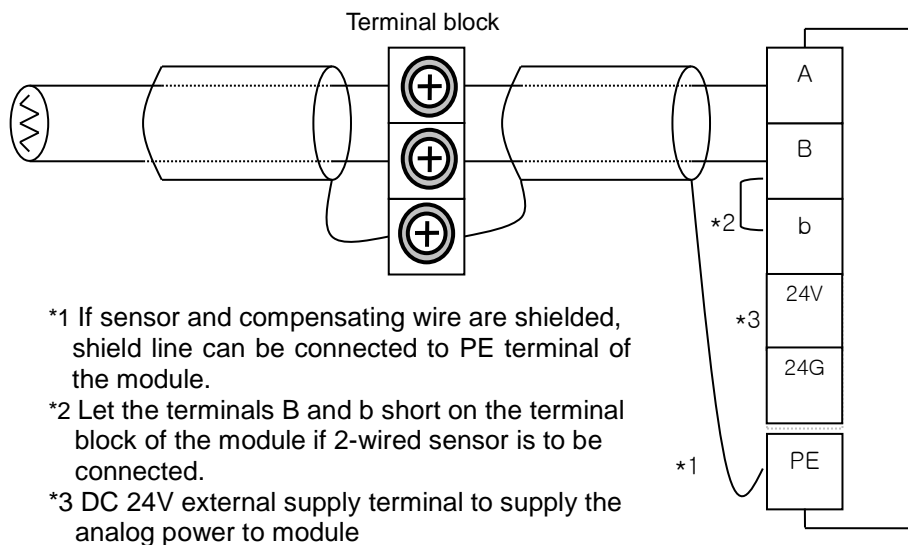

### 4.10.2 If 3-wired sensor is used (connection terminal unit is used)

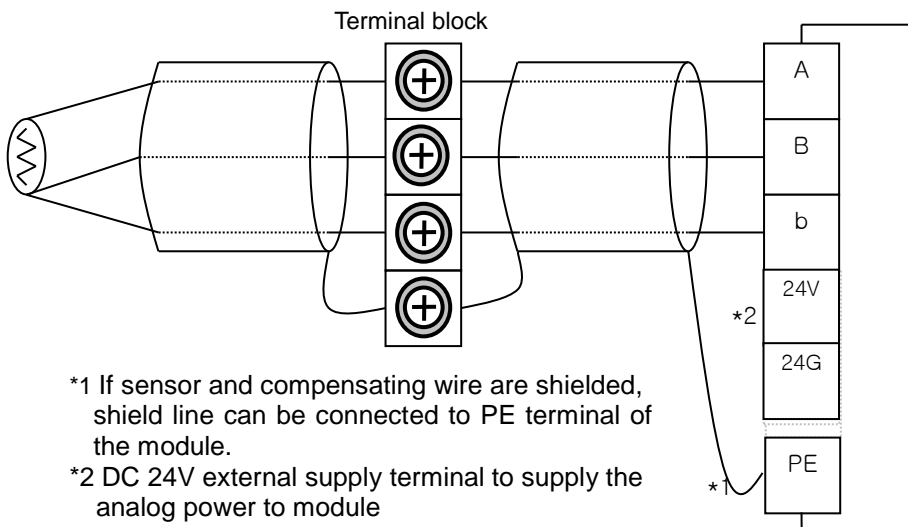

## 4.10.3 If 4-wired sensor is used (connection terminal unit is used)

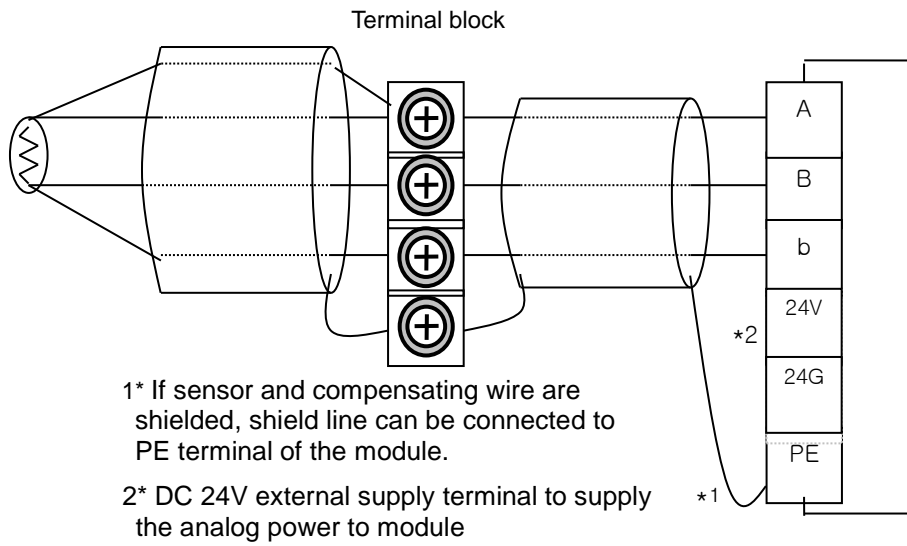

### 4.11 Filtering Function

Based on the filter value (time-constant) which defines the temperature-converted value of the specified channel, it performs and outputs calculation as below.

$$\text{Filtered temperature} = \frac{(\text{Previously filtered temp.} \times \text{Filter value}_{ms}) + (\text{Presently input temp.} \times 40_{ms} \times \text{Channels used})}{\text{Filter value}_{ms} + (40_{ms} \times \text{Channels used})}$$

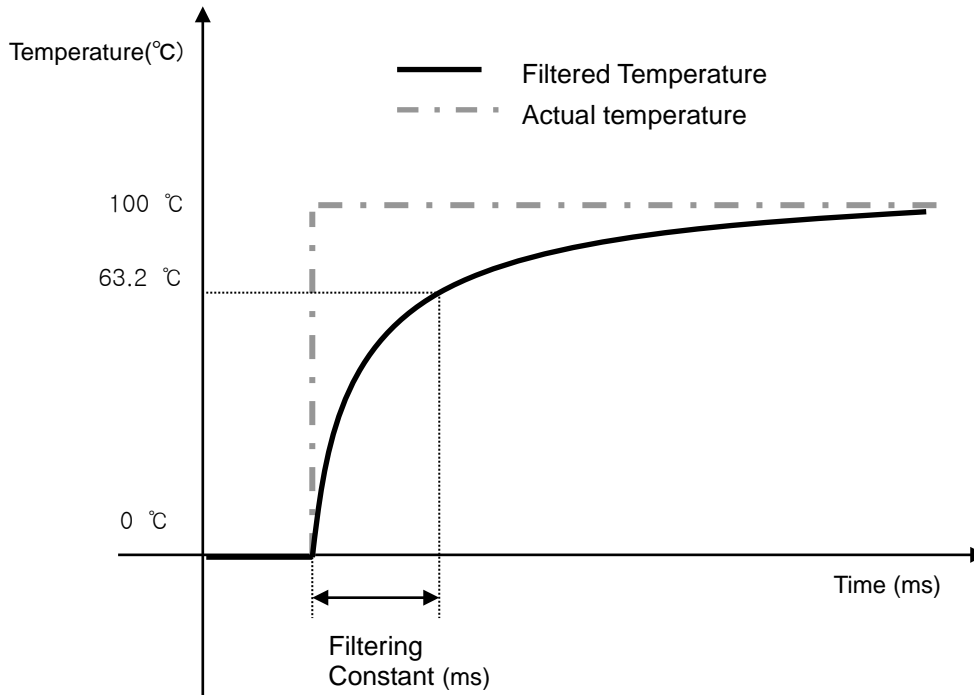

- Filtering constant setting range = 160 ~ 64000 [ms]



## 4.12 Operation Parameter Setting

Operation parameters of RTD module can be specified through [I/O parameters] of XG5000.

### 4.12.1 Setting items

For the user's convenience, XG5000 provides GUI (Graphical User Interface) for parameters setting of RTD module. Setting items available through [I/O parameters] of the XG5000 project window are described below.

Item	Details
[I/O Parameter]	<p>(1) Specify the following setting items necessary for the module operation.</p> <ul style="list-style-type: none"> <li>- Channel Run/Stop</li> <li>- Sensor type</li> <li>- Filter setting</li> <li>- Scaling setting</li> </ul> <p>(2) The data specified by user through S/W package will be saved on the flash memory of RTD module when [I/O Parameters] are downloaded.</p>

### 4.12.2 How to use [I/O Parameter]

- (1) Run XG5000 to create a project. (Refer to XG5000 programming manual for details on how to create the project)
- (2) Double-click [I/O Parameter] on the project window.

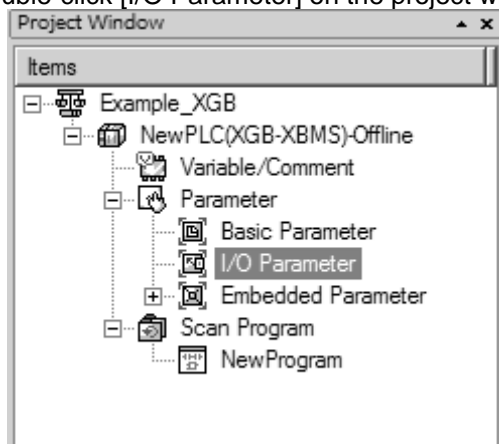

- (3) If [I/O Parameter Setting] screen appears, click Module part at relevant slot and select relevant module.
- (4) On the 'I/O parameters setting' screen, find and click the slot of the base where RTD module is installed on.

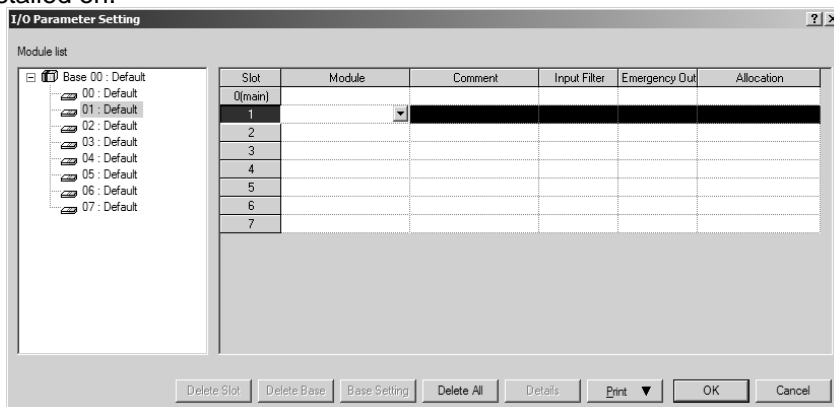

## Chapter 4 RTD Input (XBF-RD04A/RD01A)

- (5) Click the arrow button on the screen to display the screen where an applicable module can be selected. Search for the applicable module to select.

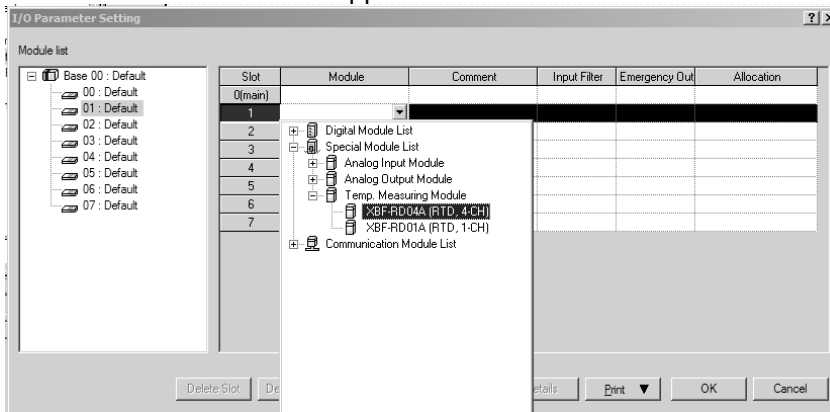

- (6) After the module selected, click [Details] or double-click relevant slot.

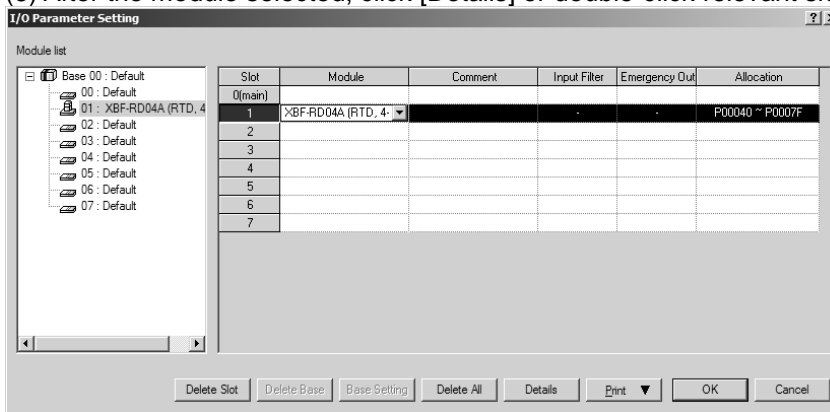

- (7) A screen will be displayed to specify parameters for respective channels as shown below. Click a desired item to display parameters to set for respective items.

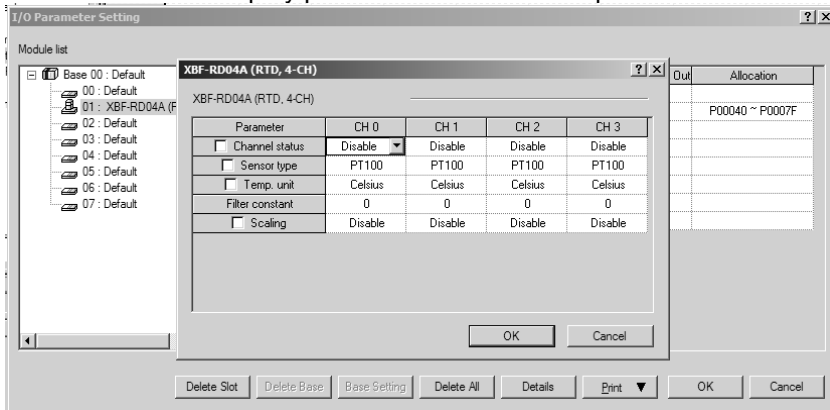

- (8) The initial values of respective items are as follows.

(a) Channel status setting screen

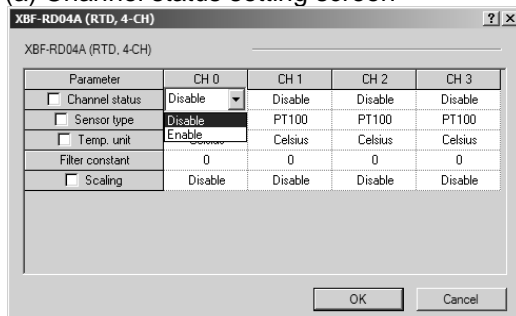

(b) Input sensor type setting screen

Parameter	CH 0	CH 1	CH 2	CH 3
<input type="checkbox"/> Channel status	Disable	Disable	Disable	Disable
<input type="checkbox"/> Sensor type	PT100	PT100	PT100	PT100
<input type="checkbox"/> Temp. unit	Celsius	Celsius	Celsius	Celsius
Filter constant	0	0	0	0
<input type="checkbox"/> Scaling	Disable	Disable	Disable	Disable

(c) Temp. unit setting screen

Parameter	CH 0	CH 1	CH 2	CH 3
<input type="checkbox"/> Channel status	Disable	Disable	Disable	Disable
<input type="checkbox"/> Sensor type	PT100	PT100	PT100	PT100
<input type="checkbox"/> Temp. unit	Celsius	Celsius	Celsius	Celsius
Filter constant	0	0	0	0
<input type="checkbox"/> Scaling	Disable	Disable	Disable	Disable

(d) Scaling setting screen

Parameter	CH 0	CH 1	CH 2	CH 3
<input type="checkbox"/> Channel status	Disable	Disable	Disable	Disable
<input type="checkbox"/> Sensor type	PT100	PT100	PT100	PT100
<input type="checkbox"/> Temp. unit	Celsius	Celsius	Celsius	Celsius
Filter constant	0	0	0	0
<input type="checkbox"/> Scaling	Disable	Disable	Disable	Disable

(9) If necessary setting is complete, press OK.

(10) Check the check box on the parameter menu to select and change setting of a channel then the setting value of all the channels will be identical to changed setting value. The figure below shows an example with this function that channel status is changed to 'Enable' of all the channels.

Parameter	CH 0	CH 1	CH 2	CH 3
<input checked="" type="checkbox"/> Channel status	Enable	Enable	Enable	Enable
<input type="checkbox"/> Sensor type	PT100	PT100	PT100	PT100
<input type="checkbox"/> Temp. unit	Celsius	Celsius	Celsius	Celsius
Filter constant	0	0	0	0
<input type="checkbox"/> Scaling	Disable	Disable	Disable	Disable

### 4.13 Special Module Monitoring

Run Special Module Monitoring by selecting [On-Line] -> [Connect] and [Monitor] -> [Special Module Monitoring]. If the status is not [On-Line], [Special Module Monitoring] menu will not be activated.

**Remark**

- 1) If the program is not displayed normally because of insufficient system resource, you may start XG5000 again after close the program and other applications.
- 2) I/O parameters those are specified in the state of [Special Module Monitoring] menu are temporarily set up for the test. They will be disappeared when the [Special Module Monitoring] is finished.
- 3) Testing of [Special Module Monitoring] is the way to test the analog output module. It can test the module without a sequence program.

#### 4.13.1 How to use special module monitoring

(1) Start of [Special Module Monitoring]

Go through [Online] → [Connect] and [Monitor] → [Special module Monitoring] to start. If the status is not online, [Special Module Monitoring] menu will not be activated.

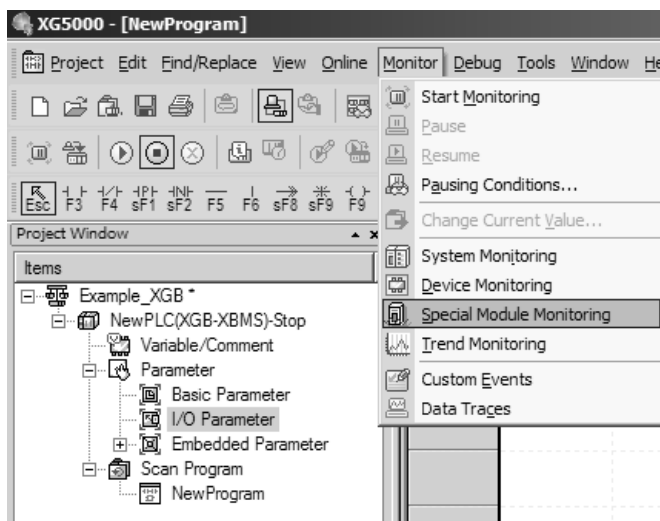

(2) How to use [Special Module Monitoring]

(a) [Special Module List] window will show base/slot information and types of special module by click [Monitor] → [Special Module Monitoring]. In this list box, the modules that are now installed in PLC system will be displayed.

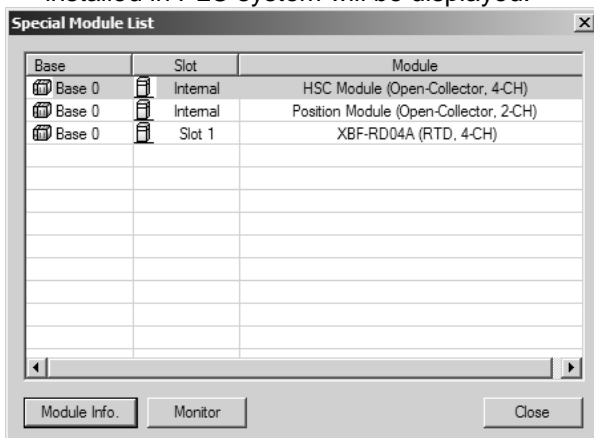

- (b) Select a special module then click [Module Info.] button to display the information as described below.

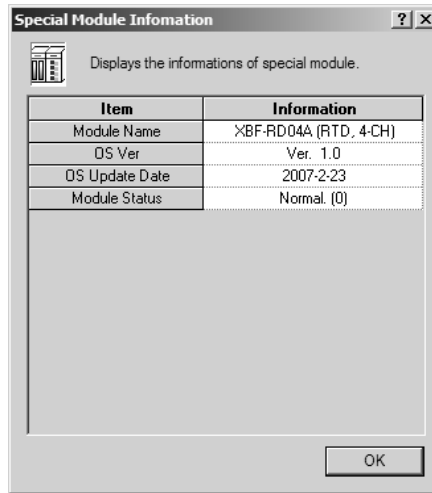

- (c) Select a special module then click [Start Monitoring] button to display the information as described below.

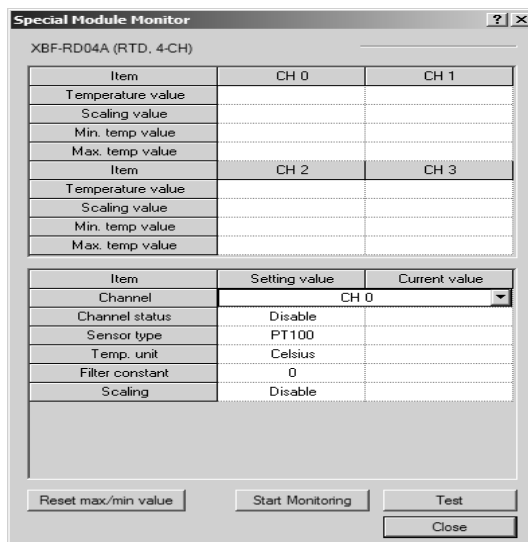

- (d) [Start Monitoring]: [Start Monitoring] button will show you digital input data of the operating channel. The figure below is monitoring screen when all channels are Run status.

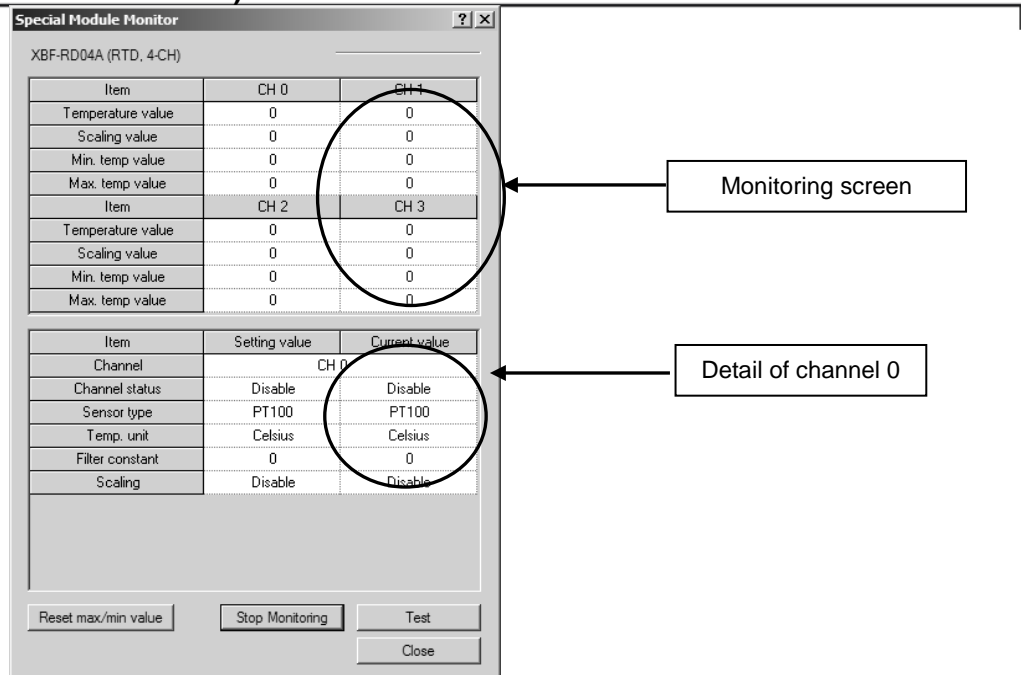

[Start Monitoring] execution screen

- (e) [Test]: [Test] is used to change the parameters of the RTD input module. You can change the parameters when you click the values at the bottom of the screen. It is only available when XGB CPU unit's status is in [Stop].

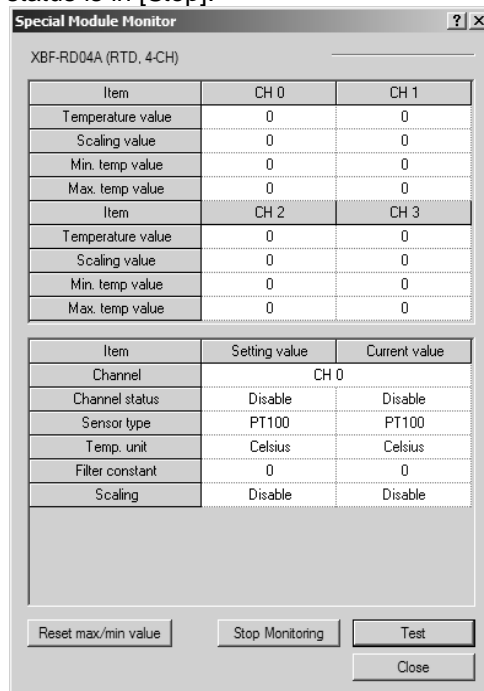

[Test] execution screen

- (g) [Close]: [Close] is used to escape from the monitoring/test screen. When the monitoring/test screen is closed, the max. value, the min. value and the present value will not be saved any more.

**Remark** [Test] function is only available when XGB CPU unit's status is in [Stop]

### 4.14 Register U devices (Special module variable)

Register the variables for each module referring to the special module information that is set in the I/O parameter. The user can modify the variables and comments.

(1) Procedure

(a) Select the special module type in the [I/O Parameter Setting] window.

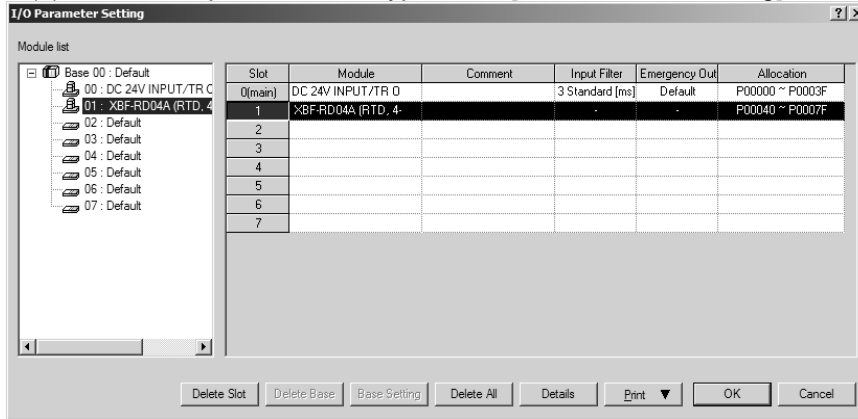

(b) Double click 'Variable/Comment' from the project window.

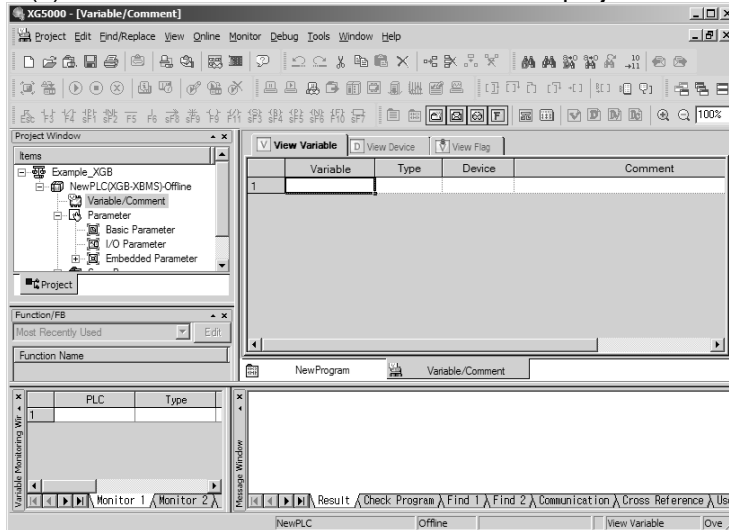

(c) Select [Edit] – [Register U Device].

In case of IEC, select [Edit] – [Register special module variable]

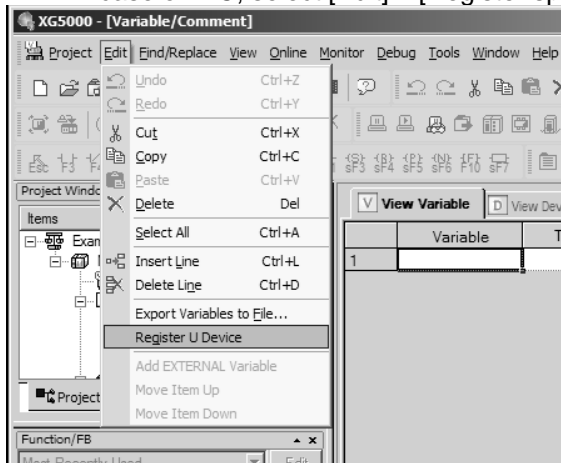

(d) Click 'Yes'.

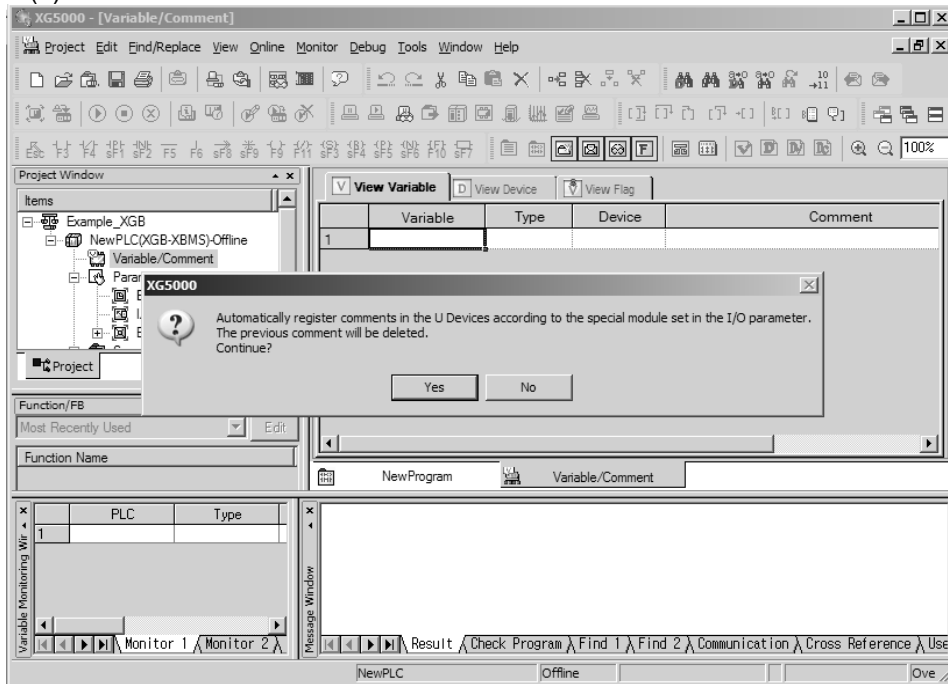

(e) As shown below, the variables are registered.

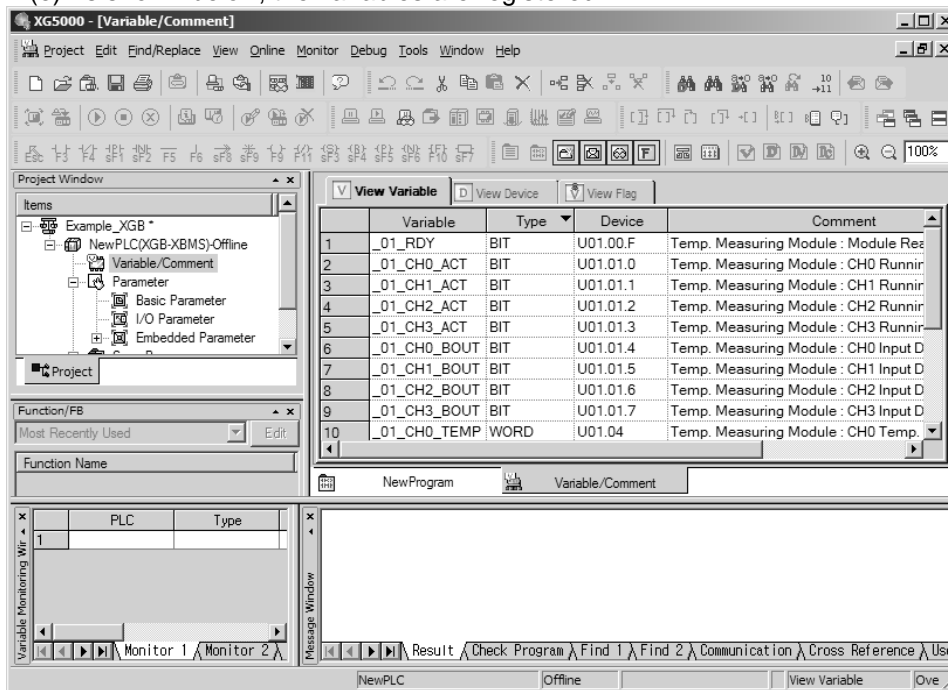

(2) Save variables

- (a) The contents of 'View Variable' can be saved as a text file.
- (b) Select [Edit] -> [Export to File].
- (c) The contents of 'View variable' are saved as a text file.



(3) View variables

(a) The example program of XG5000 is as shown below.

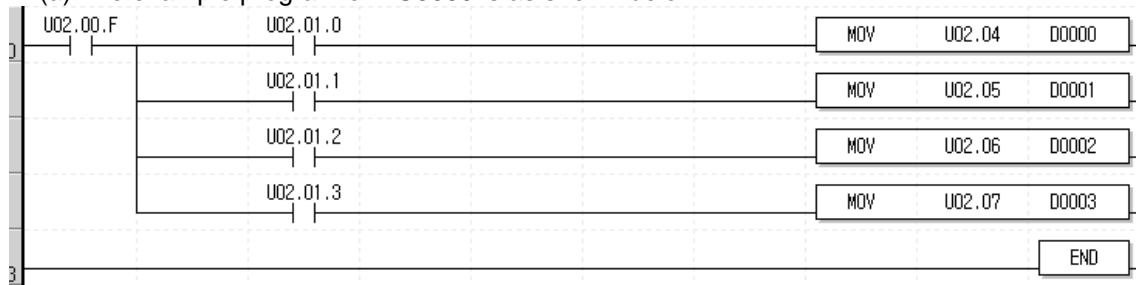

(b) Select [View] -> [Variables]. The devices are changed into variables.

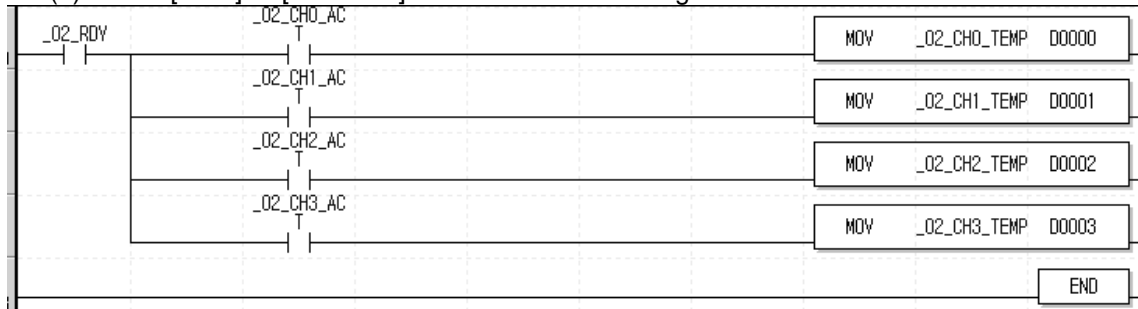

(c) Select [View] -> [Devices/Variables]. Devices and variables are both displayed.

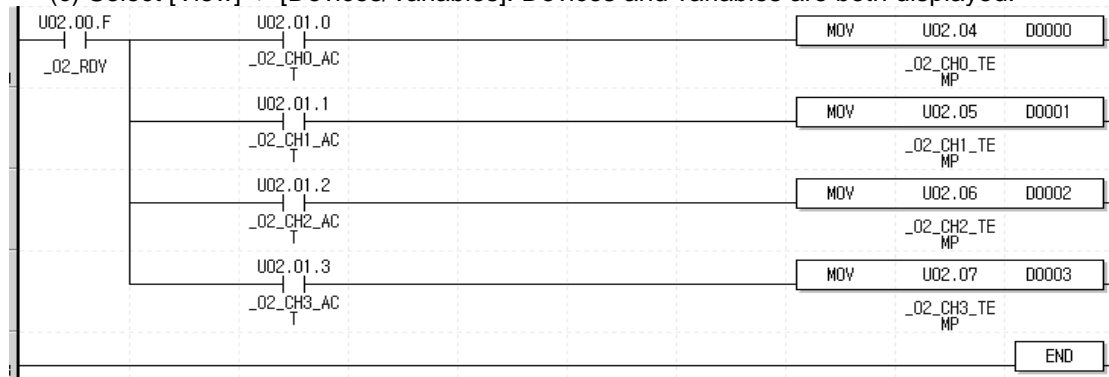

(d) Select [View] -> [Device/Comments]. Devices and comments are both displayed.

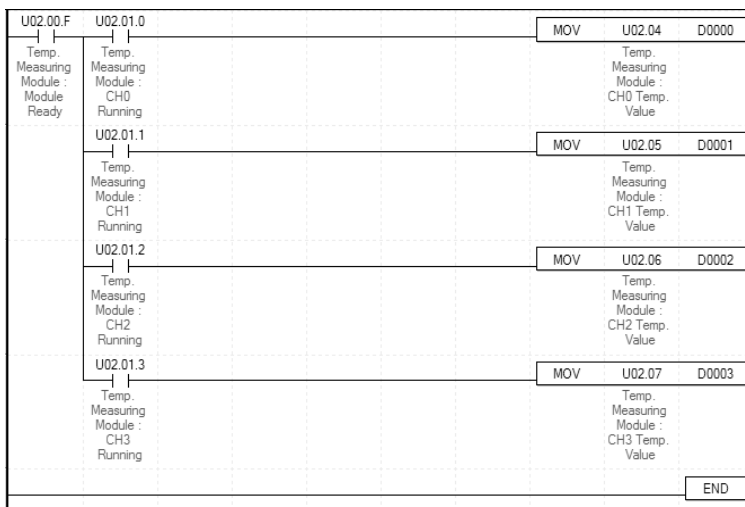

## 4.15 Configuration and Function of Internal Memory

Here describes configuration and function of internal memory.

### 4.15.1 Data I/O area of RTD input module

Data I/O area of RTD input module is as shown below.

Area ('S', 'H' type)	Area (IEC type)	Details	Content	R/W
U0x.00.0 U0x.00.F	%UX0.x.0 %UX0.x.15	Module ERROR flag Module READY flag	0 Bit On(1): module error F(15) Bit On(1): module normal	R
U0x.01.0 U0x.01.1 U0x.01.2 U0x.01.3	%UX0.x.16 %UX0.x.17 %UX0.x.18 %UX0.x.19	CH0 Run flag CH1 Run flag CH2 Run flag CH3 Run flag	Bit On(1): channel run Bit Off(0): channel stop	R
U0x.01.4 U0x.01.5 U0x.01.6 U0x.01.7	%UX0.x.20 %UX0.x.21 %UX0.x.22 %UX0.x.23	CH0 Disconnection flag CH1 Disconnection flag CH2 Disconnection flag CH3 Disconnection flag	Bit On(1): Disconnection Bit Off(0): Normal	R
U0x.04	%UW0.x.4	CH0 digital output value	Temperature value x10	R
U0x.05	%UW0.x.5	CH1 digital output value	–	R
U0x.06	%UW0.x.6	CH2 digital output value	–	R
U0x.07	%UW0.x.7	CH3 digital output value	–	R
U0x.08	%UW0.x.8	CH0 scaling value	0 ~ 4000	R
U0x.09	%UW0.x.9	CH1 scaling value	–	R
U0x.10	%UW0.x.10	CH2 scaling value	–	R
U0x.11	%UW0.x.11	CH3 scaling value	–	R

※ In the device assigned, x stands for the slot no. on which module is installed.

(1) Module ready/channel error information ( ( ) means device name of IEC type)

- (a) U0x.00.F (%UX0.x.15): It will be ON when PLC CPU is powered or reset with A/D conversion ready to process A/D conversion.
- (b) U0x.00.0 ~ U0x.00.3 (%UW0.x.0~%UW0.x.3): It is a flag to display the error status of A/D conversion module.

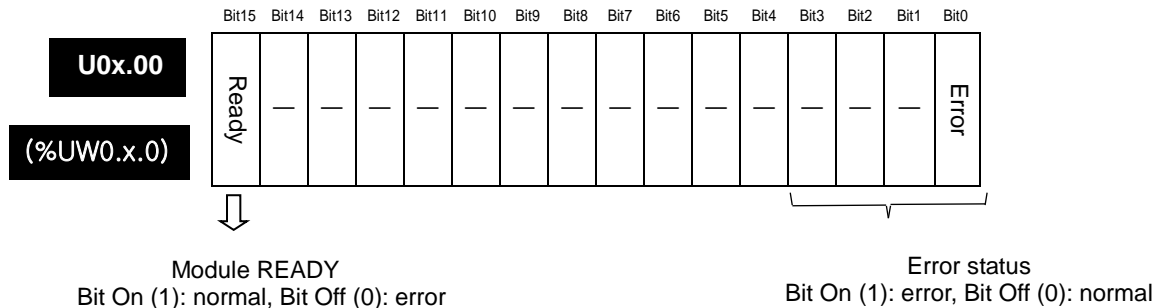

(2) Channel run/stop information

(a) It displays which channel is being used.

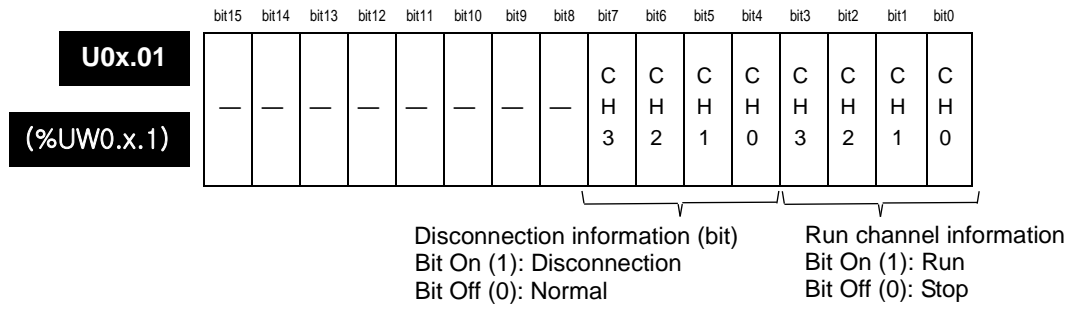

(3) Temperature value

It displays current temperature value. Its form is temperature value ×10.

	bit15	bit14	bit13	bit12	bit11	bit10	bit9	bit8	bit7	bit6	bit5	bit4	bit3	bit2	bit1	bit0	
<b>U0x.04</b>	CH0 temperature conversion value															<b>(%UW0.x.4)</b>	
<b>U0x.05</b>	CH1 temperature conversion value															<b>(%UW0.x.5)</b>	
<b>U0x.06</b>	CH2 temperature conversion value															<b>(%UW0.x.6)</b>	
<b>U0x.07</b>	CH3 temperature conversion value															<b>(%UW0.x.7)</b>	

### 4.15.2 Operation parameter setting area

Operation parameter setting areas of RTD input module are as follows.

Memory address		Details	R/W	Remark
Hex.	Dec.			
0H	0	Channel enable/disable setting	R/W	PUT
1H	1	CH0 sensor type setting	R/W	PUT
2H	2	CH1 sensor type setting	R/W	PUT
3H	3	CH2 sensor type setting	R/W	PUT
4H	4	CH3 sensor type setting	R/W	PUT
5H	5	Temperature display unit setting	R/W	PUT
6H	6	CH0 filter constant setting	R/W	PUT
7H	7	CH1 filter constant setting	R/W	PUT
8H	8	CH2 filter constant setting	R/W	PUT
9H	9	CH3 filter constant setting	R/W	PUT
AH - 11H	10~17	Not used	-	-
12H	18	Scaling setting	R/W	PUT
13H - 43H	19~67	Not used	-	-
44H	68	CH0 disconnection information (code)	R/W	GET
45H	69	CH1 disconnection information (code)	R/W	GET
46H	70	CH2 disconnection information (code)	R/W	GET
47H	71	CH3 disconnection information (code)	R/W	GET

(1) Run channel setting

If Run channel is not specified, all channels will be stop status.

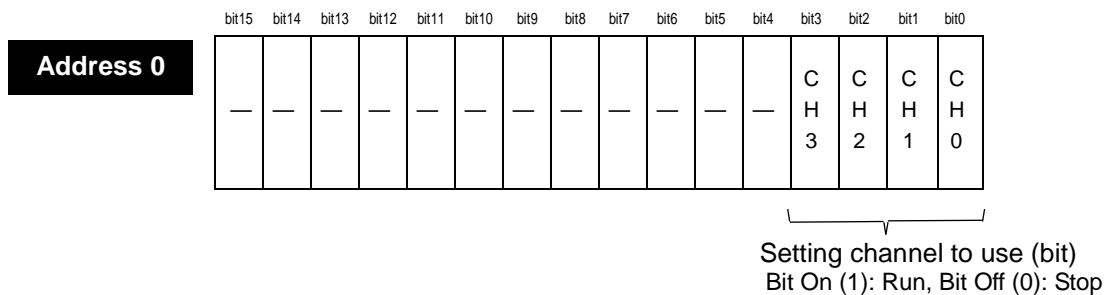

(2) Sensor type setting

If it is not specified manually, all channels will be specified as Pt100.

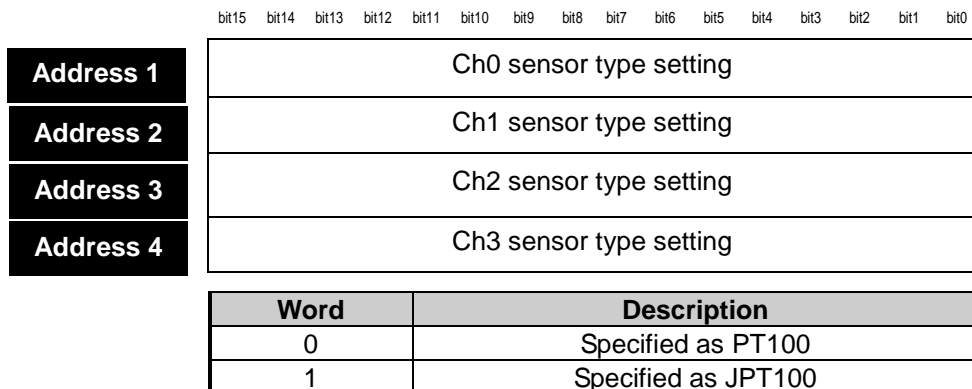

(3) Setting temperature display unit

Unit of temperature conversion value can be specified as Celsius/ Fahrenheit.

<b>Address 5</b>	bit15	bit14	bit13	bit12	bit11	bit10	bit9	bit8	bit7	bit6	bit5	bit4	bit3	bit2	bit1	Bit0
	—	—	—	—	—	—	—	—	—	—	—	—	C H 3	C H 2	C H 1	C H 0

Bit	Description
0	Celsius
1	Fahrenheit

(4) Setting filter constant

If filter constant is not specified or specified as “0”, relevant channel is not filtered.

<b>Address 6</b>	Setting Ch0 filter constant (1~99)
<b>Address 7</b>	Setting Ch1 filter constant (1~99)
<b>Address 8</b>	Setting Ch2 filter constant (1~99)
<b>Address 9</b>	Setting Ch3 filter constant (1~99)

(5) Setting scaling

It specifies whether scaling function is used or not.

<b>Address 10</b>	bit15	bit14	bit13	bit12	bit11	bit10	bit9	bit8	bit7	bit6	bit5	bit4	bit3	bit2	bit1	bit0
	—	—	—	—	—	—	—	—	—	—	—	—	C H 3	C H 2	C H 1	C H 0

Bit	Description
0	Scaling function is not used
1	Scaling function is used

(6) Disconnection information

It outputs disconnection information of each channel.

<b>Address 68</b>	Channel 0 disconnection information (0: normal, 1: sensor A disconnection, 2: sensor B disconnection)
<b>Address 69</b>	Channel 1 disconnection information (0: normal, 1: sensor A disconnection, 2: sensor B disconnection)
<b>Address 70</b>	Channel 2 disconnection information (0: normal, 1: sensor A disconnection, 2: sensor B disconnection)
<b>Address 71</b>	Channel 3 disconnection information (0: normal, 1: sensor A disconnection, 2: sensor B disconnection)

### 4.16 Example Program

- Here describes how to specify the operation condition of RTD input module.
- RTD input module is installed on slot 2.
- Initial setting condition is that with one input, initial setting value is saved in internal memory of module.
- The following program is an example to read temperature value and disconnection information.

(1) Program example using [I/O Parameter Setting]

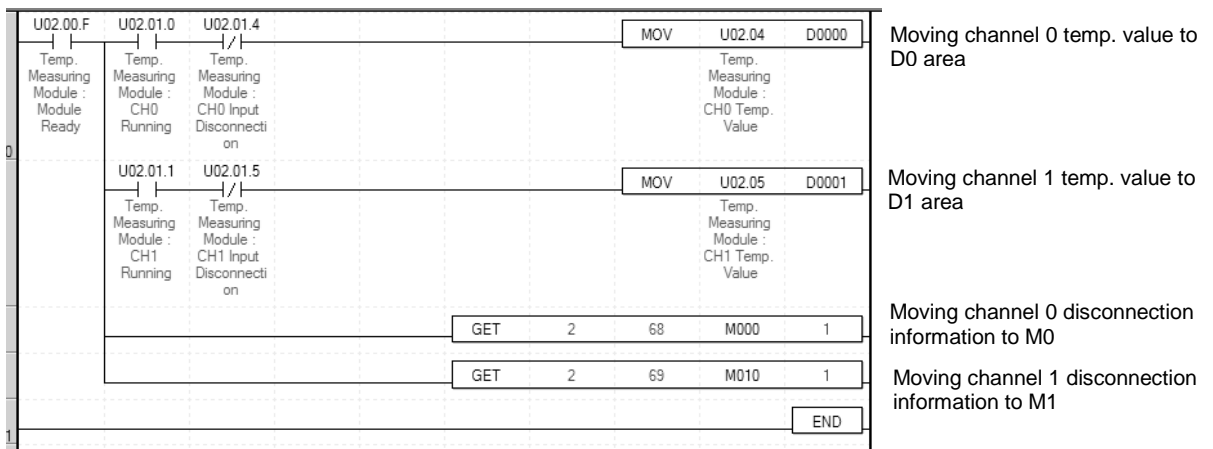
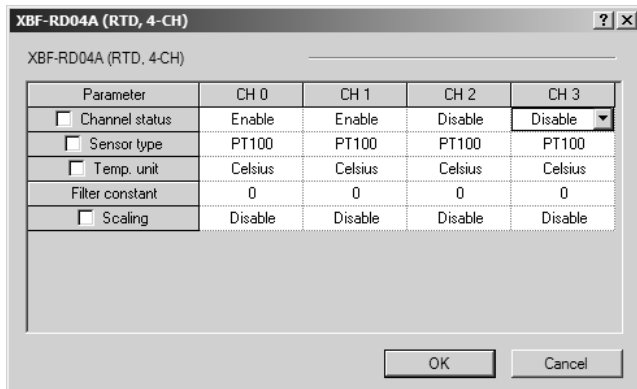
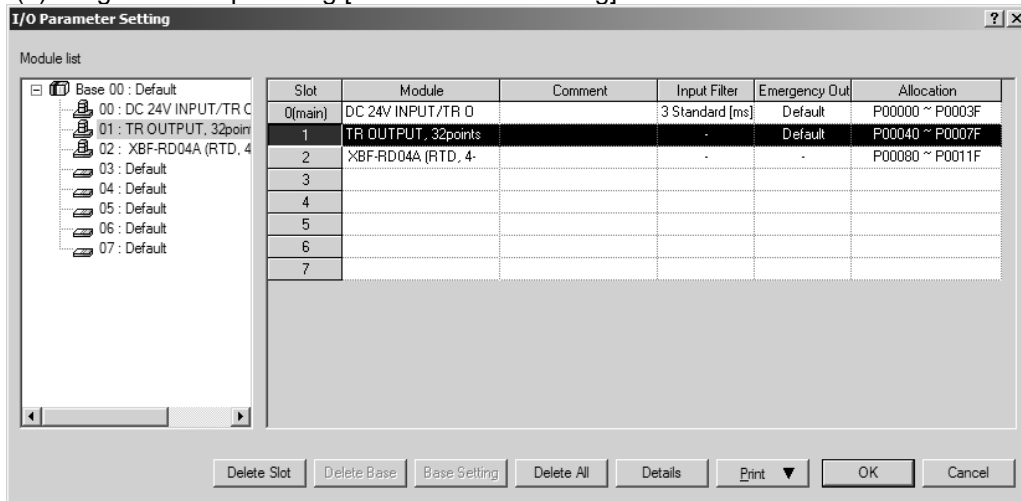

(2) Program example using PUT/GET command

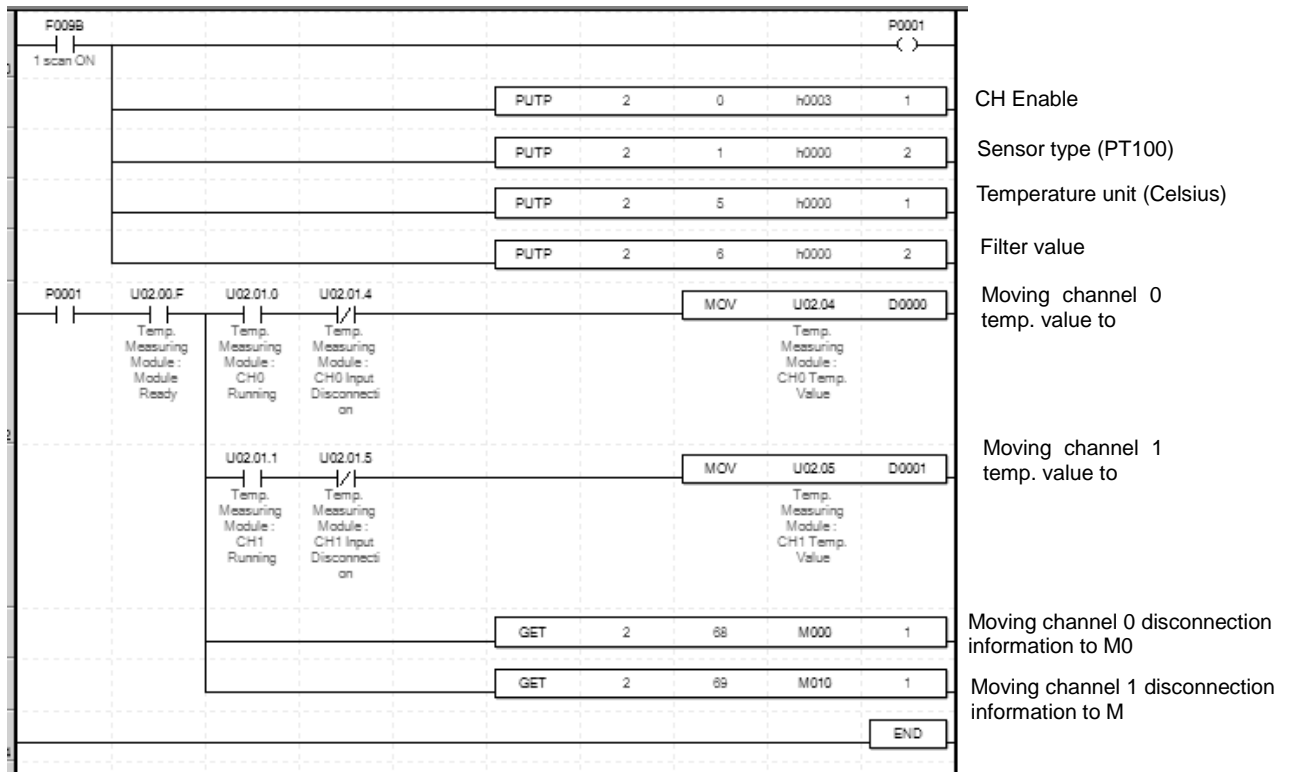

(3) Program example using parameter in case of IEC

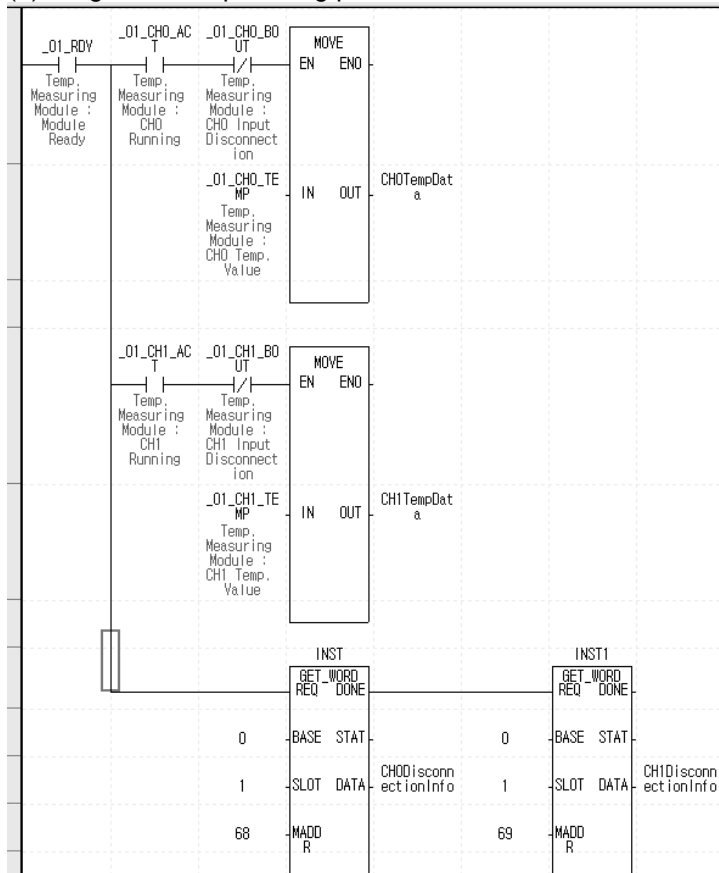

(4) Program example using PUT/GET function block inn case of IEC

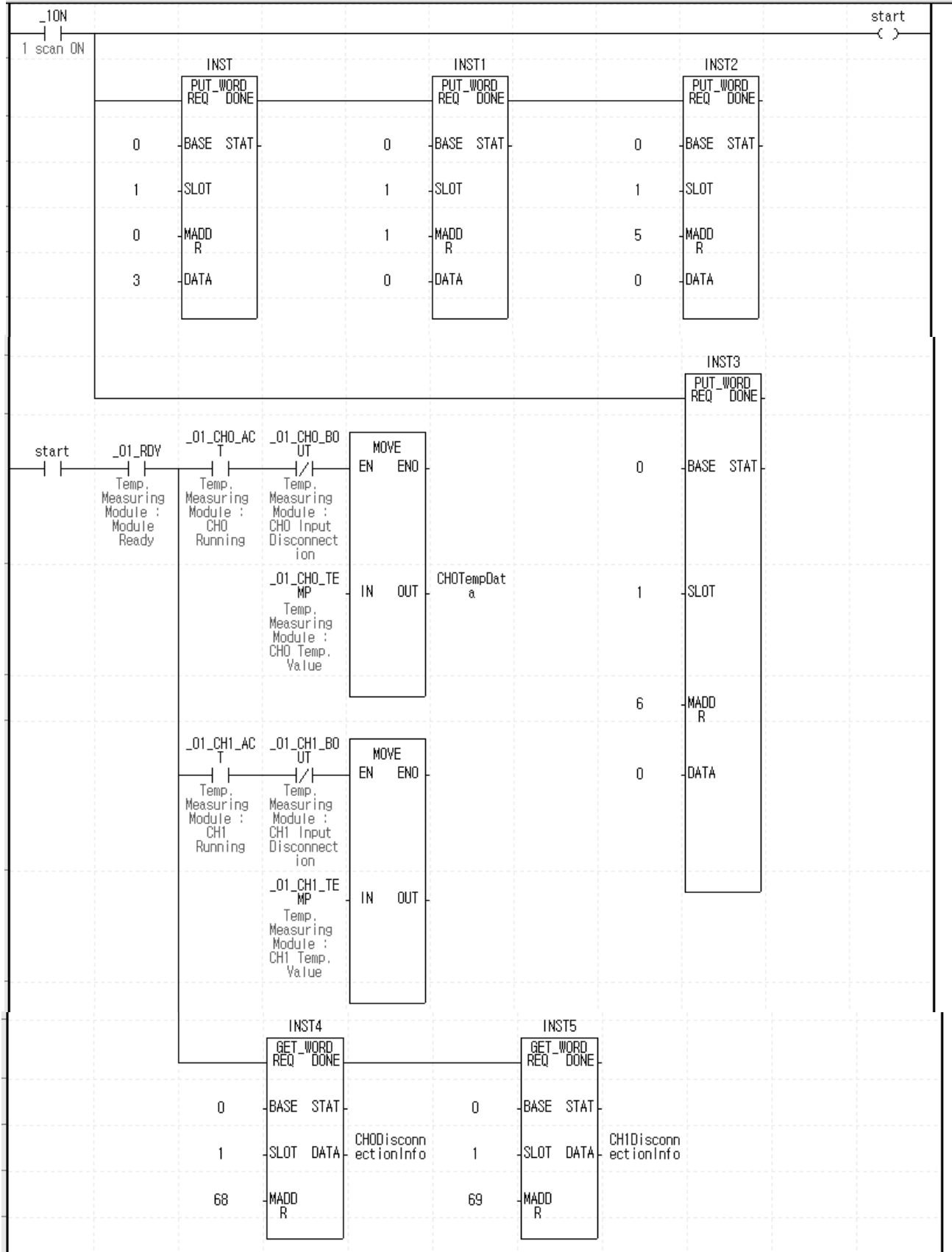



## 4.17 Trouble Shooting

### 4.17.1 RUN LED flickers

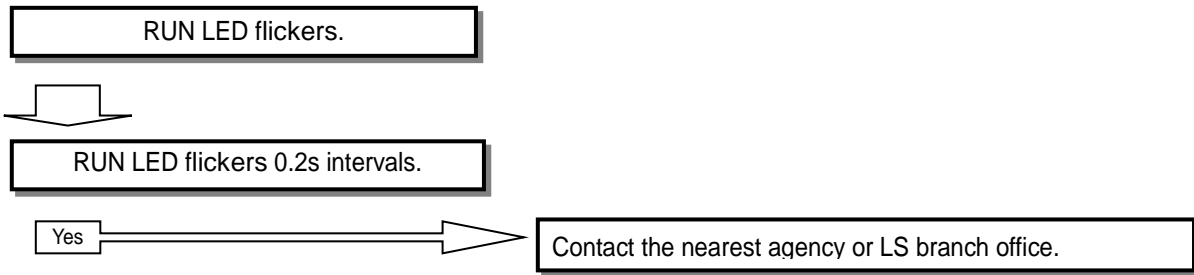

### 4.17.2 RUN LED is off

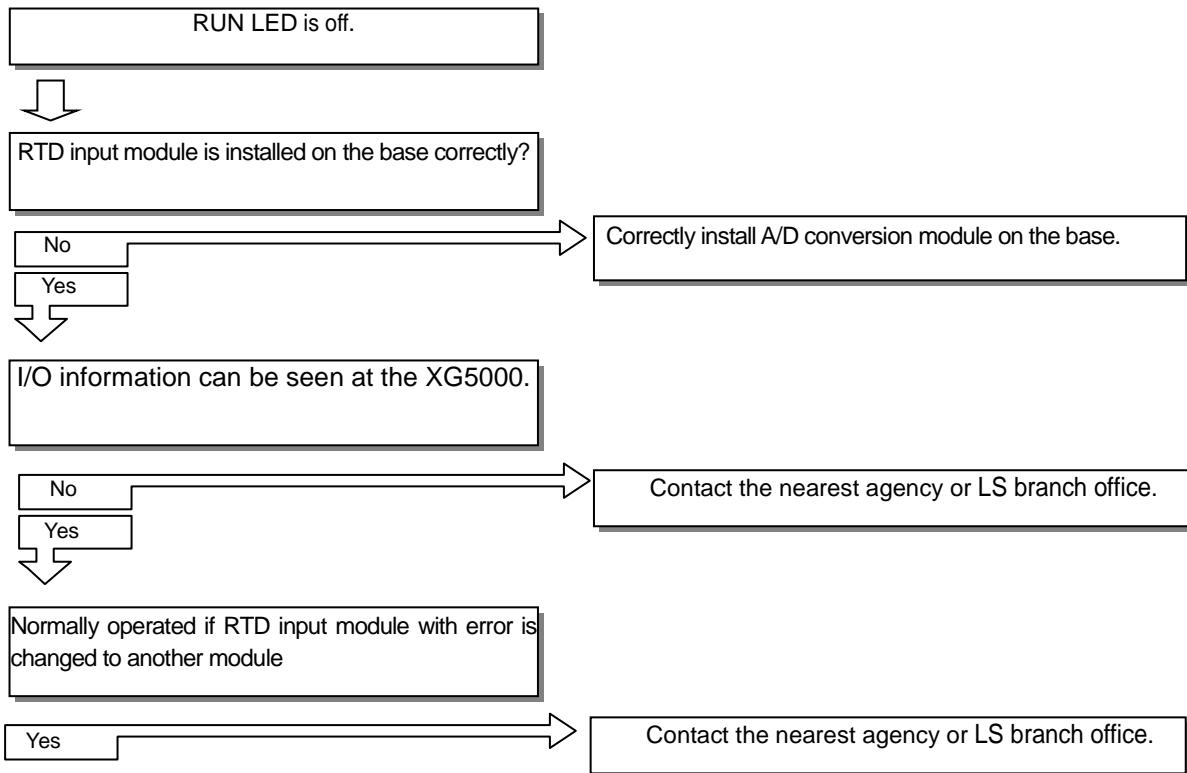

### 4.17.3 ALM (Alarm) LED flickers

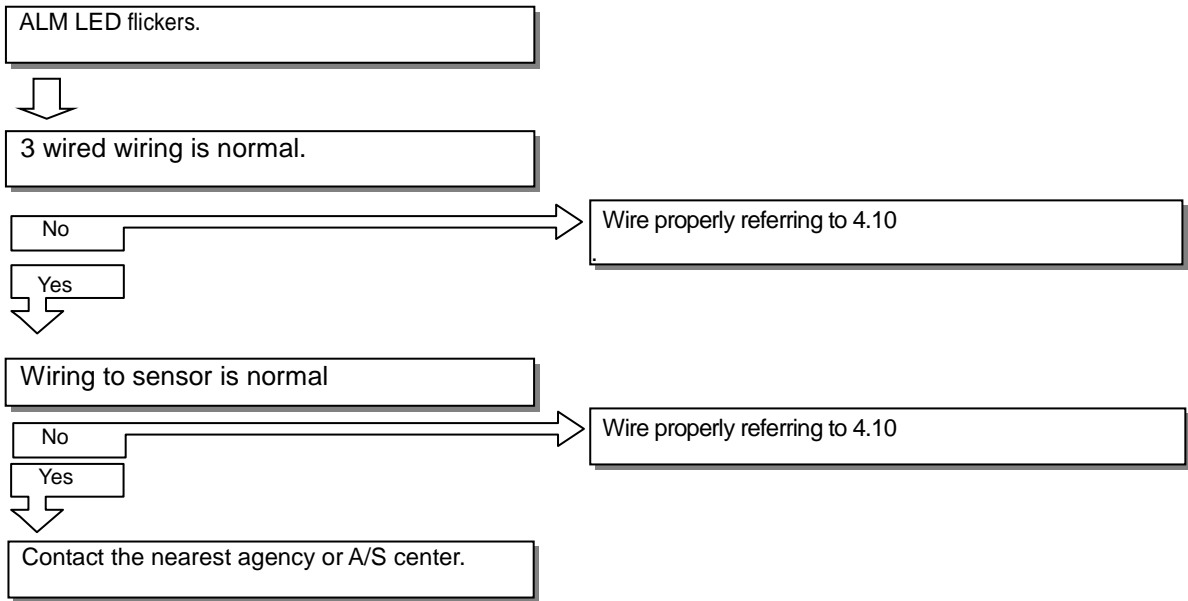

### 4.17.4 Temperature conversion value is not normal.

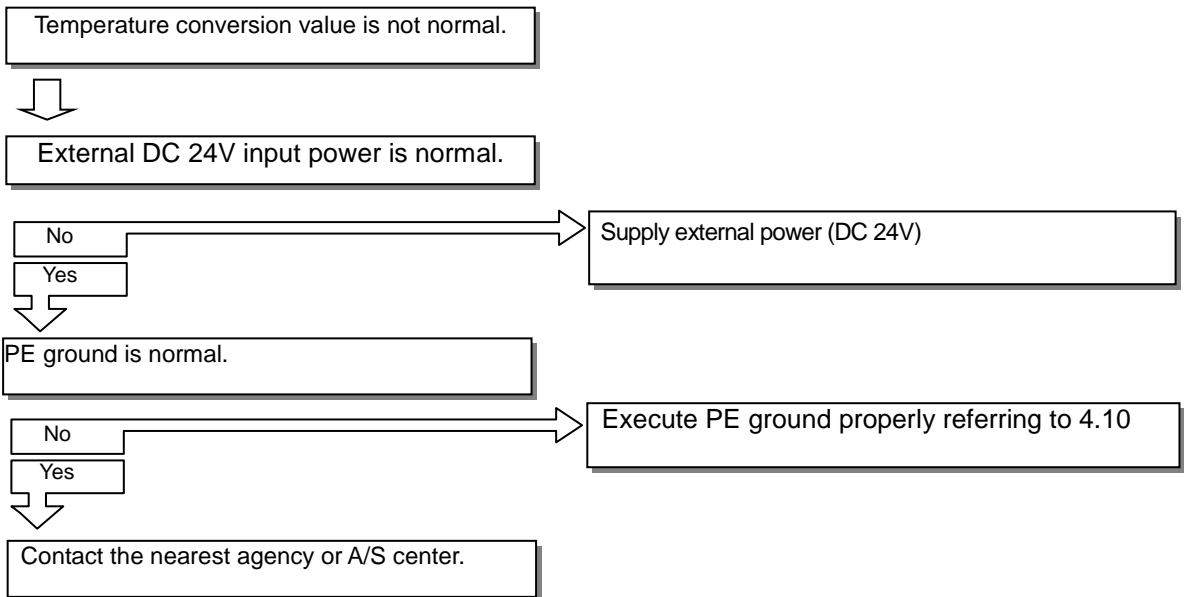

### 4.17.5 Stats check of RTD input module through XG5000 system monitor

Module type, module information, O/S version and module status of RTD input module can be checked through XG5000 system monitoring function.

#### (1) Execution sequence

Two routes are available for the execution.

- (a) [Monitor] -> [System Monitoring] -> And on the module screen, click the right mouse button to display [Module Information].
- (b) [Monitor] -> [System Monitoring] -> And Double-click the module screen.

#### (2) Module information

- (a) Module type: shows the information of the module presently installed.
- (b) Module information: shows the O/S version information of module.
- (c) O/S version: shows the O/S prepared date of module.
- (d) Module status: shows the present error code.

## Chapter 5 Thermocouple Input Module

### 5.1 General

Here describes specification, handling, and programming of XGB thermocouple input module (XBF-TC04S/XBF-TC04B).

Thermocouple input module is used to convert the temperature data detected from thermocouple to signed 16 bit data.

#### 5.1.1 Characteristic

**(1) Module selection according to purpose**

XBF-TC04S/XBF-TC04B: 4 channel input (Insulation between channels by photomos relay)

**(2) Four kinds of thermocouple available (K / J / T / R)**

Available to select the different thermocouple according to each channel

**(3) Voltage input (0 ~ 100mV) available (XBF-TC04B)**

Available to select voltage input (0~100mV) and thermocouple (K type / J type / T type / R type) for each channel

**(4) Disconnection detection**

If thermocouple is disconnected, it is detected and indicated.

**(5) Celsius (°C)/ Fahrenheit (°F) type available**

Temperature conversion data of **Celsius (°C)/ Fahrenheit (°F)** is indicated down to one decimal place

**(6) Temperature data scaling function**

(Available to use it as additional data than temperature indication)

Scaling conversion of temperature data is available within -32,768~32,767/0~65,535.

**(7) Various additional function**

Filter process, Average process (time/count/moving), Max./Min. detection process

**(8) Parameter setting / Monitoring by GUI (Graphical user interface) method**

It enhanced user-friendly features by changing to I/O parameter settings (intensify user interface) from parameter settings by previous instructions.

By [I/O Parameter], the sequence program can be reduced and by [Special Module Monitoring], it is easy to monitor the temperature conversion value.

#### 5.1.2 Required version

When making the system, the version below is required.

Basic unit type	Basic unit name	Type	Required version	
			XBF-TC04S	XBF-TC04B
XGB modular standard type basic unit (XBMS)	XBM-DxxS	Basic unit	Ver 1.8 or above	-
		XG5000	Ver 2.2 or above	-
XGB compact standard type basic unit (XBCS)	XBC-DxxS	Basic unit	Ver 1.8 or above	Ver 1.12 or above
		XG5000	Ver 3.61 or above	Ver 3.62 or above
XGB compact high-end type basic unit (XBCH)	XBC-DxxH	Basic unit	Ver 1.8 or above	-
		XG5000	Ver 2.2 or above	-
XGB IEC high-end type basic unit (XECH)	XEC-DxxH	Basic unit	Ver 1.0 or above	-
		XG5000	Ver 3.0 or above	-

### 5.1.3 Setting sequence before operation

1) Before using the thermocouple input module, follow steps below.

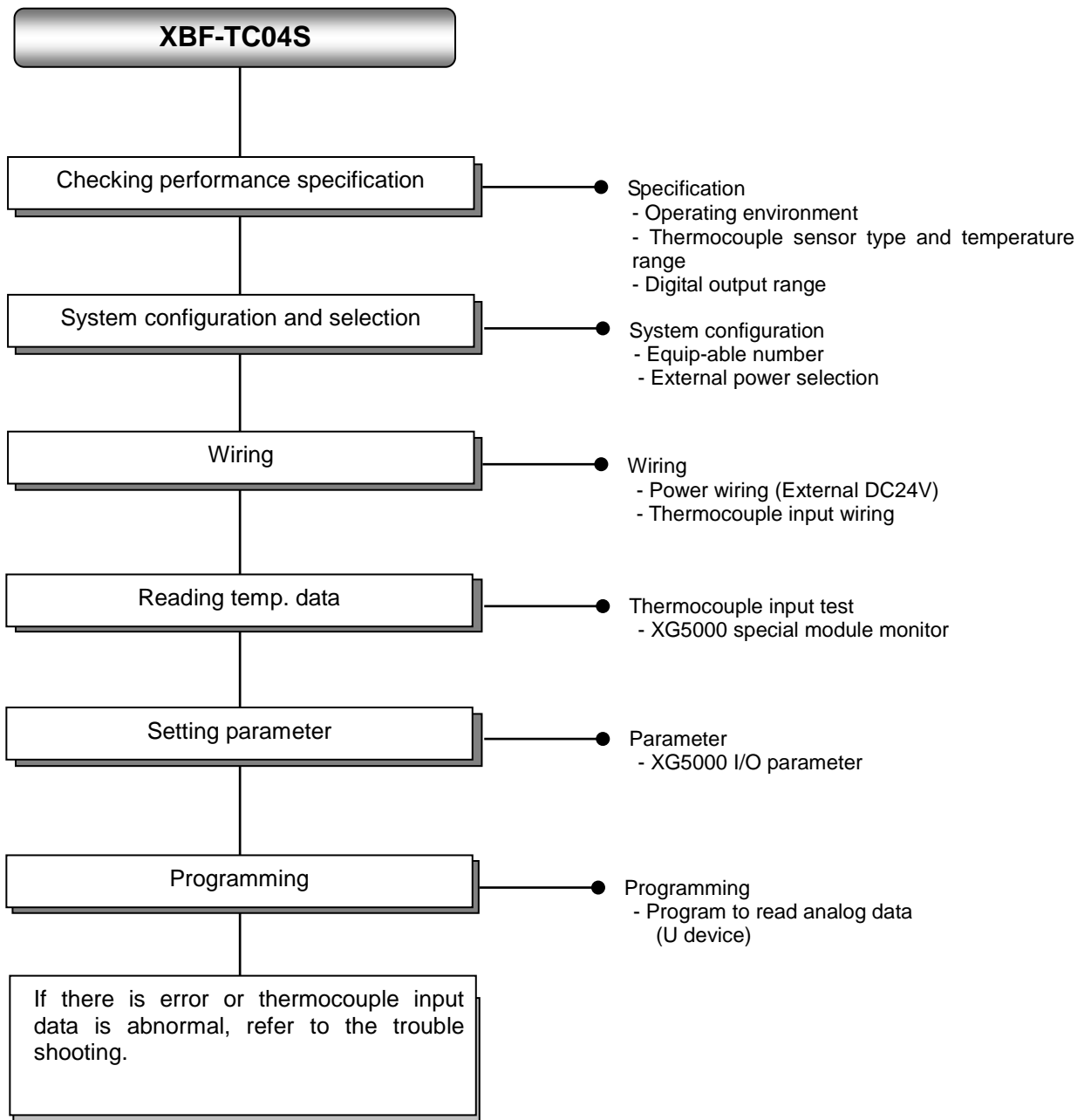

2) Before using the thermocouple/voltage input module, follow steps below.

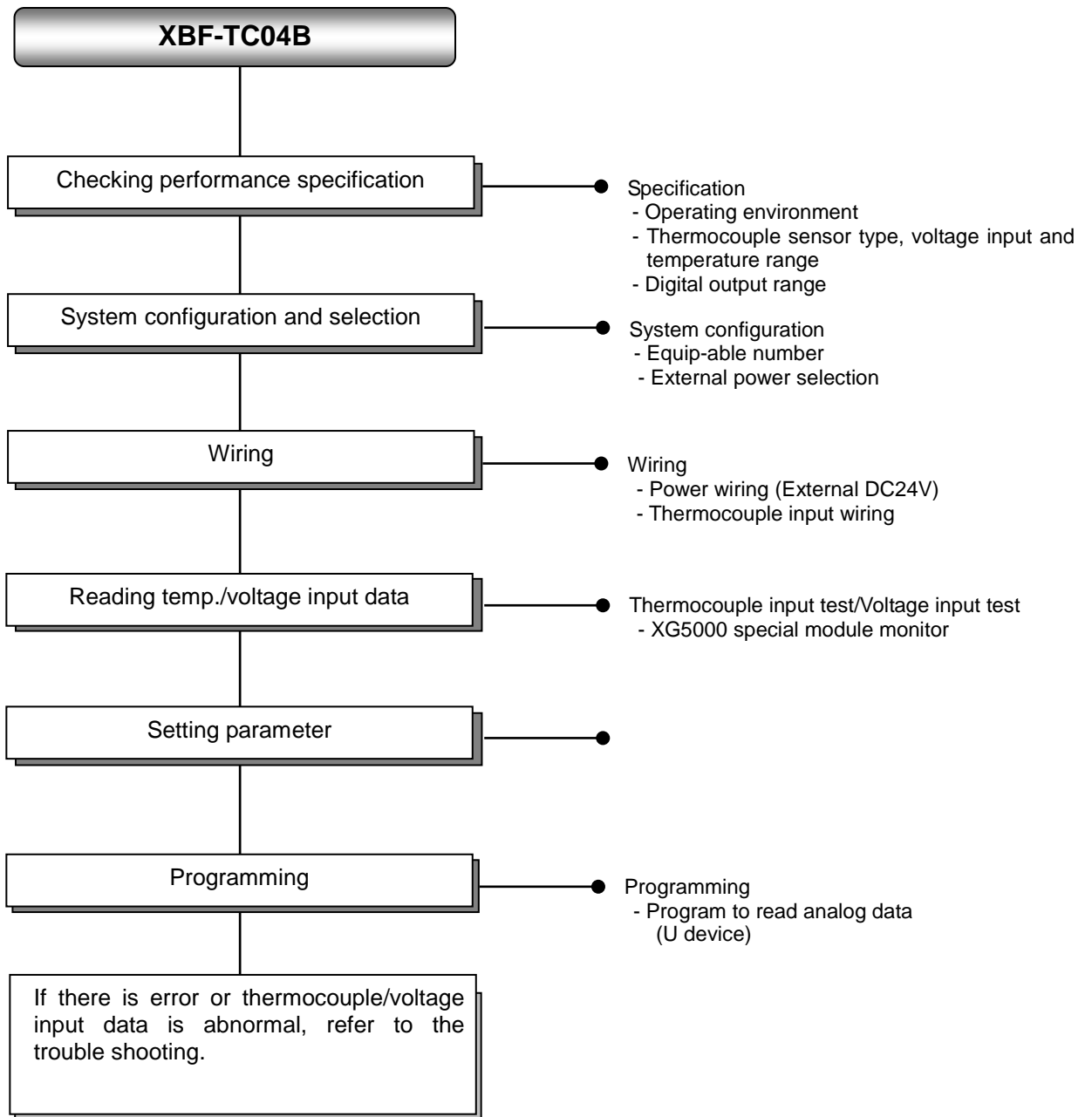

## 5.2 Specification

### 5.2.1 General specification

General specifications are as follows.

No.	Item	Specifications	Related specifications			
1	Ambient temperature	0°C ~ +55°C	-			
2	Storage temperature	-25°C ~ +70°C	-			
3	Ambient humidity	5 ~ 95%RH (Non-condensing)	-			
4	Storage humidity	5 ~ 95%RH (Non-condensing)	-			
5	Vibration resistance	Occasional vibration		-	IEC61131-2	
		Frequency	Acceleration	Amplitude		How many times
		5 ≤ f < 8.4 Hz	-	3.5 mm		10 times each directions (X, Y and Z)
		8.4 ≤ f ≤ 150 Hz	9.8 m/s <sup>2</sup> (1G)	-		
		For continuous vibration				
		Frequency	Acceleration	Amplitude		
		5 ≤ f < 8.4 Hz	-	1.75 mm		
8.4 ≤ f ≤ 150 Hz	4.9 m/s <sup>2</sup> (0.5G)	-				
6	Shock resistance	<ul style="list-style-type: none"> <li>Peak acceleration: 147 m/s<sup>2</sup>(15G)</li> <li>Duration: 11ms</li> <li>Half-sine, 3 times each direction per each axis</li> </ul>	IEC61131-2			
7	Noise resistance	Square wave Impulse noise	AC: ± 1,500V DC: ± 900V	LS ELECTRIC standard		
		Electrostatic discharge	Voltage : 4kV (contact discharging)	IEC 61131-2, IEC 61000-4-2		
		Radiated electromagnetic field noise	80 ~ 1,000 MHz, 10V/m	IEC 61131-2, IEC 61000-4-3		
		Fast transient /bust noise	Segment	Power supply module	Digital/analog input/output communication interface	IEC 61131-2, IEC 61000-4-4
Voltage	2kV		1kV			
8	Environment	Free from corrosive gasses and excessive dust	-			
9	Altitude	Up to 2,000 ms	-			
10	Pollution degree	Less than equal to 2	-			
11	Cooling	Air-cooling	-			

### 5.2.2 Performance Specification

(1) Thermocouple input specification (XBF-TC04S/XBF-TC04B)

Items		Specification
Number of input channel		4 channels Select channel type by parameter (thermocouple input)
Type of input sensor		Thermocouple K / J / T / R type JIS C1602-1995
Range of input temperature	K	-200.0°C ~ 1300.0°C
	J	-200.0°C ~ 1200.0°C
	T	-200.0°C ~ 400.0°C
	R	0.0°C ~ 1700.0°C
Digital output	Temp. display	Displaying down to one decimal place – note1) K, J, T type: 0.1°C, R type: 0.5°C
	Scaling display (user-defined scaling)	Unsigned scaling (0 ~ 65535) Signed scaling (-32768 ~ 32767)
Accuracy	Ambient temperature(25°C)	Within ±0.2% – note 2)
	Temp. coefficient (range of operating temp)	±100 ppm/°C
Conversion time		50ms / channel
Reference junction compensation	Auto compensation by RJC sensing (Thermistor)	
	Compensation amount	±1.0°C
Warming-up time		15 min or above –note 3)

Note1), Note2) For more detail specification, refer to 5.2.6 accuracy/resolution.

Note 3) Warming-up time: for stability of measured temperature, 15 min is necessary after power is on.

(2) Voltage input specification (XBF-TC04B)

Items		Specification
Number of input channel		4 channels Select channel type by parameter (thermocouple/voltage input)
Analog input range		0 ~ 100 mV (Input impedance: 1MΩ or above)
Digital output	Type	0 ~ 20000
	Scaling display (user-defined scaling)	Unsigned scaling (0 ~ 65535) Signed scaling (-32768 ~ 32767)
Max. resolution		1/20000 (0.005mV)
Accuracy	Ambient temperature (25°C)	Within ±0.2%
	Temp. coefficient (operating temp. range)	±100 ppm/°C
Conversion time		50ms / channel



## Chapter 5 Thermocouple Input (XBF-TC04S/TC04B)

### (3) Common specification (XBF-TC04S/XBF-TC04B)

Items		Specification	
Insulation	Insulation method	Terminal – inner circuit	Photo-coupler insulation
		Terminal – operating power	DC/DC converter insulation
		Between channels	Photomos relay insulation
	Dielectric withstand voltage		400 V AC, 50/60 Hz, 1min, leakage current 10mA or below
	Insulation resistance		500 V DC, 10 MΩ or below
Terminal block		11 point terminal	
I/O occupied points		64 points	
Max. number of equipment		7 [When using XBM-Dxxx□ (□: "S", "H", "H2", "HP") type] 7 (when using XB(E)C-DxxxSU type) 10 (when using XB(E)C-DxxxH type or XB(E)C-DxxxU type) Not Available (when using XB(E)C-DxxxE type)	
Additional function	Filter process	Digital filter (200 ~ 64,000ms)	
	Average process	Time average (400~64,000ms)	
		Count average (2~64,000 times)	
		Moving average (2~100)	
	Alarm	Disconnection detection	
	Max./Min. display	Display Max./Min.	
Scaling function	Signed scaling / Unsigned scaling		
Consumption current	Inner DC5V	100mA	
	External DC24V	100mA	
Weight		63g	

### 5.2.3 Name of part and function

Respective designations of the parts are as described below

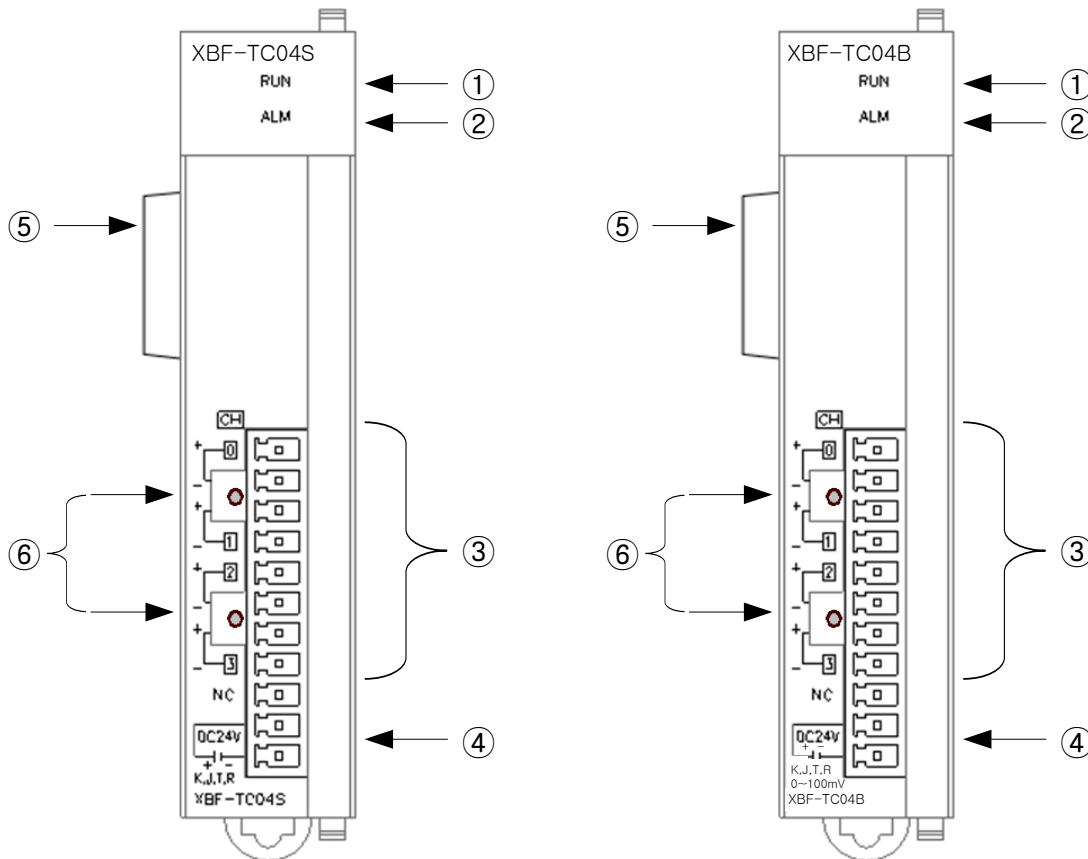

No.	Name	Description
①	RUN LED	▶ Displays the status of thermocouple input module On: operation normal Flickering: Error occurs (0.2s flickering) Off: power Off or module error
②	ALM LED	▶ Displays the disconnection status of thermocouple input module (Alarm indication LED) Flickering: Disconnection error occurs (1s flickering) Off: operation normal
③	Terminal block	▶ Terminal block for wiring to connect the thermocouple (K, J, T, R type) (0~100mV, XBF-TC04B)
④	External power supply terminal	▶ Terminal for supply of external DC24V
⑤	Connector for extension	▶ Connection connector for connecting the extension module
⑥	Reference junction compensator	▶ Thermistor for reference junction compensation (RJC)

### 5.2.4 Characteristic of thermocouple temperature conversion

Thermocouple input module connect 4 kinds of thermocouple and one voltage input (XBF-TC04B) directly, input characteristic are as described below.

**(1) Thermocouple K (JIS C1602-1995): -200 °C(-5891  $\mu$ V) ~ 1300 °C(52410  $\mu$ V)**

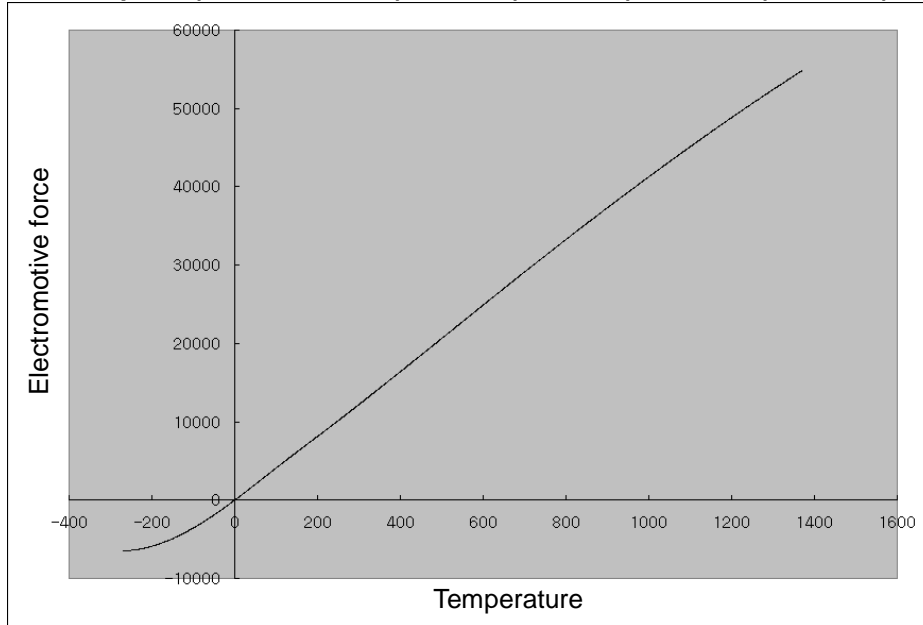

**(2) Thermocouple J (JIS C1602-1995): -200 °C(-7890  $\mu$ V) ~ 1200 °C(69553  $\mu$ V)**

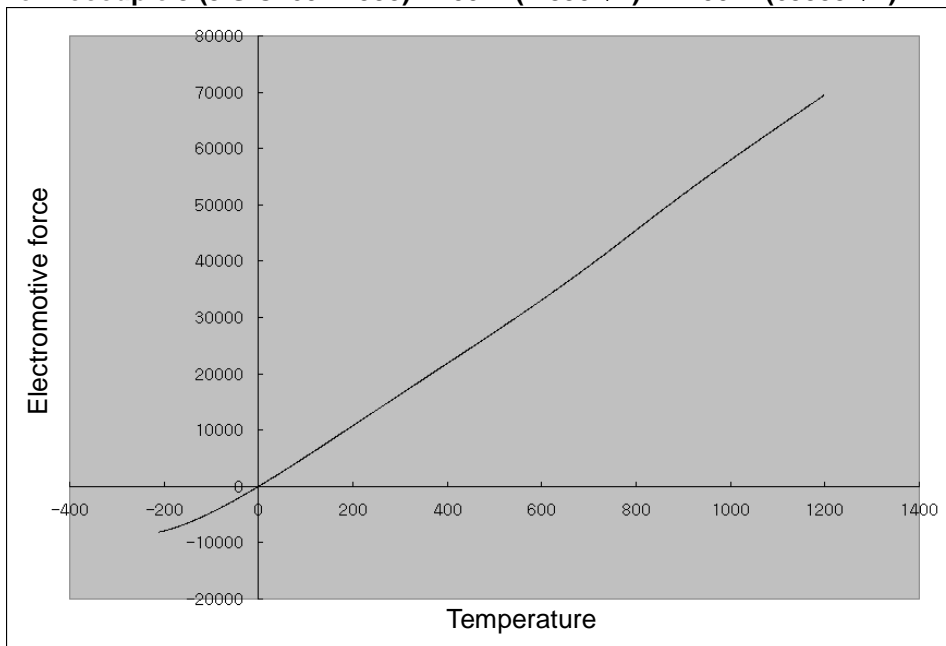

(3) Thermocouple T (JIS C1602-1995): -200 °C (-5603 μV) ~ 400 °C (20872 μV)

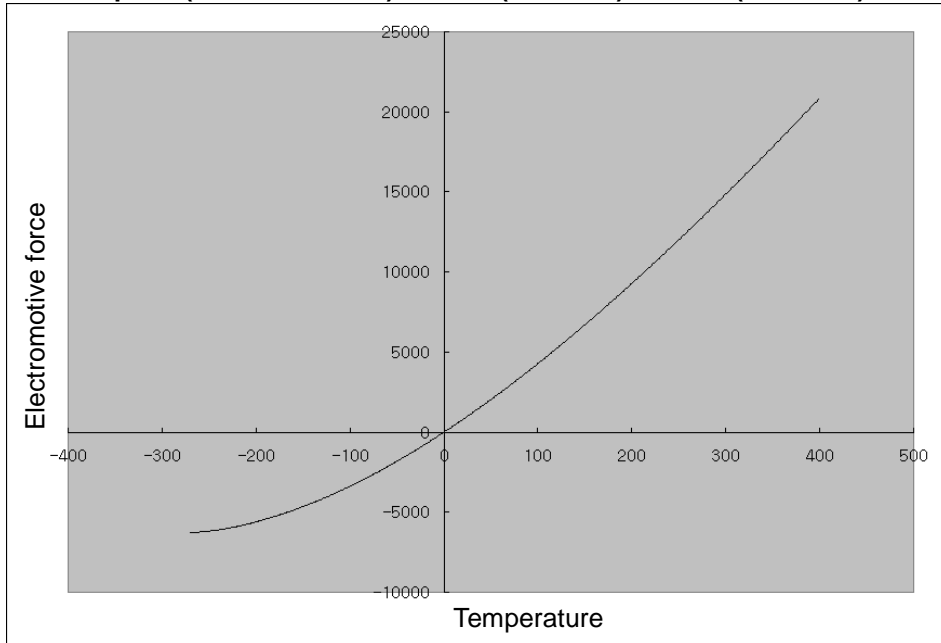

(4) Thermocouple R (JIS C1602-1995): 0 °C (0 μV) ~ 1700 °C (20222 μV)

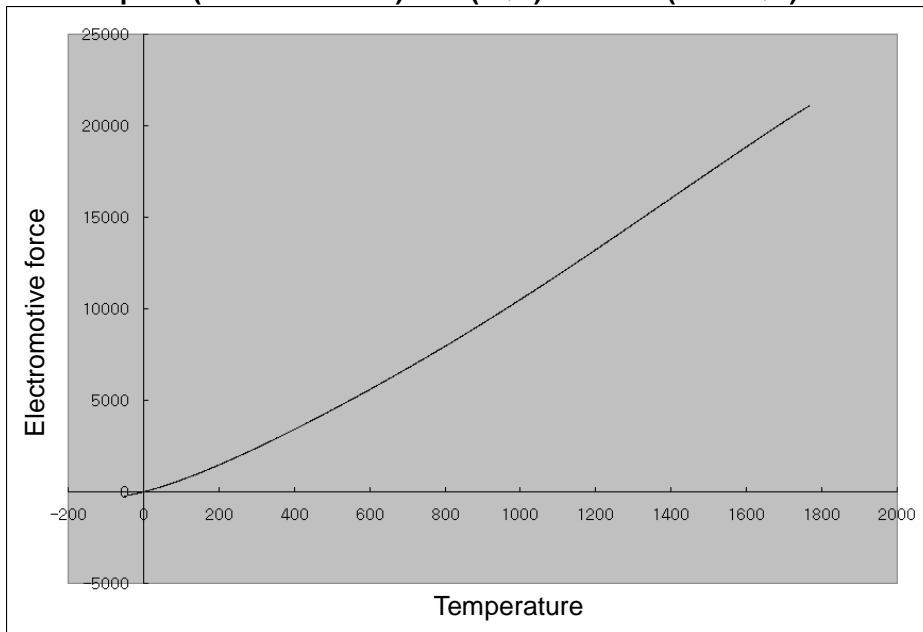

**Remark**

Thermocouple characteristics: thermocouple sensor measures temperature by using fine voltage (electromotive force), which occurs when applying temperature gradient to a junction between two different metals.

The temperature-electromotive force relation specification of normal thermocouple sensor provides the electromotive force, which is measured when a sensor's measuring point is at 0 °C. On that account, when measuring temperature by using thermocouple sensor, cold junction compensation (reference junction compensation, RJC) is used. (built-in function of temperature measuring module).

**(5) Temperature conversion characteristic**

Thermocouple input module converts the thermocouple input with non-linear characteristics into A/D and outputs the temperature conversion that is linearly treated. Temperature conversion to thermocouple input has non-linear characteristics.

**Remark**

Non-linear characteristics: regarding the relation of temperature(°C) and electromotive force( $\mu V$ ) of a thermocouple sensor, electromotive force is different by sections even though temperature changes by a certain amount, which is called 'non-linear characteristics.' As seen in the above graph, it is shown that the relation of temperature and electromotive force is a curve by temperature sections. The module processes the non-linear characteristics table as linear.

**(6) Voltage input range (0 ~ 100mV)**

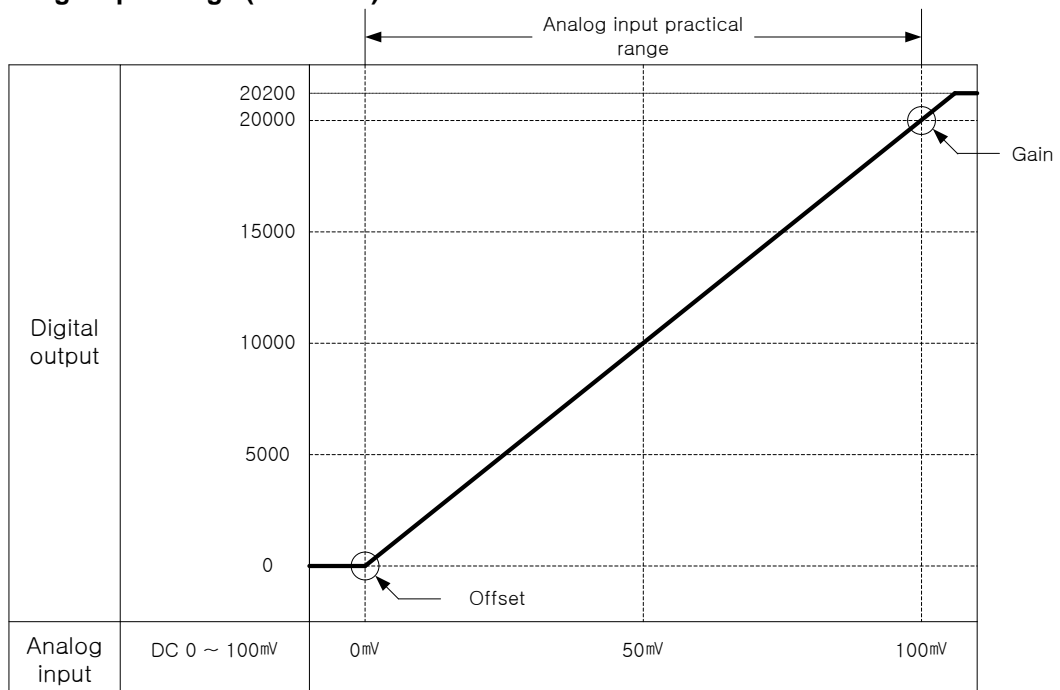

### 5.2.5 Temperature display

- (1) Temperature is displayed down to one decimal place.  
 In the XG5000, when monitoring the temperature conversion value, select “Signed decimal”  
 According to monitor indication type, temperature is monitored like figure below.

Ex.) if displaying -123.0°C by converting, the value stored in the internal memory would be -1230.

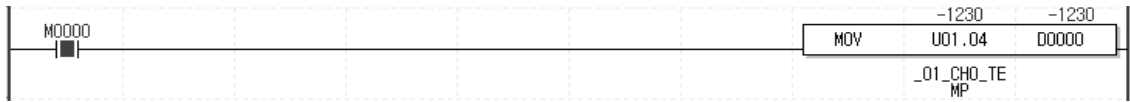

Monitor indication type	Indication contents
Unsigned decimal	64306
Signed decimal	-1230 (-123.0°C)
Hexadecimal	hFB32
As instruction	64306

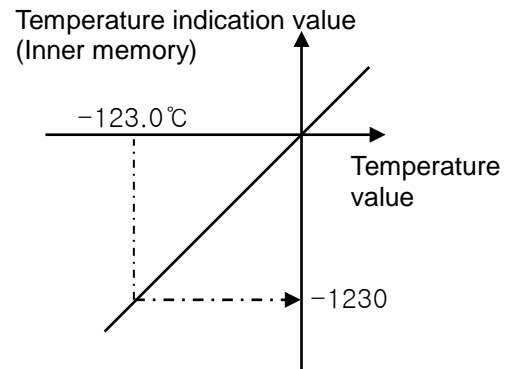

- (2) Temperature display unit  
 (a) K, J, T type: 0.1°C  
 (b) R type: 0.5°C
- (3) Temperature may be displayed by Celsius or Fahrenheit, depending on the settings.

Ex.) if displaying 100 °C in Fahrenheit, it would be 212 F by using the following formula.

(a) From Celsius to Fahrenheit degree  $F = \frac{9}{5}C + 32$

(b) From Fahrenheit to Celsius degree  $C = \frac{5}{9}(F - 32)$

### 5.2.6 Accuracy / Resolution

Accuracy / Resolution are as follows according to ambient temperature

Thermocouple type	Measurement temperature range	Indication temperature range	Accuracy - note1)		resolution
			Normal temperature (25 °C)	Operating temperature - note2) (0 °C ~ 55 °C)	
K	-200.0 °C ~ 1300.0 °C	-270.0 °C ~ -200.0 °C	- note3)		0.2 °C
		-200.0 °C ~ 0.0 °C	±3.0 °C	±7.5 °C	
		0.0 °C ~ 1300.0 °C	±3.0 °C	±7.5 °C	
		1300.0 °C ~ 1372.0 °C	- note3)		
J	-200.0 °C ~ 1200.0 °C	-210.0 °C ~ -200.0 °C	- note3)		0.2 °C
		-200.0 °C ~ -100.0 °C	±2.8 °C	±7.0 °C	
		-100.0 °C ~ 1200.0 °C	±2.8 °C	±7.0 °C	
T	-200.0 °C ~ 400.0 °C	-270.0 °C ~ -200.0 °C	- note3)		0.1 °C
		-200.0 °C ~ 400.0 °C	±1.2 °C	±3.0 °C	
R	0.0 °C ~ 1700.0 °C	-50.0 °C ~ 0.0 °C	- note3)		0.5 °C
		0.0 °C ~ 1700.0 °C	±3.5 °C	±8.5 °C	
		1700.0 °C ~ 1768.0 °C	- note3)		

Note1) Total accuracy (normal temp.) = accuracy (normal temp.) + cold junction compensation accuracy  
=  $\pm(\text{full scale} \times 0.2\% + 1.0\text{ }^\circ\text{C})$

Cold junction compensation accuracy =  $\pm 1.0\text{ }^\circ\text{C}$

Note2) Temp. coefficient:  $\pm 100\text{ ppm}/^\circ\text{C}$

Note3) Measuring the temp. is available, but accuracy and resolution is not guaranteed.

(1) When ambient temp. is normal ( $25 \pm 5\text{ }^\circ\text{C}$ ): within the  $\pm 0.2\%$  range of measurement temp.

(2) When ambient temp. is operating temp. ( $0 \sim 55\text{ }^\circ\text{C}$ ): within the  $\pm 0.5\%$  range of measurement temp.

Ex.) When K type thermocouple is used and ambient temperature is normal.

In case of measuring  $1000\text{ }^\circ\text{C}$  temperature, output range of conversion data is  
 $1000\text{ }^\circ\text{C} - \{[1300 - (-200)] \times 0.2\% \} - 1 \sim 1000\text{ }^\circ\text{C} + \{[1300 - (-200)] \times 0.2\% \} + 1$   
 namely,  $996.0 \sim 1004.0\text{ }^\circ\text{C}$ .

#### Note

- (1) For stabilization of measurement temperature, warming-up time more than 15 min. is necessary, after restart.
- (2) If ambient temperature changes rapidly, measurement temperature may change temporally. Keep the ambient temperature steady for stabilization of measuring temperature.
- (3) If wind of the cooling fan contacts with module directly in the panel, accuracy decreases. Do not contact with wind directly.

### 5.2.7 Conversion velocity

- (1) Conversion velocity per channel: 50ms/channel
- (2) Sequential process method  
 The next channel is converted after conversion of one channel is completed.  
 (Run/Stop of the respective channels can be set independently.)
- (3) Concept of conversion time

The conversion velocity of XBF-TC04S module is a cycle that the temperature (electromotive force) entered into terminal strip is converted into digital value and stored in internal memory.

Conversion time increase by a multiple of the no. of used channels

$$\therefore \text{Conversion time} = 50\text{ms} \times \text{no. of used channels}$$

Ex.) In case 3 channels is used: conversion time = 50ms X 3 = 150ms

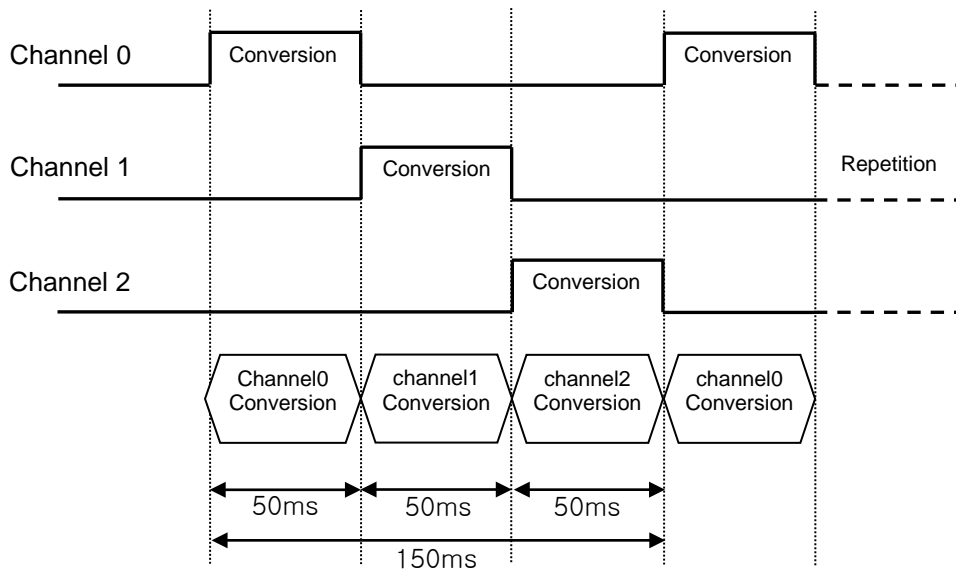



## 5.3 Function

### 5.3.1 Disconnection detection function

Thermocouple input module has a function to detect the disconnection and display it. That the module detects and displays disconnection means that the following cabling path would have partially bad connection, which requires taking measures

- (1) Disconnection occurs between a sensor used/compensating cable and module, LED(ALM) flickers every second and generates error code.
- (2) Disconnection can be detected by channels. However, it is available for the only channel(s) designated for operation. LED (ALM) is commonly used for every channel. It flickers in case even only one channel is disconnected.

Thermocouple connection status	Channel run	ALM LED status	Disconnection flag
Normal	Run	Off	Off
	Stop	Off	Off
Thermocouple disconnection	Run	Flickering (1s)	On
	Stop	Off	Off

- (3) In case disconnection occurs, disconnection flag of each channel will be turned on and in case disconnection is canceled, it will be turned off.

Disconnection flag	Contents
U0x.01.4	Ch. 0 disconnection
U0x.01.5	Ch. 1 disconnection
U0x.01.6	Ch. 2 disconnection
U0x.01.7	Ch. 3 disconnection

- (4) When disconnection occurs, the min value among range is displayed.

Type	Displayed temperature in case of disconnection
K type	-270.0℃
J type	-210.0℃
T type	-270.0℃
R type	-50.0℃

Type	Displayed value in case of disconnection
0 ~ 100mV (XBF-TC04B)	0

### 5.3.2 Scaling function

Thermocouple input module has a function to scale value in user-defined range besides temperature display. The scope is classified into two types; 16 bits data type, -32768~32767 and 16 bits data type without mark, 0~65535. If a user selects one of these two types and sets the range, it displays the temperature through scaling operation.

Scaling data type	Scaling min. value	Scaling max. value
Signed value	-32768 ~ [Scaling max. value -1]	[Scaling min. value+1] ~ 32767
Unsigned value	0 ~ [Scaling max. value-1]	[Scaling min. value+1] ~ 65535

The following graph indicates relation between scaled value and temperature input.

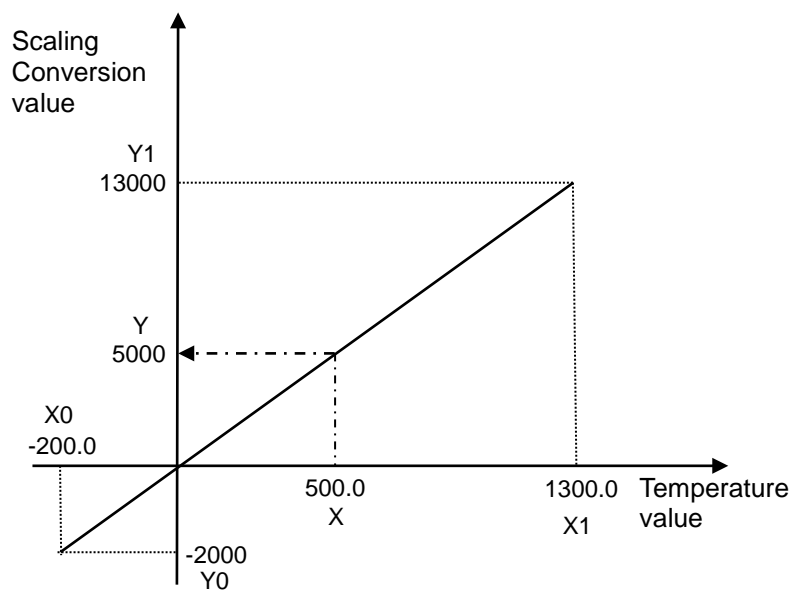

$$\text{Scaling operation: } Y = \frac{(Y1 - Y0)}{(X1 - X0)}(X - X0) + Y0$$

- X = Temperature value
- X0 = Thermocouple measurement min. temperature value
- X1 = Thermocouple measurement max. temperature value
- Y0 = Scaling min. value
- Y1 = Scaling max. value
- Y = Scaling

Ex.) If scaling with mark is set with -2000 ~ 13000 and the temperature measured K type sensor is 500.0°C, the value scaled is as follows.

- Scaling conversion value =  $\frac{(13000 - (-2000))}{(1300 - (-200))}(500 - (-200)) + (-200) = 5000$

### 5.3.3 Filter function

By means of filter value (time constant 63.2%) setting temperature conversion of a designated channel, it operates and outputs as follows.

$$\text{Filtered temp. value} = \frac{(\text{previously filtered temp. value} \times \text{filter value}_{\text{ms}}) + (\text{present input temp. value} \times 50_{\text{ms}} \times \text{No. of channel used})}{\text{Filter value}_{\text{ms}} + (50_{\text{ms}} \times \text{No. of channels used})}$$

Filter constant setting range = 200 ~ 64000 [ms]

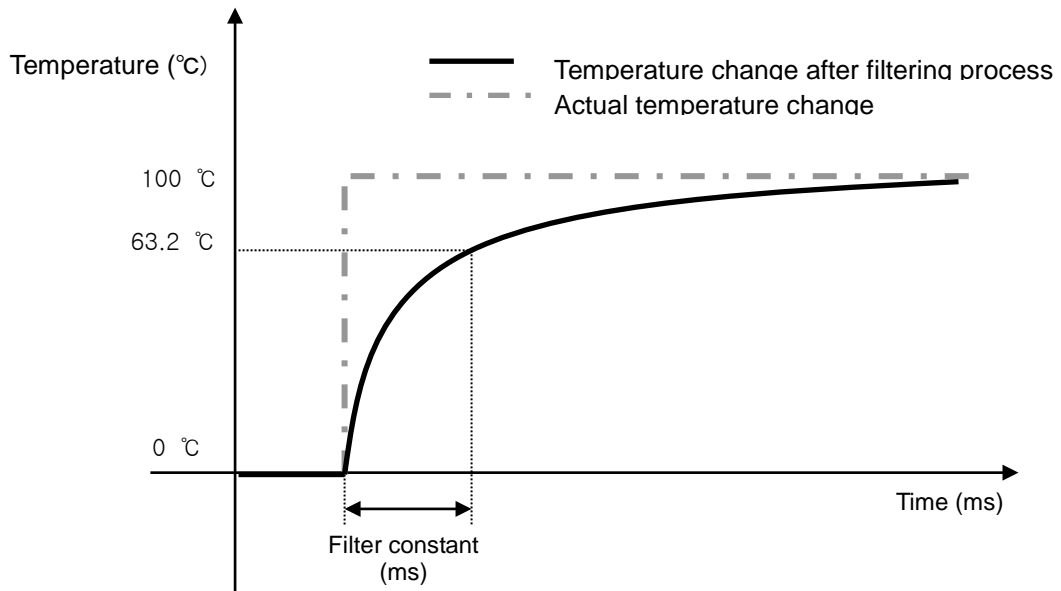

### 5.3.4 Average function

(1) Time average

It accumulates temperature conversion values of a selected channel and displays the average of the total sum in digital data.

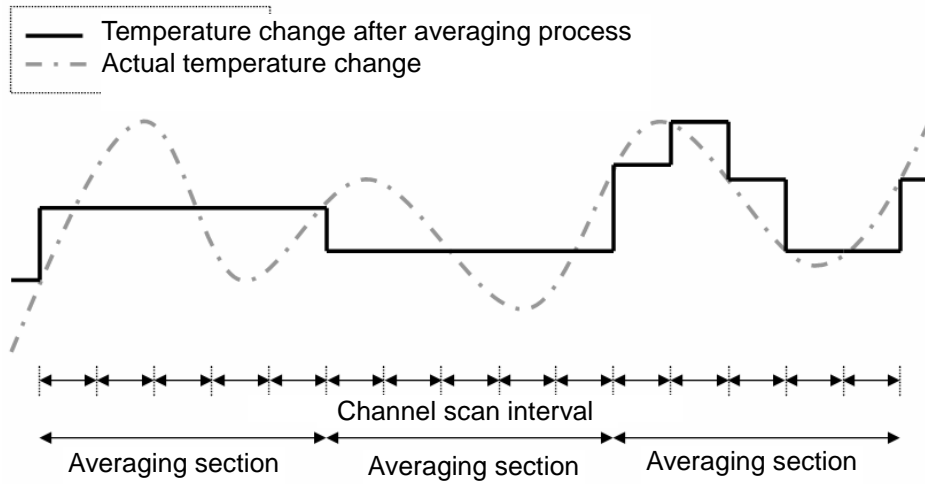

Setting range of average time = 400 ~ 64000 [ms]

Frequency of average process for a preset time can be calculated as follows.

$$\text{Average Process Frequency [times]} = \frac{\text{Average time}_{ms}}{\text{No. of channel used} \times 50_{ms}}$$

(2) Averaged frequency

It accumulates temperature conversion values of a selected channel as many as frequency and displays the average of the total sum in digital data.

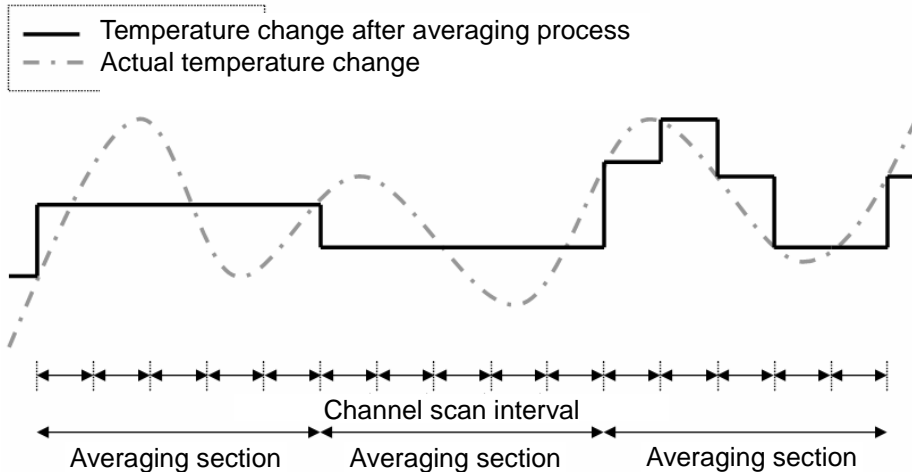

Setting range of average frequency = 2 ~ 64000 [times]

Average process interval of channel used can be calculated as follows

$$\text{Average process interval}[ms] = \text{Average frequency} \times \text{No. of channel used} \times 50[ms]$$

(3) Moving average

It accumulates temperature conversion values of a selected channel as many as set and displays the average of the total sum in digital data. In case of the moving average, it outputs average per scan.

Setting range of average number = 2 ~ 100

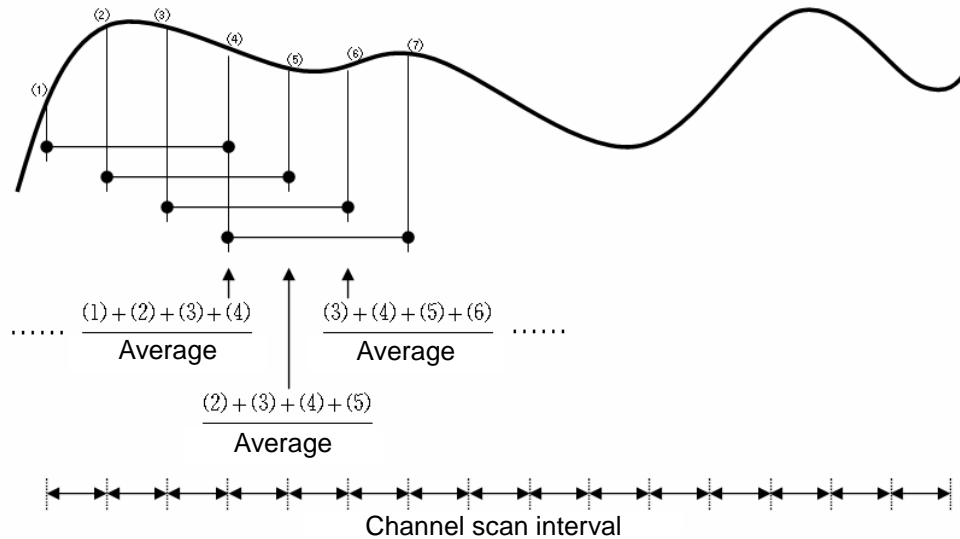

**Remark**

- (1) time/frequency average characteristically does not output temperature data every conversion time and instead, it keeps a feature to maintain the previous status until it reaches time/average frequency.
- (2) In case of moving average, it outputs the converted temperature as taking temperature history and average, which are entered previously, every conversion time, so it can obtain relatively faster data response than time/frequency average.
- (3) Filtering can be processed with one of the foresaid averaging functions simultaneously. If simultaneous process is selected, filtering would be processed first and it averages and output temperature value in digital value. At the moment, the digital data output (temperature) is displayed as the value gained after the final process.

**5.3.5 Max./Min. display**

It displays maximum/minimum value of temperature conversion value of a selected channel for a selected section (a section allowed for max./min. search)

Status of command allowing/prohibiting max./min. search

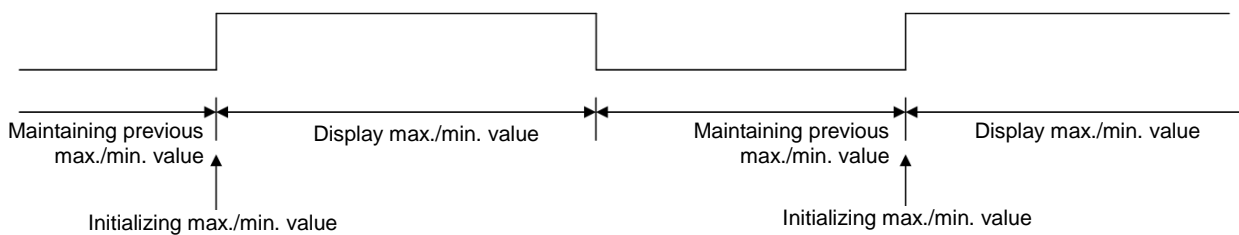

## 5.4 Installation and Wiring

### 5.4.1 Installation environment

Although the device can be installed with high reliance regardless of installation environment, attention should be paid to the followings in order to secure the reliance and stability of the system.

(1) Environmental Conditions

- (a) Install on a water-proof and dust-proof control board.
- (b) Place free of continuous impact or vibration.
- (c) Place not directly exposed to direct sunrays.
- (d) Place where dew does not form due to rapid temperature change.
- (e) Place where ambient temperature is maintained between 0 - 55 °C.

(2) Installation Construction

- (a) In case of screw hole processing or wiring construction, wiring dregs should not go into PLC.
- (b) Install on a position easy to access.
- (c) Should not install on the same panel which high voltage device is installed on.
- (d) It should be 50mm and longer distant from duct and modules.
- (e) Should ground in the environment where is not interrupted from noise.
- (f) Install not to contact with cooling pan in the panel

(3) Cautions in handling

It describes caution in handling from unpacking module to installation.

- (a) Do not fall or apply excessive impact on it.
- (b) Never attempt to separate PCB from the case.
- (c) Make sure that any impurities including wiring dregs should not go into the upper part of module during wiring work.
- (d) Never attempt to attach or detach the module when it is turned on.

### 5.4.2 Wiring

(1) Cautions in wiring

- (a) Do not place AC power line close to the AUX signal line of the module. To avoid surge or induced noise occurring from AC, make sure to leave a proper space.
- (b) Cable should be selected by considering ambient temperature and allowable current and the specification of cable should be as follows.

Cable specification	
Lower limit	Upper limit
0.18mm <sup>2</sup> (AWG24)	1.5 mm <sup>2</sup> (AWG16)

- (c) If cable is placed too close to any heating device or materials or if it directly contacts oil and similar materials for a long time, it may cause short-circuit, resulting in breakdown and malfunction.
- (d) Check the polarities during terminal strip wiring
- (e) Wiring with high voltage cable or power line may cause induction problem, causing malfunction or trouble.
- (f) External DC24V power should be same with power of XGB. If external DC24 V power of thermocouple input module is turned on/off while power of XGB main unit is on, temperature input value may have an error.
- (g) Thermocouple input module may use 4 types of thermocouple sensors. (K / J / T / R)

### (2) Terminal array

Terminal array of thermocouple input module is as follows.

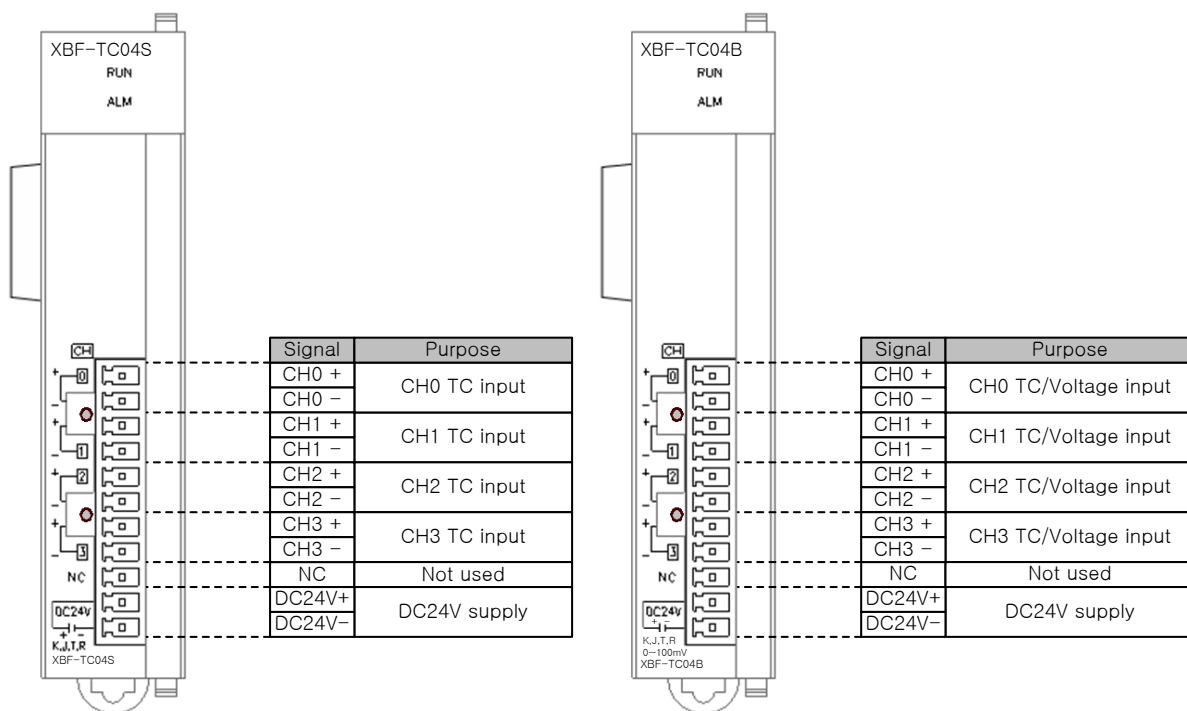

### (3) Wiring example

Thermocouple can be connected with module directly. If point where temperature is measured is far from the module, use the compensating cable to connect (The compensating cables are different according to thermocouple type. For more information about the compensating cable, contact the producer of thermocouple.)

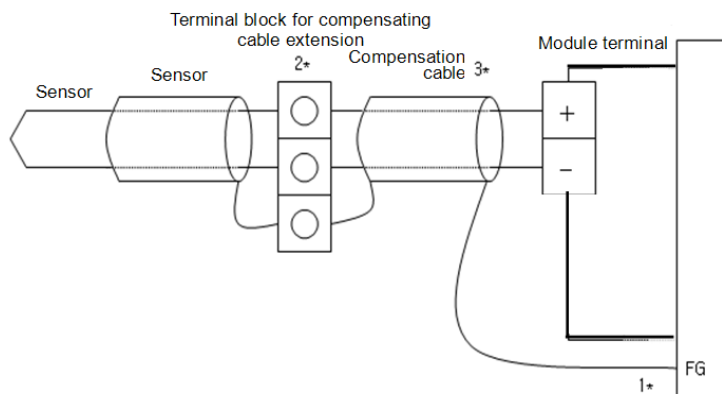

- 1) In case sensor and compensating cable are shielded, shield connection is possible to PLC PE terminal.
- 2) It is necessary to use extension terminal block of which material is kept at uniform temperature in order to reduce error.
- 3) Compensating cable should use the same type of sensor, which was used for measuring.

(4) Voltage (0~100mV) input wiring example

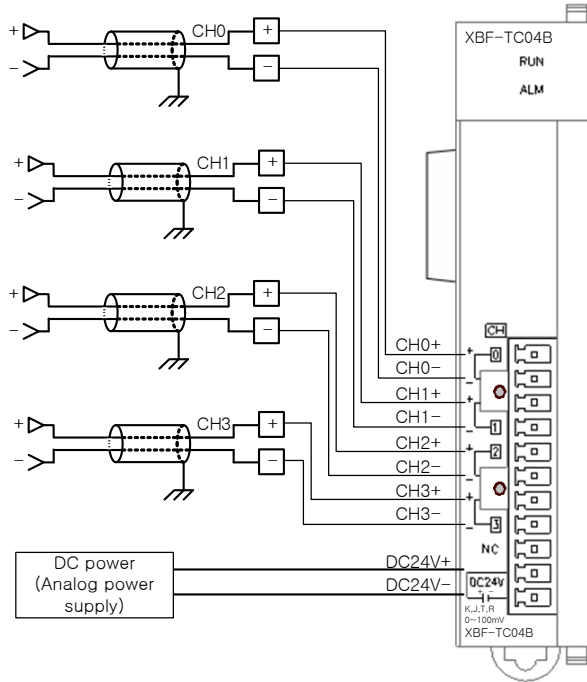

Input resistance of voltage input circuit is 1 MΩ (min.).

(5) Relationship between voltage input accuracy and wiring length

In voltage input, the wiring (cable) length between transmitter or sensor and module has an effect on digital-converted values of the module as specified below;

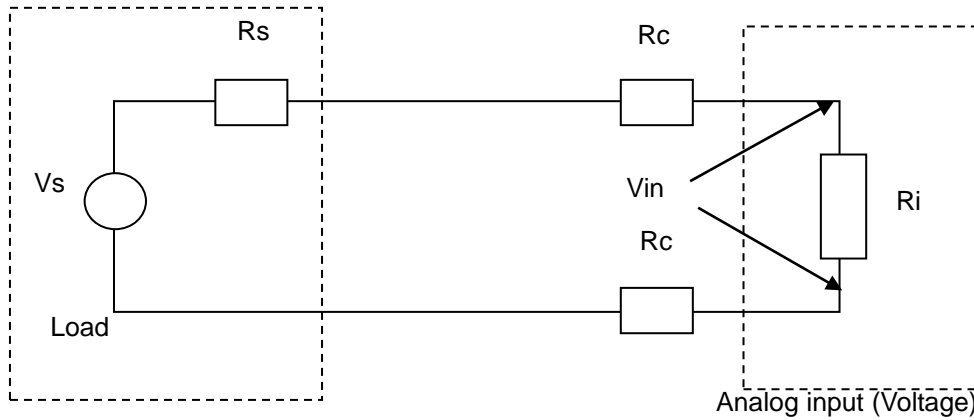

Where,

$R_c$ : Resistance value due to line resistance of cable

$R_s$ : Internal resistance value of transmitter or sensor

$R_i$ : Internal resistance value (1MΩ) of voltage input module

$V_{in}$ : Voltage allowed to analog input module

%  $V_i$ : Tolerance of converted value (%) due to source and cable length in voltage input

$$V_{in} = \frac{R_i \times V_s}{[R_s + (2 \times R_c) + R_i]}$$

$$\% V_i = \left(1 - \frac{V_{in}}{V_s}\right) \times 100\%$$



## 5.5 Operation Setting and Monitor

### 5.5.1 Operation Parameter Setting

Operation parameter of thermocouple input module can be set through [I/O Parameter] of XG5000.

#### (1) Setting items

For user convenience, parameter setting of thermocouple input module is provided by GUI (Graphical User Interface) method in the XG5000. The items which can be set through [I/O Parameter] in the project window are as follows.

Items	Content
[I/O Parameter]	(a) Sets the following items for operation of module. <ol style="list-style-type: none"> <li>1) Channel status (Disable / Enable)</li> <li>2) Sensor status (K / J / T / R)</li> <li>3) Filter constant</li> <li>4) Average processing (Sampling / Time-Avr. / Count-Avr. / Moving-Avr.)</li> <li>5) Scaling data type (Bipolar / Unipolar)</li> <li>6) Scaling min./max. value</li> </ol> (b) The parameter set by the user is saved in the flash memory of XGB main unit after download.

#### (2) How to use [I/O Parameter]

- (a) Execute the XG5000 and make the project.  
(For how to make the project, refer to the XG5000 user manual)
- (b) Double-click [I/O Parameter] on the project window.

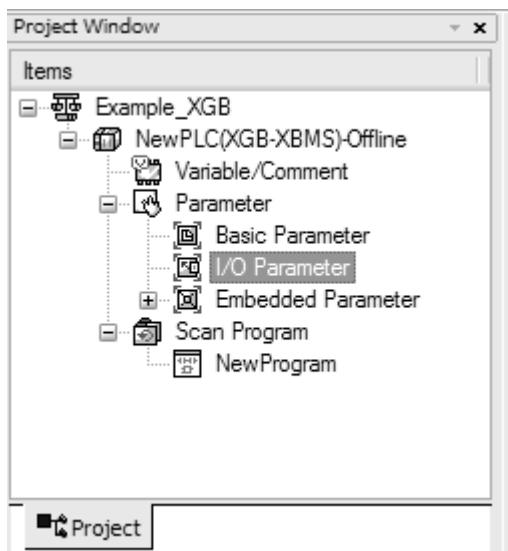

(c) If [I/O Parameter Setting] window shows, find slot of base where module is installed and click it.

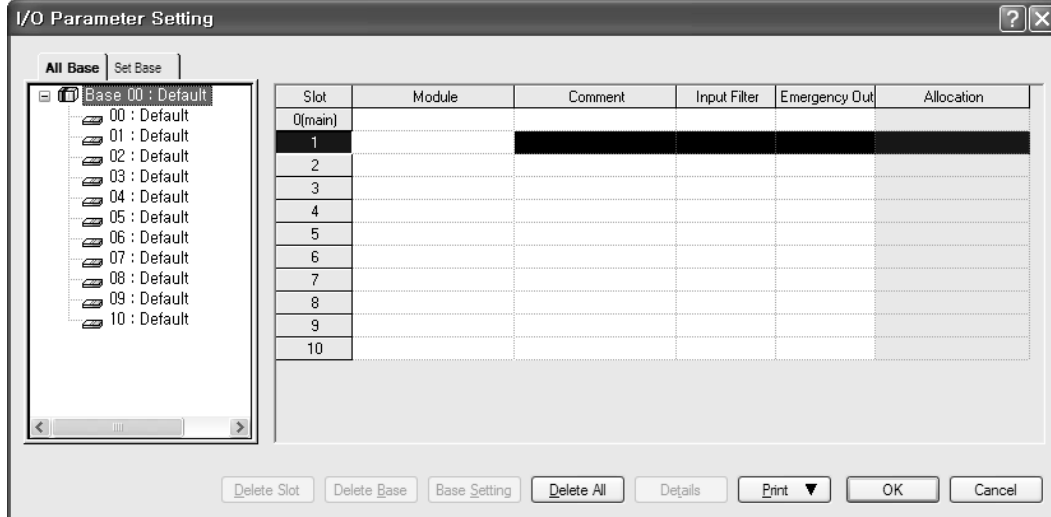

(d) Register the module on a slot where module is installed on as follows.

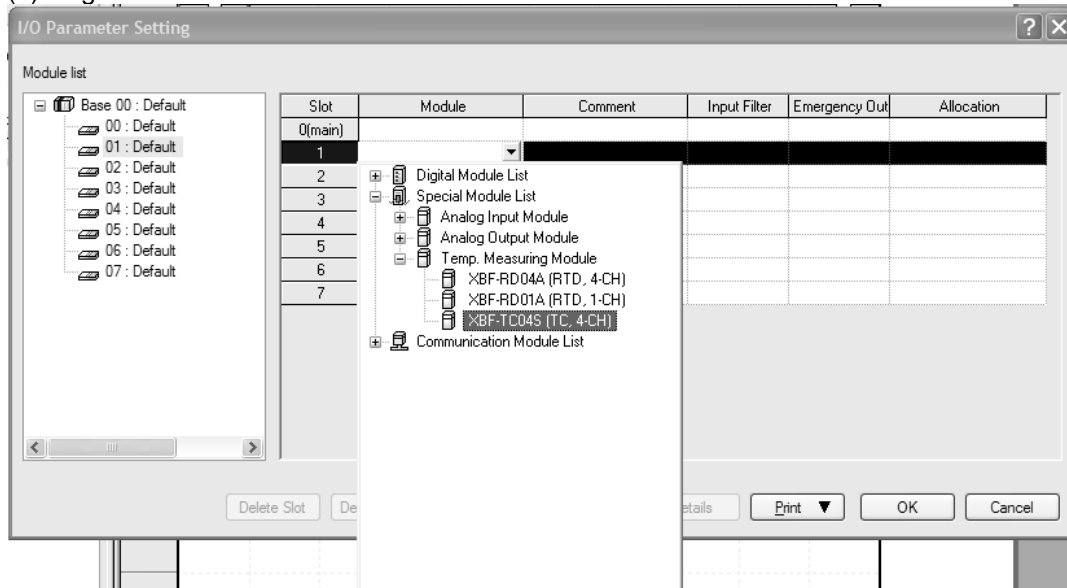

(e) Select a module registered and click [Details] or double-click a module

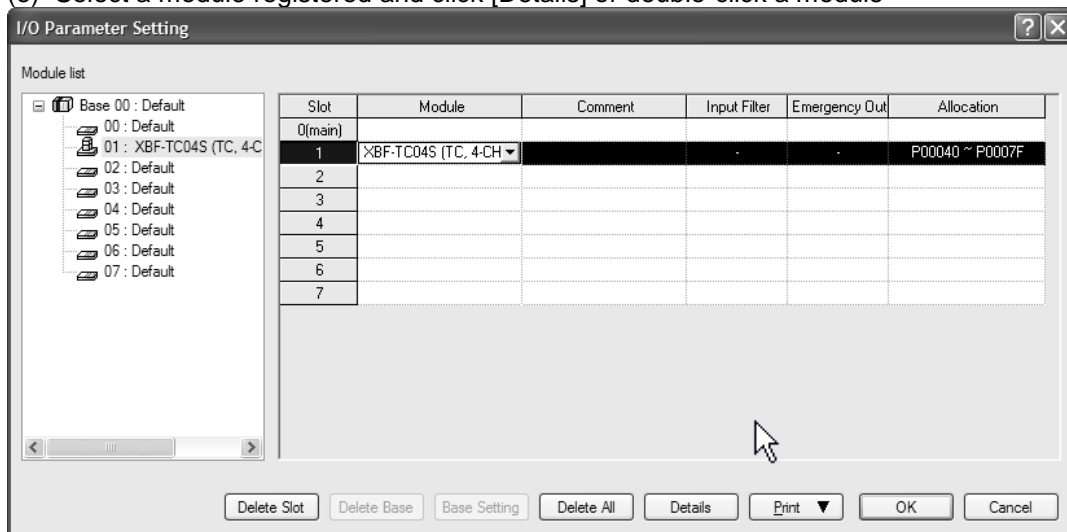

(f) Select the required settings in Parameter Settings and click [OK].

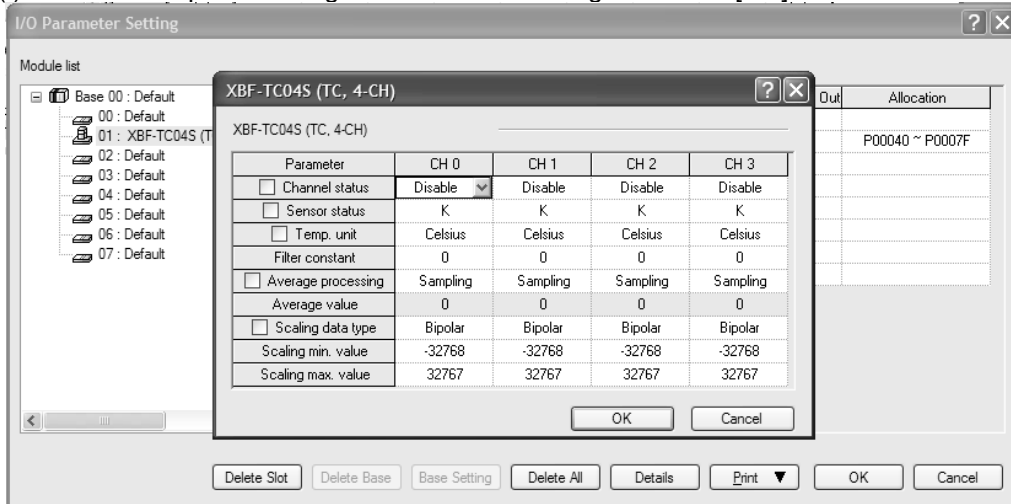

(g) The initial values of each item are as figure shown below

1) Channel status (Disable / Enable)

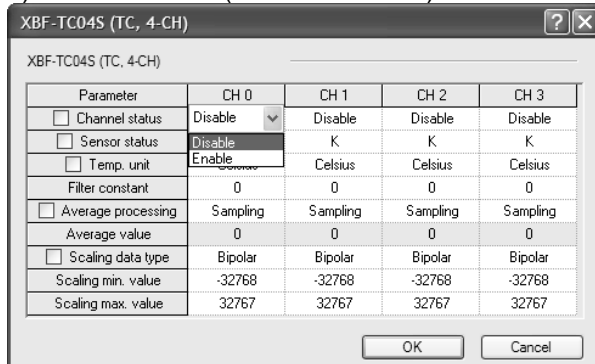

2) Sensor status (K / J / T / R)

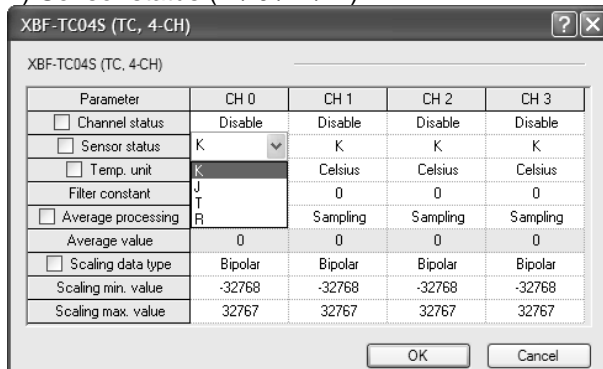

3) Temp. unit (Celsius / Fahrenheit)

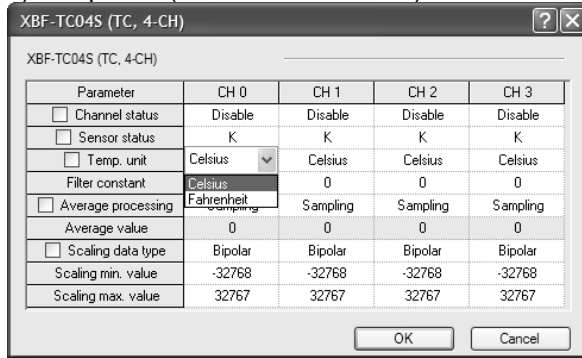

4) Filter constant (0, 200 ~ 64000)

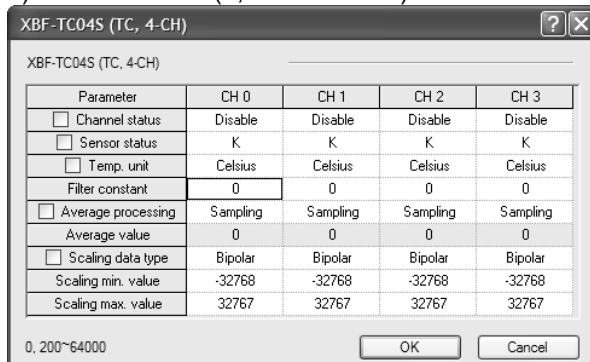

5) Average processing (Sampling / Time-Avr / Count-Avr / Moving-Avr)

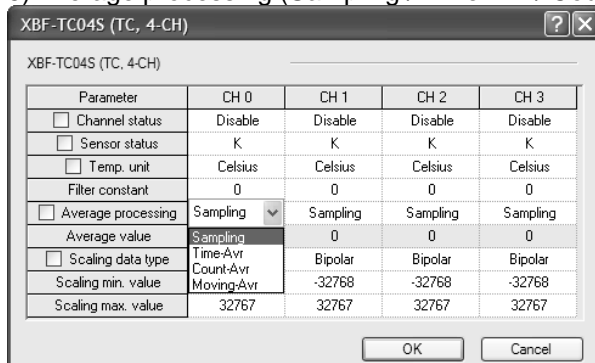

6) Scaling data type (Bipolar / Unipolar)

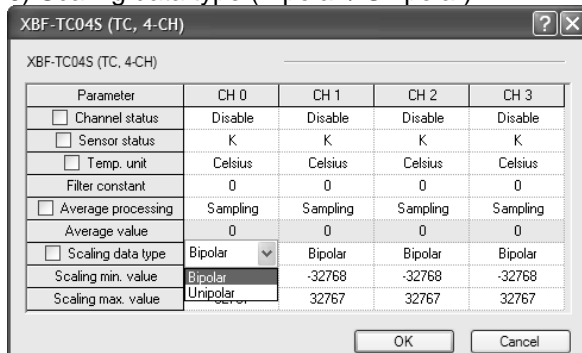

7) Scaling min. value/scaling max. value

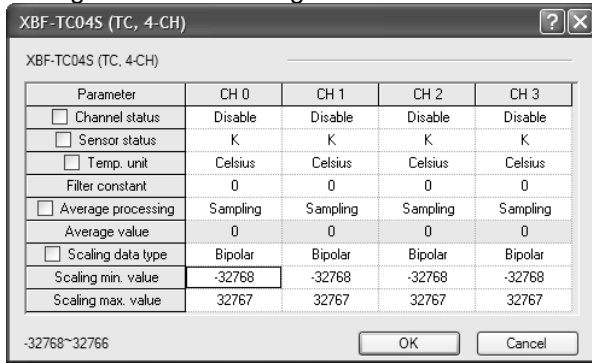

Scaling data type	Scaling min value	Scaling max value
With sign	-32768 ~ [scaling max value -1]	[scaling min value+1] ~ 32767
Without sign	0 ~ [scaling max value -1]	[scaling min value+1] ~ 65535

(h) Constant input

- 1) In case the user inputs numbers directly like filter constant, if the relevant parameter is selected, available range is displayed in the bottom.

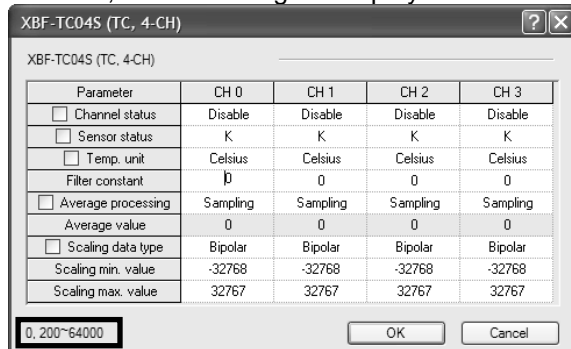

- 2) If the number is out of range, error message is displayed. (If error information shows, it returns to previous status. Set again.)

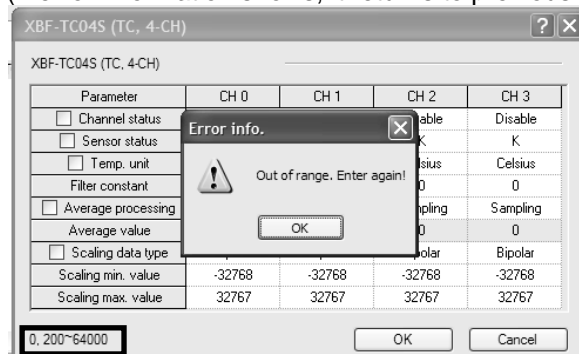

- 3) If the wrong number is specified, it is displayed with red color.  
(When Average value or scaling min./max. value is out of range.)

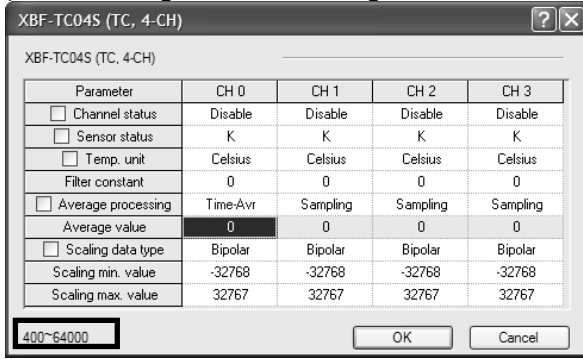

### 5.5.2 Special module monitoring function

While XG5000 is connected with PLC, through [Monitor] -> [Special Module Monitoring], the user can test the operation of the analog output module.

#### Remark

- 1) If system resource is short, the screen may not be displayed properly. In case of this, shut down other application program and restart the XG5000.
- 2) On the [Special Module Monitoring] status, I/O parameter is set temporarily to execute the test. So if [Special Module Monitoring] status ends, I/O parameter is not saved.
- 3) By test function of [Special Module Monitoring], the user can check if analog module operates properly or not without any sequence program.

#### (1) How to use special module monitoring

##### (a) Start of [Special Module Monitoring]

While XG5000 is connected with PLC, start [Monitor] -> [Special Module Monitoring]. If that is not online status, [Special Module Monitoring] is not activated.

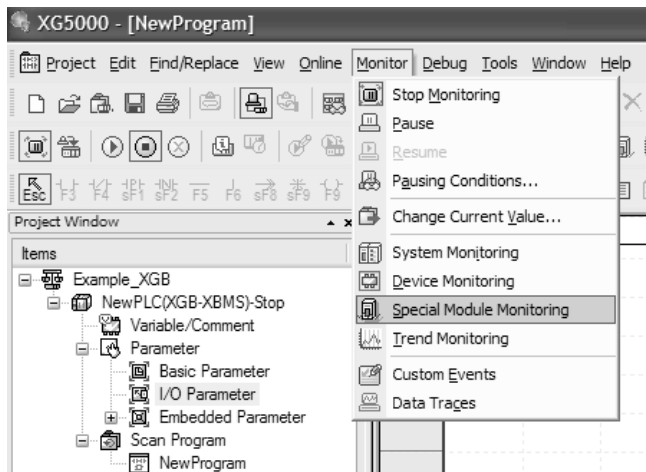

(b) How to use [Special Module Monitoring]

- 1) Click [Monitor] -> [Special Module Monitoring] while XG5000 is connected with PLC basic unit. 'Special Module List' screen is displayed as shown below and displays information of base/slot with special module type. On the list dialog box, The modules currently equipped at the PLC are displayed.

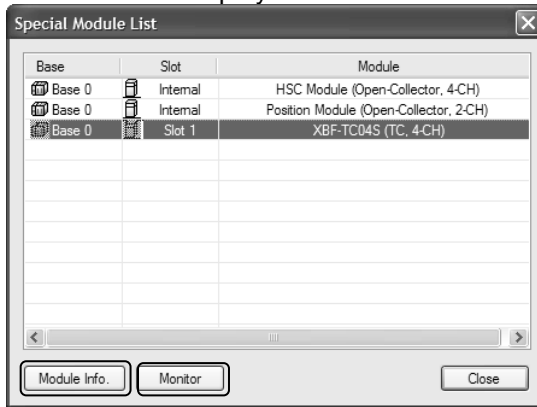

- 2) Clicking [Module Info.] shows the information of special module.

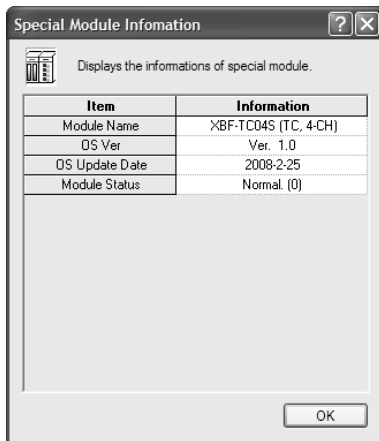

- 3) Clicking [Monitor] shows the following screen.

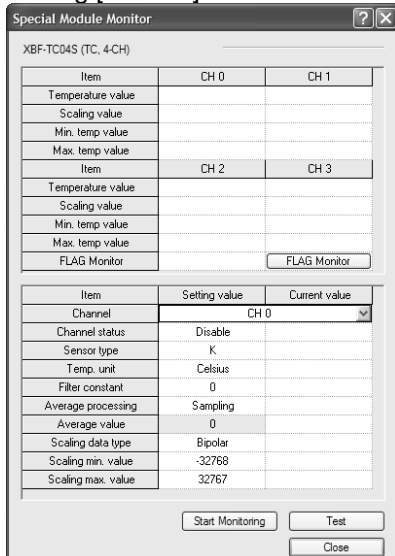

- 4) [Start Monitoring]: [Start Monitoring] button will show you digital input data of the operating channel. The figure below is monitoring screen when all channels are Run status.

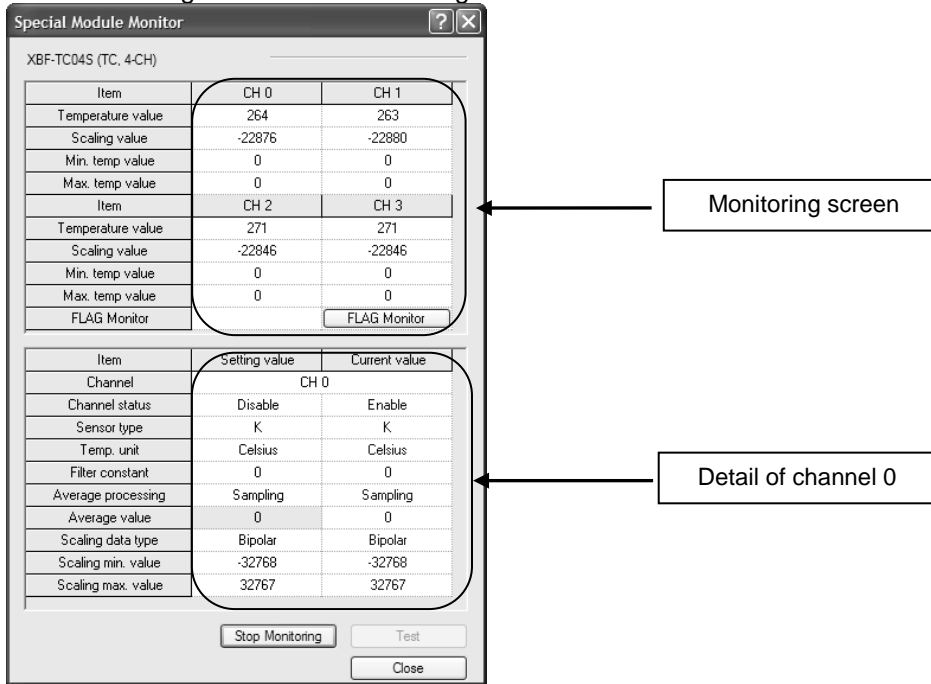

[Start Monitoring] execution screen

- 5) [Test]: [Test] is used to change the parameters of the Thermocouple input module. You can change the parameters when you click the values at the bottom of the screen. It is only available when XGB CPU unit's status is in [Stop].

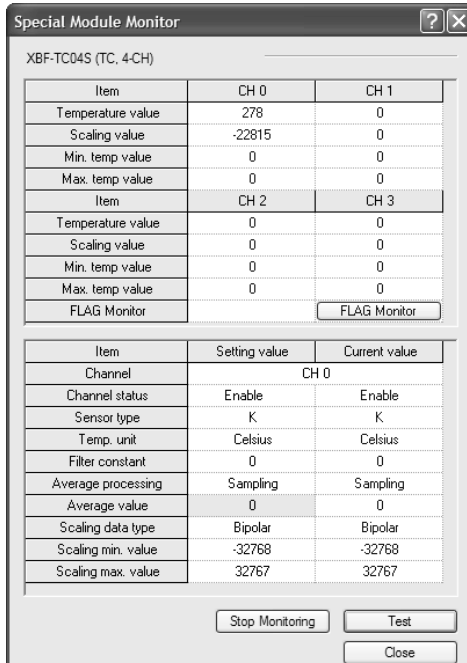

[Test] execution screen



- 6) If [Flag Monitor] is selected on the [Special Module Monitor] window, [Temp. Measuring Module Command] screen can be monitored.

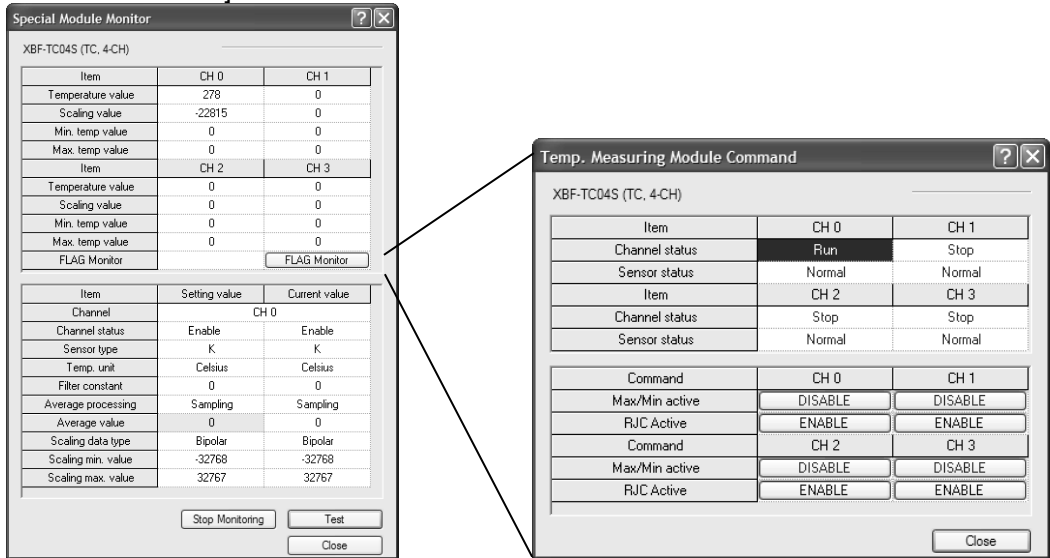

[Temp. Measuring Module Command] execution screen

- 7) [Temp. Measuring Module Command] screen  
 On the monitoring screen, Channel status (Run/Stop) and Sensor status (Normal/Disconnection) can be monitored.  
 On the flag command screen, Max/Min active (ENABLE/DISABLE) and cold junction compensation (ENABLE/DISABLE) can be specified.

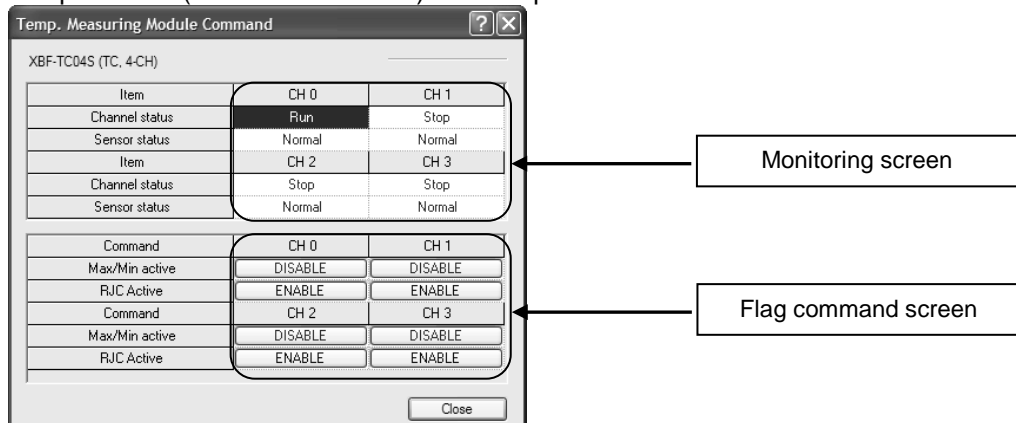

- 8) [Close]: [Close] is used to escape from the monitoring/test screen. When the monitoring/test screen is closed, the max. value, the min. value and the present value will not be saved any more.

**Remark**

[Test] function is only available when XGB CPU unit's status is in [Stop].

### 5.5.3 Register U devices (Special module variable)

Register the variables for each module referring to the special module information that is set in the I/O parameter. The user can modify the variables and comments.

(1) Procedure

(a) Select the special module type in the [I/O Parameter Setting] window.

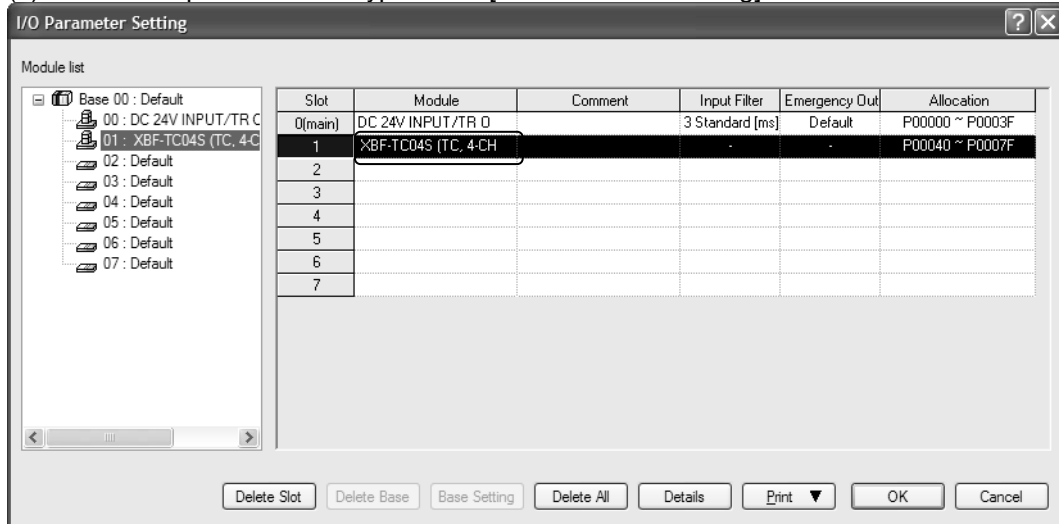

(b) Double click 'Variable/Comment' from the project window.

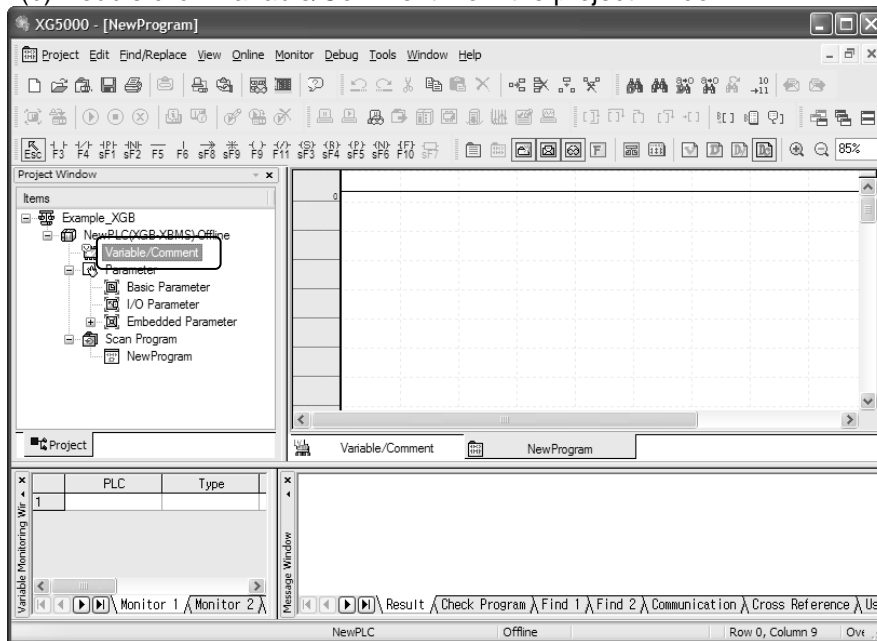

- (c) Select [Edit] – [Register U Device].  
In case of XEC, select [Edit] - [Register special module variable]

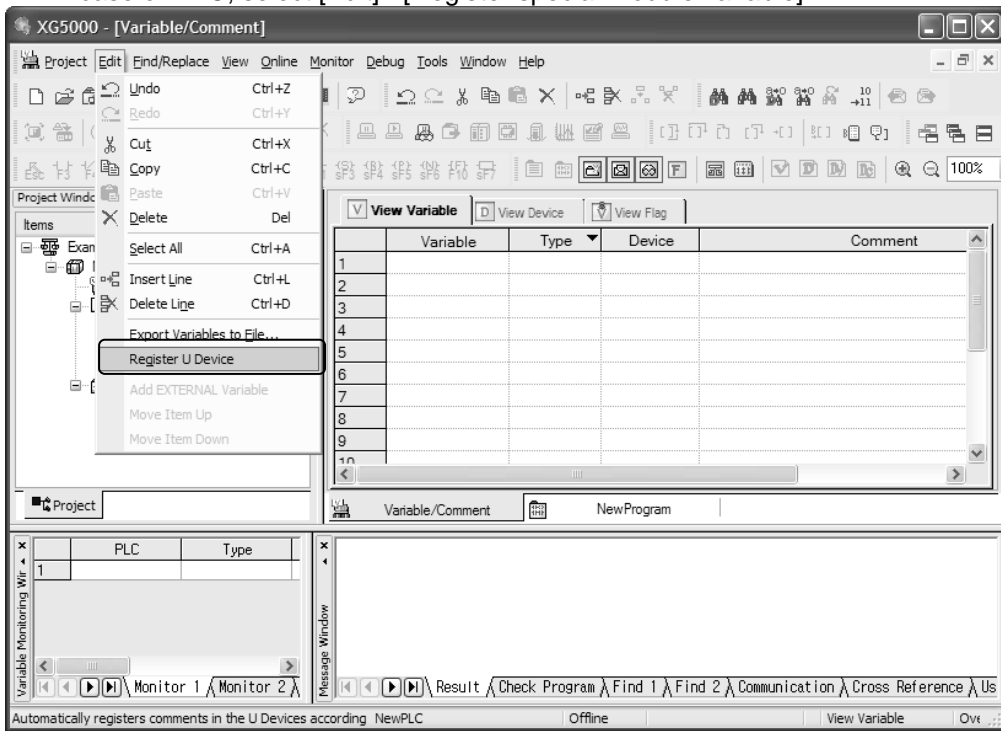

(d) Click 'Yes'. The previous comment will be deleted.

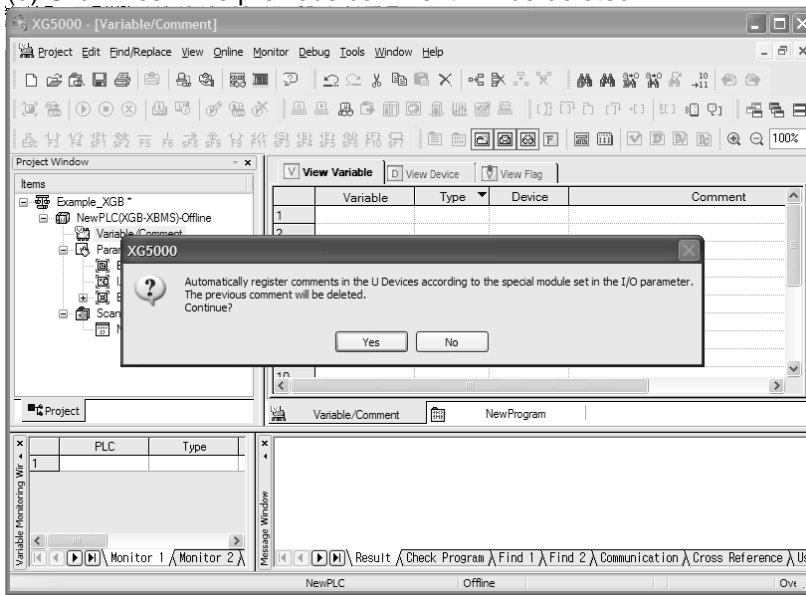

(e) As shown below, the variables are registered.

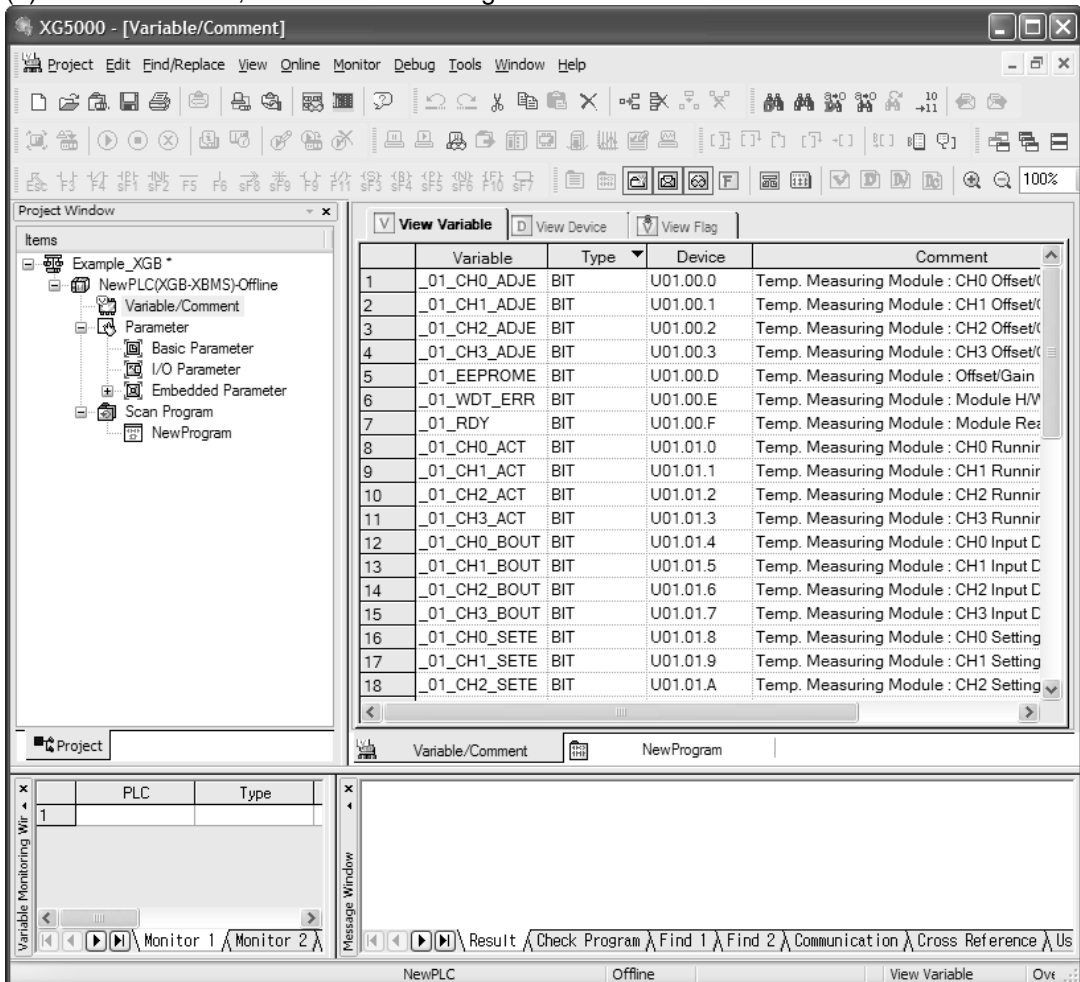

(2) Save variables

- (a) The contents of 'View Variable' can be saved as a text file.
- (b) Select [Edit] -> [Export to File].
- (c) The contents of 'View variable' are saved as a text file.

(3) View variables

- (a) The example program of XG5000 is as shown below.

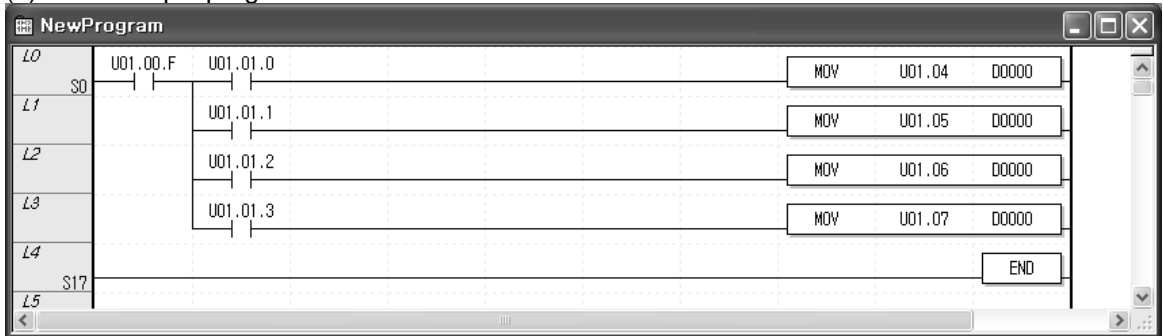

- (b) Select [View] -> [Variables]. The devices are changed into variables.

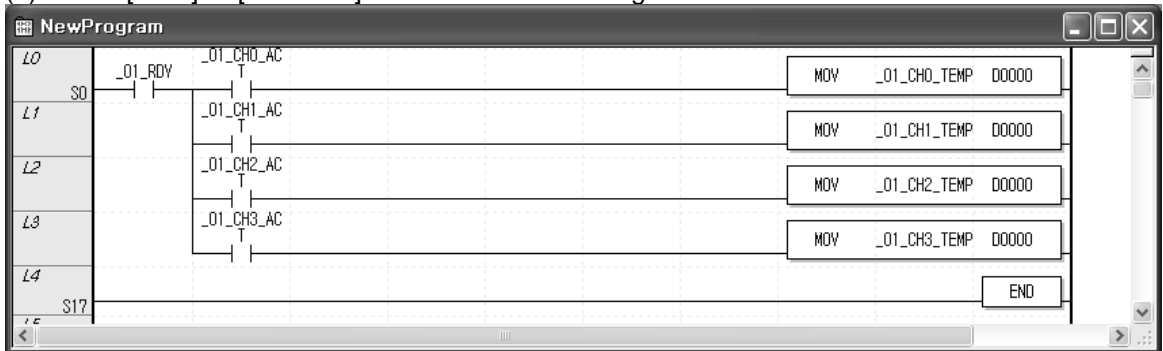

- (c) Select [View] -> [Devices/Variables]. Devices and variables are both displayed.

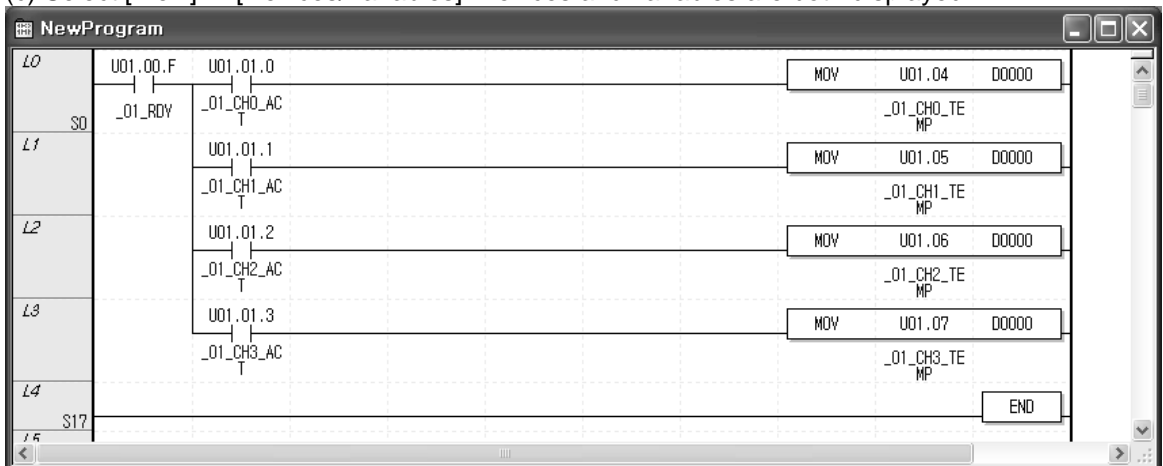

(d) Select [View] -> [Device/Comments]. Devices and comments are both displayed.

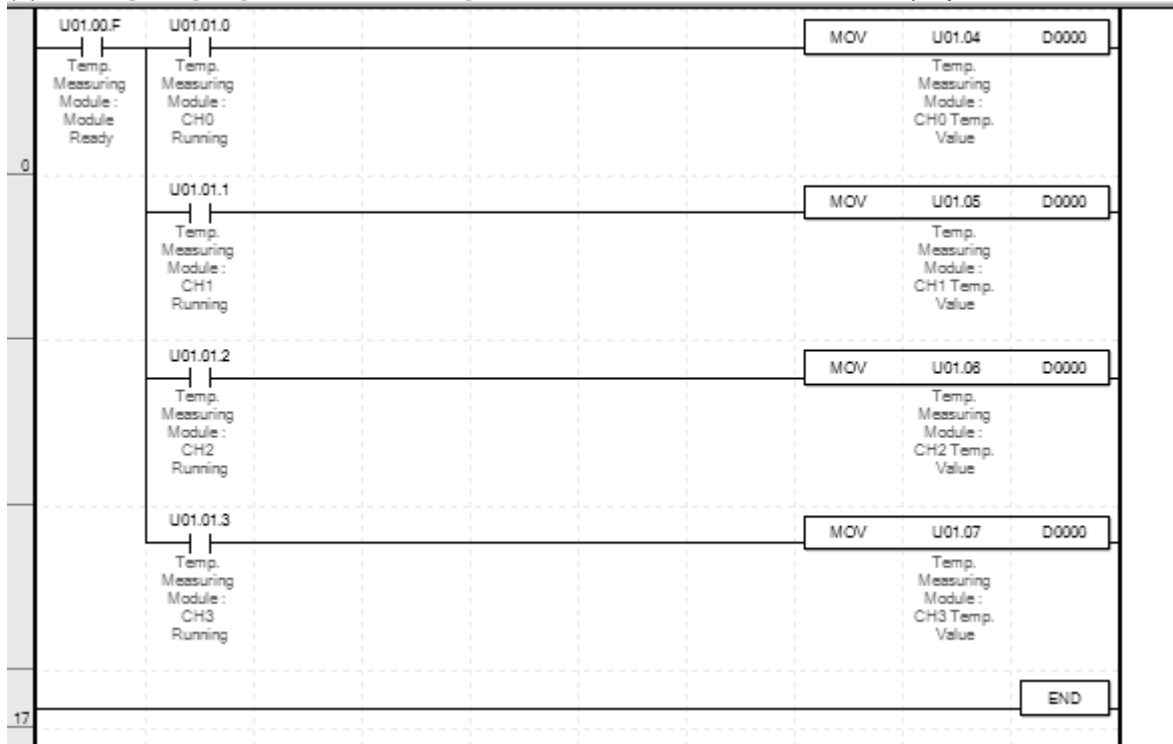

## 5.6 Configuration and Function of Internal Memory

It describes the configuration and function of internal memory.

### 5.6.1 Data I/O area (U device)

(1) Data sent from module to XGB main unit (XGB PLC input area, read only)

Device assignment	Type	Comment	Content	R/W	Signal direction
U0x.00.0	BIT	CH 0 offset/gain adjustment error	On: error, Off: normal	R	TC→CPU
U0x.00.1	BIT	CH 1 offset/gain adjustment error		R	
U0x.00.2	BIT	CH 2 offset/gain adjustment error		R	
U0x.00.3	BIT	CH 3 offset/gain adjustment error		R	
U0x.00.D	BIT	Module offset/gain backup error		R	
U0x.00.E	BIT	Module H/W error		R	
U0x.00.F	BIT	Module Ready	On: ready Off: not ready	R	
U0x.01.0	BIT	CH 0 running	Channel running On: run, Off: stop	R	TC→CPU
U0x.01.1	BIT	CH 1 running		R	
U0x.01.2	BIT	CH 2 running		R	
U0x.01.3	BIT	CH 3 running		R	
U0x.01.4	BIT	CH 0 disconnection	Thermocouple sensor On: disconnection, Off: normal	R	
U0x.01.5	BIT	CH 1 disconnection		R	
U0x.01.6	BIT	CH 2 disconnection		R	
U0x.01.7	BIT	CH 3 disconnection		R	
U0x.01.8	BIT	CH 0 setting error	Parameter setting On: setting error Off: setting normal	R	
U0x.01.9	BIT	CH 1 setting error		R	
U0x.01.A	BIT	CH 2 setting error		R	
U0x.01.B	BIT	CH 3 setting error		R	
U0x.04	WORD	CH 0 temp. conversion value	Temp. conversion value (Measured temp.x10)	R	TC→CPU
U0x.05	WORD	CH 1 temp. conversion value		R	
U0x.06	WORD	CH 2 temp. conversion value		R	
U0x.07	WORD	CH 3 temp. conversion value		R	
U0x.08	WORD	CH 0 scaling operation value	Range with sign: -32768~32767 Range without sign: 0~65535	R	TC→CPU
U0x.09	WORD	CH 1 scaling operation value		R	
U0x.10	WORD	CH 2 scaling operation value		R	
U0x.11	WORD	CH 3 scaling operation value		R	
U0x.12	WORD	CH 0 min. temp. conversion value	Temp. conversion min./max. accumulation	R	TC→CPU
U0x.13	WORD	CH 0 max. temp. conversion value		R	
U0x.14	WORD	CH 1 min. temp. conversion value		R	
U0x.15	WORD	CH 1 max. temp. conversion value		R	
U0x.16	WORD	CH 2 min. temp. conversion value		R	
U0x.17	WORD	CH 2 max. temp. conversion value		R	
U0x.18	WORD	CH 3 min. temp. conversion value		R	
U0x.19	WORD	CH 3 max. temp. conversion value		R	

※ 'x' means slot no. where module is installed.

Ex.) U02.04: no.2 slot channel 0 temp. conversion value (word)

## Chapter 5 Thermocouple Input (XBF-TC04S/TC04B)

(2) Command sent from XGB main unit to module (XGB PLC output area, read/write available)

Device assignment	Type	Comment	Content	R/W	Signal direction
U0x.29.0	BIT	CH 0 max./min. searching Enable/Disable	Min./max. search On: enable Off: disable	R/W	CPU↔TC
U0x.29.1	BIT	CH 1 max./min. searching Enable/Disable		R/W	
U0x.29.2	BIT	CH 2 max./min. searching Enable/Disable		R/W	
U0x.29.3	BIT	CH 3 max./min. searching Enable/Disable		R/W	
U0x.29.8	BIT	CH 0 cold junction compensation Enable/Disable	Cold junction compensation On: enable Off: disable	R/W	
U0x.29.9	BIT	CH 1 cold junction compensation Enable/Disable		R/W	
U0x.29.A	BIT	CH 2 cold junction compensation Enable/Disable		R/W	
U0x.29.B	BIT	CH 3 cold junction compensation Enable/Disable		R/W	

※ 'x' means slot no. where module is installed.

Ex.) U03.29.02: no.3 slot, CH 2 max./min. searching Enable/Disable (bit)



(3) Data sent from module to XGB main unit (IEC type)  
(XGB PLC input area, read only)

Device assignment	Type	Comment	Content	R/W	Signal direction
%UX0.x.0	BIT	CH 0 offset/gain adjustment error	On: error Off: normal	R	TC→CPU
%UX0.x.1	BIT	CH 1 offset/gain adjustment error		R	
%UX0.x.2	BIT	CH 2 offset/gain adjustment error		R	
%UX0.x.3	BIT	CH 3 offset/gain adjustment error		R	
%UX0.x.13	BIT	Module offset/gain backup error		R	
%UX0.x.14	BIT	Module H/W error		R	
%UX0.x.15	BIT	Module Ready	On: ready Off: not ready	R	TC→CPU
%UX0.x.16	BIT	CH 0 running	Channel running On: run, Off: stop	R	
%UX0.x.17	BIT	CH 1 running		R	
%UX0.x.18	BIT	CH 2 running		R	
%UX0.x.19	BIT	CH 3 running		R	
%UX0.x.20	BIT	CH 0 disconnection	Thermocouple sensor On: disconnection, Off: normal	R	
%UX0.x.21	BIT	CH 1 disconnection		R	
%UX0.x.22	BIT	CH 2 disconnection		R	
%UX0.x.23	BIT	CH 3 disconnection		R	
%UX0.x.24	BIT	CH 0 setting error	Parameter setting On: setting error Off: setting normal	R	
%UX0.x.25	BIT	CH 1 setting error		R	
%UX0.x.26	BIT	CH 2 setting error		R	
%UX0.x.27	BIT	CH 3 setting error		R	
%UW0.x.4	WORD	CH 0 temp. conversion value	Temp. conversion value (Measured temp.x10)	R	TC→CPU
%UW0.x.5	WORD	CH 1 temp. conversion value		R	
%UW0.x.6	WORD	CH 2 temp. conversion value		R	
%UW0.x.7	WORD	CH 3 temp. conversion value		R	
%UW0.x.8	WORD	CH 0 scaling operation value	Range with sign: -32768~32767 Range without sign: 0~65535	R	TC→CPU
%UW0.x.9	WORD	CH 1 scaling operation value		R	
%UW0.x.10	WORD	CH 2 scaling operation value		R	
%UW0.x.11	WORD	CH 3 scaling operation value		R	
%UW0.x.12	WORD	CH 0 min. temp. conversion value	Temp. conversion min./max. accumulation	R	TC→CPU
%UW0.x.13	WORD	CH 0 max. temp. conversion value		R	
%UW0.x.14	WORD	CH 1 min. temp. conversion value		R	
%UW0.x.15	WORD	CH 1 max. temp. conversion value		R	
%UW0.x.16	WORD	CH 2 min. temp. conversion value		R	
%UW0.x.17	WORD	CH 2 max. temp. conversion value		R	
%UW0.x.18	WORD	CH 3 min. temp. conversion value		R	
%UW0.x.19	WORD	CH 3 max. temp. conversion value		R	

※ 'x' means slot no. where module is installed.

Ex.) %UW0.2.4: no.2 slot channel 0 temp. conversion value (word)

(4) Command sent from XGB main unit (IEC type) to module  
(XGB PLC output area, read/write available)

Device assignment	Type	Comment	Content	R/W	Signal direction
%UX0.x.464	BIT	CH 0 max./min. searching Enable/Disable	Min./max. search On: enable Off: disable	R/W	CPU↔TC
%UX0.x.465	BIT	CH 1 max./min. searching Enable/Disable		R/W	
%UX0.x.466	BIT	CH 2 max./min. searching Enable/Disable		R/W	
%UX0.x.467	BIT	CH 3 max./min. searching Enable/Disable		R/W	
%UX0.x.472	BIT	CH 0 cold junction compensation Enable/Disable	Cold junction compensation On: enable Off: disable	R/W	
%UX0.x.473	BIT	CH 1 cold junction compensation Enable/Disable		R/W	
%UX0.x.474	BIT	CH 2 cold junction compensation Enable/Disable		R/W	
%UX0.x.475	BIT	CH 3 cold junction compensation Enable/Disable		R/W	

※ 'x' means slot no. where module is installed.  
Ex.) %UX0.3.466: no.3 slot, CH 2 max./min. searching Enable/Disable (bit)

### 5.6.2 How to set operation parameter

Operation parameter of thermocouple input module can be set by two methods.

(1) Setting operation parameters through [I/O parameter setting] window.

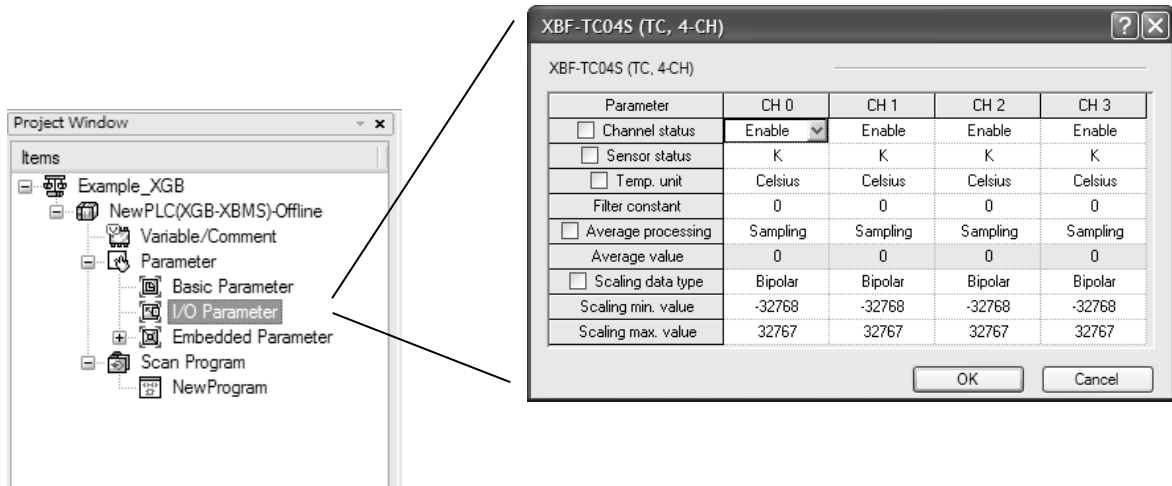

(2) Writing operation parameters through program (PUT instruction is used.)

0	U01.00.F	M0000	PUT	1	0	D0000	1	h0001: Ch0 running h0002: Ch1 running h0003: Ch2 running h0004: Ch3 running
		M0001	PUT	1	0	h0000	1	All channels stop
		M0002	PUT	1	0	h000F	1	All channels run
		M0003	PUT	1	1	h0000	1	Ch0 K type sensor
		M0004	PUT	1	5	h0000	1	Celsius
		M0005	PUT	1	10	h0001	1	Enable Ch0 time - Avr
		M0006	PUT	1	14	400	1	Time-Avr value: 400ms
		M0007	PUT	1	18	h0000	1	Bipolar
		M0008	PUT	1	19	0	1	Ch0 scaling min. value
		M0009	PUT	1	20	0	1	Ch.0 scaling max. value
71							END	

**Remark**

How to use PUT instruction

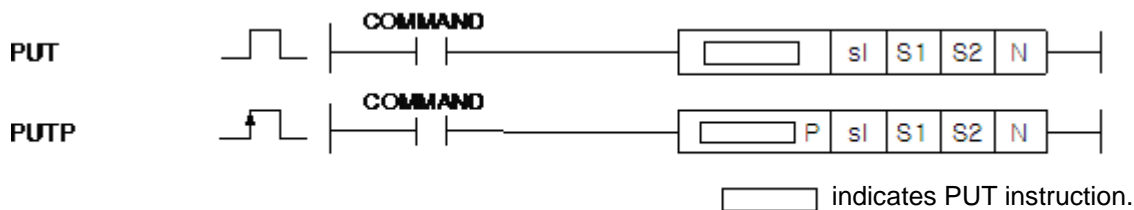

[Area setting]

Operand	Description	Data size
sl	Slot no. where special module is mounted	WORD
S1	Internal memory address of special module	WORD
S2	Device to save in special module	WORD
N	The number of data	WORD

(3) Writing operation parameters at setting area of thermocouple input module through program (IEC type, PUT function block is used)

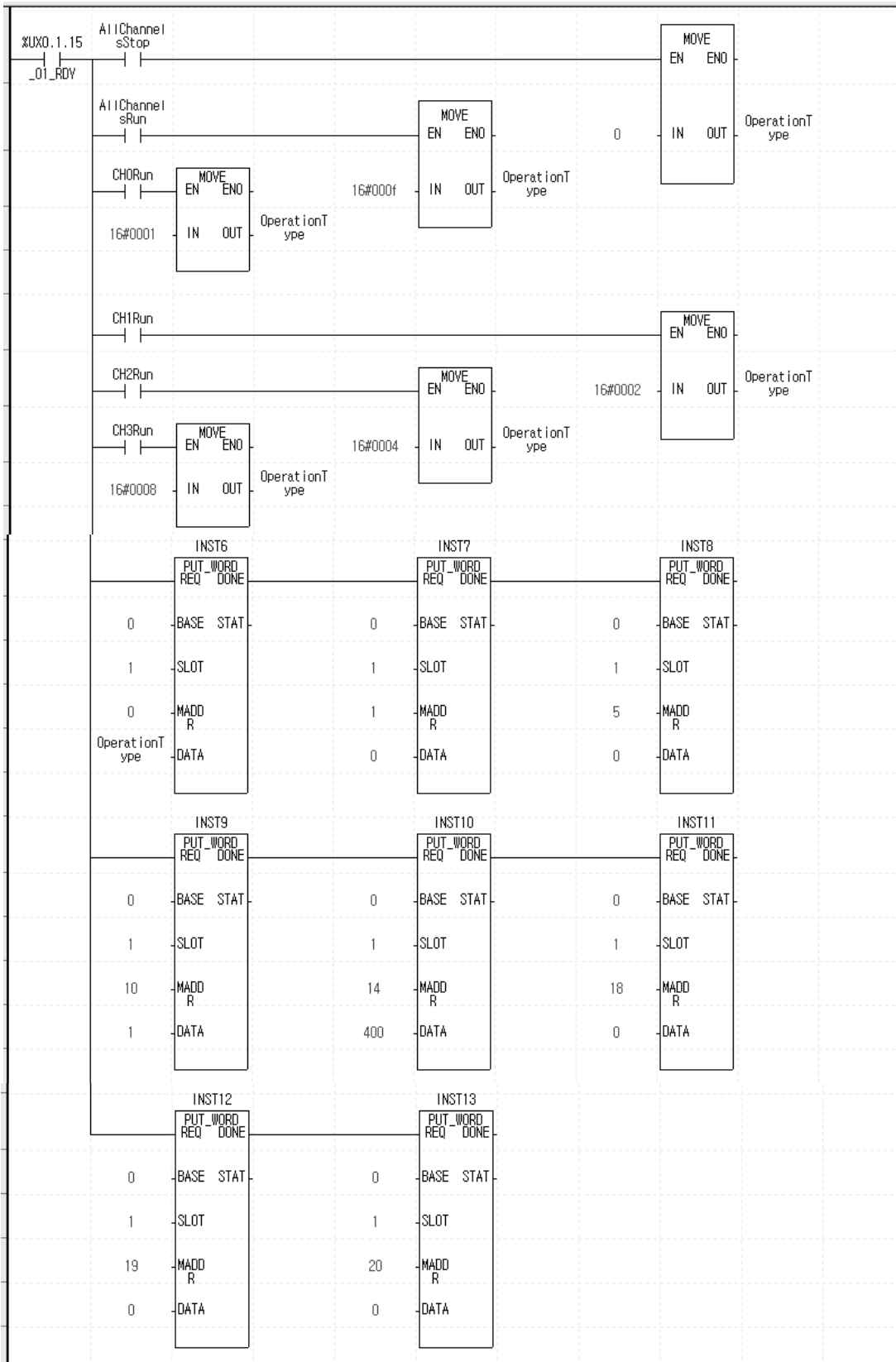

## 5.6.3 Operation parameter setting area

It describes operation parameter setting area of thermocouple input module.

Memory address		Description	Setting value	R/W	Instruction
Hex.	Dec.				
00 <sub>H</sub>	0	Designate a channel to use	bit0:bit3, 0: stop, 1: run	R/W	PUT/GET
01 <sub>H</sub>	1	Set sensor type of CH 0	K:0, J:1, T:2, R:3 0~100 mV:4 (XBF-TC04B)	R/W	
02 <sub>H</sub>	2	Set sensor type of CH 1			
03 <sub>H</sub>	3	Set sensor type of CH 2			
04 <sub>H</sub>	4	Set sensor type of CH 3			
05 <sub>H</sub>	5	Designate temperature metric system	bit0:bit3, 0: Celsius, 1: Fahrenheit	R/W	
06 <sub>H</sub>	6	Set CH 0 filter value	0 or 200 ~ 64000	R/W	
07 <sub>H</sub>	7	Set CH 1 filter value			
08 <sub>H</sub>	8	Set CH 2 filter value			
09 <sub>H</sub>	9	Set CH 3 filter value			
0A <sub>H</sub>	10	Set averaging method of CH 0	0: sampling 1: time average 2: count average 3: moving average	R/W	
0B <sub>H</sub>	11	Set averaging method of CH 1			
0C <sub>H</sub>	12	Set averaging method of CH 2			
0D <sub>H</sub>	13	Set averaging method of CH 3			
0E <sub>H</sub>	14	Set mean value of CH 0	Time average: 400~60000 ms Count average: 2~64000 times Moving average: 2~100	R/W	
0F <sub>H</sub>	15	Set mean value of CH 1			
10 <sub>H</sub>	16	Set mean value of CH 2			
11 <sub>H</sub>	17	Set mean value of CH 3			
12 <sub>H</sub>	18	Designate scaling type	bit0:bit3, 0: signed, 1: unsigned	R/W	
13 <sub>H</sub>	19	Set min. value of CH 0 scaling range	Min. value signed: -32768~[max.-1] unsigned: 0~[max.-1]  Max. value signed: [Min.+1]~32767 Unsigned: [Min.+1]~65535	R/W	
14 <sub>H</sub>	20	Set max. value of CH 0 scaling range			
15 <sub>H</sub>	21	Set min. value of CH 1 scaling range			
16 <sub>H</sub>	22	Set max. value of CH 1 scaling range			
17 <sub>H</sub>	23	Set min. value of CH 2 scaling range			
18 <sub>H</sub>	24	Set max. value of CH 2 scaling range			
19 <sub>H</sub>	25	Set min. value of CH 3 scaling range			
1A <sub>H</sub>	26	Set max. value of CH 3 scaling range			
1B <sub>H</sub>	27	Set error inf. Of CH0.	Setting error information (Flag)	R	GET

## Chapter 5 Thermocouple Input (XBF-TC04S/TC04B)

Memory address		Description	Setting value	R/W	Instruction
Hex.	Dec.				
1C <sub>H</sub>	28	Set error inf. Of CH1			
1D <sub>H</sub>	29	Set error inf. Of CH2			
1E <sub>H</sub>	30	Set error inf. Of CH3			
1F <sub>H</sub>	31	Cold junction compensation temp. of CH0.	Measured value of cold junction compensation temp.	R	GET
20 <sub>H</sub>	32	Cold junction compensation temp. of CH1.			
21 <sub>H</sub>	33	Cold junction compensation temp. of CH2.			
22 <sub>H</sub>	34	Cold junction compensation temp. of CH3.			
23 <sub>H</sub> ~3F <sub>H</sub>	35 ~63	System area (Offset gain storage area)	Read/Write unavailable	unavailable	-



### Caution

- (1) If input value of memory address 00<sub>H</sub>~1A<sub>H</sub>(0~26) is out of range of setting value, U0x.01.8~U0x.01.B (setting error representation flag, in case of IEC type, %UX0.x.24~%UX0.x.27) are on and it acts as default setting value. Error information is displayed in 1B<sub>H</sub>~1F<sub>H</sub>(27~30) area.
- (2) System area (Offset gain storage area) is area where Read/Write is unavailable. If this area changes, malfunction or breakdown may occur.

(1) Designating Channel (Address 0)

- (a) Temperature conversion module Enable/Disable can be set to each channel.
- (b) By prohibiting a channel not to use from conversion, conversion interval by channels can be shortened.
- (c) If channel to use is not designated, every channel can not be used.
- (d) In case of using PUT instruction, temperature conversion module Enable/Disable are as follows.

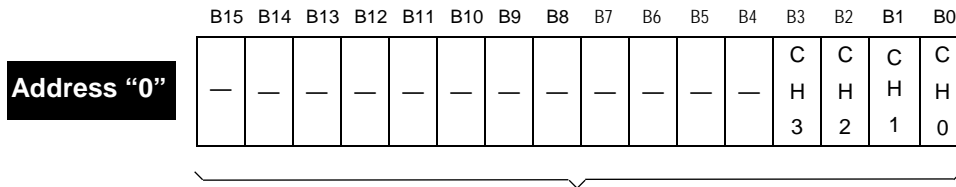

BIT	Description
0	Stop
1	Operate

- (e) Vales set in B4 ~ B15 are ignored.
- (f) This area shows the same results with operation channel designation in I/O parameter setting window.

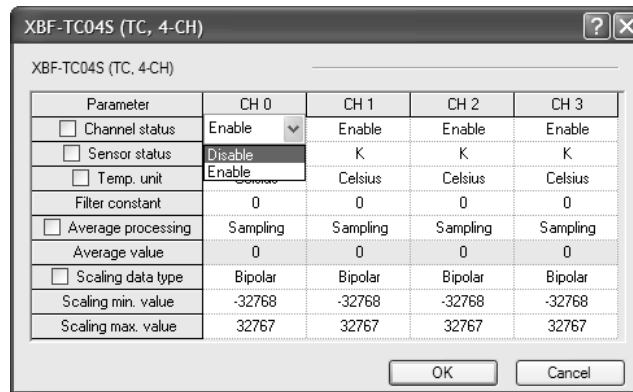

(2) Sensor Type Setting Area (Address 1~4)

- (a) Thermocouple sensor type can be set per channel.
- (b) In case of using PUT instruction, Sensor Type Setting Area is as follows.

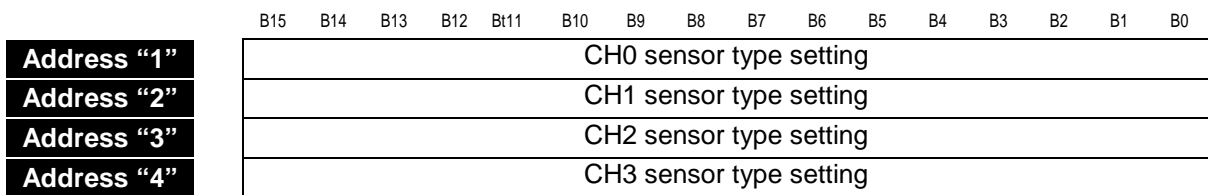

Word	Description
0	K type
1	J type
2	T type
3	R type
4	0~100mV (XBF-TC04B)

- (c) When input value is larger than 4, 0 (K type) is selected by force.  
But, U0x.01.8~ U0x.01.B (setting error representation, in case of IEC type, %UX0.x.24 ~ %UX0.x.27) are on, error information is displayed at bit 0 of address 27~30.

(d) This area shows the same results with sensor type designation in I/O parameter setting window.

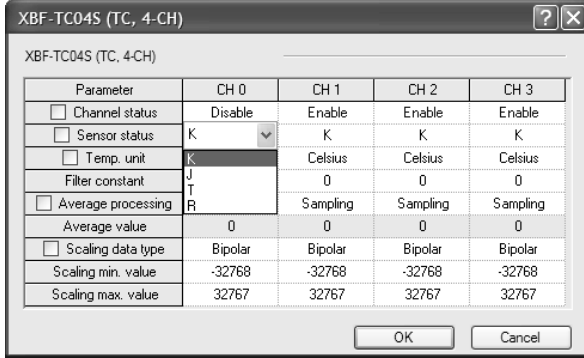

(3) Temp. unit setting area (Address 5)

- (a) Temp. unit (Celsius/ Fahrenheit) of thermocouple input module can be set per channel.
- (b) In case of PUT instruction, Temp. unit setting area is as follows.

**Address "5"**

B15	B14	B13	B12	B11	B10	B9	B8	B7	B6	B5	B4	B3	B2	B1	B0
—	—	—	—	—	—	—	—	—	—	—	—	C	C	C	C
												H	H	H	H
												3	2	1	0

Bit	Description
0	Celsius
1	Fahrenheit

(c) Values set in B4 ~ B15 are ignored.

(d) This area shows the same results with temp. unit setting in I/O parameter setting window.

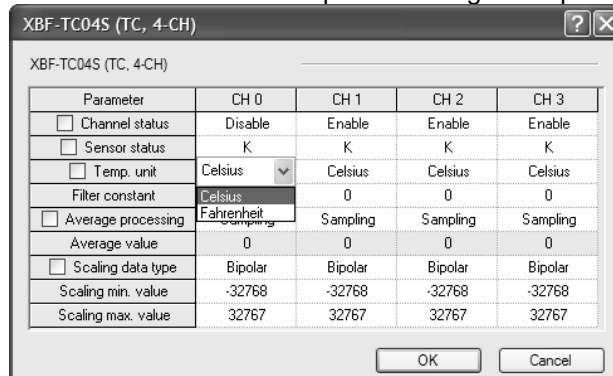

(4) Filter constant setting area (Address 6~9)

- (a) Filter constant can be set per channel.
- (b) Filter constant ranges 0 or 200 ~ 64000.
- (c) If filter constant is set as 0, filtering process is not executed.
- (d) When input is 1~199 or larger than 6400, 0 (filter disable) is selected by force.  
But, U0x.01.8~ U0x.01.B (setting error representation, in case of IEC type, %UX0.x.24 ~ %UX0.x.27) are on, error information is displayed at bit 1 of address 27~30.
- (e) In case of PUT instruction, filter constant setting address is as follows.



<b>Address "6"</b>	B15 B14 B13 B12 B11 B10 B9 B8 B7 B6 B5 B4 B3 B2 B1 B0	CH0 filter constant setting (0, 200~64000)
<b>Address "7"</b>		CH1 filter constant setting (0, 200~64000)
<b>Address "8"</b>		CH2 filter constant setting (0, 200~64000)
<b>Address "9"</b>		CH3 filter constant setting (0, 200~64000)

(f) This area shows the same results with filter constant setting in I/O parameter setting window.

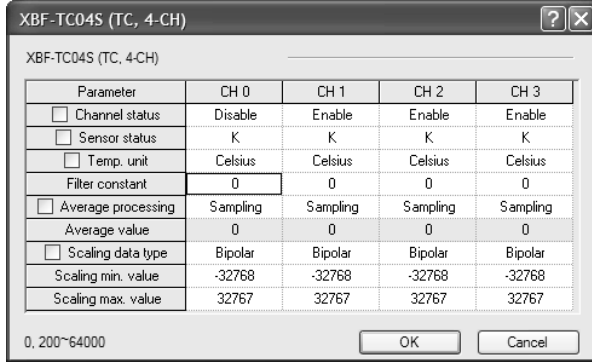

(5) Average processing setting area (Address 10~13)

- (a) Average processing method can be set per channel.
- (b) Average processing method (Sampling: 0 / time-avr.: 1 / count-avr.: 2 / moving-avr.: 3)
- (c) When input is larger than 4, 0 (sampling) is set by force.  
But, U0x.01.8~ U0x.01.B (setting error representation, in case of IEC type, %UX0.x.24~%UX0.x.27) are on, error information is displayed at bit 2 of address 27~30.
- (d) In case of PUT instruction, average processing setting method is as follows.

<b>Address "10"</b>	B15 B14 B13 B12 B11 B10 B9 B8 B7 B6 B5 B4 B3 B2 B1 B0	CH# average processing method setting
<b>Address "11"</b>		0: Sampling
<b>Address "12"</b>		1: Time-average
<b>Address "13"</b>		2: Count-average
		3: Moving-average

(e) This area shows the same results with average processing method setting in I/O parameter setting window.

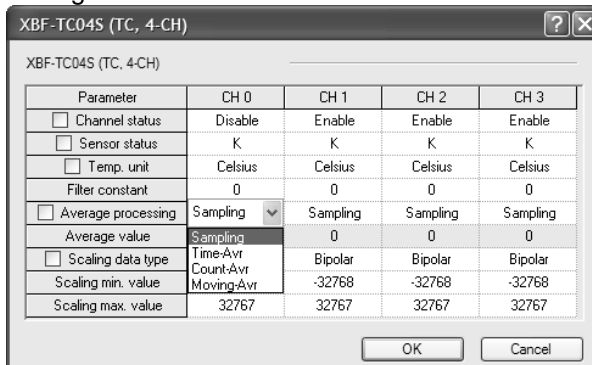

- (6) Average value setting area (Address 14~17)
  - (a) Average value can be set per channel.
  - (b) In case average processing method is sampling, values of this area are ignored.
  - (c) In case of using PUT instruction, average value setting address is as follows.

<b>Address "14"</b>	CH# average value setting Time-average: 400 ~ 64000[ms] Count-average: 2 ~ 64000[times] Moving-average: 2 ~ 100
<b>Address "15"</b>	
<b>Address "16"</b>	
<b>Address "17"</b>	

- (d) When input is out of range, the min. value of each address is selected by force.  
 But, U0x.01.8~ U0x.01.B (setting error representation, in case of IEC type, %UX0.x.24 ~ %UX0.x.27) are on, error information is displayed at bit 3~5 of address 27~30.  
 (Bit 3: time-average, bit 4: count-average, bit 5: moving-average)  
 Ex.) When selecting the Time-average and setting average value as 200, 400ms is selected in address "14" by force.
- (e) This area shows the same results with average value setting in I/O parameter setting window.  
 In the I/O parameter setting window, prohibition function is provided not to set value that is out of range. (In case of setting value that is out of range, that values are displayed with red color and error message is displayed.)

1) Time-Avr.

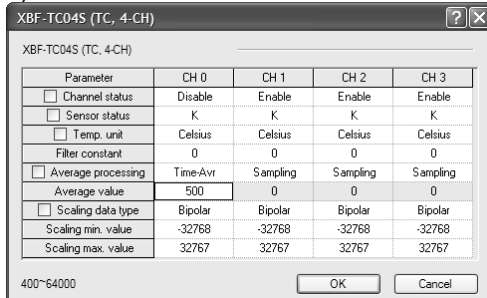

2) Count-Avr.

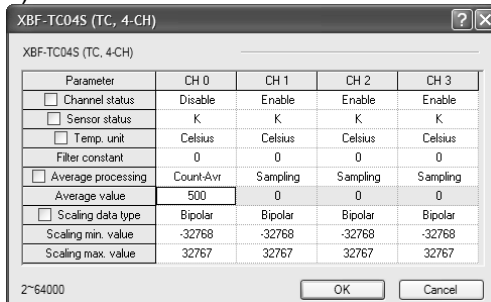

3) Moving-Avr.

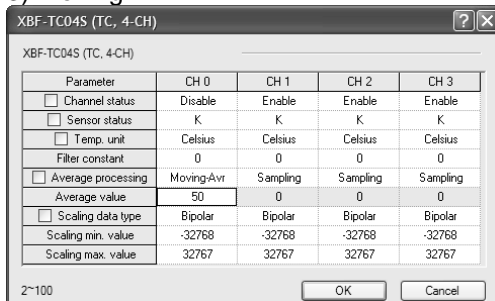

(7) Scaling data type setting area (address 18)

- (a) Scaling data type can set per channel.
- (b) There are two type of scaling operation output, unsigned 16 bit (0~65535) or signed 16 bit (-32768~32768).
- (c) In case of using PUT instruction, scaling data type setting address is as follows.

Address "0"

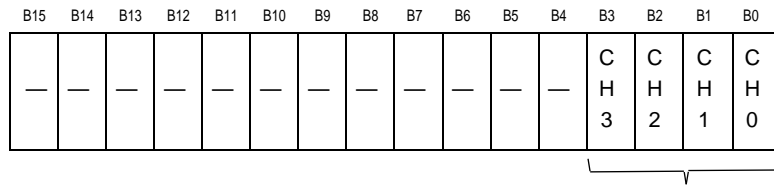

Bit	Description
0	Signed integer
1	Unsigned integer

- (d) Values set in B4~15 are ignored.
- (e) This area shows the same results with Scaling data type setting in I/O parameter setting window.

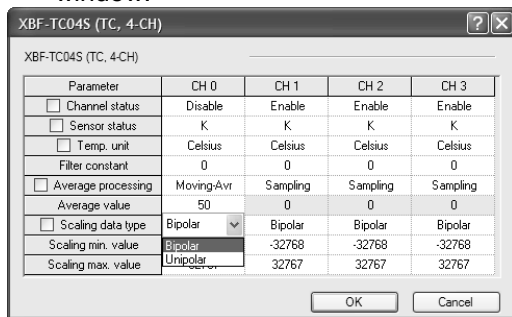

(8) Scaling min./max. value setting area (Address 19~26)

- (a) Scaling min./max. value can be set per channel.
- (b) There are two type of scaling operation output, unsigned 16 bit (0~65535) or signed 16 bit (-32768~32767).
- (c) In case of using PUT instruction, scaling min./max. value setting address is as follows.

- Address "19"
- Address "20"
- Address "21"
- Address "22"
- Address "23"
- Address "24"
- Address "25"
- Address "26"

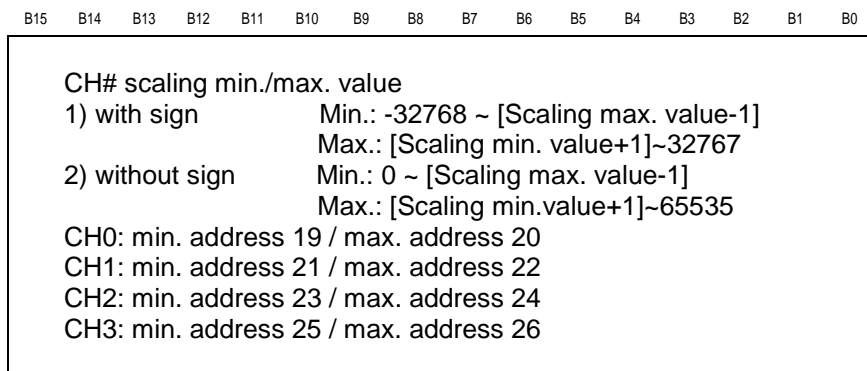

- (d) If input is out of range, it keeps previous value.  
But, U0x.01.8~ U0x.01.B (setting error representation, in case of IEC type, %UX0.x.24~%UX0.x.27) are on, error information is displayed at bit 6 of address 27~30.

(e) This area shows the same results with Scaling min./max. value setting in I/O parameter setting window.

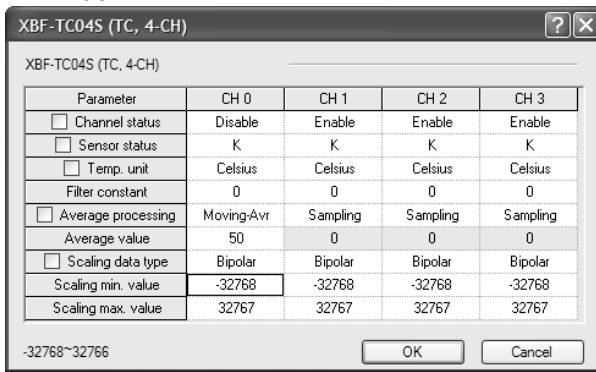

Scaling data type	Scaling min. value	Scaling max. value
Signed	-32768 ~ [Scaling max. value -1]	[Scaling min. value+1] ~ 32767
Unsigned	0 ~ [Scaling max. value-1]	[Scaling min. value+1] ~ 65535

(9) Setting error information area (address 27~30)

(a) If there is error when setting parameter (address 1~26), error information is displayed at address 27~30 per channel.

(b) In case of GET instruction, setting error information address is as follows.

	B15	B14	B13	B12	B11	B10	B9	B8	B7	B6	B5	B4	B3	B2	B1	B0
Address "27"	CH0 setting error information															
Address "28"	CH1 setting error information															
Address "29"	CH2 setting error information															
Address "30"	CH3 setting error information															

Bit	Description	Related memory address	
		Hex.	Dec.
Bit0	Sensor type (Off: normal, On: error)	01H~04H	1~4
Bit1	Filter constant (Off: normal, On: error)	06H~09H	6~9
Bit2	Average processing method (Off: normal, On: error)	0AH~0DH	10~13
Bit3	Time-average value (Off: normal, On: error)	0EH~11H	14~17
Bit4	Count-average value (Off: normal, On: error)		
Bit5	Moving-average value (Off: normal, On: error)		
Bit6	Scaling range (Off: normal, On: error)	13H~1AH	19~26

(c) In case there is error, setting error representation flag (U0x.01.8 ~ U0x.01.B, in case of IEC type, %UX0.x.24 ~ %UX0.x.27) will be on, it acts as default value.

If setting error representation flag (U0x.01.8 ~ U0x.01.B) is on, check error information 1BH ~ 1FH (27~30) area and solve the error.

- (10) Cold junction compensation temp. area (Address 31~34)  
 (a) Cold junction compensation temp. can be seen per channel.  
 (b) In case of GET instruction, cold junction compensation temp. area is as follows.

	B15	B14	B13	B12	B11	B10	B9	B8	B7	B6	B5	B4	B3	B2	B1	B0
<b>Address "31"</b>	CH0 cold junction compensation temp.															
<b>Address "32"</b>	CH1 cold junction compensation temp.															
<b>Address "33"</b>	CH2 cold junction compensation temp.															
<b>Address "34"</b>	CH3 cold junction compensation temp.															

- (11) System area (offset gain storage area: address 35~63)  
 (a) In the system area, Read/Write is unavailable.

	<b>Caution</b>	If the user changes this area, it may cause malfunction or breakdown. So do not handle this area.
---	----------------	--

## 5.7 Example Program

- (1) It describes how to set operation parameter in the internal memory of thermocouple module.
- (2) Regarding the initial condition, the initial settings are saved in the internal memory of thermocouple module if saved once.
- (3) The following is program example that reads the temp. value of thermocouple input module of slot 1 and check whether disconnection occurs or not.

### 5.7.1 Example using [I/O Parameter]

#### (1) I/O parameter setting window

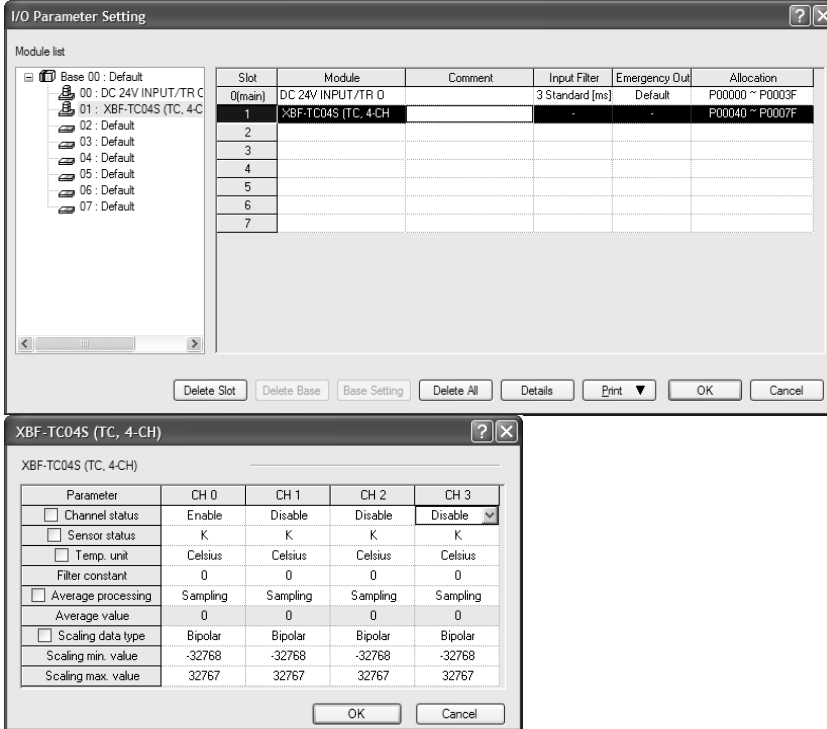

#### (2) Program example

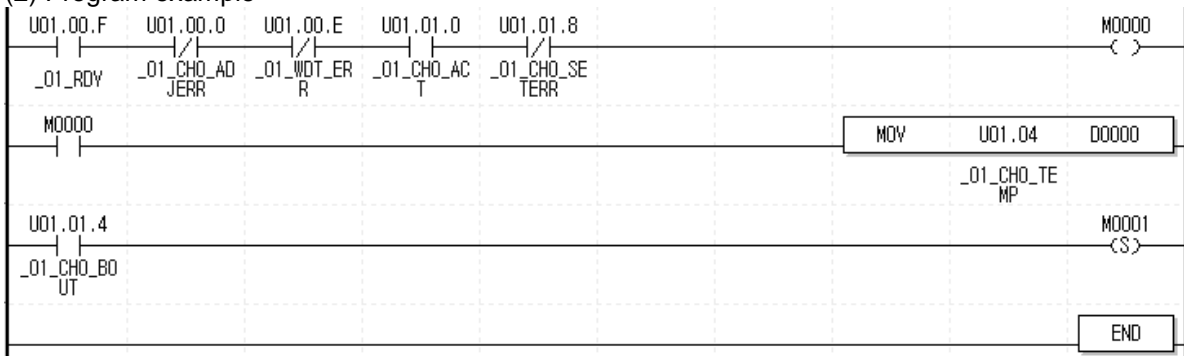

- (a) If module is under normal operation, M0000 is on.  
 U01.00.F(module Ready) = On  
 U01.00.0(CH0 offset/gain adjustment error) = Off  
 U01.00.E(module H/W error) = Off  
 U01.00.E(CH0 running) = On
- (b) If M0000 is on, temp. conversion value (U01.04) of CH0 moves to D0000.
- (c) If disconnection error occurs at CH0, U01.01.4 (CH0 disconnection) is on and M0001 bit is set.

(3) Program example (in case of IEC type)

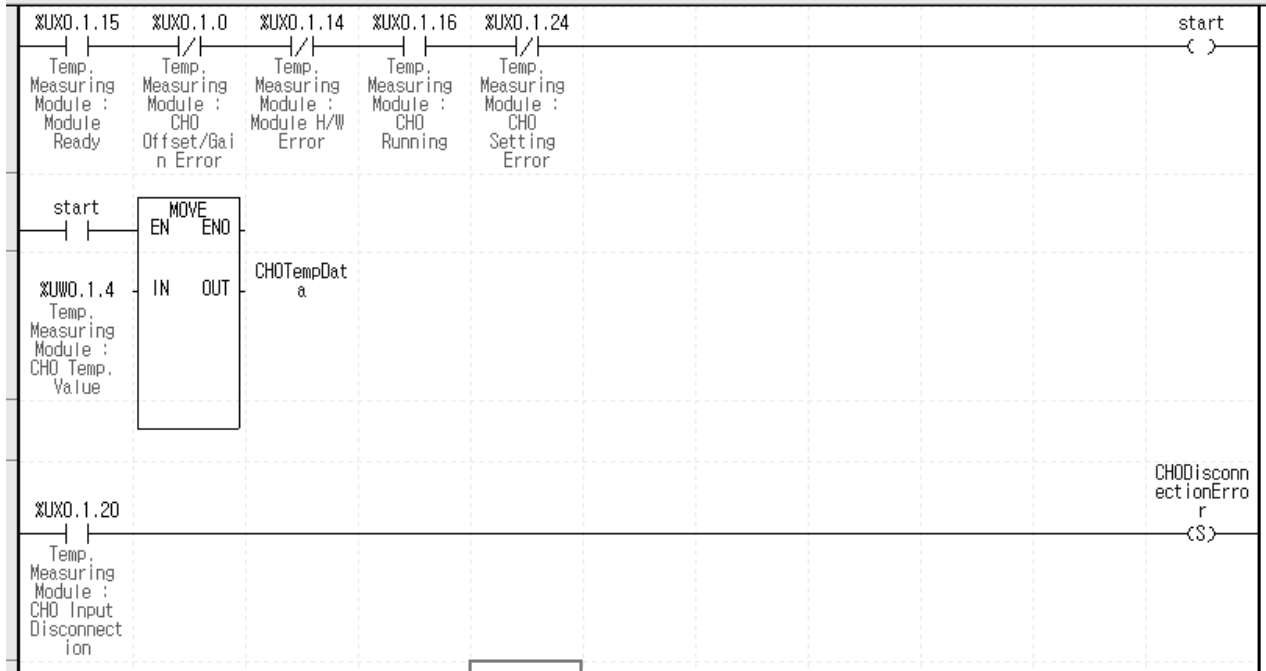

- (a) If module is running normally, operation start bit is on
  - %UX0.1.15 (Module Ready) = On
  - %UX0.1.0 (CH 0 offset/gain adjustment error) = Off
  - %UX0.1.14 (Module H/W error) = Off
  - %UX0.1.16 (CH 0 running) = On
  - %UX0.1.24 (Setting error) = Off
- (b) If operation start bit is on, it moves CH 0 temp. conversion value (%UW0.1.4) into CH 0 temp. data
- (c) If CH 0 disconnection error occurs, %UX0.1.20 (CH0 disconnection) is on and CH 0 disconnection error bit is set

5.7.2 Program example using PUT/GET instruction

(1) Program example

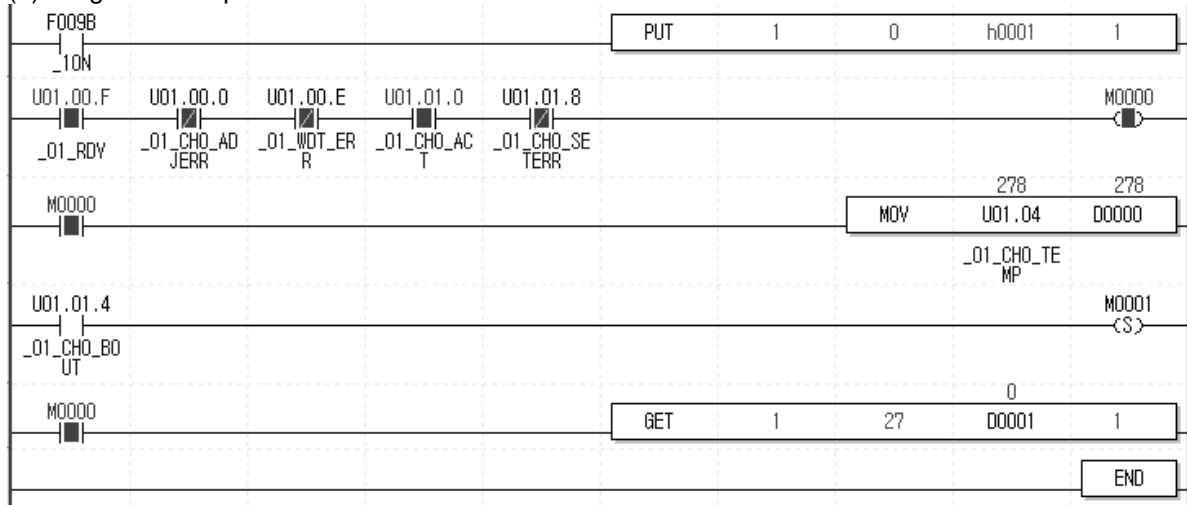

- (a) It writes h0001 at address 0 of slot 1 in order to enable CH0.
- (b) If module is under normal operation, M0000 is on.  
 U01.00.F(module Ready) = On  
 U01.00.0(CH0 offset/gain adjustment error) = Off  
 U01.00.E(module H/W error) = Off  
 U01.00.E(CH0 running) = On
- (c) If M0000 is on, temp. conversion value of CH0 moves to D0000.  
 Current temp. conversion value, 278(27.8°C<sup>2</sup>) is saving in U01.04.
- (d) If disconnection error occurs at CH0, U01.01.4 (CH0 disconnection) is on and M0001 bit is set.
- (e) If M0000 is on, setting error (address 27) of CH0 moves to D0001. Since setting error (address 27) of CH0 is 0, there is no setting error.



(2) Program example (in case of IEC type)

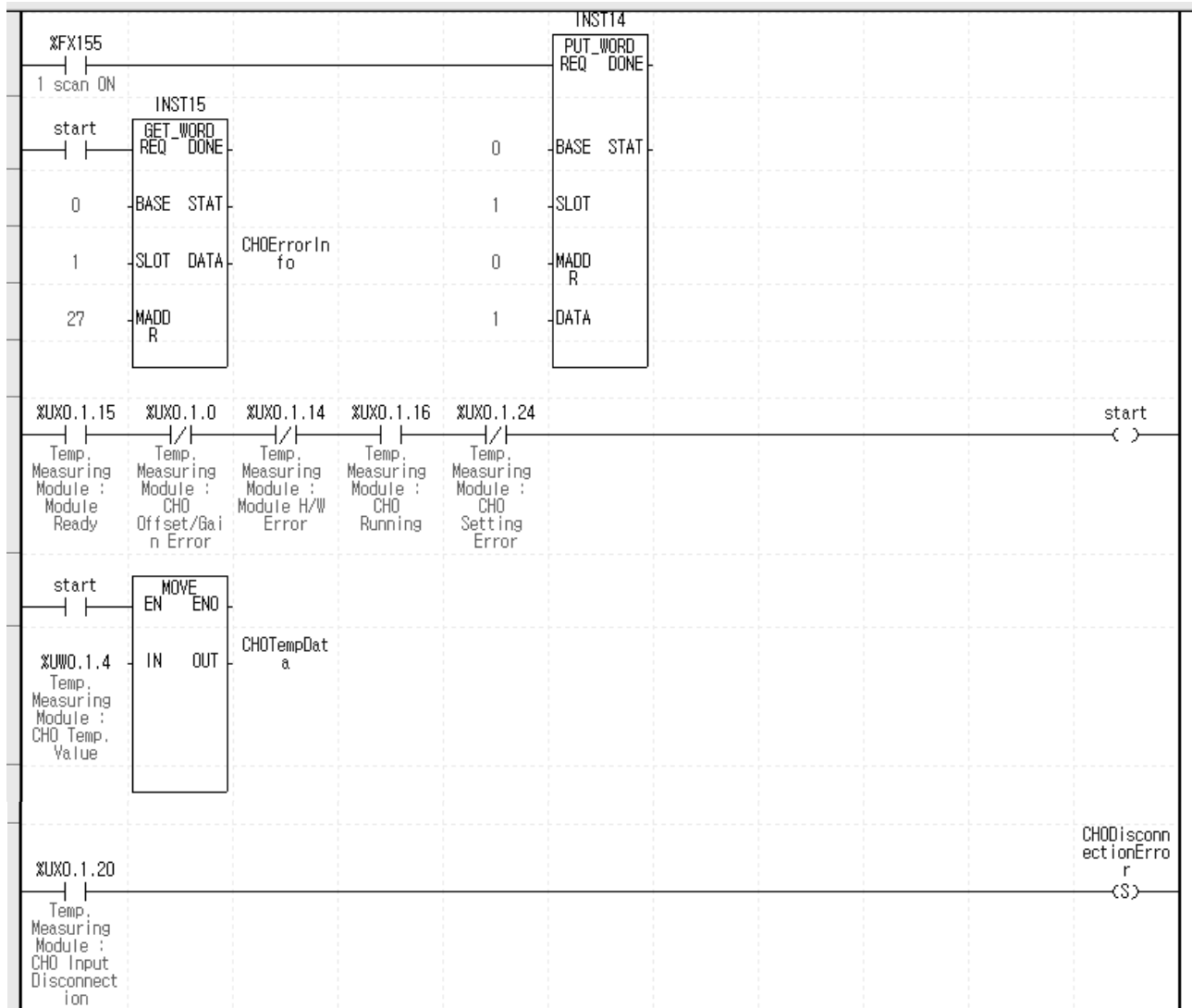

- (a) Writes 1 at address 0 of slot 1 and operates CH 0 by using PUT\_WORD function block.
- (b) If operation start bit is on, reads CH 0 setting error (address 27) and moves it into D0001.
- (c) If module is running normally, operation start bit is on.
  - $\%UX0.1.15$  (module Ready) = On
  - $\%UX0.1.0$  (CH 0 offset/gain adjustment error) = Off
  - $\%UX0.1.14$  (Module H/W error) = Off
  - $\%UX0.1.16$  (CH 0 running) = On
  - $\%UX0.1.24$  (setting error) = Off
- (d) Operation start bit is on, moves CH 0 temp. conversion value ( $\%UW0.1.4$ ) into CH 0 temp. data
- (e) Disconnection error occurs at CH 0,  $\%UX0.1.20$  (CH 0 disconnection) is on and CH 0 disconnection error bit is set.

5.7.3 Example when error occurs

(1) Program example

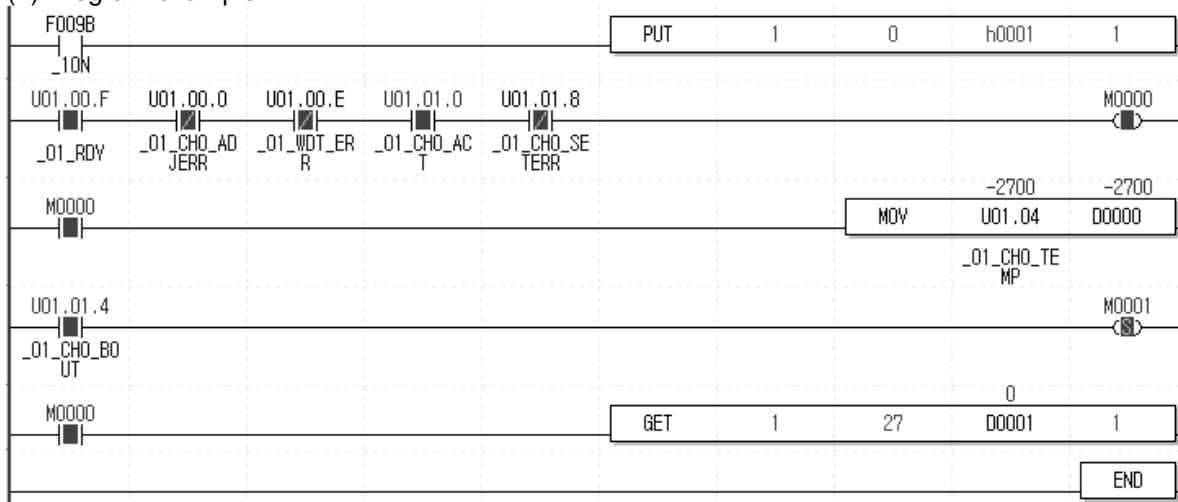

- (a) If disconnection error occurs at CH0, U01.01.4 (CH0 disconnection) is on and M0001 bit is set.
- (b) If disconnection error occurs at CH0, min. value within the range of K type temperature sensor is displayed at U01.04.
- (c) It is monitored as follows according to monitor display type.

When monitoring the temp. conversion value, select "Unsigned Decimal".

Monitor display type	Display content
Unsigned Decimal	62836
Signed Decimal	-2700 (-270.0°C)
Hexadecimal	hF574
As Instruction	62836

## 5.8 Troubleshooting

The chapter describes diagnostics and measures in case any trouble occurs during use of thermocouple input module.

### 5.8.1 LED Indication by Errors

Thermocouple input module has two LEDs and it is possible to check whether it had any error with the indication of RUN LED and ALM LED.

Item	Normal	Disconnection	Abnormal module H/W (error)
RUN LED	ON	ON	Flicker every 0.2 second
ALM LED	OFF	Flicker every second	OFF
Operation	Normal operation Every function works	Every function works Min. temp. is displayed	Module function stops
Management	-	Checking sensor wiring	Customer service

### 5.8.2 Stats check of module through XG5000 system monitor

Module type, module information, O/S version and module status of thermocouple input module can be checked through XG5000 system monitoring function.

#### (1) Execution sequence

Two routes are available for the execution.

- (a) [Monitor] -> [System Monitoring] -> And on the module screen, click the right mouse button to display [Module Information].
- (b) [Monitor] -> [System Monitoring] -> And Double-click the module screen.

#### (2) Module information

- (a) Module type: shows the information of the module presently installed.
- (b) Module information: shows the O/S version information of module.
- (c) O/S version: shows the O/S prepared date of module.

### 5.8.3 Troubleshooting

(1) RUN LED flickers.

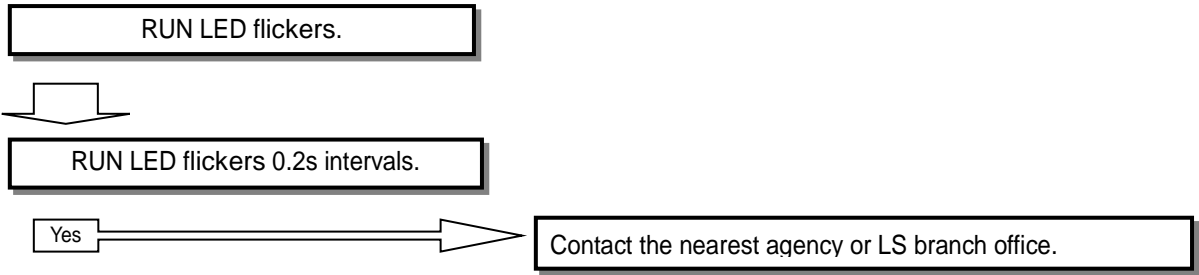

(2) RUN LED is off.

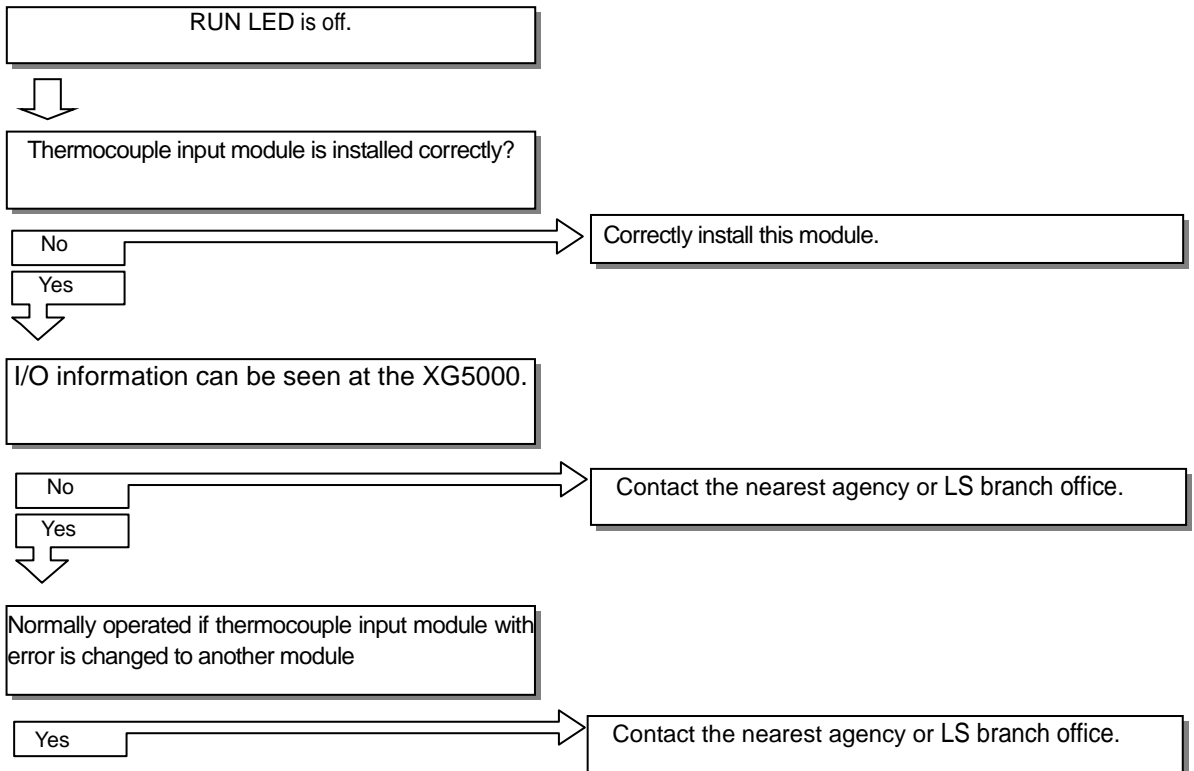

(3) ALM LED flickers.

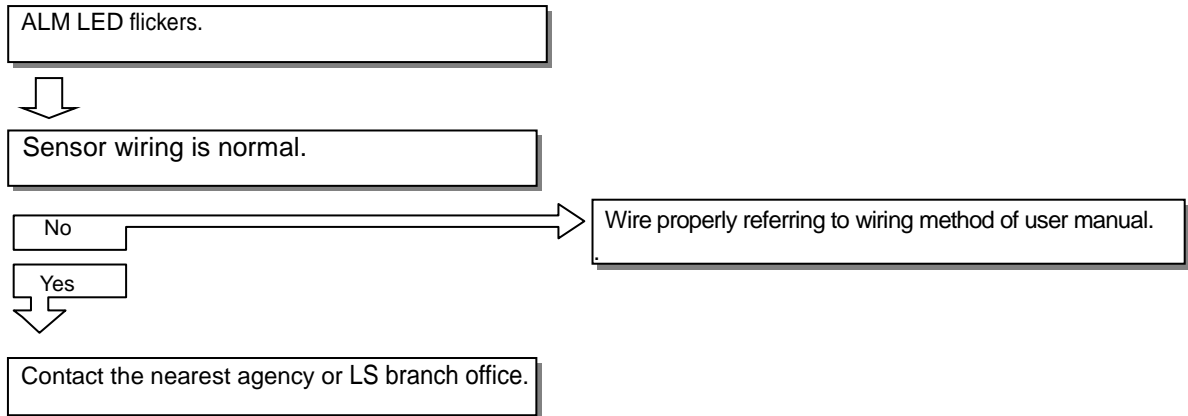

(4) Temperature conversion value is not normal.

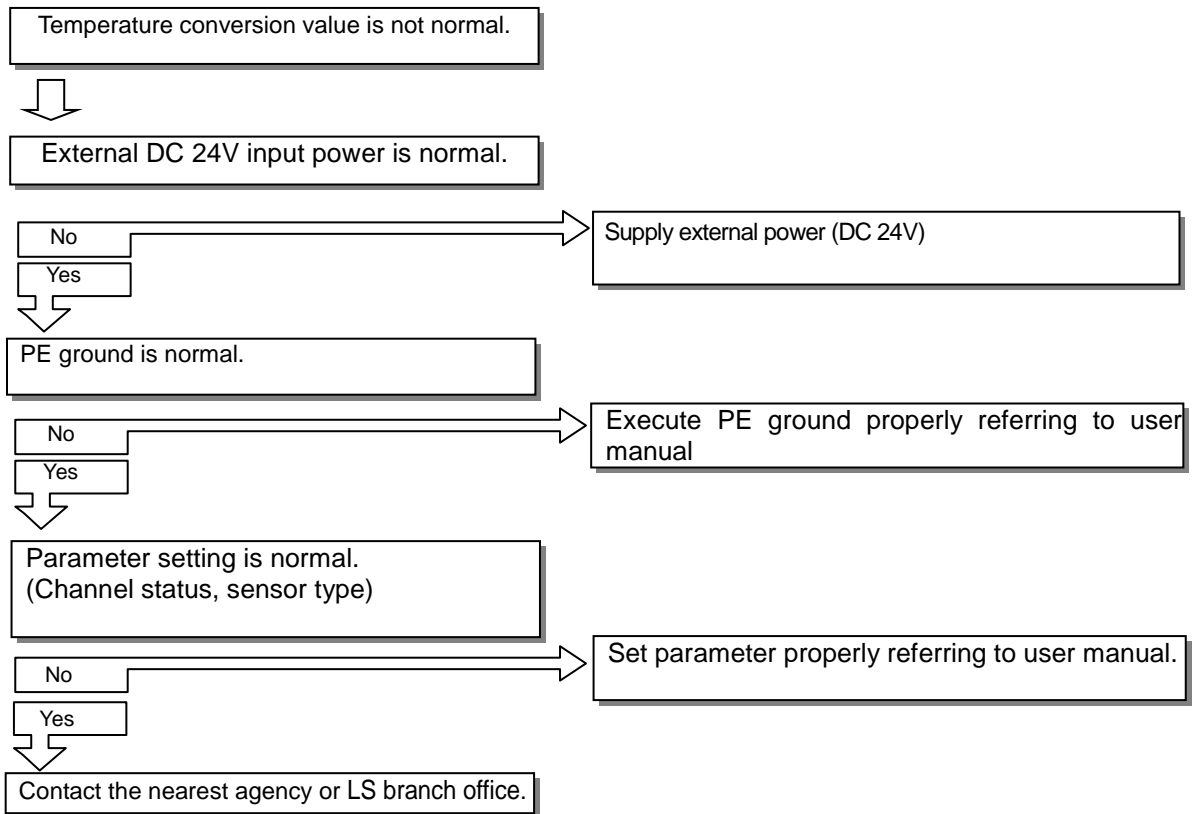

5.8.4 Error code and measure

(1) Measure when error flag of data I/O area (U device) occurs.

Device assignment ('S', 'H' type)	Device assignment (IEC type)	Description	Content	Measure
U0x.00.0	%UX0.x.0	CH0 offset/gain adjustment error	On: error Off: normal	If repeated when restarting the power, contact custom service center
U0x.00.1	%UX0.x.1	CH1 offset/gain adjustment error		
U0x.00.2	%UX0.x.2	CH2 offset/gain adjustment error		
U0x.00.3	%UX0.x.3	CH3 offset/gain adjustment error		
U0x.00.D	%UX0.x.13	Module offset/gain backup error		If repeated when restarting the power, contact custom service center
U0x.00.E	%UX0.x.14	Module HW error		If repeated when restarting the power, contact custom service center
U0x.01.8	%UX0.x.24	CH0 setting error	Parameter setting On: setting error Off: setting normal	Check the parameter setting area (address 27~30) by GET instruction, solve the setting error contents.
U0x.01.9	%UX0.x.25	CH1 setting error		
U0x.01.A	%UX0.x.26	CH2 setting error		
U0x.01.B	%UX0.x.27	CH3 setting error		

(2) Checking error information area (address 27~30) of operation parameter area

(a) Setting error information area (address 27~30)

Bit	Description	Related memory address	
		Hex.	Dec.
Bit0	Sensor type setting (Off: normal, On: error)	01H~04H	1~4
Bit1	Filter constant setting (Off: normal, On: error)	06H~09H	6~9
Bit2	Average processing method setting (Off: normal, On: error)	0AH~0DH	10~13
Bit3	Time average value (Off: normal, On: error)	0EH~11H	14~17
Bit4	Count average value (Off: normal, On: error)		
Bit5	Moving average value (Off: normal, On: error)		
Bit6	Scaling range (Off: normal, On: error)	13H~1AH	19~26

(b) Checking setting error information

Check the setting error information (address 27~30) area by GET instruction.

Ex.1) In case thermocouple input module is mounted at slot 1.

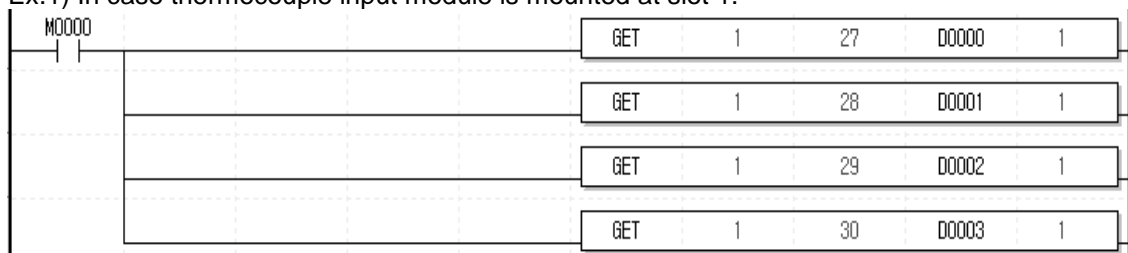

Ex.2) In case thermocouple input module is mounted at slot 1. (In case of IEC)

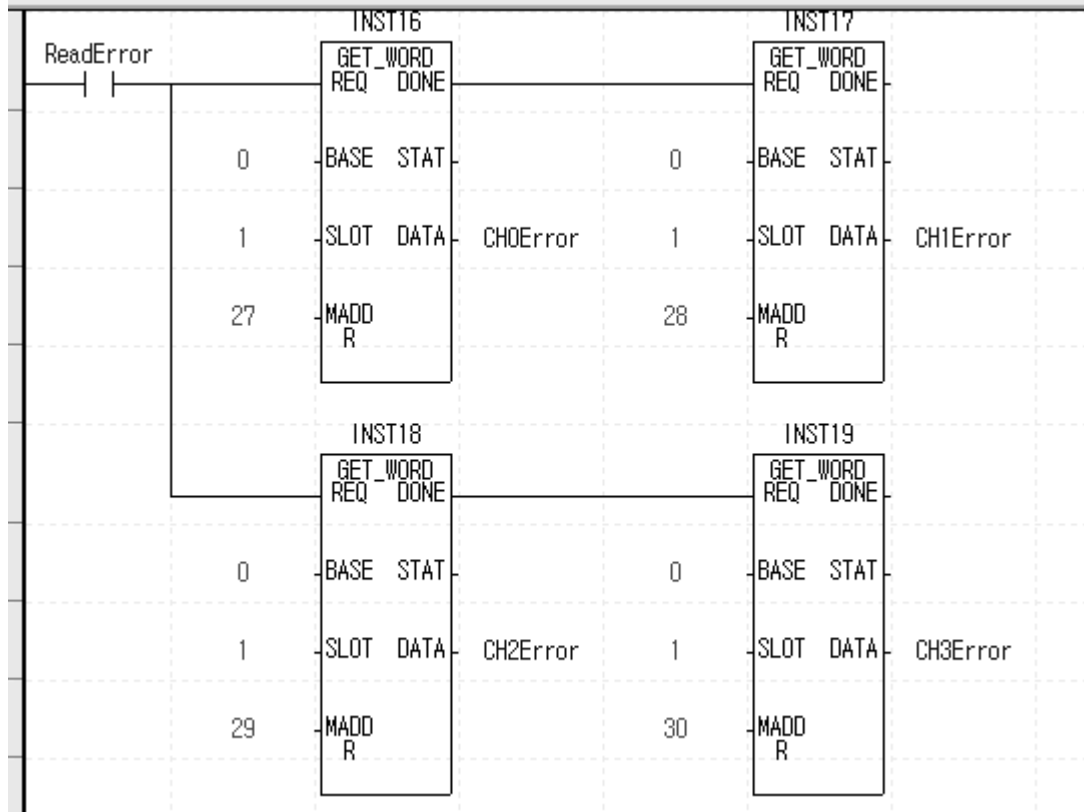

(c) In case setting error occurs, setting error representation flag (U0x.01.8~ U0x.01.B, in case of IEC type %UX0.x.24 ~ %UX0.x.27) will be on and it will act as default value. If setting error representation flag (U0x.01.8~ U0x.01.B, in case of IEC type, %UX0.x.24 ~ %UX0.x.27) is on, check above setting error information 1B<sub>H</sub> ~ 1F<sub>H</sub> (address 27~30) area, check related memory address 01<sub>H</sub> ~ 1A<sub>H</sub> (address 1~26) and cancel error.r

# Chapter 6 Analog I/O Module

## 6.1 Pre-operation Setting Procedure

Please proceed as follows before operating analog I/O module.

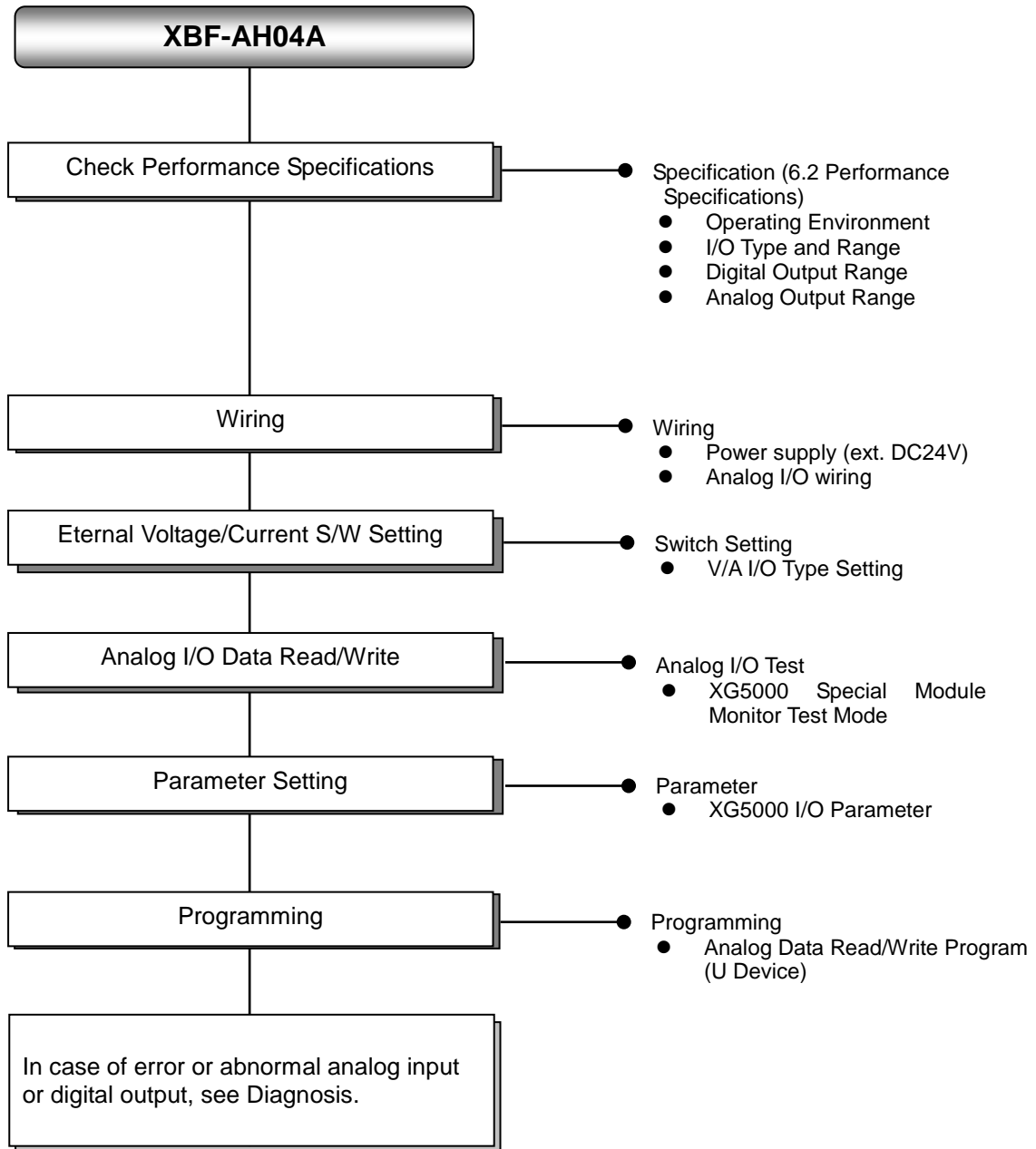



## 6.2 Specification

### 6.2.1 General Specification

This section describes general specifications of the analog I/O module.

No.	Item	Specifications	Related specifications			
1	Ambient temperature	0°C ~ +55°C	-			
2	Storage temperature	-25°C ~ +70°C	-			
3	Ambient humidity	5 ~ 95%RH (Non-condensing)	-			
4	Storage humidity	5 ~ 95%RH (Non-condensing)	-			
5	Vibration resistance	Occasional vibration			-	IEC61131-2
		Frequency	Acceleration	Amplitude	How many times	
		5 ≤ f < 8.4 Hz	-	3.5 mm	10 times each directions (X, Y and Z)	
		8.4 ≤ f ≤ 150 Hz	9.8 m/s <sup>2</sup> (1G)	-		
		For continuous vibration				
		Frequency	Acceleration	Amplitude	10 times each directions (X, Y and Z)	
		5 ≤ f < 8.4 Hz	-	1.75 mm		
8.4 ≤ f ≤ 150 Hz	4.9 m/s <sup>2</sup> (0.5G)	-				
6	Shock resistance	<ul style="list-style-type: none"> <li>Peak acceleration: 147 m/s<sup>2</sup>(15G)</li> <li>Duration: 11ms</li> <li>Half-sine, 3 times each direction per each axis</li> </ul>	IEC61131-2			
7	Noise resistance	Square wave Impulse noise	AC: ± 1,500V DC: ± 900V	LS ELECTRIC standard		
		Electrostatic discharge	Voltage : 4kV (contact discharging)	IEC 61131-2, IEC 61000-4-2		
		Radiated electromagnetic field noise	80 ~ 1,000 MHz, 10V/m	IEC 61131-2, IEC 61000-4-3		
		Fast transient /bust noise	Segment Voltage	Power supply module 2kV	Digital/analog input/output communication interface 1kV	IEC 61131-2, IEC 61000-4-4
8	Environment	Free from corrosive gasses and excessive dust	-			
9	Altitude	Up to 2,000 ms	-			
10	Pollution degree	Less than equal to 2	-			
11	Cooling	Air-cooling	-			

### 6.2.2 Performance Specification

This section specified the performance of analog I/O module.

#### (1) Input Performance Specification

Classification		Input Performance Specification		
No. input channels		2 channels		
Analog Input Range	Type	Voltage	Current	
	Range	DC 1 ~ 5V DC 0 ~ 5V DC 0 ~ 10V (Input resistance: 1 MΩ min.)	DC 4 ~ 20mA DC 0 ~ 20mA (Input resistance 250 Ω)	
		Input range shall be specified in user program or I/O parameters by channel, and selected with external voltage/current switches.		
	Type		12-bit binary data	
Digital Output	Value Range	Unsigned	0 ~ 4000	
		Signed	-2000 ~ 2000	
		Precise Value	100 ~ 500 (DC 1 ~ 5V) 0 ~ 500 (DC 0 ~ 5V) 0 ~ 1000 (DC 0 ~ 10V)	400 ~ 2000 (DC 4 ~ 20mA) 0 ~ 2000 (DC 0 ~ 20mA)
		Percentile Value	0 ~ 1000	
Max. Resolution		1/4000		
		1.25mV (DC 1~5V, 0~5V) 2.5mV (DC 0~10V)	5μA (DC4~20mA, 0~20mA)	
Precision		±0.5% max.		
Max. Conversion Rate		1ms/channel		
Max. Absolute Input		DC ±15V	DC ±25mA	
Additional Functions	Filtration	Digital filter (4 ~ 64,000ms)		
	Averaging	Time average (4~16,000ms)		
		Cycle average (2~64,000 cycles)		
		Moving average (2~100 values)		
	Alarm	Open line detection (DC 1~5V, DC4~20mA)		

## (2) Output Performance Specification

Classification		Output Performance Specification		
No. of output channels		2 channels		
Analog Output Range	Type	Voltage	Current	
	Range	DC 1 ~ 5V DC 0 ~ 5V DC 0 ~ 10V (Load resistance: 2kΩ min.)	DC 4 ~ 20mA DC 0 ~ 20mA (Load resistance: 510 Ω max.)	
	Output range shall be specified in user program or I/O parameters by channel, and selected with external voltage/current switches.			
Digital Input	Type	12-bit binary data		
	Value Range	Unsigned	0 ~ 4000	
		Signed	-2000 ~ 2000	
		Precise Value	100 ~ 500 (DC 1 ~ 5V) 0 ~ 500 (DC 0 ~ 5V) 0 ~ 1000 (DC 0 ~ 10V)	400 ~ 2000 (DC 4 ~ 20mA) 0 ~ 2000 (DC 0 ~ 20mA)
Percentile Value		0 ~ 1000		
Max. Resolution		1/4000		
		1.25mV (DC 1~5V, 0~5V) 2.5mV (DC 0~10V)	5μA (DC4~20mA, 0~20mA)	
Precision		±0.5% max.		
Max. Conversion Rate		1ms/channel		
Max. Absolute Output		DC ±15V	DC 25mA	
Additional Functions		Channel output status setting function (selectable from previous, min., mean, max. value outputs)		

## (3) I/O Common Performance Specification

Classification		I/O Common Performance Specification	
Insulation Type		Photo-coupler isolation between I/O terminal and PLC power source (no insulation between channels)	
I/O Terminals		11 point terminal block	
I/O Points		Fixed type: 64 points	
Max. No. of Installation		7 [When using XBM-Dxxx□ (□:"S", "H", "H2", "HP") type] 7 (when using XB(E)C-DxxxSU type) 10 (when using XB(E)C-DxxxH type or XB(E)C-DxxxU type) Not Available (when using XB(E)C-DxxxE type)	
Current	Internal (DC 5V)	120mA	
	External (DC 24V)	130mA	
Weight		73g	
Power Supply		DC 20.4 ~ 28.8V	

Note1) In order to use analog I/O module, the following version is needed.

Main unit	Version information
XBM-DxxxS type	V2.4
XBC-DxxxH type	V1.7
XEC-DxxxH type	V1.0
XEC-DxxxS type	V1.0

### 6.3 Major Components

Major components are as follows;

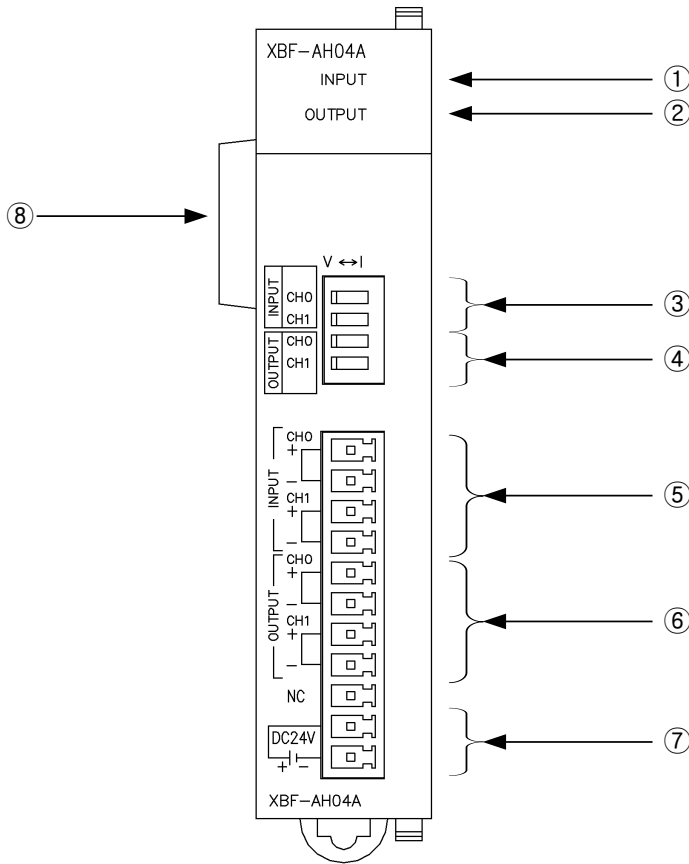

No.	Name	Description
①	INPUT LED	▶ Indicate operation of input part On: normal operation Flickering: in error (1s intervals) Off: power off or module failure
②	OUTPUT LED	▶ Indicate operation of output part On: normal operation Flickering: in error (1s intervals) Off: power off or module failure
③	Input Volt/Current Select Switch	▶ Switch for selecting voltage/current input of analog input Ch 0 and Ch 1
④	Output Volt/Current Select Switch	▶ Switch for selecting voltage/current output of analog output Ch 0 and Ch 1
⑤	Input Terminal Block	▶ Terminal block for analog input wiring with external devices
⑥	Output Terminal Block	▶ Terminal block for analog output wiring with external devices
⑦	Ext. Power Connector	▶ Connector for DC24V external power supply
⑧	Ext. Connector	▶ Connector for extension modules

## 6.4 Conversion Characteristics by I/O Range

The input/output ranges of voltage and current can be set up per channel with user program or I/O parameters. The I/O types of digital data are defined as follows.

- (1) Unsigned Value
- (2) Signed Value
- (3) Precise Value
- (4) Percentile Value

### 6.4.1 Input Characteristics

The graph below shows the data conversion characteristics by input range.

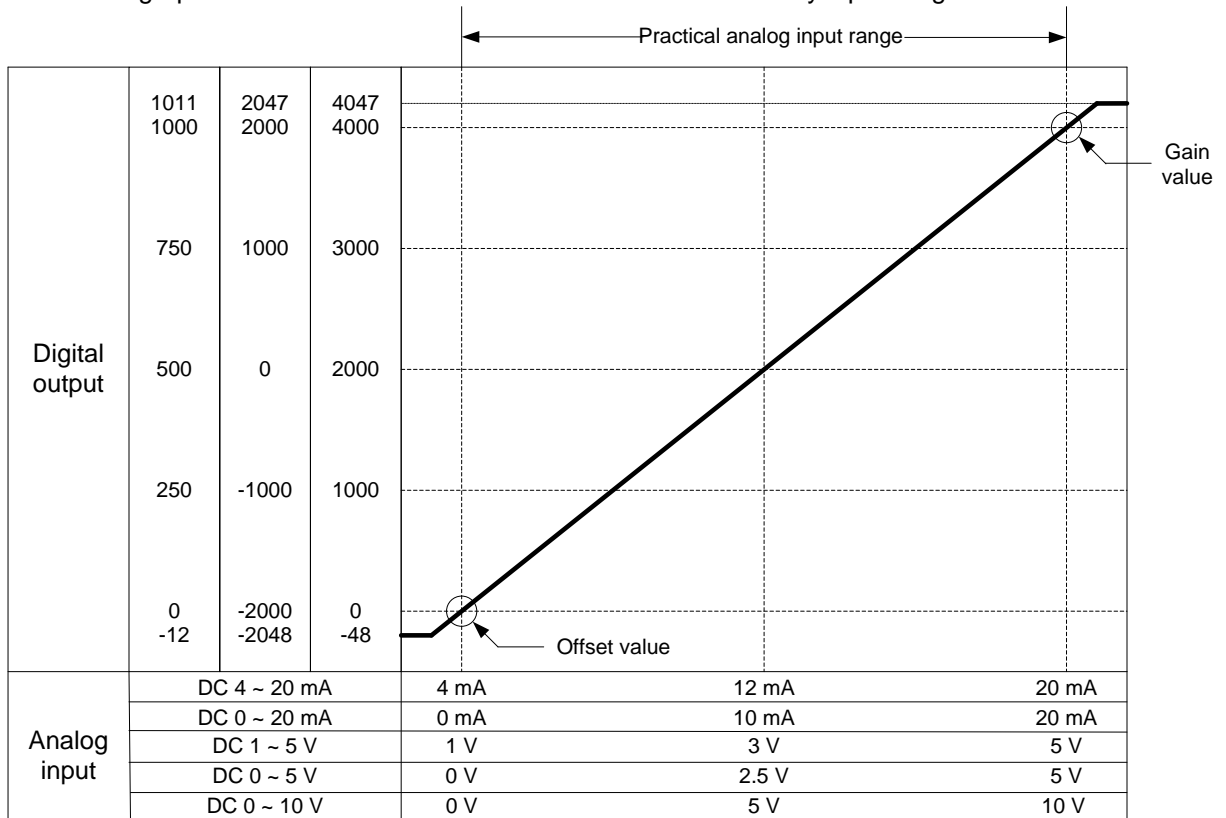

#### (1) DC 4 ~ 20mA Range Input

Digital Output Range	Analog Input Current (mA)						
	3.81	4	8	12	16	20	20.18
Unsigned Value (0 ~ 4000)	-48	0	1000	2000	3000	4000	4047
Signed Value (-2000 ~ 2000)	-2048	-2000	-1000	0	1000	2000	2047
Precise Value (400 ~ 2000)	381	400	800	1200	1600	2000	2018
Percentile Value(0 ~ 1000)	-12	0	250	500	750	1000	1011

(2) DC 0 ~ 20mA Range Input

Digital Output Range	Analog Input Current (mA)						
	-0.24	0	5	10	15	20	20.23
Unsigned Value (0 ~ 4000)	-48	0	1000	2000	3000	4000	4047
Signed Value (-2000 ~ 2000)	-2048	-2000	-1000	0	1000	2000	2047
Precise Value (0 ~ 2000)	-24	0	500	1000	1500	2000	2023
Percentile Value(0 ~ 1000)	-12	0	250	500	750	1000	1011

(3) DC 1 ~ 5V Range Input

Digital Output Range	Analog Input Voltage (V)						
	0.96	1	2	3	4	5	5.04
Unsigned Value (0 ~ 4000)	-48	0	1000	2000	3000	4000	4047
Signed Value (-2000 ~ 2000)	-2048	-2000	-1000	0	1000	2000	2047
Precise Value (100 ~ 500)	96	100	200	300	400	500	504
Percentile Value(0 ~ 1000)	-12	0	250	500	750	1000	1011

(4) DC 0 ~ 5V Range Input

Digital Output Range	Analog Input Voltage (V)						
	-0.06	0	1.25	2.5	3.75	5	5.05
Unsigned Value (0 ~ 4000)	-48	0	1000	2000	3000	4000	4047
Signed Value (-2000 ~ 2000)	-2048	-2000	-1000	0	1000	2000	2047
Precise Value (0 ~ 500)	-6	0	125	250	375	500	505
Percentile Value(0 ~ 1000)	-12	0	250	500	750	1000	1011

(5) DC 0 ~ 10V Range Input

Digital Output Range	Analog Input Voltage (V)						
	-0.12	0	2.5	5	7.5	10	10.11
Unsigned Value (0 ~ 4000)	-48	0	1000	2000	3000	4000	4047
Signed Value (-2000 ~ 2000)	-2048	-2000	-1000	0	1000	2000	2047
Precise Value (0 ~ 1000)	-12	0	250	500	750	1000	1011
Percentile Value(0 ~ 1000)	-12	0	250	500	750	1000	1011

### 6.4.2 Output Characteristics

The graph below shows the data conversion characteristics by output range.

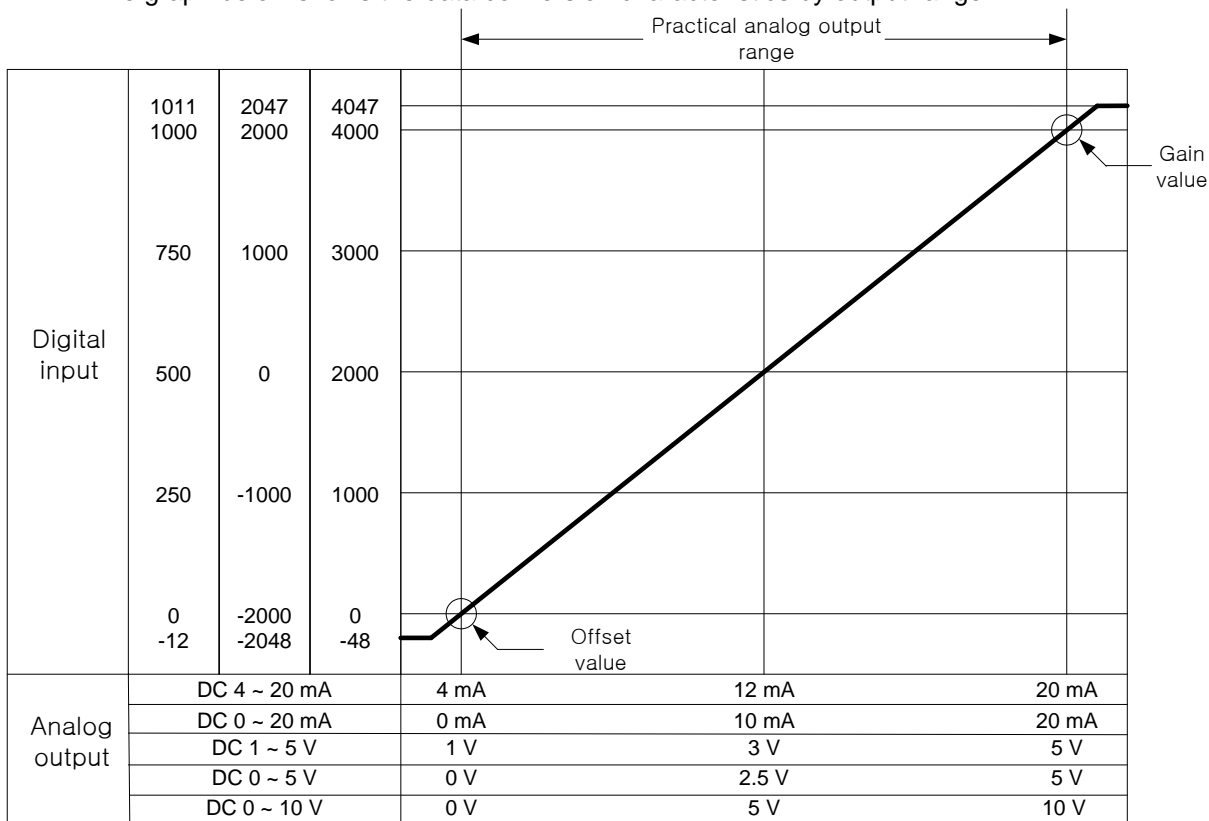

(1) DC 4 ~ 20mA Range Output

Digital Input Range	Analog Output Current (mA)						
	4mA less	4	8	12	16	20	20mA over
Unsigned Value (0 ~ 4000)	0 less	0	1000	2000	3000	4000	4000 over
Signed Value (-2000 ~ 2000)	-2000 less	-2000	-1000	0	1000	2000	2000 over
Precise Value (400 ~ 2000)	400 less	400	800	1200	1600	2000	2000 over
Percentile Value(0 ~ 1000)	0 less	0	250	500	750	1000	1000 over

(2) DC 0 ~ 20mA Range Output

Digital Input Range	Analog Output Current (mA)						
	0mA less	0	5	10	15	20	20mA over
Unsigned Value (0 ~ 4000)	0 less	0	1000	2000	3000	4000	4000 over
Signed Value (-2000 ~ 2000)	-2000 less	-2000	-1000	0	1000	2000	2000 over
Precise Value (0 ~ 2000)	0 less	0	500	1000	1500	2000	2000 over
Percentile Value(0 ~ 1000)	0 less	0	250	500	750	1000	1000 over

(3) DC 1 ~ 5V Range Output

Digital Input Range	Analog Output Voltage (V)						
	1V less	1	2	3	4	5	5V over
Unsigned Value (0 ~ 4000)	0 less	0	1000	2000	3000	4000	4000 over
Signed Value (-2000 ~ 2000)	-2000 less	-2000	-1000	0	1000	2000	2000 over
Precise Value (100 ~ 500)	100 less	100	200	300	400	500	500 over
Percentile Value(0 ~ 1000)	0 less	0	250	500	750	1000	1000 over

(4) DC 0 ~ 5V Range Output

Digital Input Range	Analog Output Voltage (V)						
	0V less	0	1.25	2.5	3.75	5	5V over
Unsigned Value (0 ~ 4000)	0 less	0	1000	2000	3000	4000	4000 over
Signed Value (-2000 ~ 2000)	-2000 less	-2000	-1000	0	1000	2000	2000 over
Precise Value (0 ~ 500)	0 less	0	125	250	375	500	500 over
Percentile Value(0 ~ 1000)	0 less	0	250	500	750	1000	1000 over

(5) DC 0 ~ 10V Range Output

Digital Input Range	Analog Output Voltage (V)						
	0V less	0	2.5	5	7.5	10	10V over
Unsigned Value (0 ~ 4000)	0 less	0	1000	2000	3000	4000	4000 over
Signed Value (-2000 ~ 2000)	-2000 less	-2000	-1000	0	1000	2000	2000 over
Precise Value (0 ~ 1000)	0 less	0	250	500	750	1000	1000 over
Percentile Value(0 ~ 1000)	0 less	0	250	500	750	1000	1000 over



## 6.5 Precision

### 6.5.1 Input Precision

The precision of digital output is not dependent upon the input range.

The graph below shows the variation of precision when the analog input range is 0 ~ 10 V for unsigned value for digital output.

The input precision of the XBF-AH04A is  $\pm 0.5\%$ .

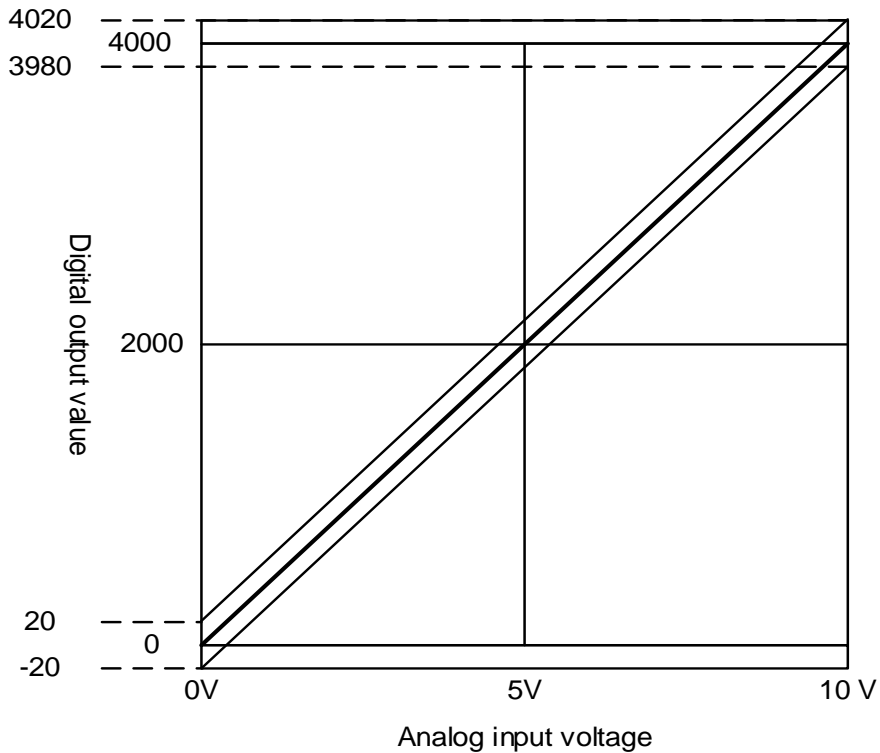

(1) Precision at 5V input;

$$4000 \times 0.5\% = 20$$

Therefore, precision range at 5V input is;  $(2000-20) \sim (2000+20) = 1980 \sim 2020$ .

(2) Precision at 10V input;

$$4000 \times 0.5\% = 20$$

Therefore, precision range at 10V input is;  $(4000-20) \sim (4000+20) = 3980 \sim 4020$ .

### 6.5.2 Output Precision

The precision of analog output is not dependent upon the output range.

The graph below shows the variation of precision when the analog output range is 0 ~ 10 V for unsigned value for digital output.

The output precision of the XBF-AH04A is  $\pm 0.5\%$

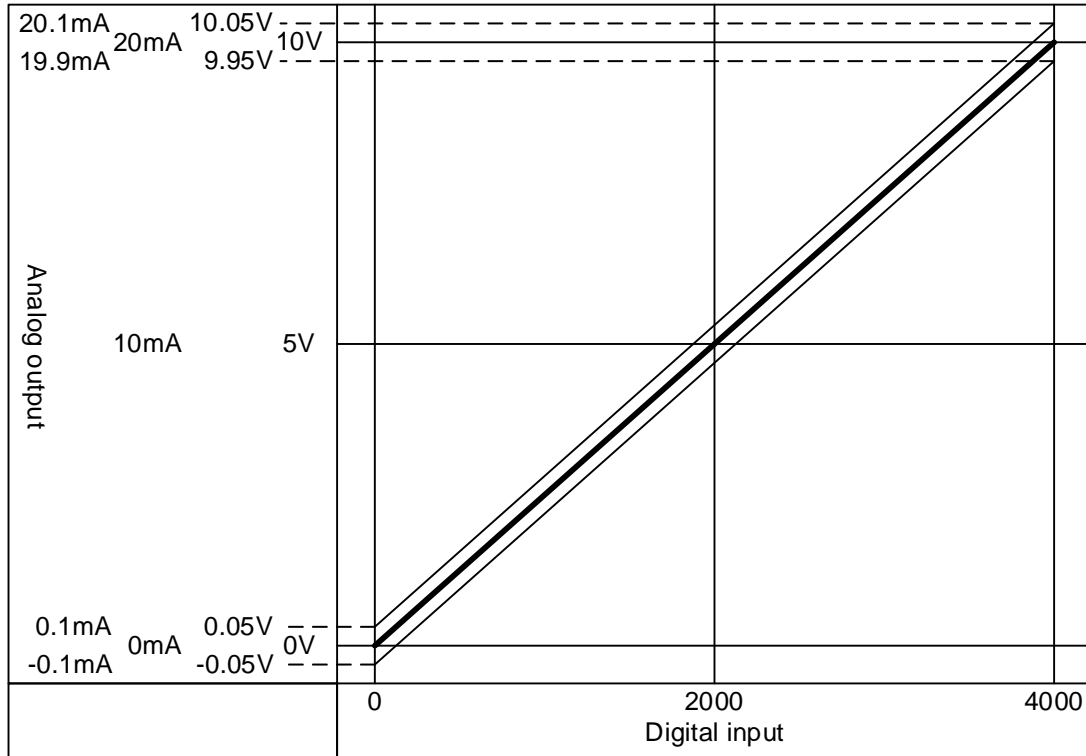

- (1) Precision at 5V output;  
 $4000 \times 0.5\% = 20$ , therefore,  
 precision range at 5V output is;  $(5V - 20 \times 0.0025V) \sim (5V + 20 \times 0.0025V) = 4.95 \sim 5.05V$ .
- (2) Precision at 10V output;  
 $4000 \times 0.5\% = 20$ , therefore,  
 precision range at 10V output is;  $(10V - 20 \times 0.0025V) \sim (5V + 20 \times 0.0025V) = 9.95 \sim 10.05V$ .

## 6.6 Functions of Analog I/O Module

The functions of XBF-AH04A Module are as follows.

Function	Description
Channel operation/stop setting	<ul style="list-style-type: none"> <li>Specify operation/stop of the channel which will perform A/D and D/A conversion.</li> <li>Specifying unused channels as Stop can shorten overall operation time.</li> </ul>
I/O Voltage /current range setting	<ul style="list-style-type: none"> <li>Specify desired range of analog I/O.</li> <li>Select voltage/current with external switch, and set up range with parameter.</li> <li>Analog I/O Module provides 2 ranges(4~20mA, 0~20mA) of current I/O and 3 ranges (1~5V, 0~5V, 0~10V) of voltage I/O.</li> </ul>
I/O data type setting	<ul style="list-style-type: none"> <li>Specify digital I/O types.</li> <li>This module provides 4 output data types (Unsigned, Signed, Precision, and Percentile Values)</li> </ul>
A/D input conversion method	<ul style="list-style-type: none"> <li>Sampling Process               <ul style="list-style-type: none"> <li>If A/D conversion method has not been specified, the module processes sampling.</li> </ul> </li> <li>Filter process               <ul style="list-style-type: none"> <li>Filters rapid changes in input value by external noise.</li> </ul> </li> <li>Averaging process               <ul style="list-style-type: none"> <li>Outputs A/D converted value averaged by time, cycle, and moving.</li> </ul> </li> </ul>
D/A output status setting	<ul style="list-style-type: none"> <li>Sets up channel output state at transition from run to stop.</li> <li>Provides 4 output selections (Previous, Minimum, Mean, Maximum Values)</li> </ul>

### 6.6.1 Sampling Process

In popular A/D conversion process, analog input signals are collected at constant time intervals and A/D converted. The time elapsed for the analog signals converted into digital signals and saved in memory device depends upon the number of channels used.

$$(\text{Process Time}) = (\text{No. of Channels Used}) \times (\text{Conversion Rate})$$

(Ex.) Process time when using 3 of 4 I/O channels;

$$3 \times 1 \text{ ms} = 3.0 \text{ ms}$$

The term 'sampling' means taking analog signal values at certain time intervals.

### 6.6.2 Filtering Function

The input value of the designated channel is calculated with previously filtered input value using preset filter constant (time constant 63.2%) by the formula below;

$$PresentlyFilteredInput = \frac{(PreviouslyFilteredInput \times FilterConstant) + (PresentInput \times 1ms \times No.ofChannelsUsed)}{FilterConstant + (1ms \times No.ofChannelsUsed)}$$

Filter Constant setting range = 4 ~ 64000 [ms]

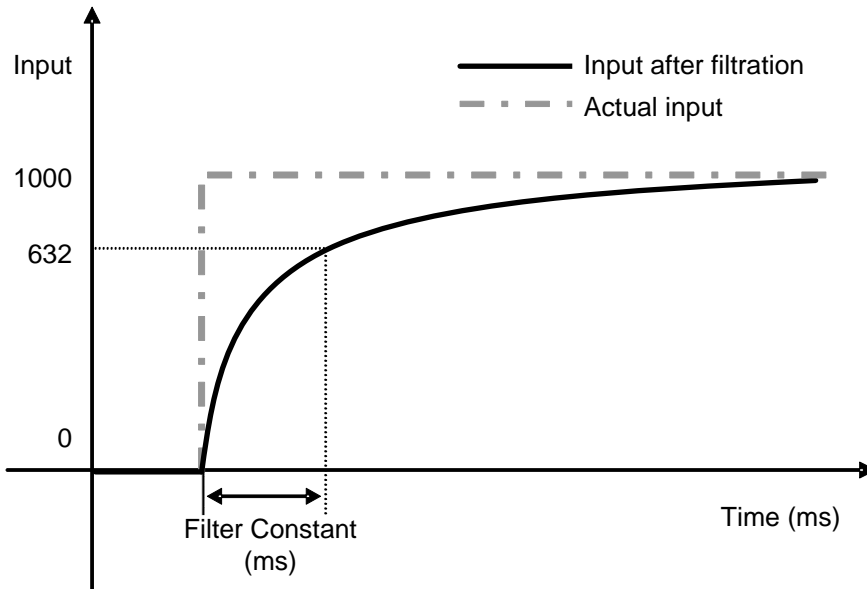

In the above graph, if the input value changes rapidly from 0 to 100, the input value is filtered. Filter (time) constant is the time required for input values to vary by 63.2% of the actual input value.

### 6.6.3 Averaging Function

(1) Average by Time

The input values of the designated channel are accumulated for the preset time, and the average value of the total sum is outputted in digital data.

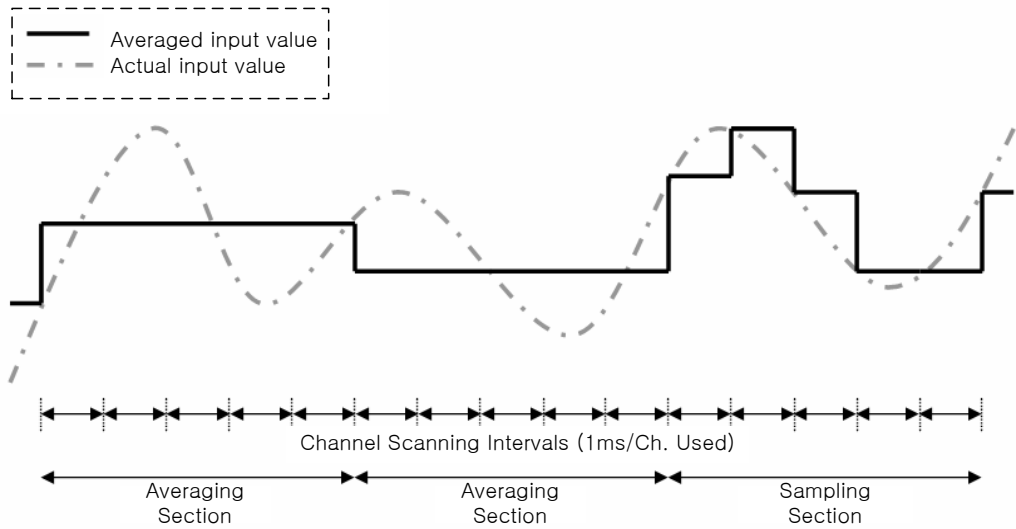

Setting Range = 4 ~ 16000 [ms]

For time averaging, No. of averaging cycles are calculated with the No. of channels used as below;

$$\text{No. Averaging Cycles} = \frac{\text{AverageTime}}{\text{No.ofChannelsUsed} \times 1\text{ms}}$$

(2) Average by Cycles

The input values of the designated channel are accumulated for the preset cycles, and the average value of the total sum is outputted in digital data.

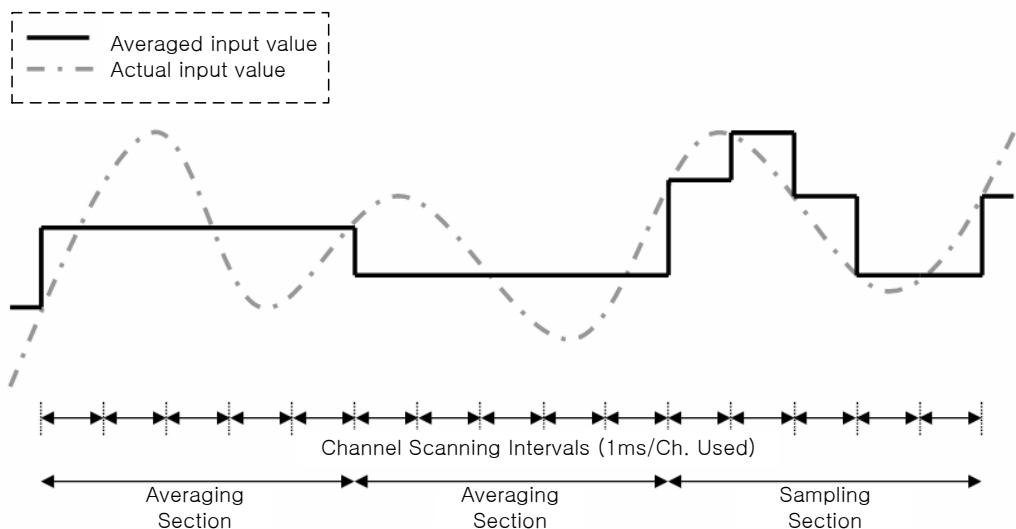

Setting Range = 2 ~ 64000 [Cycle]

For cycle averaging, averaging interval is calculated with the No. of channels used.

$$\text{AveragingInterval [ms]} = \text{AveragingCycle} \times \text{No.ofChannelsUsed} \times 1\text{ms}$$

(3) Moving Average

The inputs into the designated channel are accumulated for the preser number, and its average is calculated and outputted in digital data. However, in moving average method, each scan provides its average value.

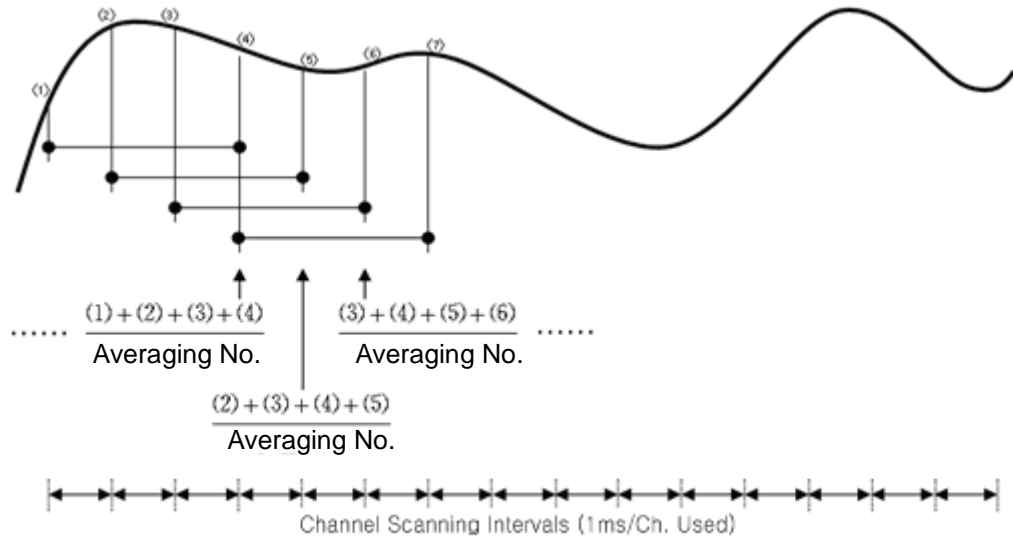

**Note**

- (1) In case of time/cycle averages. The input value is not outputted at every conversion, but the previous value is maintained until the average time or cycle is reached.
- (2) In case of moving averages, the converted input is averaged with the previously entered value and the result is outputted at every conversion. Therefore, data response is faster than time/cycle averaging methods.
- (3) The three averaging methods can be processed simultaneously with the filter function described earlier. In such case, the filter function is executed first, and averaging function is processed to output the average value in digital data, which is expressed with the finally-processed value.

### 6.6.4 Line Open Detection Function

The analog I/O module has a diagnostic function which can detect and indicate open input line, when voltage input range of DC 1~5V or current input range of DC 4~20mA is selected as its analog input range. If the module indicates open input line, check the wiring.

- (1) If the wiring to the module is open, the Input LED flickers at 1 second intervals and the respective error code is generated.
- (2) Line open detection is available for each channel. However, open indication is provided only for the channel selected for the operation. The Input LED is common for the input channels 0 and 1, and flickering if 1 or more channels are open.

Input Connection	Channel Operation	Input LED State	Open Line Flag
Normal	Working	On	Off
	Stopped	On	Off
Input wire open or disconnected	Working	Flickering (1s)	On
	Stopped	On	Off

- (3) At line open, the line open flag of the channel turns On, and turns Off at correction.

Open Flag	Description
U0x.01.4	Ch 0 open
U0x.01.5	Ch 1 open

- (4) At line open, the least of all input values is indicated.

### 6.6.5 Channel Output Status Setting Function

This function sets up the output in response to PLC shutdown or failure.

(1) Function

This function is used to obtain preset output value of the analog I/O module when the PLC system is transferred from run to stop.

(2) Type

Channel output can be one of the followings;

- (a) Previous value: maintains the last output from normal operation.
- (b) Minimum: outputs the least values of the respective output ranges.
- (c) Median: outputs the median values of the respective output ranges.
- (d) Maximum: outputs the largest values of the respective output ranges.

(3) Example

Assume that the output channel range is set to 4 ~ 20mA and the output level is 10mA. If the PLC system is switched from run to stop status, the output will be one of followings according to the setting;

- (a) Previous value: maintains 10mA which is the previous normal operation value.
- (b) Minimum: outputs 4mA which is the minimum of the output range setting.
- (c) Median: outputs 12mA which is the median of the output range setting.
- (d) Maximum: outputs 20mA which is the maximum of the output range setting.



## 6.7 Wiring

### 6.7.1 Precautions for Wiring

- (1) Keep the I/O signal lines of the analog I/O module away from AC power line. Otherwise, the surge or induction noise of the AC line may affect the module.
- (2) The cable should be selected taking ambient temperature and allowable current into consideration. Recommended cable is AWG22 (0.3mm<sup>2</sup>) or higher grade.
- (3) Keep the cables away from heat source or oil. Otherwise, short-circuit, damage, or malfunction of the module may occur.
- (4) Check polarity at terminal block connection.
- (5) Keep the cables away from high voltage line or power line to avoid malfunction or failure of the module by induction.

### 6.7.2 Exemplary Analog Input Wiring

- (1) Input resistance of the current input circuit is 250  $\Omega$  (typ.).
- (2) Input resistance of the voltage input circuit is 1 M $\Omega$  (min.).
- (3) Set only the channels to be used up for operation.
- (4) Analog I/O module does not provide power supply to external input device. Use external power supply.
- (5) Exemplary analog input wiring  
Same wiring scheme is applied to voltage and current inputs, except that voltage/current setting switch must be set up accordingly.

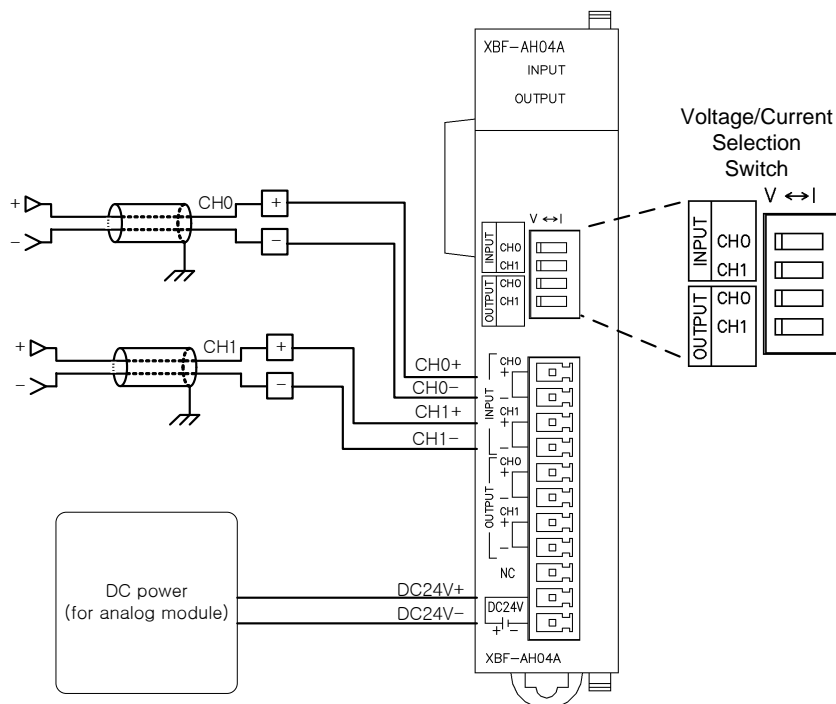

(6) Exemplary Wiring for Analog Input 2-Wire Sensor/Transmission

Same wiring scheme is applied to voltage and current inputs, except that voltage/current setting switch must be set up accordingly.

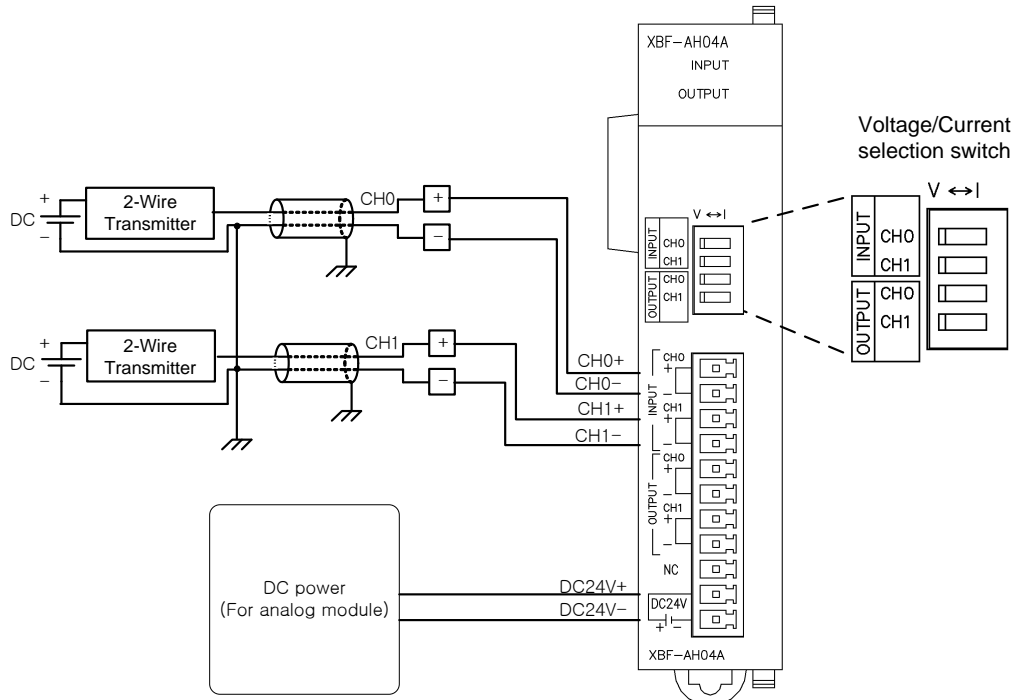

(7) Exemplary Wiring for Analog Input 4-Wire Sensor/Transmission

Same wiring scheme is applied to voltage and current inputs, except that voltage/current setting switch must be set up accordingly.

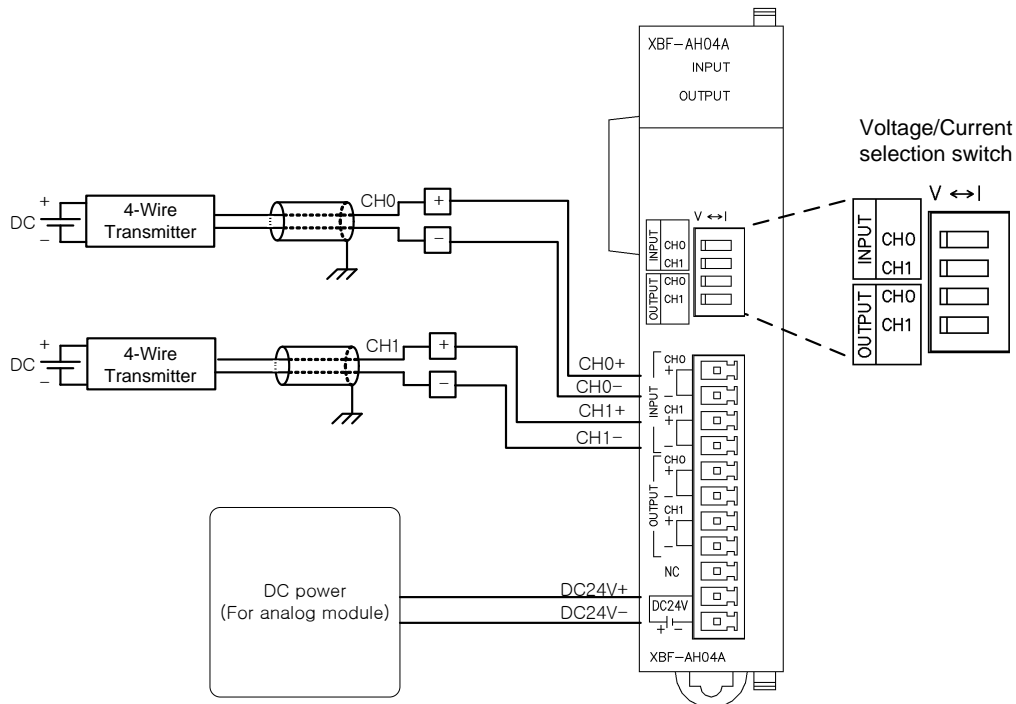

## (8) Relation between voltage input precision and cable length

In voltage input system, the cable length between the module and transmitter or sensor influences on the converted digital value of the module. The value is as follows.

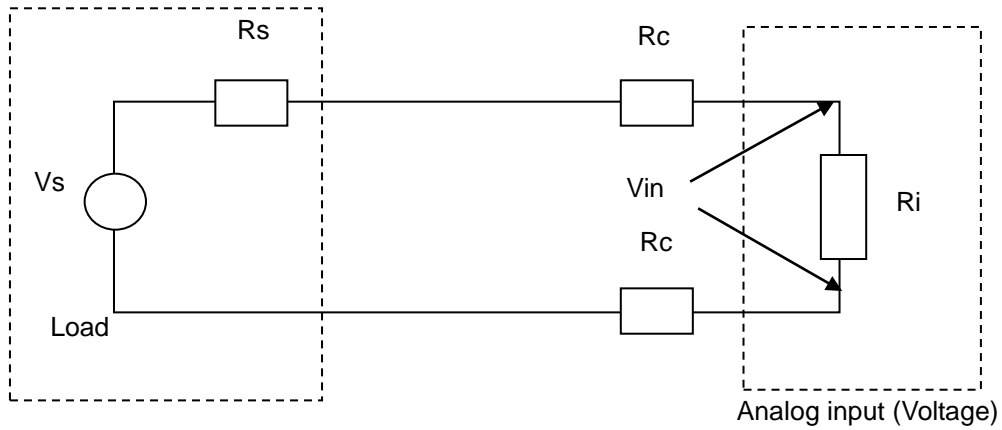

Where,

$R_c$ : line resistance of the wire,

$R_s$ : internal resistance of the transmitter or sensor,

$R_i$ : internal resistance of voltage input module ( $1 \text{ M}\Omega$ )

$V_{in}$ : voltage applied to the analog input

%  $V_i$ : error in the converted value caused by source and cable length in voltage input(%)

$$V_{in} = \frac{R_i \times V_s}{[R_s + (2 \times R_c) + R_i]}$$

$$\% V_i = \left(1 - \frac{V_{in}}{V_s}\right) \times 100\%$$

### 6.7.3 Exemplary Analog Output Wiring

(1) Exemplary analog voltage output wiring

Same wiring scheme is applied to voltage and current outputs, except that voltage/current setting switch must be set up accordingly.

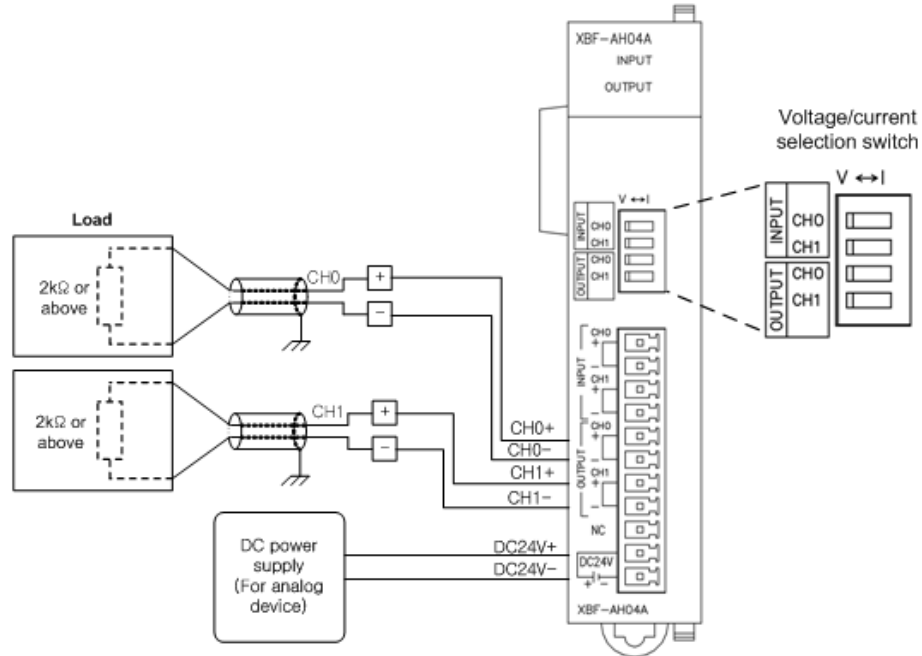

(2) Exemplary analog current output wiring

Same wiring scheme is applied to voltage and current outputs, except that voltage/current setting switch must be set up accordingly.

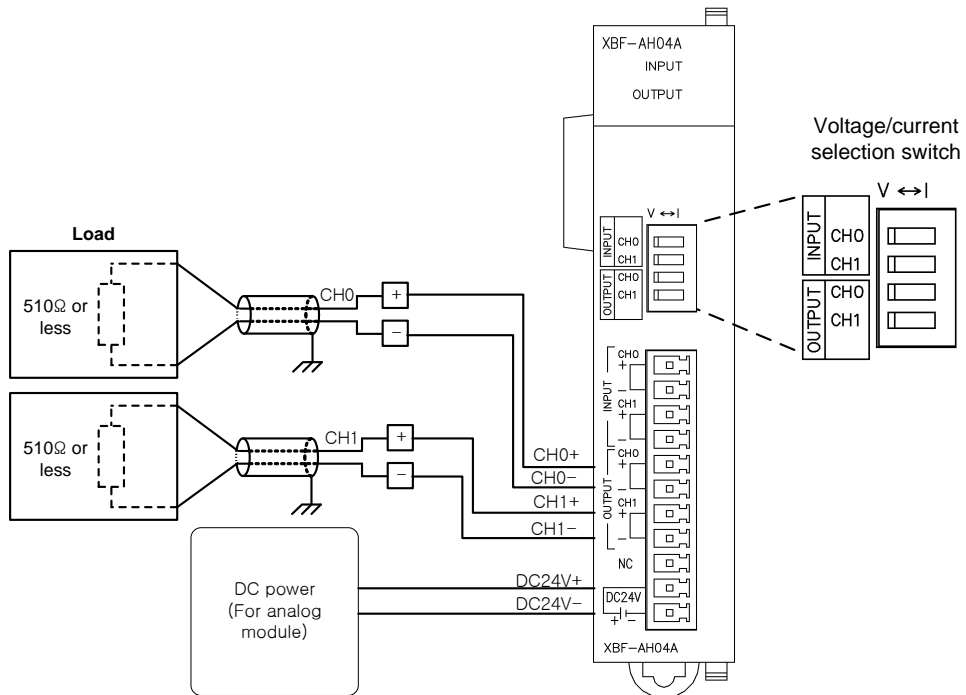

## 6.8 Operation Parameter Setting

The operation parameters of analog I/O module can be set up with XG5000 [I/O Parameter].

### (1) Setting Items

For user convenience, XG5000 provides GUI (graphic user interface) for analog I/O module parameter setting. The items which can be set up in the [I/O Parameter] in the XG5000 project window are as follows.

Item	Description
[I/O Parameter]	(a) Input parameter setting Sets up following items required for module operation. 1) Operation channel (Stop/Run) 2) Input voltage (current) range 3) Output data type 4) Filter constant 5) averaging process 6) Average value (b) Output parameter setting Sets up following items required for module operation. 1) Operation channel (Stop/Run) 2) Output voltage (current) range 3) Input data type 4) Channel output status (c) The parameters set up in XG5000, when downloaded, are stored in the flash memory of the XGB base unit.

### (2) Usage of [I/O Parameter]

- (a) Create a project with XG5000. See XG5000 Program Manual for project creation.
- (b) In the Project window, double-click [I/O Parameter].

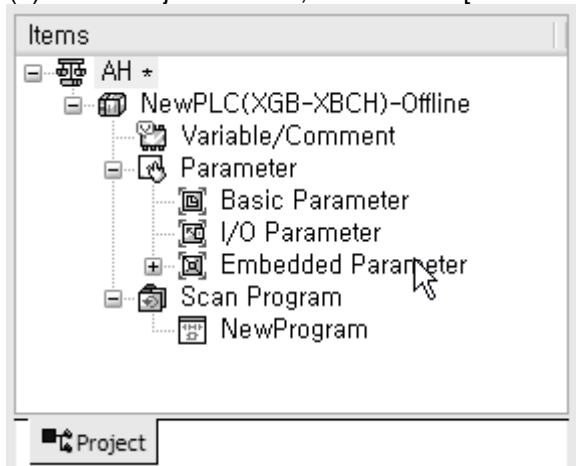

(c) In the [I/O Parameter Setting] window, find out the slot of the base where the analog I/O module is installed, and click it.

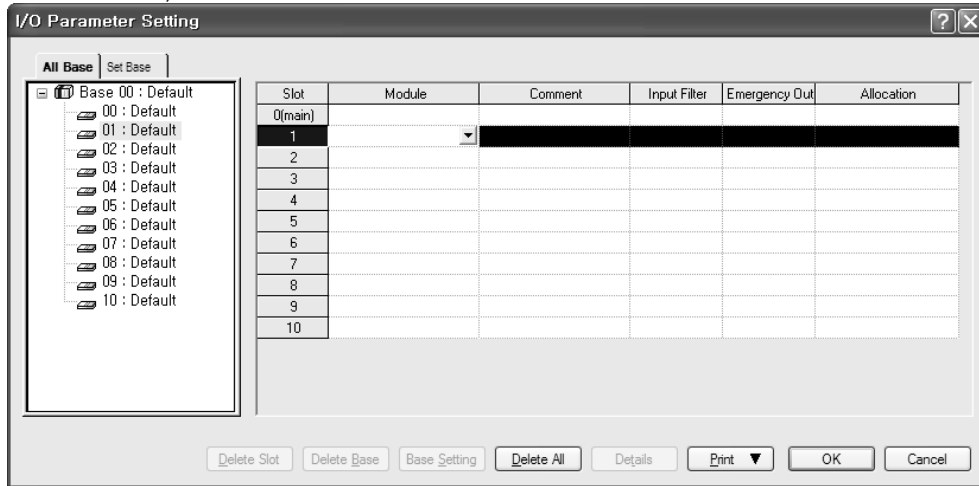

(d) In the above window, click the arrow button to call the window where the module can be selected. Find out the module and select it.

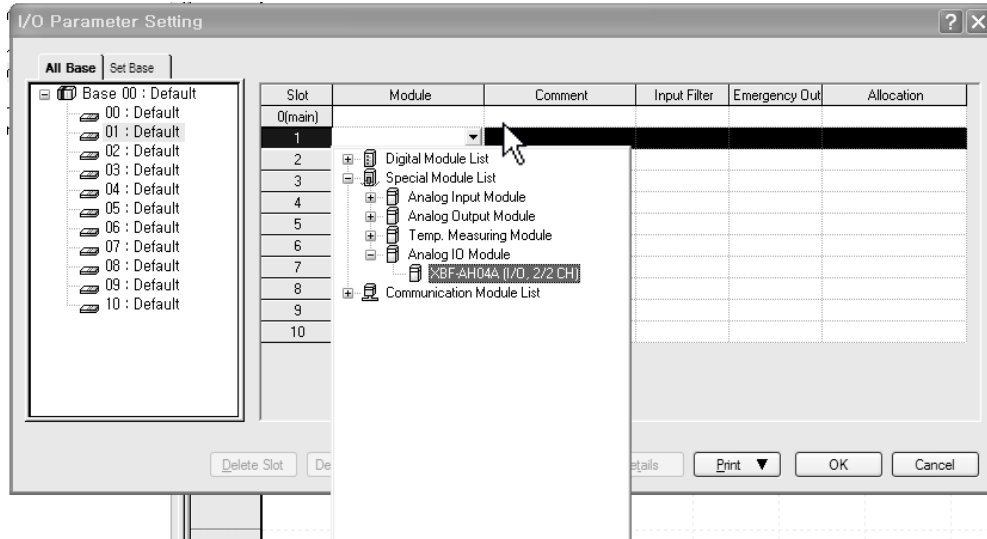

(e) To set up parameter, double click with the respective slot being selected, or click [Detail] button.

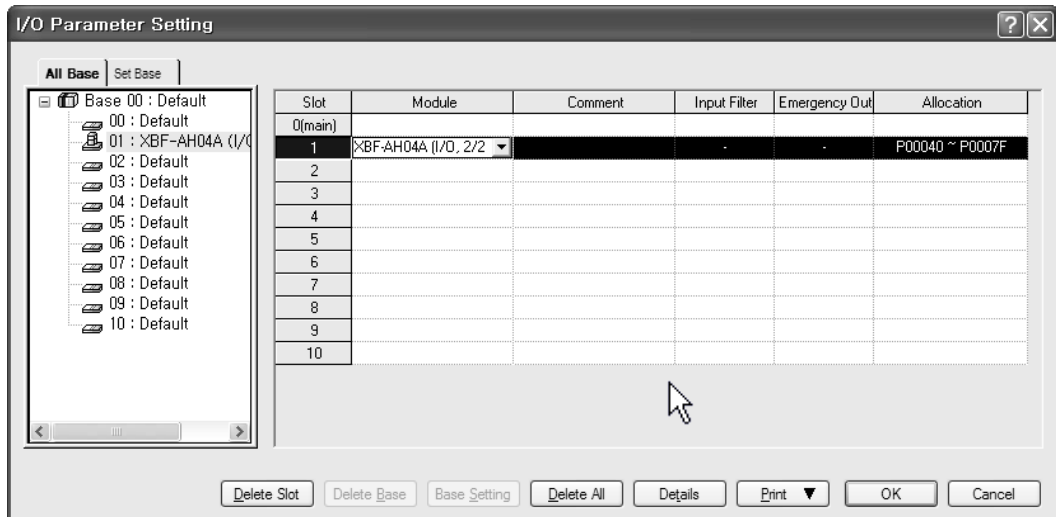

(f) The window below where parameters can be set up by channel appears. Click the item to set up. The parameters which can be set up appear by item.

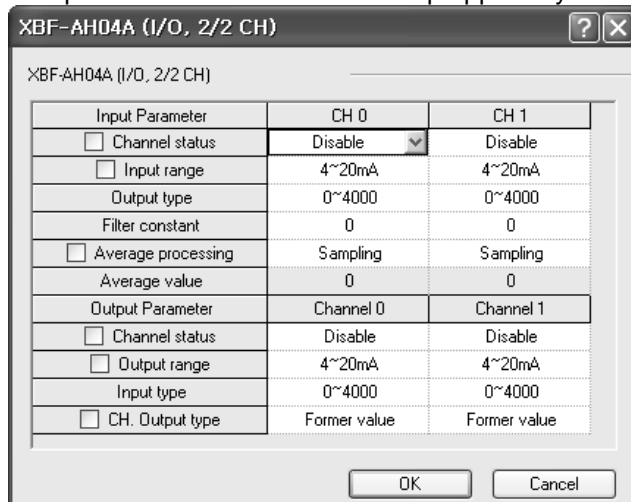

## 6.9 Special Module Monitor Function

The functions of the special module monitor are as follows.

### (1) Start-up of [Special Module Monitor]

Select [Online] -> [Connect], and [Monitor] -> [Special Module Monitor] to start up. [Special Module Monitor] menu is enabled only in the [Online] condition.

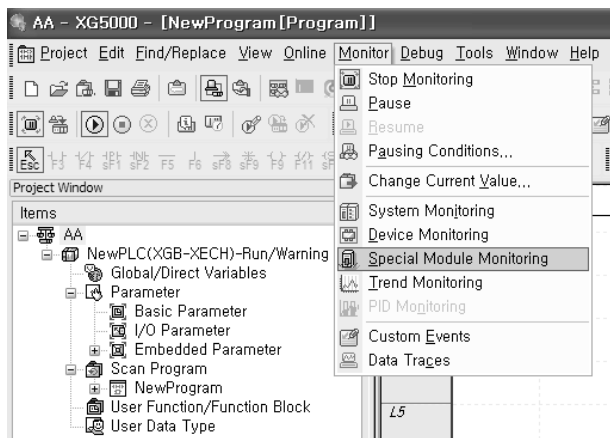

### Note

- 1) The screen may not function properly if the system resources are not sufficient. In this case, close the screen, exit other applications, and rerun XG5000.
- 2) The I/O parameters set up in [Special Module Monitor] condition are temporarily set up for testing purpose. Therefore, these I/O parameters are deleted after exit from [Special Module Monitor].
- 3) the test function of the [Special Module Monitor] enables testing analog I/O modules without sequence programming.

(2) Usage of [Special Module Monitor]

(a) With the XG5000 in connection (online) with the base unit of PLC, select [Monitor] -> [Special Module Monitor]. The Select Special Module window shown below will appear showing the type of the special modules and base/slot information. In the list dialog, the modules present in the PLC system are displayed.

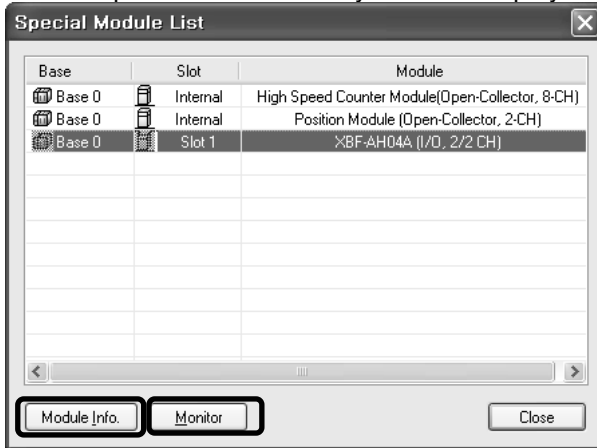

(b) In the above window, select the special module and click [Module Info.] to see the information window below.

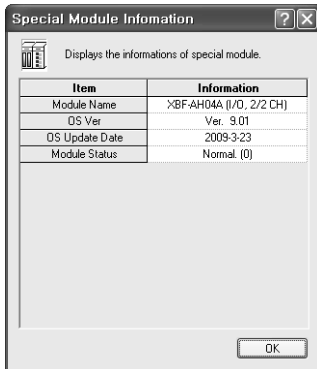

(c) Click the [Monitor] button in the “Special Module” window. The “Special Module Monitor” window will appear as shown below.

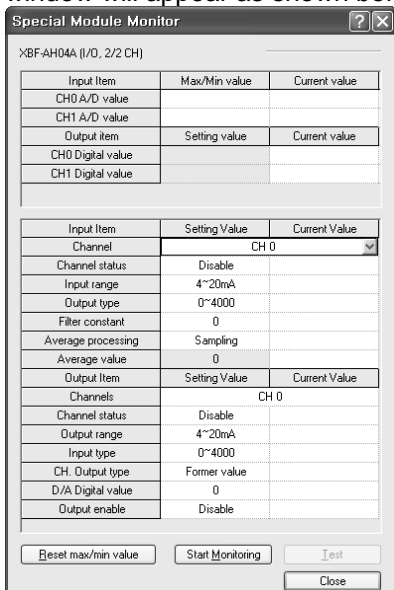



- (d) [Start Monitoring]: click [Start Monitoring] to look up the digital input data of the channel currently in operation. The screen shot below is a monitoring window when all the channels are in operation status.

**Special Module Monitor**

XBF-AH04A (I/O, 2/2 CH)

Input Item	Max/Min value	Current value
CH0 A/D value	0 / 0	0
CH1 A/D value	0 / 0	0
Output item	Setting value	Current value
CH0 Digital value		0
CH1 Digital value		0

Input Item	Setting Value	Current Value
Channel	CH 0	
Channel status	Disable	Disable
Input range	4~20mA	4~20mA
Output type	0~4000	0~4000
Filter constant	0	0
Average processing	Sampling	Sampling
Average value	0	0
Output Item	Setting Value	Current Value
Channels	CH 0	
Channel status	Disable	Disable
Output range	4~20mA	4~20mA
Input type	0~4000	0~4000
CH Output type	Former value	Former value
D/A Digital value	0	0
Output enable	Disable	Disable

Buttons:

The screen executing [Start Monitoring]

- (e) [Test]: this function is used to change the current parameter settings of the analog I/O module. Click the settings in the fields in the bottom screen to change the parameters. [Test] can be set up only when the operation status of the XGB base unit is STOP.

**Special Module Monitor**

XBF-AH04A (I/O, 2/2 CH)

Input Item	Max/Min value	Current value
CH0 A/D value	0 / 0	0
CH1 A/D value	0 / 0	0
Output item	Setting value	Current value
CH0 Digital value		0
CH1 Digital value		0

Input Item	Setting Value	Current Value
Channel	CH 0	
Channel status	Enable	Enable
Input range	4~20mA	4~20mA
Output type	0~4000	0~4000
Filter constant	0	0
Average processing	Sampling	Sampling
Average value	0	0
Output Item	Setting Value	Current Value
Channels	CH 0	
Channel status	Enable	Enable
Output range	4~20mA	4~20mA
Input type	0~4000	0~4000
CH Output type	Former value	Former value
D/A Digital value	0	0
Output enable	Disable	Disable

Buttons:

The screen executing [Test]

(f) Minimum/Maximum Value Monitoring

The minimum and maximum values of the input channels in operation can be monitored. However, the Max/Min values in the window are based on the current value. Therefore, the Max/Min values are not saved when exiting from the [Monitoring/Testing Screen].

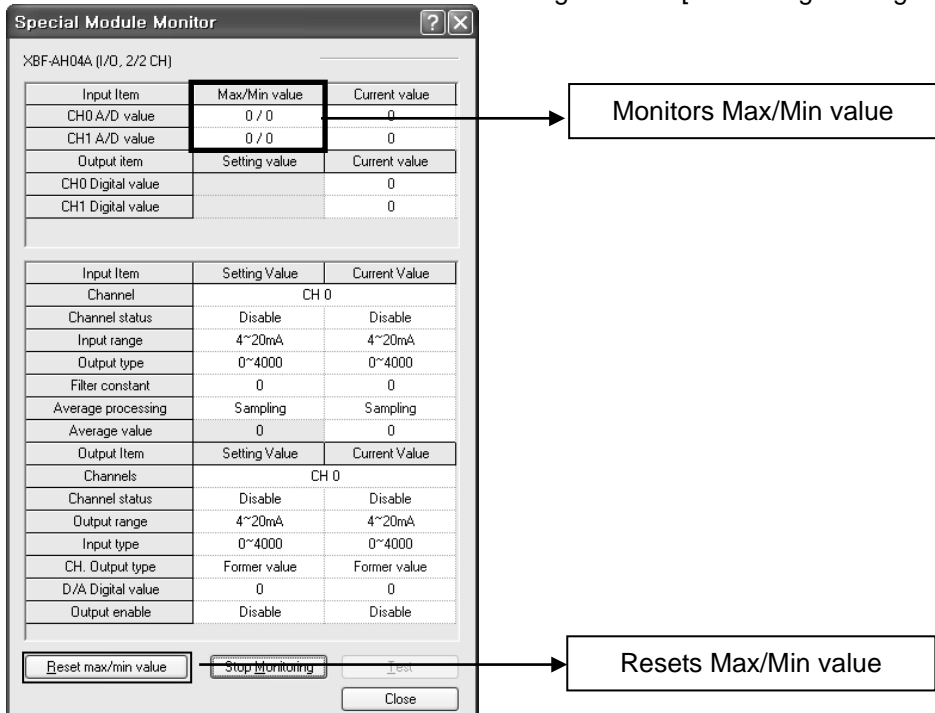

The screen executing [Max/Min Value Monitoring]

(g) Close

[Close] button is for ending/closing the monitoring/testing screen. Maximum, minimum, and current values are not saved at exit.

## 6.10 Auto-registration of U-Device (Special Module Variable)

The variables for each module are automatically registered by referring to the information of the special modules set up in the [I/O Parameter]. User can modify variables and descriptions.

(1) Registration Procedure

(a) In [I/O Parameter], set up special module in slot.

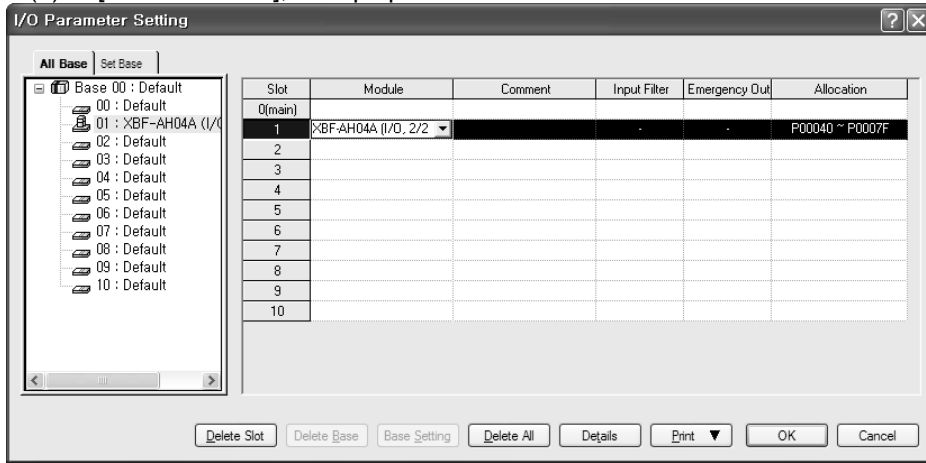

(b) Double click [Variables/Comment].

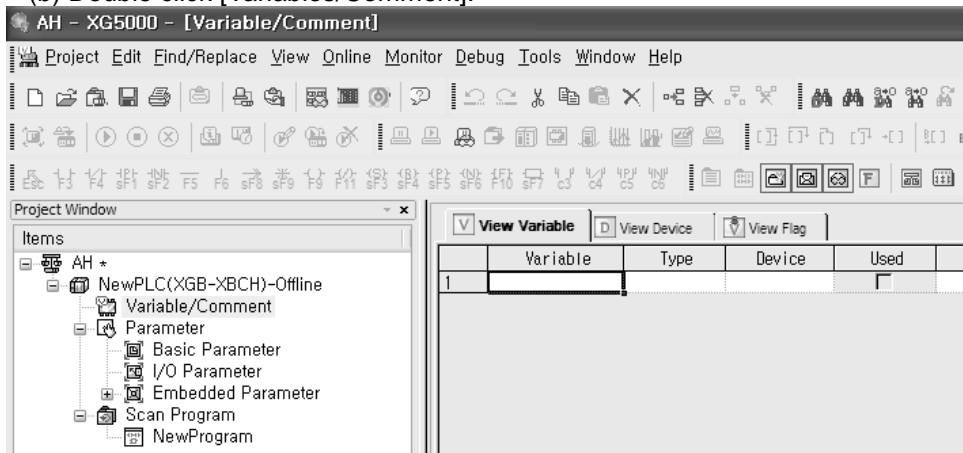

(c) In the 'Edit' menu, select 'U-Device Auto Registration' (special module variable auto registration).

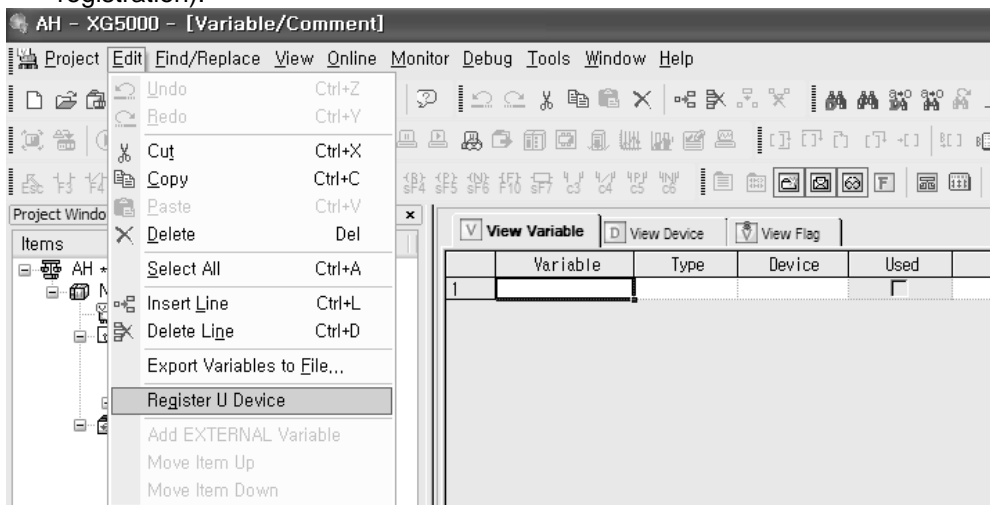

(d) Click 'Yes.'



(e) Variables are registered as shown below.

View Variable View Device View Flag					
	Variable	Type	Device	Used	Comment
1	_01_ERR	BIT	U01.00.0	<input type="checkbox"/>	Analog IO Module: Module Error
2	_01_RDY	BIT	U01.00.F	<input type="checkbox"/>	Analog IO Module: Module Ready
3	_01_ADDO_ACT	BIT	U01.01.0	<input type="checkbox"/>	Analog IO Module: Input CH0 Active
4	_01_AD1_ACT	BIT	U01.01.1	<input type="checkbox"/>	Analog IO Module: Input CH1 Active
5	_01_DAO_ACT	BIT	U01.01.2	<input type="checkbox"/>	Analog IO Module: Output CH0 Active
6	_01_DA1_ACT	BIT	U01.01.3	<input type="checkbox"/>	Analog IO Module: Output CH1 Active
7	_01_ADDO_IDD	BIT	U01.01.4	<input type="checkbox"/>	Analog IO Module: Input CH0 Disconnection Flag
8	_01_AD1_IDD	BIT	U01.01.5	<input type="checkbox"/>	Analog IO Module: Input CH1 Disconnection Flag
9	_01_ADDO_ERR	BIT	U01.01.8	<input type="checkbox"/>	Analog IO Module: Input CH0 Error
10	_01_AD1_ERR	BIT	U01.01.9	<input type="checkbox"/>	Analog IO Module: Input CH1 Error
11	_01_DAO_ERR	BIT	U01.01.A	<input type="checkbox"/>	Analog IO Module: Output CH0 Error
12	_01_DA1_ERR	BIT	U01.01.B	<input type="checkbox"/>	Analog IO Module: Output CH1 Error
13	_01_DAO_OUTEN	BIT	U01.06.0	<input type="checkbox"/>	Analog IO Module: Output CH0 Status Setting
14	_01_DA1_OUTEN	BIT	U01.06.1	<input type="checkbox"/>	Analog IO Module: Output CH1 Status Setting
15	_01_ADDO_DATA	WORD	U01.04	<input type="checkbox"/>	Analog IO Module: Input CH0 Data
16	_01_AD1_DATA	WORD	U01.05	<input type="checkbox"/>	Analog IO Module: Input CH1 Data
17	_01_DAO_DATA	WORD	U01.07	<input type="checkbox"/>	Analog IO Module: Output CH0 DATA
18	_01_DA1_DATA	WORD	U01.08	<input type="checkbox"/>	Analog IO Module: Output CH1 DATA

(f) In IEC types, the variables are registered as shown below.

Global Variable Direct Variable Comment Flag								
	Variable Kind	Variable	Type	Address	Initial Value	Retain	Used	Comment
2	VAR_GLOBAL	_01_ADDO_DATA	WORD	\$XUW0.1.4		<input type="checkbox"/>	<input type="checkbox"/>	Analog IO Module: Input CH0 Data
3	VAR_GLOBAL	_01_ADDO_ERR	BOOL	\$XUX0.1.24		<input type="checkbox"/>	<input type="checkbox"/>	Analog IO Module: Input CH0 Error
4	VAR_GLOBAL	_01_ADDO_IDD	BOOL	\$XUX0.1.20		<input type="checkbox"/>	<input type="checkbox"/>	Analog IO Module: Input CH0 Disconnection
5	VAR_GLOBAL	_01_AD1_ACT	BOOL	\$XUX0.1.17		<input type="checkbox"/>	<input type="checkbox"/>	Analog IO Module: Input CH1 Active
6	VAR_GLOBAL	_01_AD1_DATA	WORD	\$XUW0.1.5		<input type="checkbox"/>	<input type="checkbox"/>	Analog IO Module: Input CH1 Data
7	VAR_GLOBAL	_01_AD1_ERR	BOOL	\$XUX0.1.25		<input type="checkbox"/>	<input type="checkbox"/>	Analog IO Module: Input CH1 Error
8	VAR_GLOBAL	_01_AD1_IDD	BOOL	\$XUX0.1.21		<input type="checkbox"/>	<input type="checkbox"/>	Analog IO Module: Input CH1 Disconnection
9	VAR_GLOBAL	_01_DAO_ACT	BOOL	\$XUX0.1.18		<input type="checkbox"/>	<input type="checkbox"/>	Analog IO Module: Output CH0 Active
10	VAR_GLOBAL	_01_DAO_DATA	WORD	\$XUW0.1.7		<input type="checkbox"/>	<input type="checkbox"/>	Analog IO Module: Output CH0 DATA
11	VAR_GLOBAL	_01_DAO_ERR	BOOL	\$XUX0.1.26		<input type="checkbox"/>	<input type="checkbox"/>	Analog IO Module: Output CH0 Error
12	VAR_GLOBAL	_01_DAO_OUTEN	BOOL	\$XUX0.1.96		<input type="checkbox"/>	<input type="checkbox"/>	Analog IO Module: Output CH0 Status Setti
13	VAR_GLOBAL	_01_DA1_ACT	BOOL	\$XUX0.1.19		<input type="checkbox"/>	<input type="checkbox"/>	Analog IO Module: Output CH1 Active
14	VAR_GLOBAL	_01_DA1_DATA	WORD	\$XUW0.1.8		<input type="checkbox"/>	<input type="checkbox"/>	Analog IO Module: Output CH1 DATA
15	VAR_GLOBAL	_01_DA1_ERR	BOOL	\$XUX0.1.27		<input type="checkbox"/>	<input type="checkbox"/>	Analog IO Module: Output CH1 Error
16	VAR_GLOBAL	_01_DA1_OUTEN	BOOL	\$XUX0.1.97		<input type="checkbox"/>	<input type="checkbox"/>	Analog IO Module: Output CH1 Status Setti
17	VAR_GLOBAL	_01_ERR	BOOL	\$XUX0.1.0		<input type="checkbox"/>	<input type="checkbox"/>	Analog IO Module: Module Error
18	VAR_GLOBAL	_01_RDY	BOOL	\$XUX0.1.15		<input type="checkbox"/>	<input type="checkbox"/>	Analog IO Module: Module Ready
19						<input type="checkbox"/>	<input type="checkbox"/>	

(2) Saving Variables

- (a) The contents in the 'View Variables' tab can be saved in a text file.
- (b) In the 'Edit' menu, select 'Save as Text File.'
- (c) The contents in the 'View Variables' tab are saved in a text file.

(3) Viewing Variables in Program

The figures below present examples of use in XGB “S” and “H” types.

(a) Below is an exemplary program for XG5000.

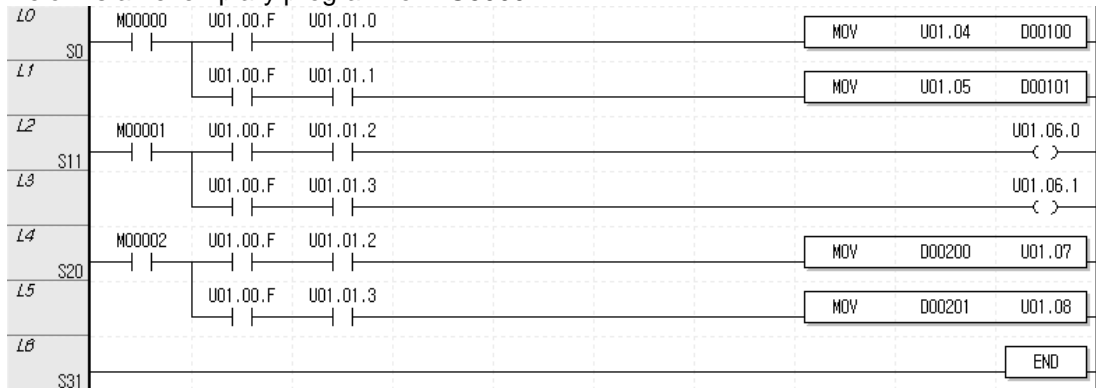

(b) In the 'View' menu, click 'View Variables.' The devices are changed into variables.

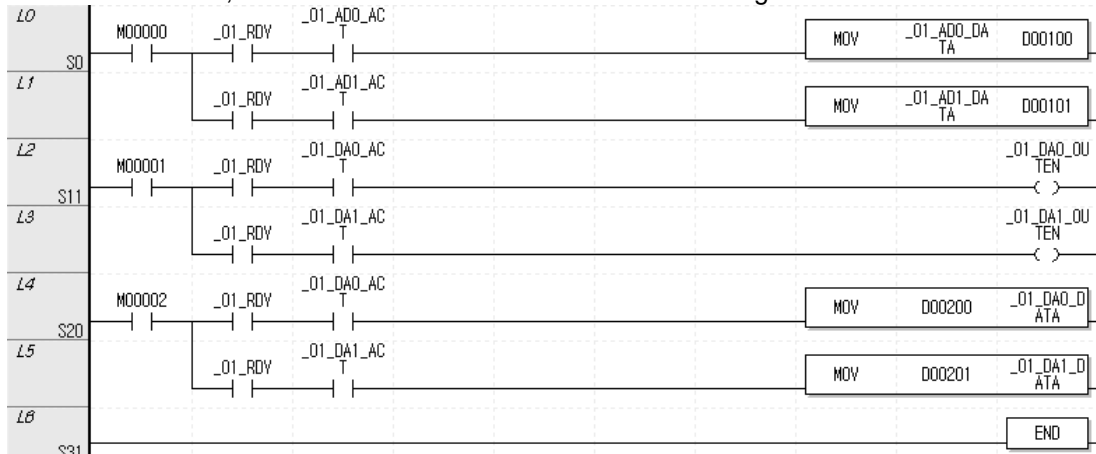

(c) In the 'View' menu, click 'View Device/Variables' to look up the devices and variables at the same time.

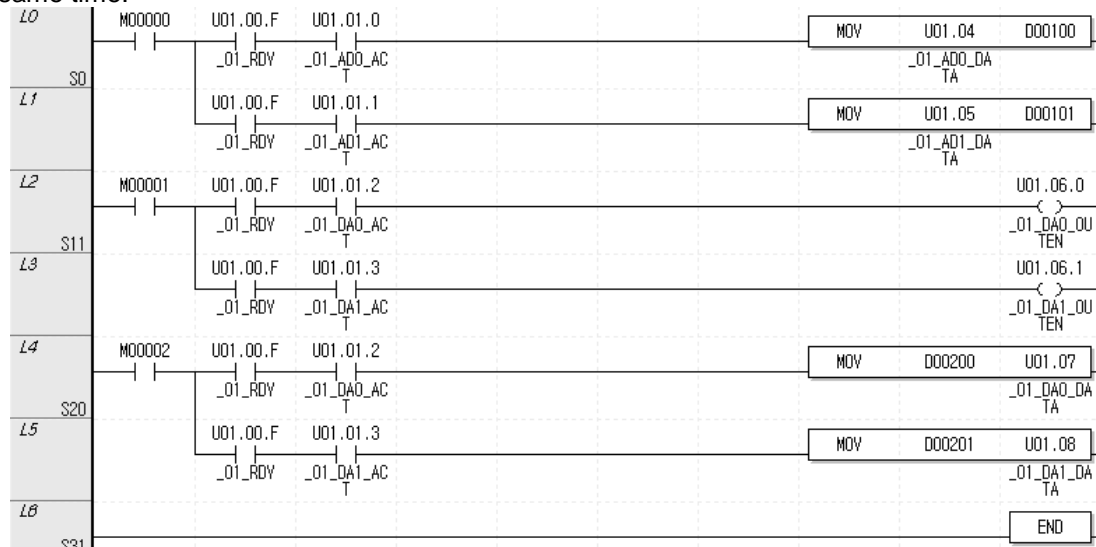

(d) In the 'View' menu, click 'View Device/Description' to look up the devices and descriptions at the same time.

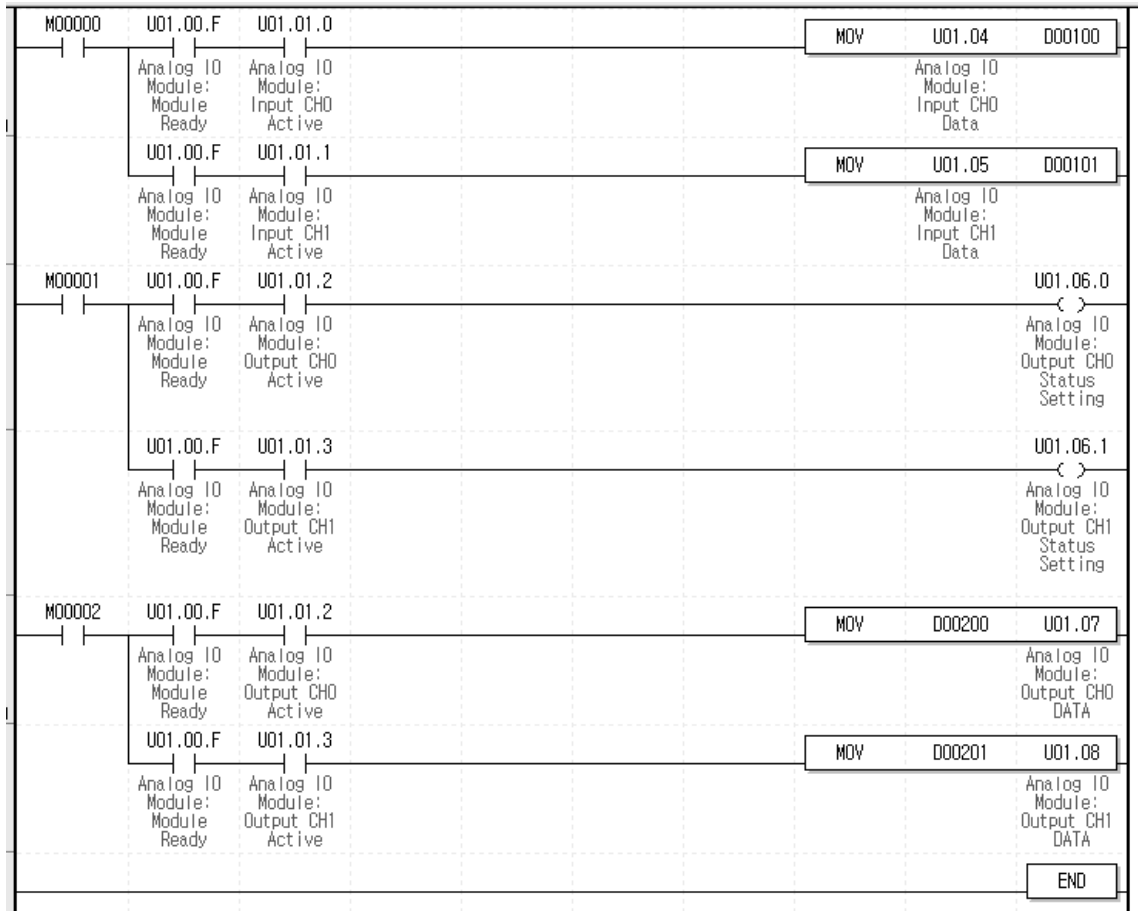

(e) For IEC type also, as shown in Fig. (a) ~ (d), you can look up variables with diversified options in the 'View' menu. The figure below is the case of an IEC type with which the 'View Variables/Descriptions' option.

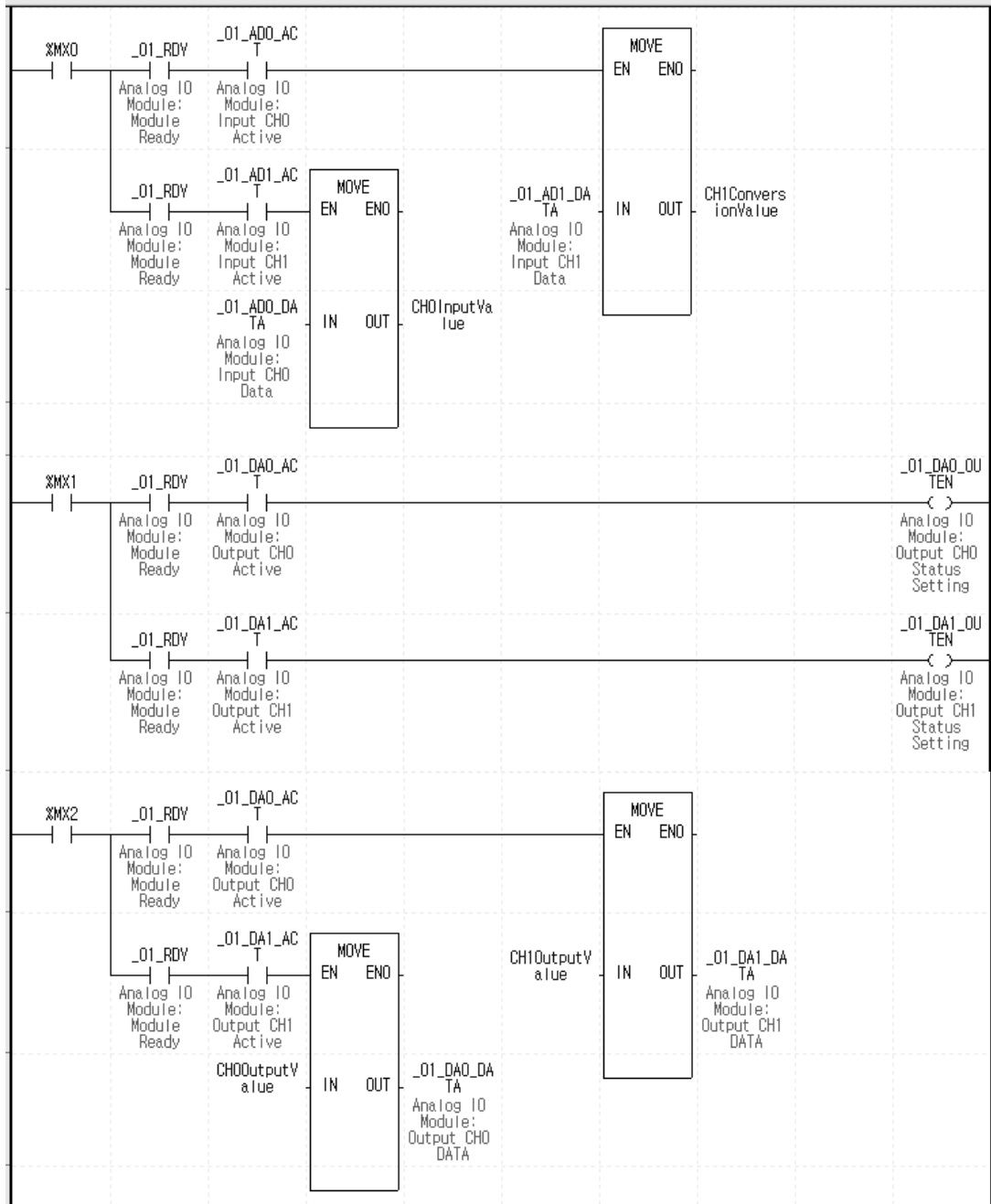

## 6.11 Constitution and Function of Internal Memory

An analog I/O module has internal memory for data communication with XGB base unit.

### 6.11.1 Analog Data I/O Area

The table below presents the analog data I/O area.

Variable	Type	Device Allocation		Description	Read/Write	Signal Direction
		“S” or “H” Type	IEC Type			
_0y_ERR	BIT	U0y.00.0	%UX0.y.0	Module error	Read	AH04A → CPU
_0y_RDY	BIT	U0y.00.F	%UX0.y.15	Module ready		
_0y_AD0_ACT	BIT	U0y.01.0	%UX0.y.16	Input Ch 0 operating	Read	AH04A → CPU
_0y_AD1_ACT	BIT	U0y.01.1	%UX0.y.17	Input Ch 1 operating		
_0y_DA0_ACT	BIT	U0y.01.2	%UX0.y.18	Output Ch 0 operating		
_0y_DA1_ACT	BIT	U0y.01.3	%UX0.y.19	Output Ch 1 operating		
_0y_AD0_IDD	BIT	U0y.01.4	%UX0.y.20	Input Ch 0 open wire detected	Read	AH04A → CPU
_0y_AD1_IDD	BIT	U0y.01.5	%UX0.y.21	Input Ch 1 open wire detected		
_0y_AD0_ERR	BIT	U0y.01.8	%UX0.y.24	Input Ch 0 error	Read	AH04A → CPU
_0y_AD1_ERR	BIT	U0y.01.9	%UX0.y.25	Input Ch 1 error		
_0y_DA0_ERR	BIT	U0y.01.A	%UX0.y.26	Output Ch 0 error		
_0y_DA1_ERR	BIT	U0y.01.B	%UX0.y.27	Output Ch 1 error		
_0y_AD0_DATA	WORD	U0y.04	%UW0.y.4	Input Ch 0 converted value	Read	AH04A → CPU
_0y_AD1_DATA	WORD	U0y.05	%UW0.y.5	Input Ch 1 converted value	Read	AH04A → CPU
_0y_DA0_OUTEN	BIT	U0y.06.0	%UX0.y.96	Ch 0 output state setting	Write	AH04A ↔ CPU
_0y_DA1_OUTEN	BIT	U0y.06.1	%UX0.y.97	Ch 1 output state setting		
_0y_DA0_DATA	WORD	U0y.07	%UW0.y.7	Output Ch 0 input value	Write	AH04A ↔ CPU
_0y_DA1_DATA	WORD	U0y.08	%UW0.y.8	Output Ch 1 input value	Write	AH04A ↔ CPU

- In the device allocation, the small letter ‘y’ is the No. of the slot where the module is installed.
- For example, to read the ‘Input Ch 1 Converted Value’ of the analog I/O module installed in the 4<sup>th</sup> slot, write in U04.05. (%UW0.4.5 for IEC types)



- To read the ‘Output Ch 1 Output Status Setting’ of the analog I/O module installed in the 5<sup>th</sup> slot, write in U05.06.1 (%UX0.5.97 for IEC types)

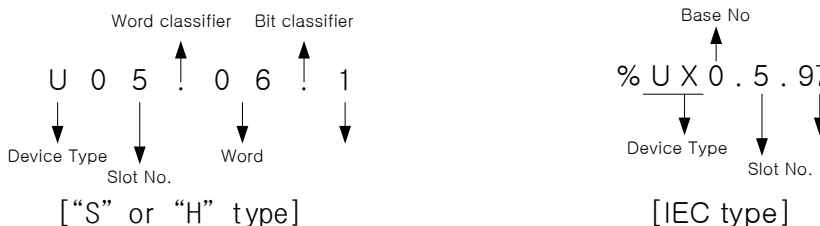



- (1) Module Ready/Error Flag ( ) is for IEC types, x: slot No.)  
 (a) U0x.00.F(%UX0.x.15): at power on or reset of PLC CPU, turns on when the analog I/O conversion is ready and analog conversion is performed.  
 (b) U0x.00.0(%UX0.x.0): the flag indicating the error status of A/D conversion module.

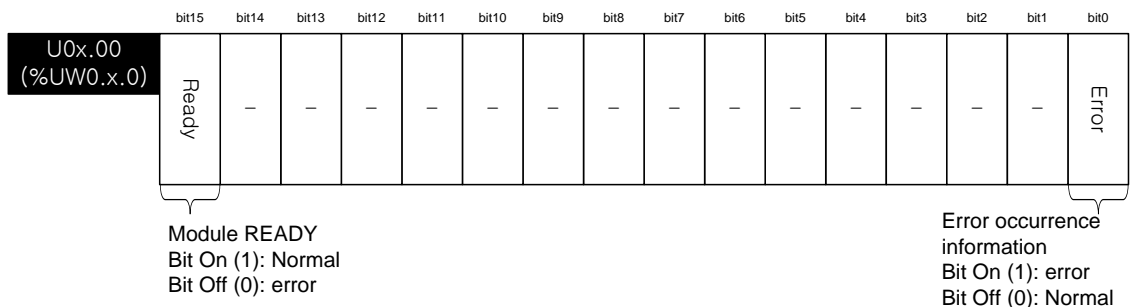

- (2) Operation channel information/ open-wire detection information/ channel error information flags ( ' ) is for IEC types, x: slot No.)  
 This is the area for storing the operation information, input wire open detection and channel error information by channel.  
 ※ The base No. of the XGB PLC is 0.

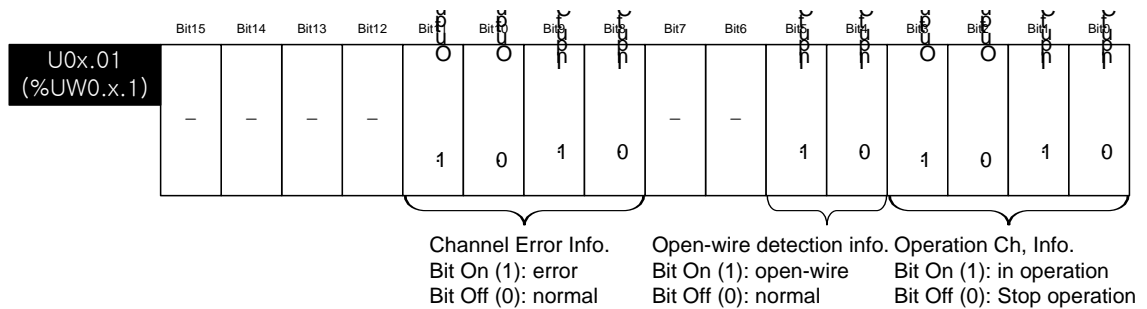

- (3) Digital Output Values ( ) is for IEC types, x: slot No.)  
 (a) A/D converted digital values are outputted to buffer memory address U0x.04 ~ U0x.05 (%UW0.x.4 ~ %UW0.x.5) by channel-basis.  
 (b) Digital output values are saved in 16-bit binary figures.  
 ※ The base No. of the XGB PLC is 0.

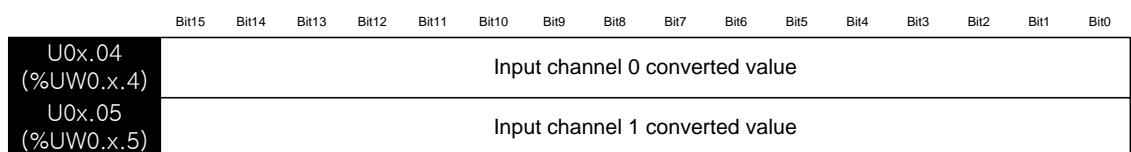

- (4) Output Permit Setting ( ) is for IEC types, x: slot No.)
  - (a) Output permit/prohibit can be set up for each channel.
  - (b) The default setting is 'Output Prohibited.'
  - ※ The base No. of the XGB PLC is 0.

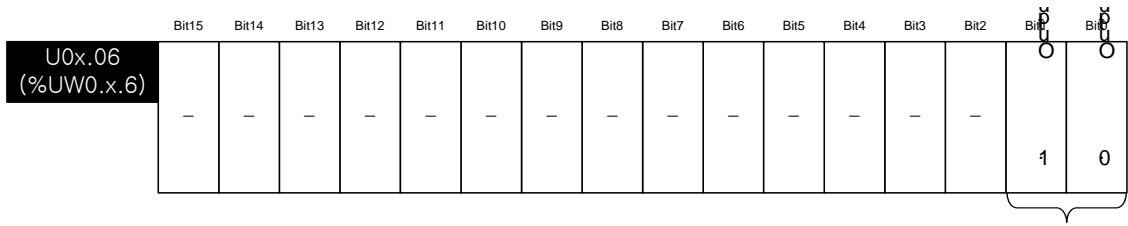

Output status setting  
 BitOn (1): Output permitted  
 BitOff (0): Output prohibited

- (5) Digital Input Values ( ) is for IEC types, x: slot No.)
  - (a) Digital inputs can be set up as unsigned (-48~4047), signed (-2048~2047), precision, or percentile (-12~1011) values.
  - (b) When digital input value is not set up, they are processed as zero.
  - ※ The base No. of the XGB PLC is 0.

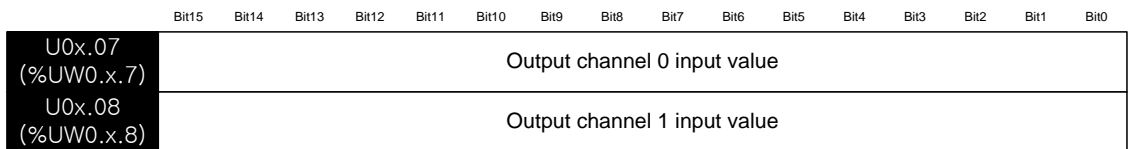

### 6.11.2 Operation Parameter Setting Area

The operation parameter setting area of the analog I/O module is as follows.

Memory Add.	Description	Setting	R/W	Command
0	Appoint operating channel	Bit Off (0): stop, Bit ON (1): run	R/W	PUT/GET
1	I/O range setting	I/O range setting (4 bit per Ch.) 0: 4 ~ 20 mA 1: 0 ~ 20 mA 2: 1 ~ 5 V 3: 0 ~ 5 V 4: 0 ~ 10 V	R/W	
2	I/O data type setting	I/O data type setting (4 bit per Ch.) 0: 0 ~ 4000 1: -2000 ~ 2000 2: Precision value 3: 0 ~ 1000 - for precision values; 4 ~ 20 mA: 400 ~ 2000 0 ~ 20 mA: 0 ~ 2000 1 ~ 5 V: 100 ~ 500 0 ~ 5 V: 0 ~ 500 0 ~ 10 V: 0 ~ 1000	R/W	
3	Input Ch 0 filter value setting	0 or 4 ~ 64000	R/W	
4	Input Ch 1 filter value setting		R/W	
5	Averaging method setting	Averaging method setting (4 bit per Ch.) 0: Sampling 1: Time average 2: Cycle average 3: Moving average	R/W	
6	Input Ch 0 average value setting	Time average: 4 ~ 16000 [ms] Cycle average: 2 ~ 64000 [cycles] Moving average: 2 ~ 100 [samples]	R/W	
7	Input Ch 1 average value setting		R/W	
8	Channel output status setting	0: previous value 1: min. value 2: median 3: max.	R/W	
9	Set-up error information output area	10#: Input Ch range setting error 20#: Input Ch data type setting error 30#: Input Ch filter value setting error 40#: Input Ch averaging setting error 50#: Input Ch average value setting error 60#: Output Ch range setting error 70#: Output Ch data type setting error 80#: Ch output status setting error 90#: Output Ch input value range-over error (#: channel number)	R	GET

#### Note

- (1) If the memory address 0~8 area is entered with values different from the setting. U0x.01.8~U0x.01.B (setting error representative flag, for IEC type, %UX0.x.24 ~%UX0.x.27) is ON and runs with default values. The error information is displayed in the setting error information are (No. 9).
- (2) System areas (after No. 10) are read/write protected.  
Changing these areas may cause malfunction or failure of the product.

(1) Operating Channel Setting

The default setting for operating channel is 'Stop.'

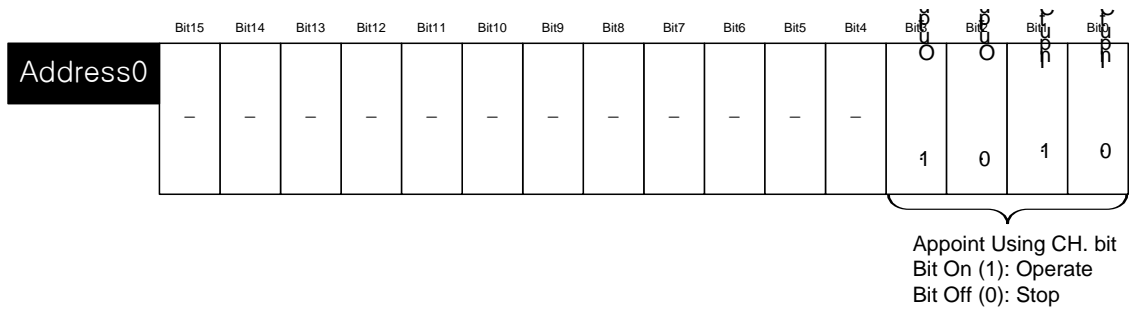

(2) I/O Range Setting

- (a) The analog I/O voltage range is DC 1~5V, DC 0~5V, DC 0~10V, and analog current I/O range is DC 4~20mA, DC 0~20mA.
- (b) Default range is DC 4~20mA.

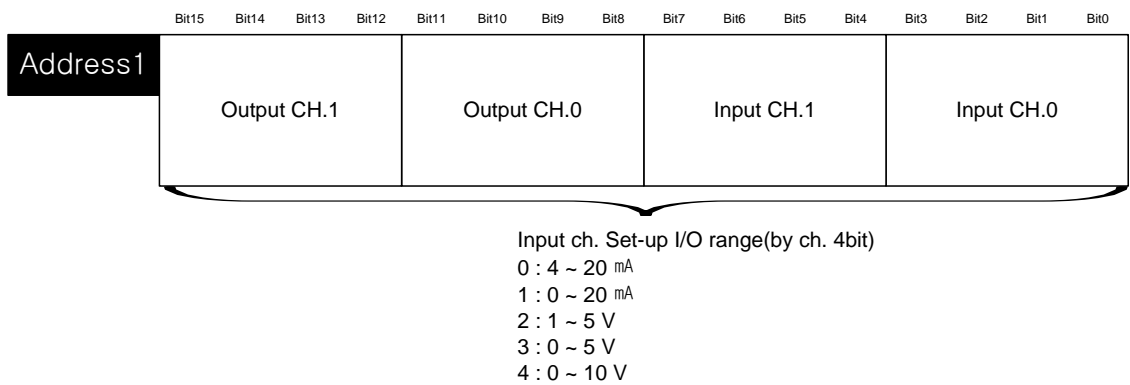

(3) I/O Data Type Setting

- (a) I/O data type can be set up for each channel.
- (b) If the I/O data type is not set up, all the channels are processed in 0~4000 range.

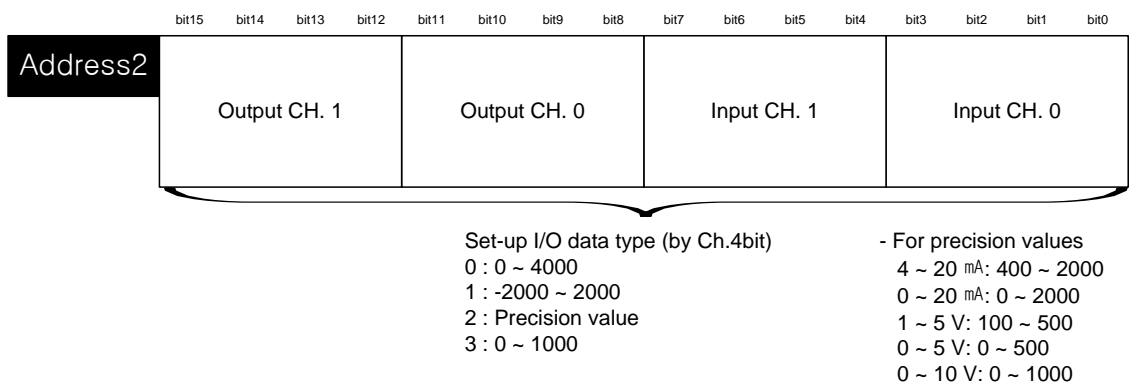

(4) Filter Constant Setting

- (a) If set to 0, no filtration is processed.
- (b) Default setting is 0 – no filtration process.



(5) Averaging Method Setting

- (a) Averaging method can be one of; time average, cycle average, moving average.
- (b) Default setting is no averaging throughout the channels.

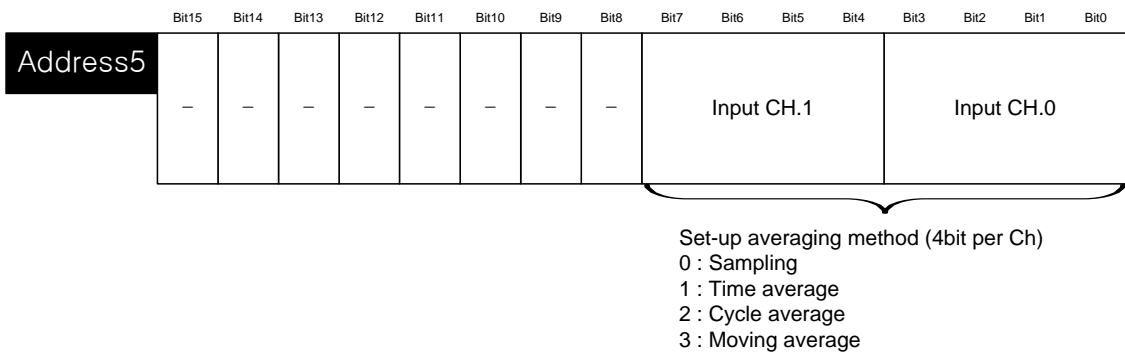

(6) Average Value Setting

- (a) Set up average values in accordance with the setting area of the averaging method.
- (b) If the average value is out of setting range, averaging is not applied.

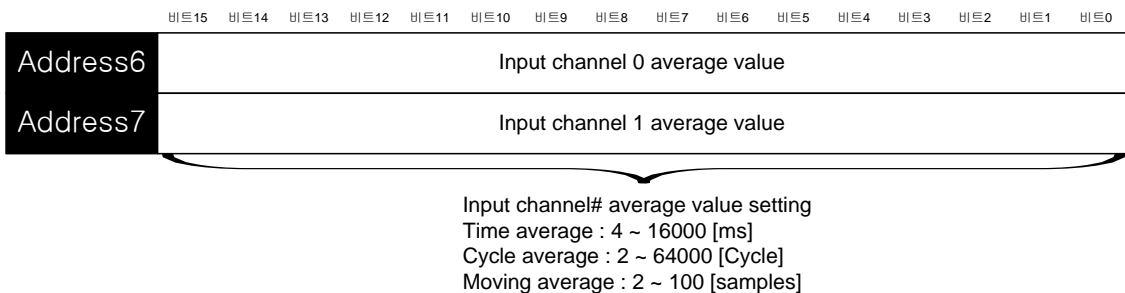

(7) Output Status Setting

- (a) This sets up the analog output status when the XGB base unit is changed from run to stop.
- (b) Default setting is the Previous Value output.

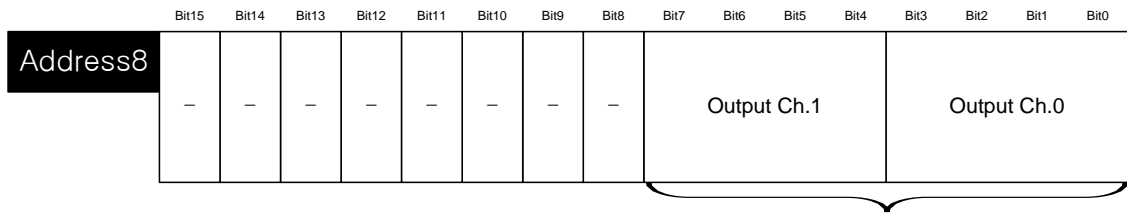

Output channel status setting (4 bit per Ch)  
 0 : Previous value output  
 1 : Min. value output  
 2 : Median value output  
 3 : Max. value output

(8) Error Code (Address 9)

- (a) Saves the error code detected by the analog I/O module.
- (b) The types and descriptions of the error are as follows.

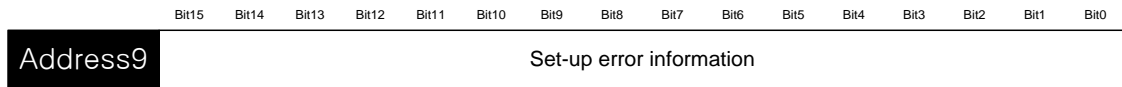

Type	Error Code	LED Lamp	Description	Priority Order	Remark
Input Error	10#	INPUT LED flickering 1s intervals	Input Ch range setting error	2	#: Ch No. Input Ch. 0,1 Output Ch. 0,1
	20#		Input Ch data type setting error	3	
	30#		Input Ch filter cons. Setting error	4	
	40#		Input Ch averaging setting error	5	
	50#		Input Ch average value setting error	6	
Output Error	60#	OUTPUT LED flickering 1s intervals	Output Ch range setting error	7	
	70#		Output Ch data type setting error	8	
	80#		Output Ch status setting error	9	
	90#		Output Ch input value range-over error	1	

- (c) In case of plural errors, the code with higher priority order will be saved.

(9) System Area (after Address 10)

- (a) System area (after address 10) is read/write protected.

	<b>Caution</b>	Modifying this area can cause malfunction of failure of product.
--	----------------	--

## 6.12 Example Program

- (1) This sample program sets up operating parameters of analog I/O module.
- (2) Initial settings are saved in the internal memory of the module by input by once.
- (3) The sample program below controls the I/O data of the analog I/O module at slot #1 and check open wire.

### 6.12.1 Example of [I/O Parameter] Usage

#### (1) I/O Parameter Setting Window

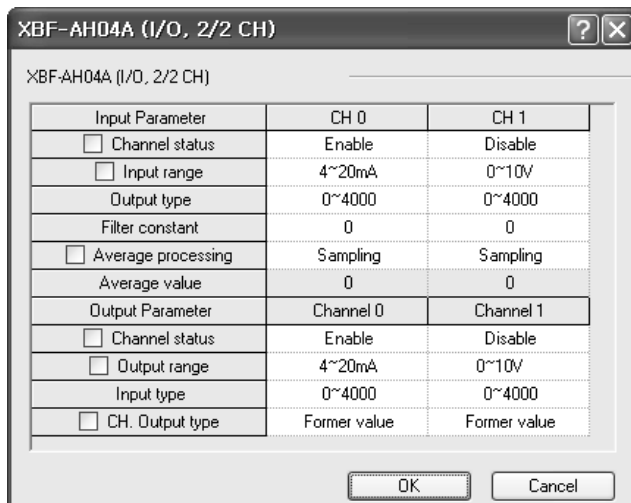
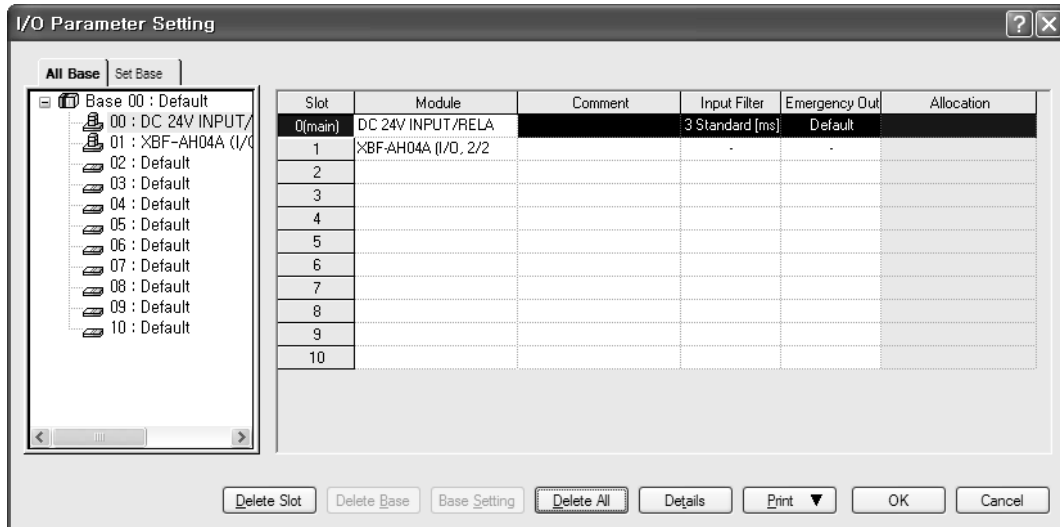

- (a) Input Channel 0 is set to operating channel and input range is set to 4~20mA.
- (b) Output Channel 0 is set to operating channel and output range is set to 4~20mA.

(2) Sample Input Program

Input CH0 program

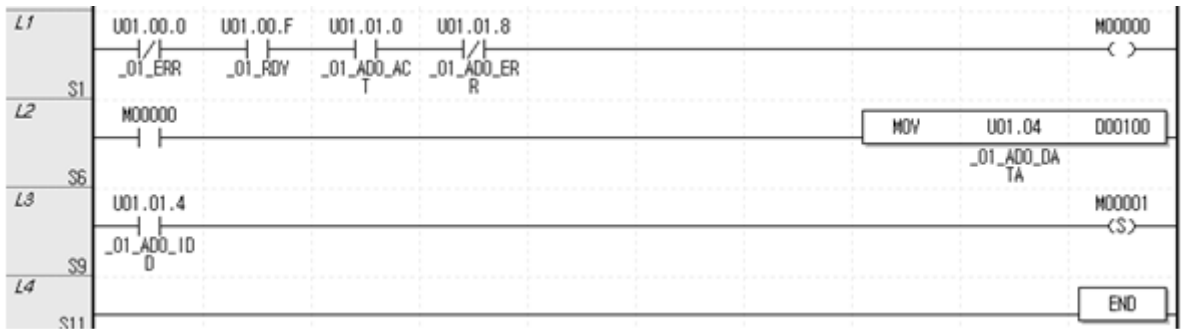

- (a) When the module is in normal operation, M0000 is turned On.  
 U01.00.0(Module Error) = Off  
 U01.00.F(Module Ready) = On  
 U01.01.0(Input Channel 0 in-operation) = On  
 U01.01.8(Input Channel 0 Error) = Off
- (b) When M0000 is ON, Input Channel 0 Converted Value(U01.04) is moved to D00100.
- (c) If open-wire error occurs in channel 0, U01.01.4(channel 0 open-wire) is ON, and M0001 bit is set.

(3) Sample Output Program

Output CH0 program

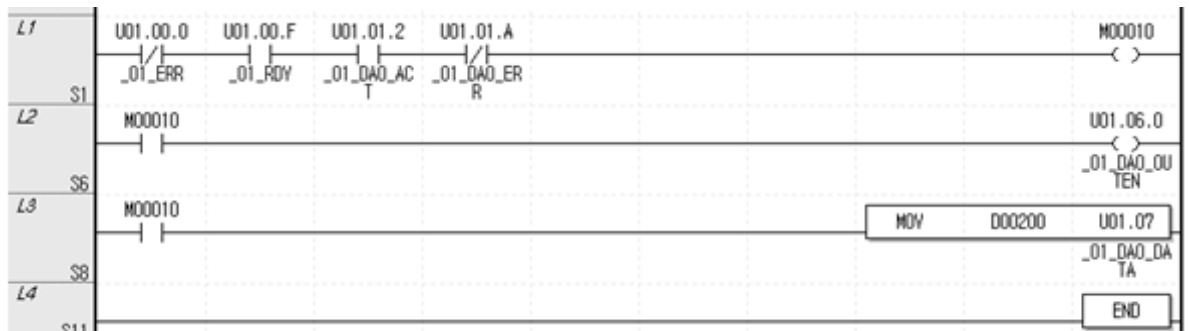

- (a) When the module is in normal operation, M00010 is turned ON.  
 U01.00.0(Module Error) = Off  
 U01.00.F(Module Ready) = On  
 U01.01.2(Output Channel 0 in-operation) = On  
 U01.01.A(Output Channel 0 Error) = Off
- (b) When M00010 is On, channel 0 output status setting (U01.06.0) is turned ON and output is permitted.
- (c) When M00010 is On, the data in D00200 is transmitted to Output Channel 0 input value (U01.07) and outputted.



(4) Sample Input Program (for IEC type)

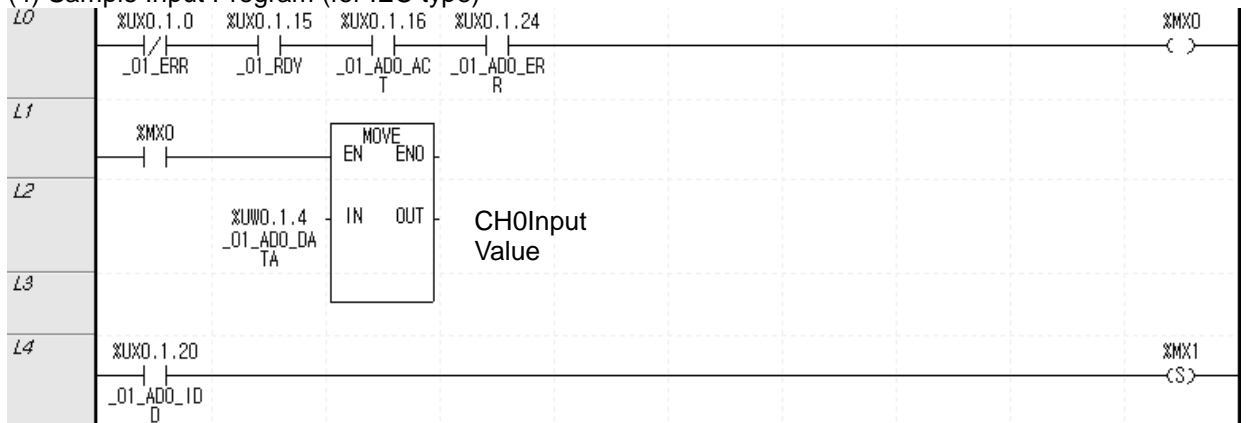

- (a) When the module is in normal operation, %MX0 is turned ON.  
 %UX0.1.0(Module Error) = Off  
 %UX0.1.15(Module Ready) = On  
 %UX0.1.16(Input Channel 0 in-operation) = On  
 %UX0.1.24(Input Channel 0 Error) = Off
- (b) When %MX0 is ON, Input Channel 0 Converted Value(%UW0.1.4) is transferred to “Channel 0 Input” variable.
- (c) If open-wire error occurs at Channel 0, %UX0.1.20(Channel0open) turns ON and %MX1 bit is set.

(5) Sample Output Program (for IEC type)

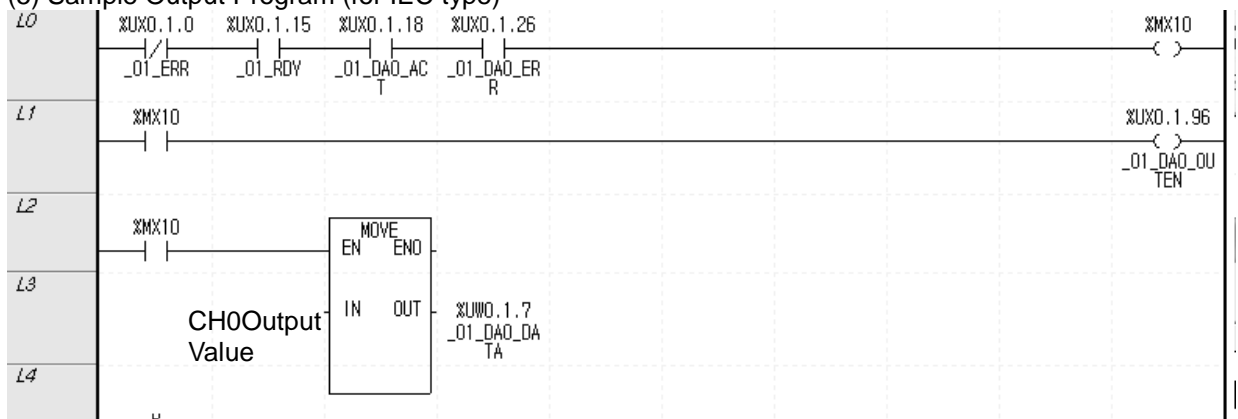

- (a) When the module is in normal operation, %MX10 is turned ON.  
 %UX0.1.0(Module Error) = Off  
 %UX0.1.15(Module Ready) = On  
 %UX0.1.18(Output Channel 0 in-operation) = On  
 %UX0.1.26(Output Channel 0 Error) = Off
- (b) When %MX10 is ON, Channel0 output status setting (%UX0.1.96) is turned ON and output is permitted
- (c) When %MX10 is ON, the data of the ‘Channel 0output’ variable is transferred to Output Channel 0 Input Value (%UW0.1.7) and outputted.

### 6.12.2 Exemplary Usage of PUT/GET Command

(1) Sample Input Program  
Input CH0 Program

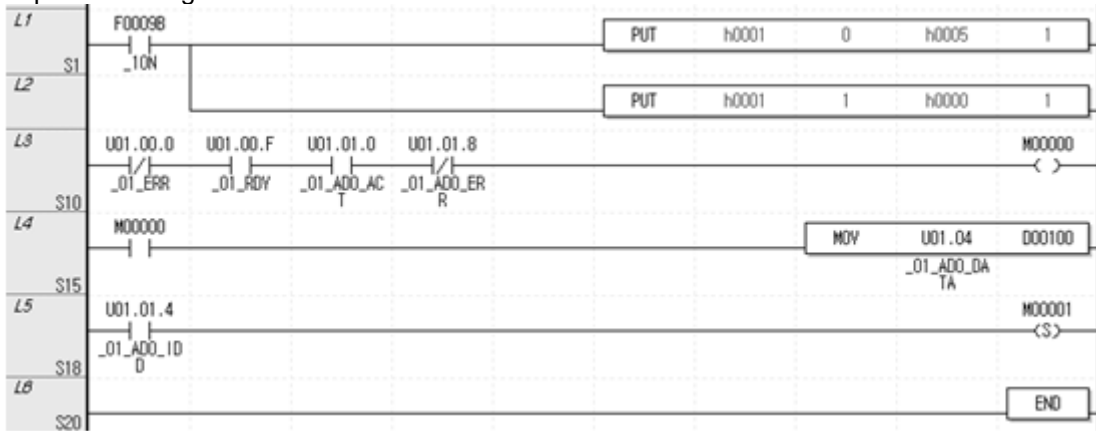

- (a) Using PUT command to write h0005 in the address 0, slot 1 to operate Input Channel 0 and Output Channel 0.
- (b) Using PUT command to write h0000 in the address 1, slot 1 to set the input range of Input Channel 0 to DC 4 ~ 20mA and the output range of the Output Channel 0 to DC 4 ~ 20mA.
- (c) When the module is in normal operation, M0000 is turned ON.  
 U01.00.0(Module Error) = Off,                    U01.00.F(Module Ready) = On  
 U01.01.0(Input Channel 0 in-operation) = ON,    U01.01.8(Input Channel 0 Error) = Off
- (d) When M0000 is ON, Input Channel 0 Converted Value(U01.04) is transferred to D00100.
- (e) If open-wire error occurs at Channel 0, U01.01.4(Channel0open) is ON, and M0001 bit is set.

(2) Sample Output Program  
Output CH0 Program

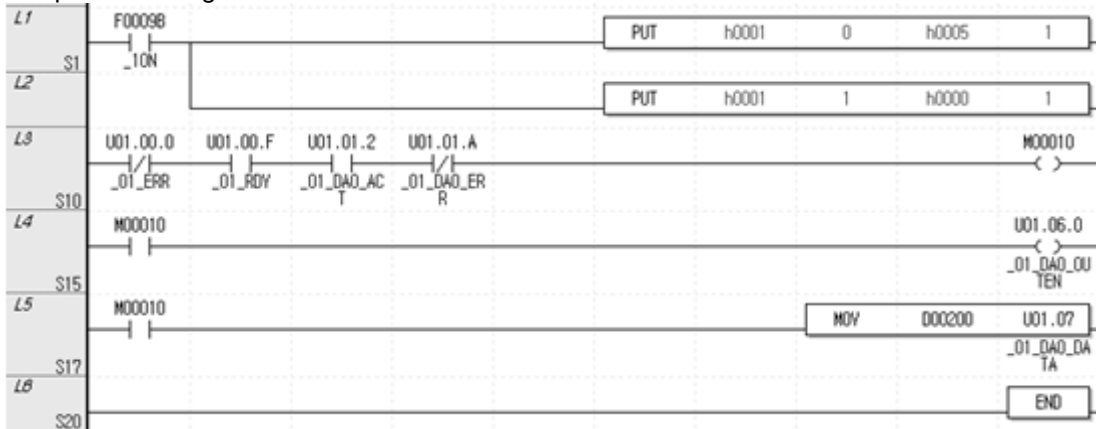

- (a) Using PUT command to write h0005 in the address 0, slot 1 to operate Input Channel 0 and Output Channel 0.
- (b) Using PUT command to write h0000 in the address 1, slot 1 to set the input range of Input Channel 0 to DC 4 ~ 20mA and the output range of the Output Channel 0 to DC 4 ~ 20mA.
- (c) When the module is in normal operation, M00010 is turned ON.  
 U01.00.0(Module Error) = Off,                    U01.00.F(Module Ready) = On  
 U01.01.2(Output Channel 0 in-operation) = ON,    U01.01.A(Output Channel 0 Error) = Off
- (d) When M00010 is ON, Channel 0 Output Status setting (U01.06.0) is turned ON and output is permitted.
- (e) When M00010 is ON, data of D00200 is transferred to Output Channel 0 Input Value (U01.07) and outputted.

## (3) Sample Input Program (for IEC type)

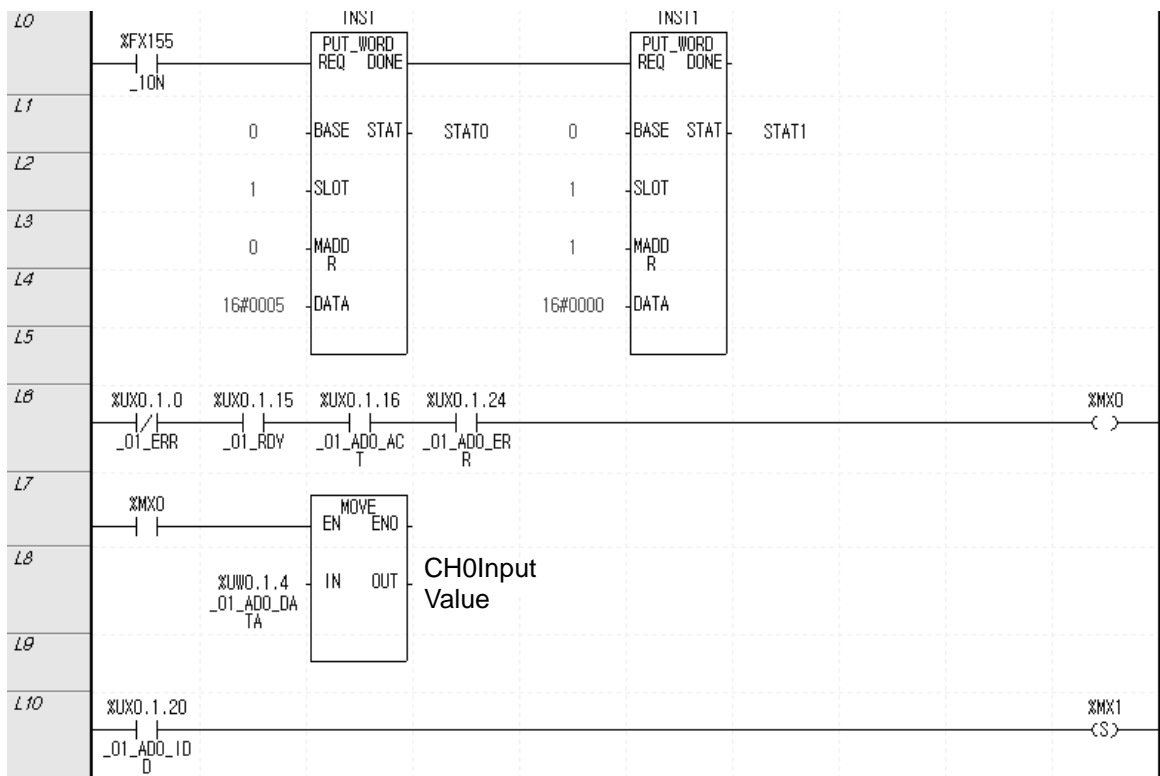

- Using PUT command to write h0005 in the address 0, slot 1 to operate Input Channel 0 and Output Channel 0.
- Using PUT command to write h0000 in the address 1, slot 1 to set the input range of Input Channel 0 to DC 4 ~ 20mA and the output range of the Output Channel 0 to DC 4 ~ 20mA.
- When the module is in normal operation, %MX0 is turned on.
  - %UX0.1.0(Module Error) = Off
  - %UX0.1.15(Module Ready) = On
  - %UX0.1.16(Input Channel 0 in-operation) = On
  - %UX0.1.24(Input Channel 0 Error) = Off
- When %MX0 is on, Input Channel 0 Converted Value (%UW0.1.4) is transferred to "Channel 0 Input" variable.
- If open-wire error occurs at Channel 0, %UX0.1.20(Channel0open) is turned on and %MX1 bit is set.

(4) Sample Output Program (for IEC type)

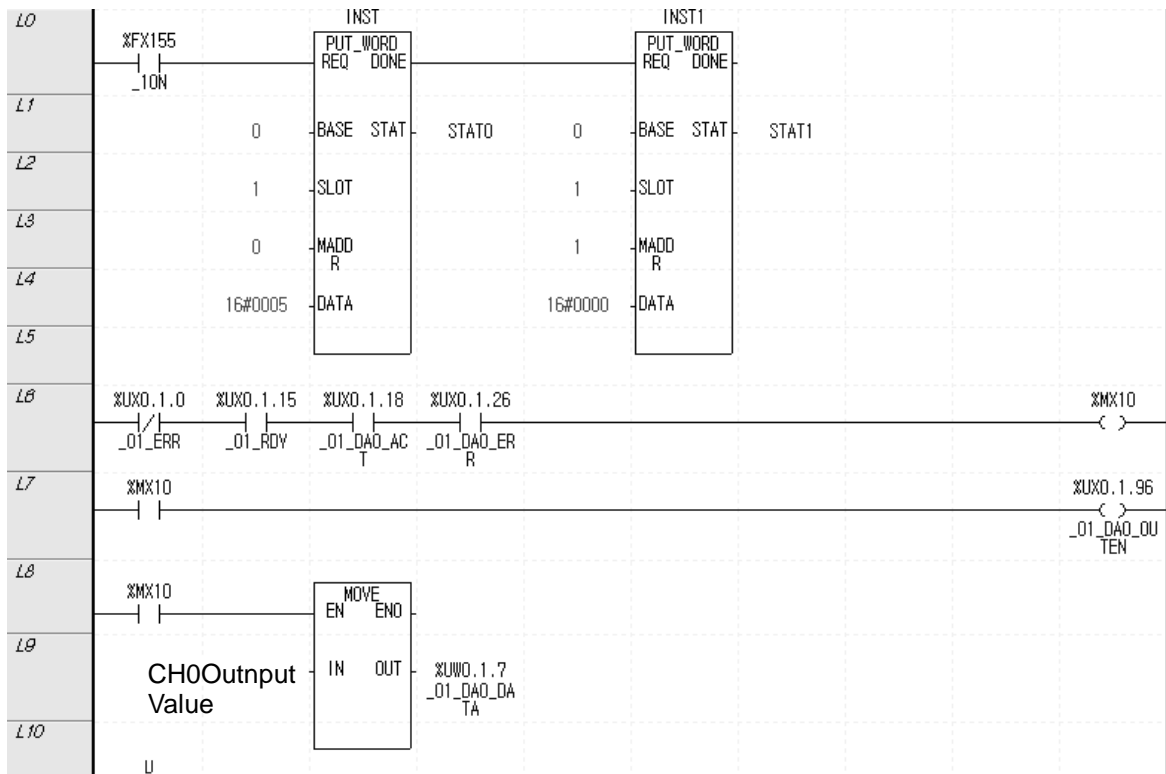

- (a) Using PUT command to write h0005 in the address 0, slot 1 to operate Input Channel 0 and Output Channel 0.
- (b) Using PUT command to write h0000 in the address 1, slot 1 to set the input range of Input Channel 0 to DC 4 ~ 20mA and the output range of the Output Channel 0 to DC 4 ~ 20mA.
- (c) When the module is in normal operation, %MX10 is turned on.  
 %UX0.1.0(Module Error) = Off  
 %UX0.1.15(Module Ready) = On  
 %UX0.1.18(Output Channel 0 in-operation) = On  
 %UX0.1.26(Output Channel 0 Error) = Off
- (d) When %MX10 is on, Channel 0 Output Status setting (%UX0.1.96) is turned on and output is permitted.
- (e) When %MX10 is on, data of the 'Channel 0output' variable is transferred to Output Channel 0 Input Value (%UW0.1.7) and outputted.

## 6.13 Troubleshooting

This section describes methods for identifying the troubles which may occur during the operation of analog I/O module, and their solutions.

### 6.13.1 LED Indication for Error

An analog I/O module has INPUT LED and OUTPUT LED to indicate error status of the module.

Classification	Normal State	Channel Open (Input)	Parameter Setting Error	Module H/W Failure (Serious Failure)
INPUT LED	On	Flickering 1s intervals	Flickering 1s intervals (input parameter setting error)	Flickering 0.2s intervals
OUTPUT LED	On	N/A	Flickering at 1s intervals (output parameter setting error)	Flickering 0.2s intervals
Module Behavior	All functions are normal	All functions are performed. Indicates min. input value	All functions work at default parameter setting	Module cannot function
Action	-	Check input wire	Check parameter setting	Request for A/S

### 6.13.2 Checking Module Condition

XG5000's system monitor enables verification of the analog I/O module conditions (module type, module information, OS version).

#### (1) Procedure

The verification can be done in 2 ways;

- (a) [Monitor] -> [System Monitor] -> mouse right click on module icon -> [Module Information]
- (b) [Monitor] -> [System Monitor] -> double click module icon.

#### (2) Module Information

- (a) Module type: shows the information on the present module.
- (b) Module information: shows the OS version of the module.
- (c) OS version: shows release date of Module OS.

### 6.13.3 Troubleshooting

(1) INPUT LED or OUTPUT LED is off.

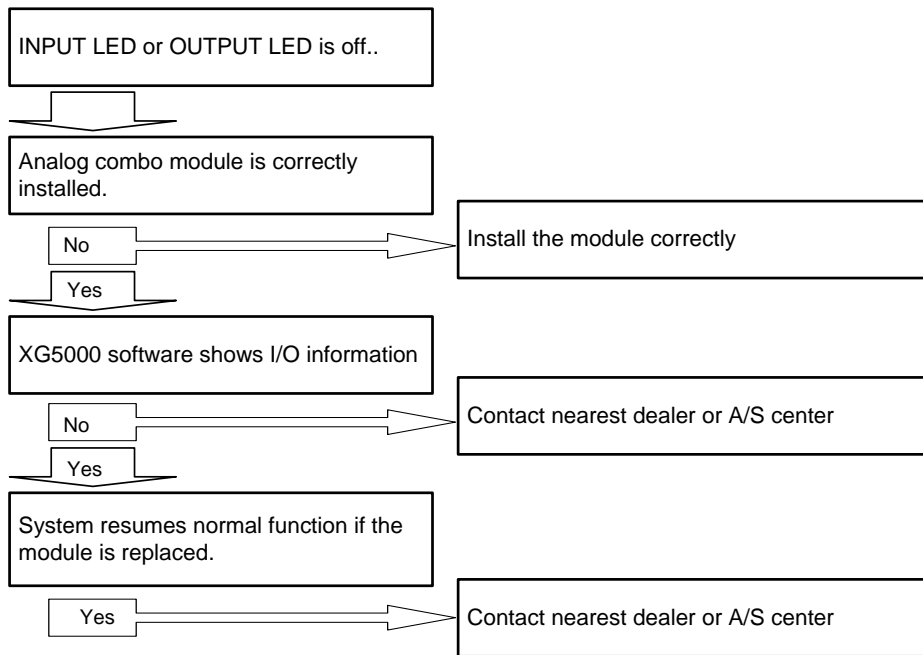

(2) INPUT LED flickering.

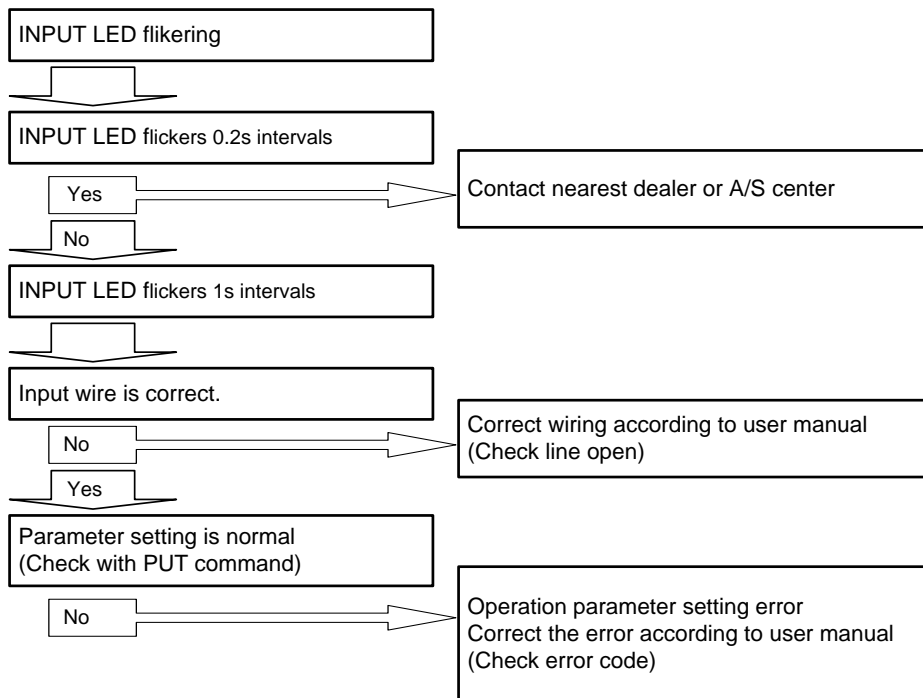

(3) OUTPUT LED flickering

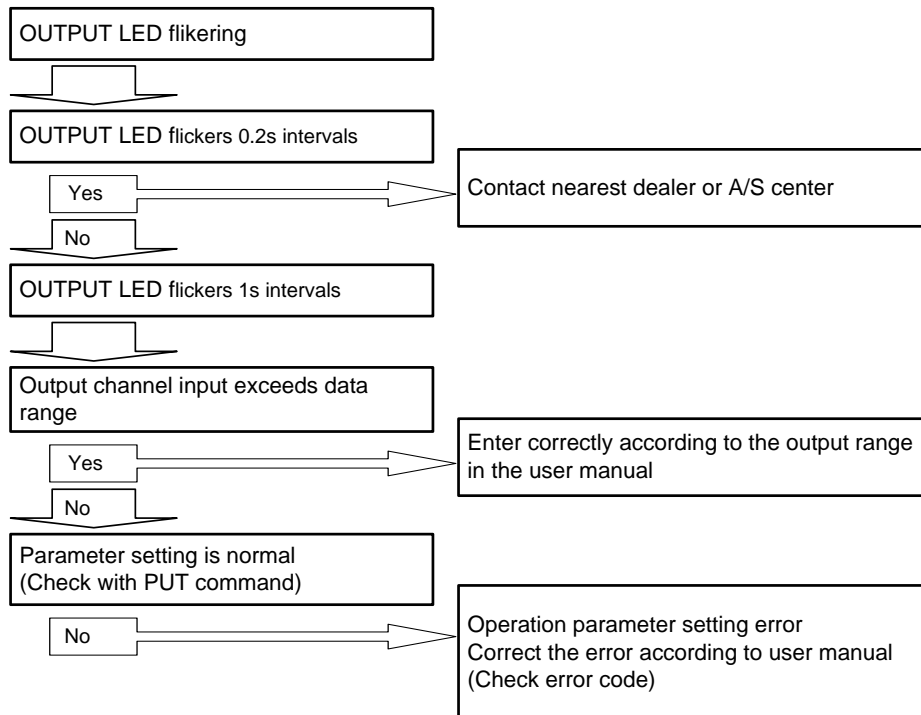

(4) Analog I/O value is abnormal.

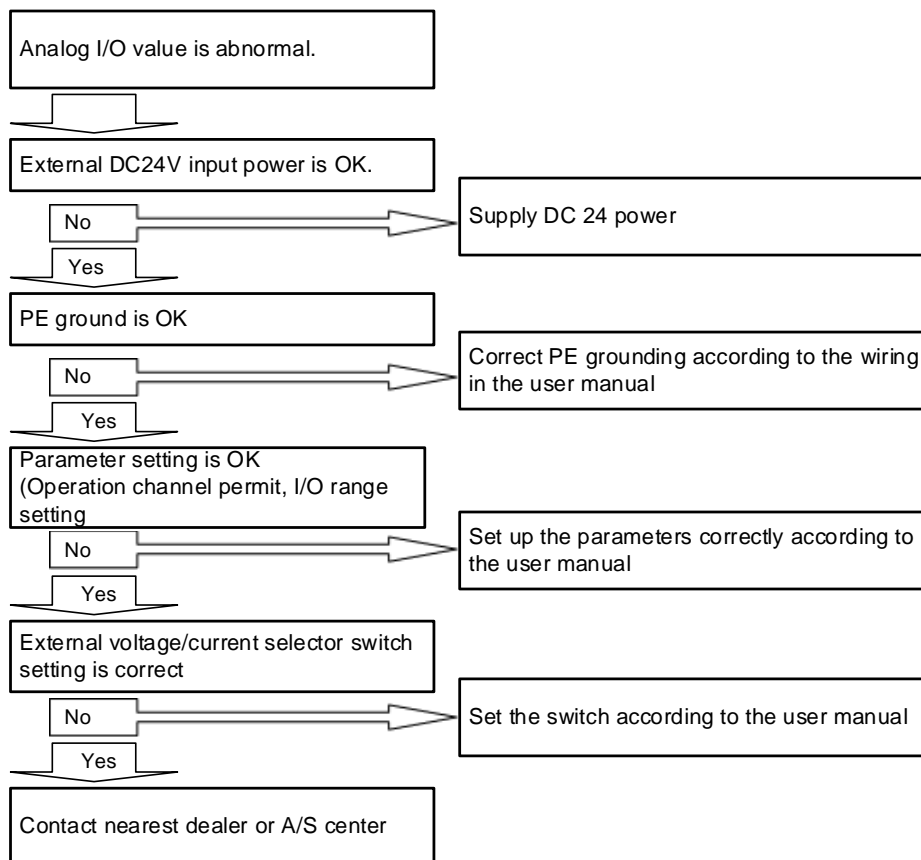

(3) OUTPUT LED flickering

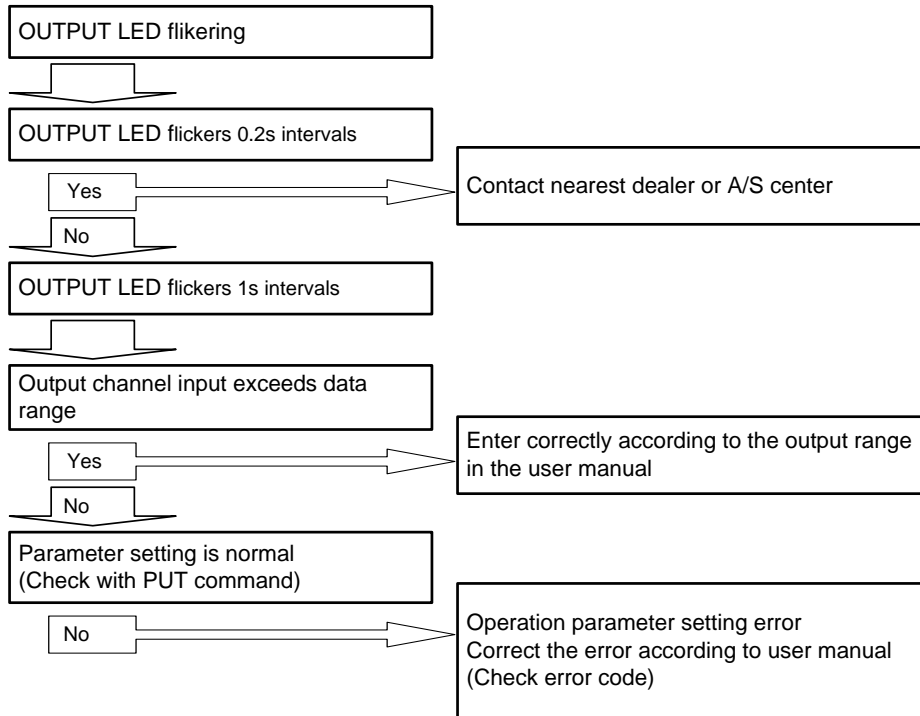

(4) Analog I/O value is abnormal.

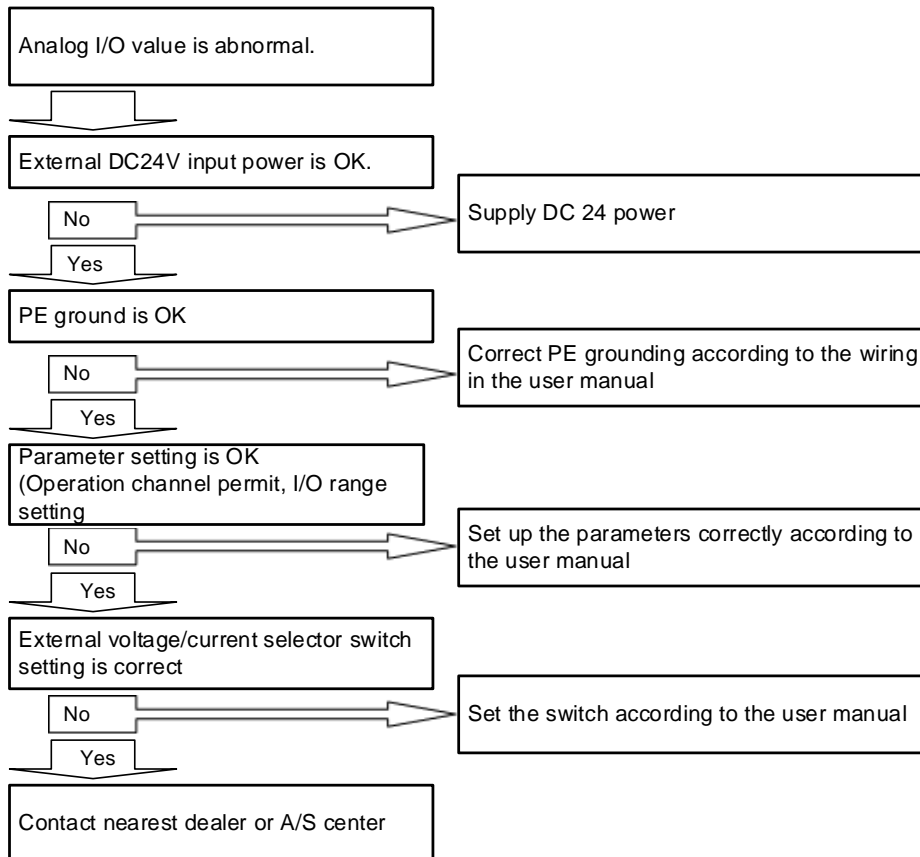



# Chapter 7 Analog Input Module (XBF-AD08A)

## 7.1 Setting Sequence before operation

Before using the analog input module, follow steps below.

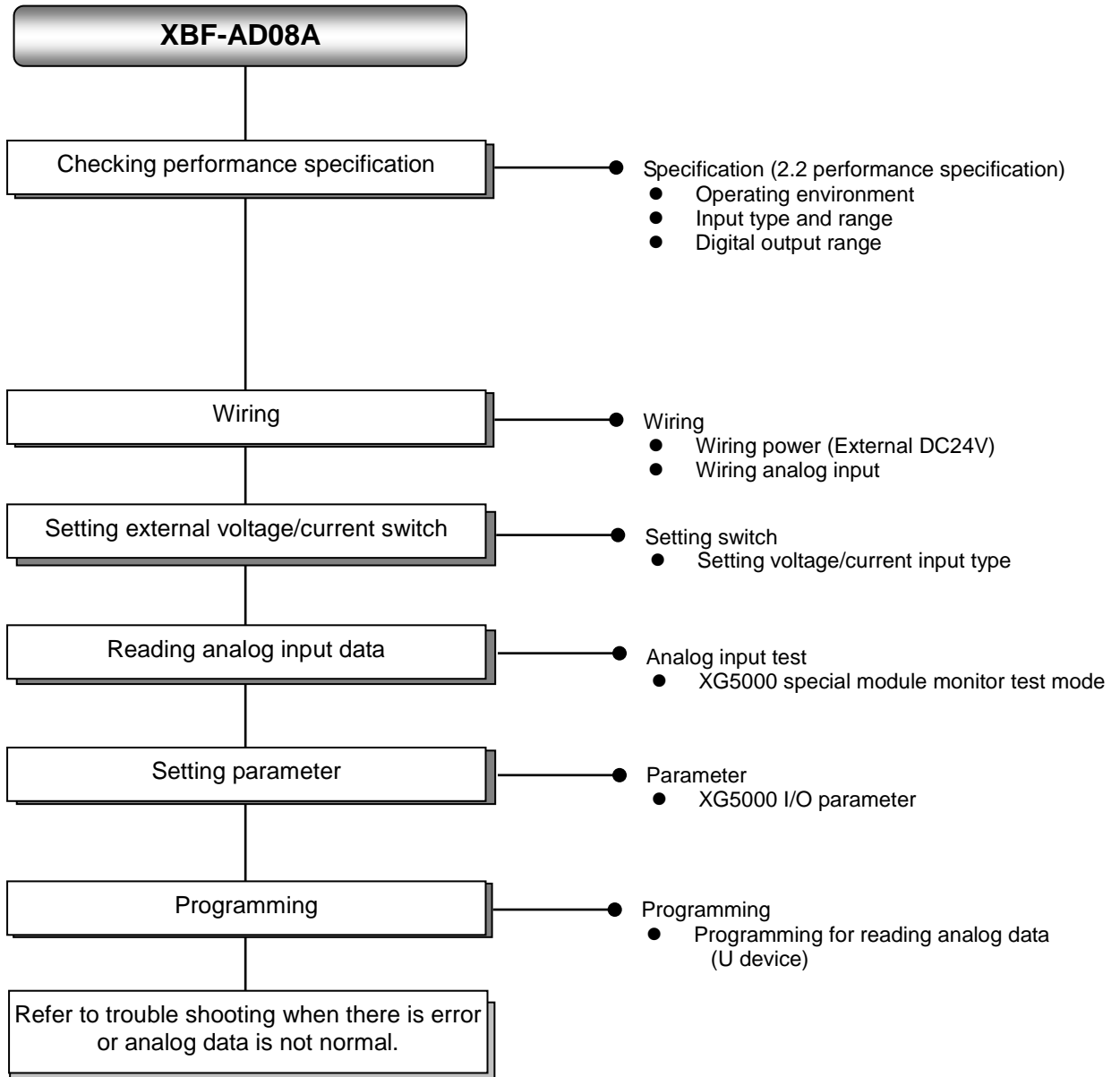

## 7.2 Specifications

### 7.2.1 General specifications

General specifications are as follows.

No.	Item	Specifications	Related specifications			
1	Ambient temperature	0°C ~ +55°C	-			
2	Storage temperature	-25°C ~ +70°C	-			
3	Ambient humidity	5 ~ 95%RH (Non-condensing)	-			
4	Storage humidity	5 ~ 95%RH (Non-condensing)	-			
5	Vibration resistance	Occasional vibration		-	IEC61131-2	
		Frequency	Acceleration	Amplitude		How many times
		5 ≤ f < 8.4 Hz	-	3.5 mm		10 times each directions (X, Y and Z)
		8.4 ≤ f ≤ 150 Hz	9.8 m/s <sup>2</sup> (1G)	-		
		For continuous vibration				
		Frequency	Acceleration	Amplitude		
		5 ≤ f < 8.4 Hz	-	1.75 mm		
8.4 ≤ f ≤ 150 Hz	4.9 m/s <sup>2</sup> (0.5G)	-				
6	Shock resistance	<ul style="list-style-type: none"> <li>Peak acceleration: 147 m/s<sup>2</sup>(15G)</li> <li>Duration: 11ms</li> <li>Half-sine, 3 times each direction per each axis</li> </ul>	IEC61131-2			
7	Noise resistance	Square wave Impulse noise	AC: ± 1,500V DC: ± 900V	LS ELECTRIC standard		
		Electrostatic discharge	Voltage : 4kV (contact discharging)	IEC 61131-2, IEC 61000-4-2		
		Radiated electromagnetic field noise	80 ~ 1,000 MHz, 10V/m	IEC 61131-2, IEC 61000-4-3		
		Fast transient /bust noise	Segment Voltage	Power supply module 2kV	Digital/analog input/output communication interface 1kV	IEC 61131-2, IEC 61000-4-4
8	Environment	Free from corrosive gasses and excessive dust	-			
9	Altitude	Up to 2,000 ms	-			
10	Pollution degree	Less than equal to 2	-			
11	Cooling	Air-cooling	-			

7.2.2 Performance specifications

Performance specifications are as follows.

Items		Performance specification	
Number of channel		8 channels	
Analog input range	Type	Voltage	Current
	Range	DC 1 ~ 5V DC 0 ~ 5V DC 0 ~ 10V (Input resistance: 1 MΩ or above)	DC 4 ~ 20mA DC 0 ~ 20mA (Input resistance 250 Ω)
Digital output	Type	12 bit binary data	
	Range	Signed value	0 ~ 4000
		Unsigned value	-2000 ~ 2000
		Precise value	100 ~ 500 (DC 1 ~ 5V) 0 ~ 500 (DC 0 ~ 5V) 0 ~ 1000 (DC 0 ~ 10V)
Percentile value		0 ~ 1000	
Max. resolution		1/4000	
		1.25mV (DC 1~5V, 0~5V) 2.5mV (DC 0~10V)	5μA (DC4~20mA, 0~20mA)
Accuracy		±0.5% or less	
Max. conversion speed		1.5ms/channel	
Absolute max. output		DC ±15V	DC ±25mA
Additional function	Filter function	Digital filter (4 ~ 64,000ms)	
	Average function	Time average (4 ~ 16,000ms)	
		Count average (2 ~ 64,000 times)	
		Moving average (2 ~ 100)	
Alarm function	Detecting disconnection (DC 1~5V, DC4~20mA)		
Insulation method		Photo-coupler insulation between I/O terminal and PLC power (No insulation between channels)	
Input terminal		11 point terminal block	
I/O points occupied		Fixed type: 64 points	
Max. no. of installation		7 [When using XBM-Dxxx□ (□: "S", "H", "H2", "HP") type] 7 (when using XB(E)C-DxxxSU type) 10 (when using XB(E)C-DxxxH type or XB(E)C-DxxxU type) Not Available (when using XB(E)C-DxxxE type)	
Consumption current	Inner (DC 5V)	105mA	
	External (DC 24V)	85mA	
Weight		81g	
Module supply power source		20.4~28.8 V	

Note1) In order to use analog input module (XBF-AD08A), the following version is needed.

Main unit	Version information
XBM-DxxxS type	V2.6
XBC-DxxxH type	V1.9
XEC-DxxxH type	V1.3
XBC-DxxxS type	V1.0

### 7.3 Name of part and function

Respective designations of the parts are as described below.

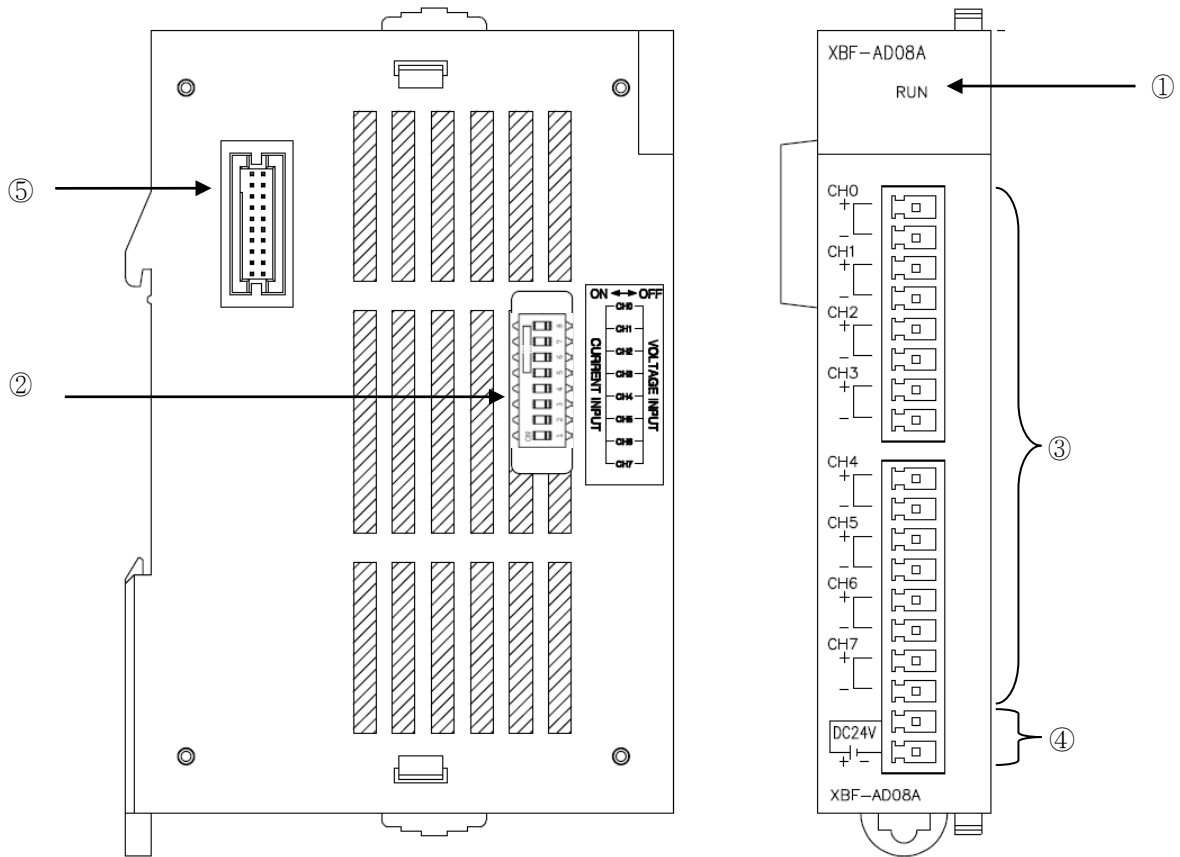

No.	Name	Description
①	LED	<ul style="list-style-type: none"> <li>▶ Displays the operation status of XBF-AD08A</li> <li>On: Operation normal</li> <li>Flickering: Error occurs (1s intervals)</li> <li>Off: power off or module error</li> </ul>
②	Voltage/current selector switch	<ul style="list-style-type: none"> <li>▶ switch to select voltage/current input of analog input CH0~CH7</li> </ul>
③	Terminal block	<ul style="list-style-type: none"> <li>▶ Wiring terminal block to connect with external device (Analog input)</li> </ul>
④	External power supply terminal	<ul style="list-style-type: none"> <li>▶ Terminal for DC24V external power supply</li> </ul>
⑤	Connector for expansion	<ul style="list-style-type: none"> <li>▶ Connection connector for expansion module</li> </ul>

## 7.4 Characteristic of I/O conversion

The input/output ranges of voltage and current can be set up per channel with user program or I/O parameters. The I/O types of digital data are defined as follows.

- (1) Unsigned Value
- (2) Signed Value
- (3) Precise Value
- (4) Percentile Value

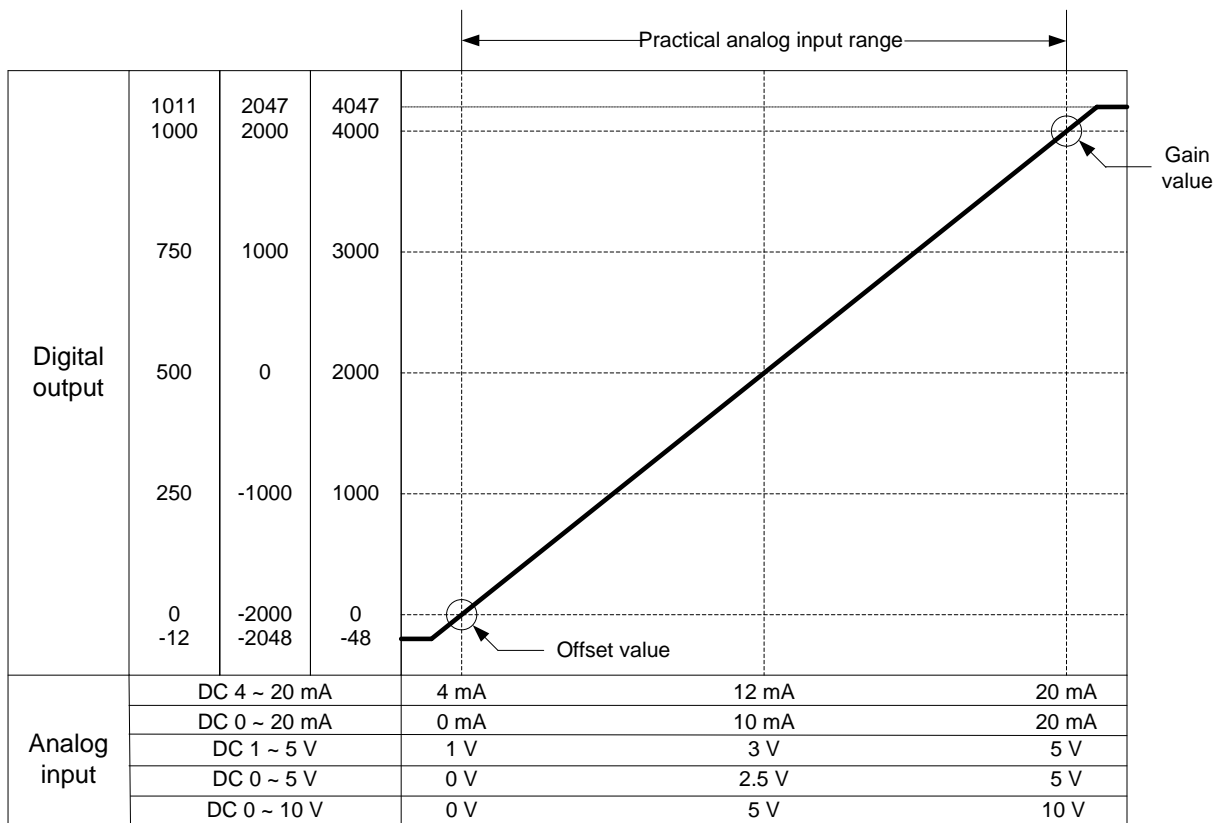

### (1) DC 4 ~ 20mA Range Input

Digital Output Range	Analog Input Current (mA)						
	3.81	4	8	12	16	20	20.18
Unsigned Value (0 ~ 4000)	-48	0	1000	2000	3000	4000	4047
Signed Value (-2000 ~ 2000)	-2048	-2000	-1000	0	1000	2000	2047
Precise Value (400 ~ 2000)	381	400	800	1200	1600	2000	2018
Percentile Value(0 ~ 1000)	-12	0	250	500	750	1000	1011

## (2) DC 0 ~ 20mA Range Input

Digital Output Range	Analog Input Current (mA)						
	-0.24	0	5	10	15	20	20.23
Unsigned Value (0 ~ 4000)	-48	0	1000	2000	3000	4000	4047
Signed Value (-2000 ~ 2000)	-2048	-2000	-1000	0	1000	2000	2047
Precise Value (0 ~ 2000)	-24	0	500	1000	1500	2000	2023
Percentile Value(0 ~ 1000)	-12	0	250	500	750	1000	1011

## (3) DC 1 ~ 5V Range Input

Digital Output Range	Analog Input Voltage (V)						
	0.96	1	2	3	4	5	5.04
Unsigned Value (0 ~ 4000)	-48	0	1000	2000	3000	4000	4047
Signed Value (-2000 ~ 2000)	-2048	-2000	-1000	0	1000	2000	2047
Precise Value (100 ~ 500)	96	100	200	300	400	500	504
Percentile Value(0 ~ 1000)	-12	0	250	500	750	1000	1011

## (4) DC 0 ~ 5V Range Input

Digital Output Range	Analog Input Voltage (V)						
	-0.06	0	1.25	2.5	3.75	5	5.05
Unsigned Value (0 ~ 4000)	-48	0	1000	2000	3000	4000	4047
Signed Value (-2000 ~ 2000)	-2048	-2000	-1000	0	1000	2000	2047
Precise Value (0 ~ 500)	-6	0	125	250	375	500	505
Percentile Value(0 ~ 1000)	-12	0	250	500	750	1000	1011

## (5) DC 0 ~ 10V Range Input

Digital Output Range	Analog Input Voltage (V)						
	-0.12	0	2.5	5	7.5	10	10.11
Unsigned Value (0 ~ 4000)	-48	0	1000	2000	3000	4000	4047
Signed Value (-2000 ~ 2000)	-2048	-2000	-1000	0	1000	2000	2047
Precise Value (0 ~ 1000)	-12	0	250	500	750	1000	1011
Percentile Value(0 ~ 1000)	-12	0	250	500	750	1000	1011

## 7.5 Accuracy

Accuracy of digital output value does not change even if input range is changed. Figure below shows the range of the accuracy with analog input range of 0 ~ 10 V and digital output type of unsigned value selected.

Accuracy of XBF-AD08A is  $\pm 0.5\%$ .

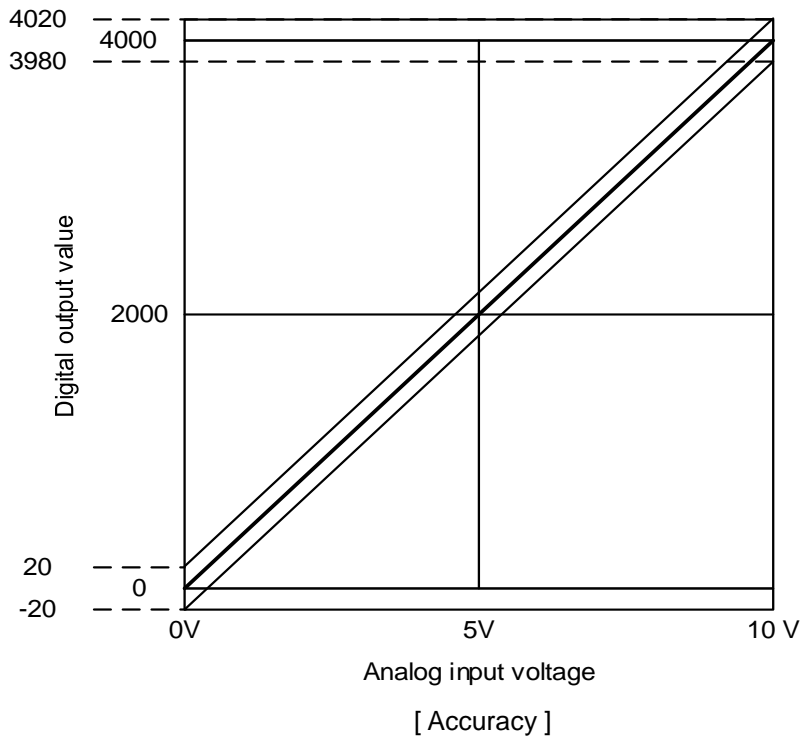

(1) Accuracy when using 5V input

$$4000 \times 0.5\% = 20$$

Therefore the range of the accuracy will become  $(2000-20) \sim (2000+20) = 1980 \sim 2020$  when using 5V input.

(2) Accuracy when using 10V input

$$4000 \times 0.5\% = 20$$

Therefore the range of the accuracy will become  $(4000-20) \sim (4000+20) = 3980 \sim 4020$  when using 10V input.

## 7.6 Functions of Analog Input Module

The functions of XBF-AD08A Module are as follows.

Function	Description
Channel operation/stop setting	<ul style="list-style-type: none"> <li>Specify operation/stop of the channel which will perform A/D and D/A conversion.</li> <li>Specifying unused channels as Stop can shorten overall operation time.</li> </ul>
I/O Voltage /current range setting	<ul style="list-style-type: none"> <li>Specify desired range of analog I/O.</li> <li>Select voltage/current with external switch, and set up range with parameter.</li> <li>Analog Mix Module provides 2 ranges(4~20mA, 0~20mA) of current I/O and 3 ranges (1~5V, 0~5V, 0~10V) of voltage I/O.</li> </ul>
I/O data type setting	<ul style="list-style-type: none"> <li>Specify digital I/O types.</li> <li>This module provides 4 output data types (Unsigned, Signed, Precision, and Percentile Values)</li> </ul>
A/D input conversion method	<ul style="list-style-type: none"> <li>Sampling Process               <ul style="list-style-type: none"> <li>If A/D conversion method has not been specified, the module processes sampling.</li> </ul> </li> <li>Filter process               <ul style="list-style-type: none"> <li>Filters rapid changes in input value by external noise.</li> </ul> </li> <li>Averaging process               <ul style="list-style-type: none"> <li>Outputs A/D converted value averaged by time, cycle, and moving.</li> </ul> </li> </ul>
D/A output status setting	<ul style="list-style-type: none"> <li>Sets up channel output state at transition from run to stop.</li> <li>Provides 4 output selections (Previous, Minimum, Mean, Maximum Values)</li> </ul>

### 7.6.1 Sampling Process

In popular A/D conversion process, analog input signals are collected at constant time intervals and A/D converted. The time elapsed for the analog signals converted into digital signals and saved in memory device depends upon the number of channels used.

$$(\text{Process Time}) = (\text{No. of Channels Used}) \times (\text{Conversion Rate})$$

(Ex.) Process time when using 3 of 4 I/O channels;

$$3 \times 1 \text{ ms} = 3.0 \text{ ms}$$

The term 'sampling' means taking analog signal values at certain time intervals.



### 7.6.2 Filtering Function

The input value of the designated channel is calculated with previously filtered input value using preset filter constant (time constant 63.2%) by the formula below;

$$PresentlyFilteredInput = \frac{(PreviouslyFilteredInput \times FilterConstant) + (PresentInput \times 1ms \times No.ofChannelsUsed)}{FilterConstant + (1ms \times No.ofChannelsUsed)}$$

Filter Constant setting range = 4 ~ 64000 [ms]

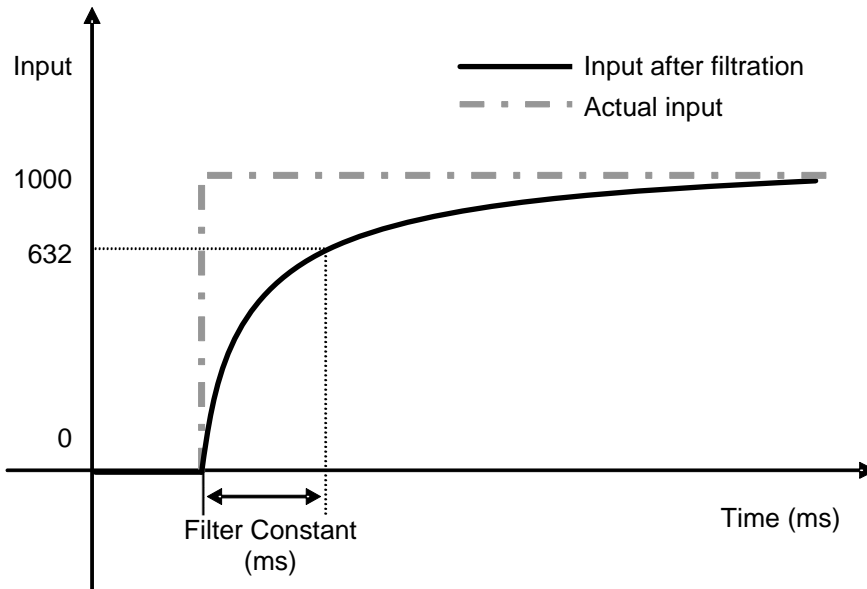

In the above graph, if the input value changes rapidly from 0 to 100, the input value is filtered. Filter (time) constant is the time required for input values to vary by 63.2% of the actual input value.

### 7.6.3 Averaging Function

(1) Average by Time

The input values of the designated channel are accumulated for the preset time, and the average value of the total sum is outputted in digital data.

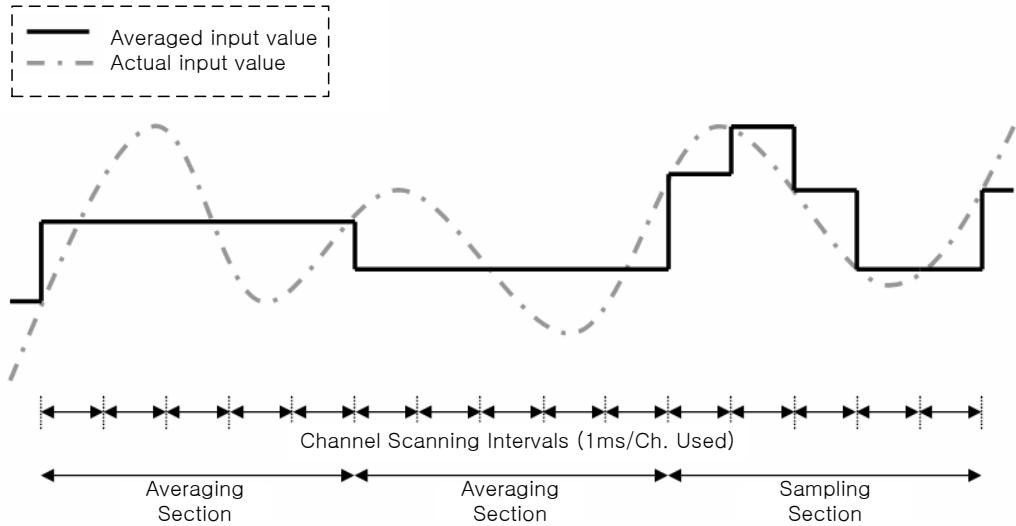

Setting Range = 4 ~ 16000 [ms]

For time averaging, No. of averaging cycles are calculated with the No. of channels used as below;

$$\text{No. Averaging Cycles} = \frac{\text{AverageTime}}{\text{No.ofChannelsUsed} \times 1\text{ms}}$$

(2) Average by Cycles

The input values of the designated channel are accumulated for the preset cycles, and the average value of the total sum is outputted in digital data.

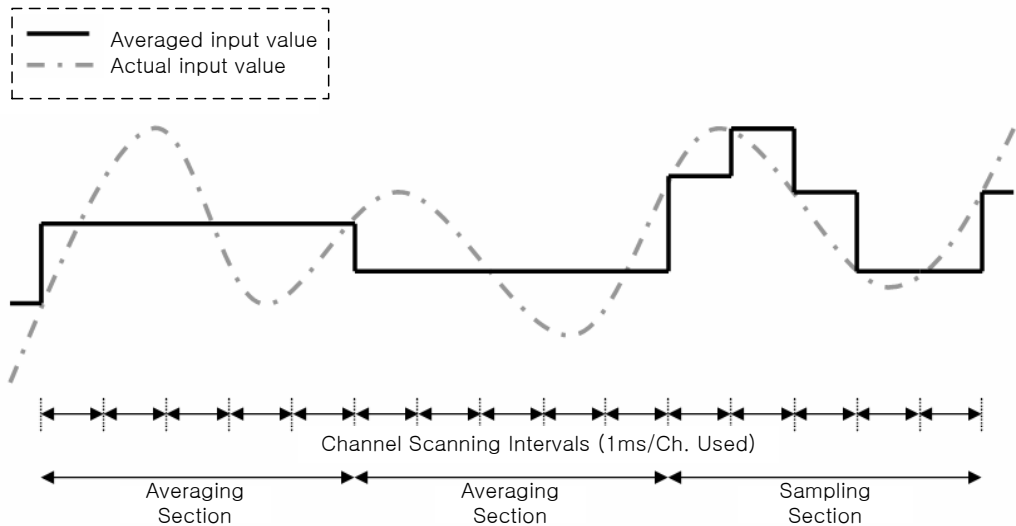

Setting Range = 2 ~ 64000 [Cycle]

For cycle averaging, averaging interval is calculated with the No. of channels used.

$$\text{AveragingInterval [ms]} = \text{AveragingCycle} \times \text{No.ofChannelsUsed} \times 1\text{ms}$$

(3) Moving Average

The inputs into the designated channel are accumulated for the preser number, and its average is calculated and outputted in digital data. However, in moving average method, each scan provides its average value.

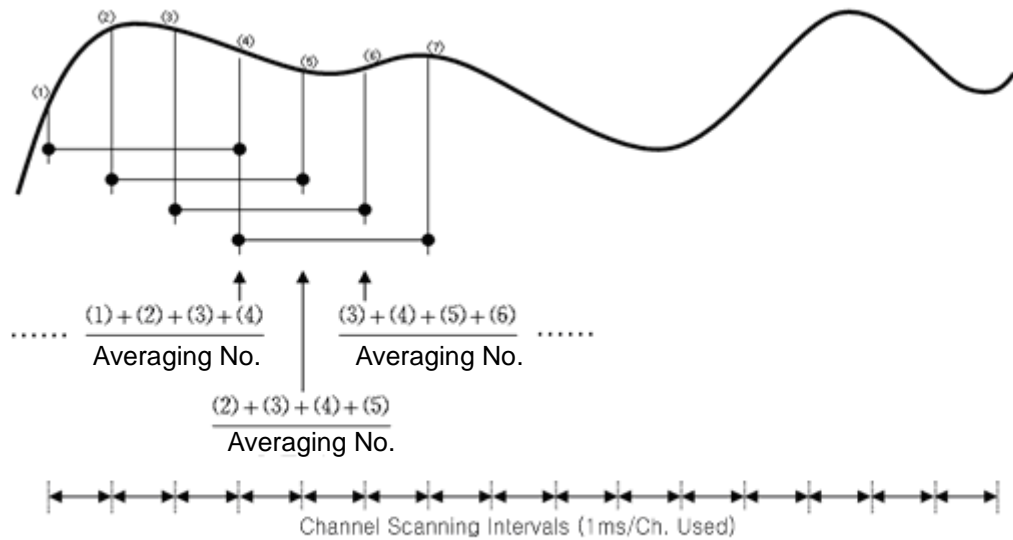

**Note**

- (1) In case of time/cycle averages. The input value is not outputted at every conversion, but the previous value is maintained until the average time or cycle is reached.
- (2) In case of moving averages, the converted input is averaged with the previously entered value and the result is outputted at every conversion. Therefore, data response is faster than time/cycle averaging methods.
- (3) The three averaging methods can be processed simultaneously with the filter function described earlier. In such case, the filter function is executed first, and averaging function is processed to output the average value in digital data, which is expressed with the finally-processed value.

### 7.6.4 Disconnection detecting Function

The analog mix module has a diagnostic function which can detect and indicate open input line, when voltage input range of DC 1~5V or current input range of DC 4~20mA is selected as its analog input range. If the module indicates open input line, check the wiring.

- (1) If the wiring to the module is open, the Input LED flickering 1 second intervals and the respective error code is generated.
- (2) Line open detection is available for each channel. However, open indication is provided only for the channel selected for the operation. The Input LED is common for the input channels 0 and 1, and flickering if 1 or more channels are open.

Input Connection	Channel Operation	Input LED State	Open Line Flag
Normal	Working	On	Off
	Stopped	On	Off
Input wire open or disconnected	Working	Flickering (1s intervals)	On
	Stopped	On	Off

- (3) At line open, the line open flag of the channel turns on, and turns Off at correction.

Open Flag	Description
U0x.10.0	Ch 0 open
U0x.10.1	Ch 1 open
U0x.10.2	Ch 2 open
U0x.10.3	Ch 3 open
U0x.10.4	Ch 4 open
U0x.10.5	Ch 5 open
U0x.10.6	Ch 6 open
U0x.10.7	Ch 7 open

- (4) At line open, the least of all input values is indicated.

## 7.7 Wiring

### 7.7.1 Precaution for wiring

- (1) Don't let AC power line near to A/D conversion module's external input sign line. With an enough distance kept away between, it will be free from surge or inductive noise.
- (2) Cable shall be selected in due consideration of ambient temperature and allowable current, whose size is not less than the max. cable standard of AWG22 (0.3mm<sup>2</sup>).
- (3) Don't let the cable too close to hot device and material or in direct contact with oil for long, which will cause damage or abnormal operation due to short-circuit.
- (4) Check the polarity when wiring the terminal.
- (5) Wiring with high-voltage line or power line may produce inductive hindrance causing abnormal operation or defect.

### 7.7.2 Wiring examples

- (1) Input resistance of current input circuit is 250 Ω (typ.).
- (2) Input resistance of voltage input circuit is 1 MΩ (min.).
- (3) Enable the necessary channel only.
- (4) Analog input module doesn't support power for input device. Use the external power supplier.
- (5) Wiring example of analog input

In case of voltage/current input, wiring is same. Adjust the voltage/current setting switch according to the case.

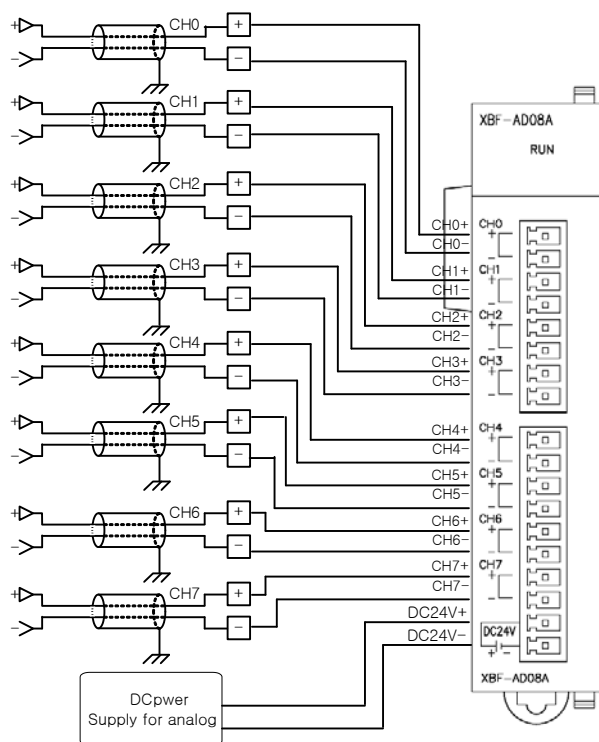

(6) Wiring example of analog input 2-Wire sensor/transmitter

- In case of voltage/current input, wiring is same. Adjust the voltage/current setting switch according to the case.

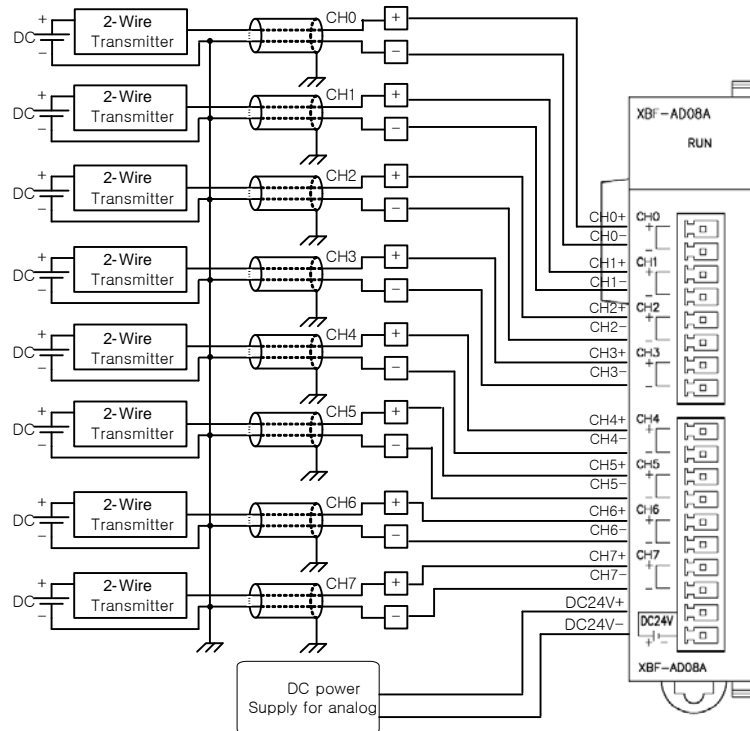

(7) Wiring example of analog input 4-Wire sensor/transmitter

- In case of voltage/current input, wiring is same. Adjust the voltage/current setting switch according to the case.

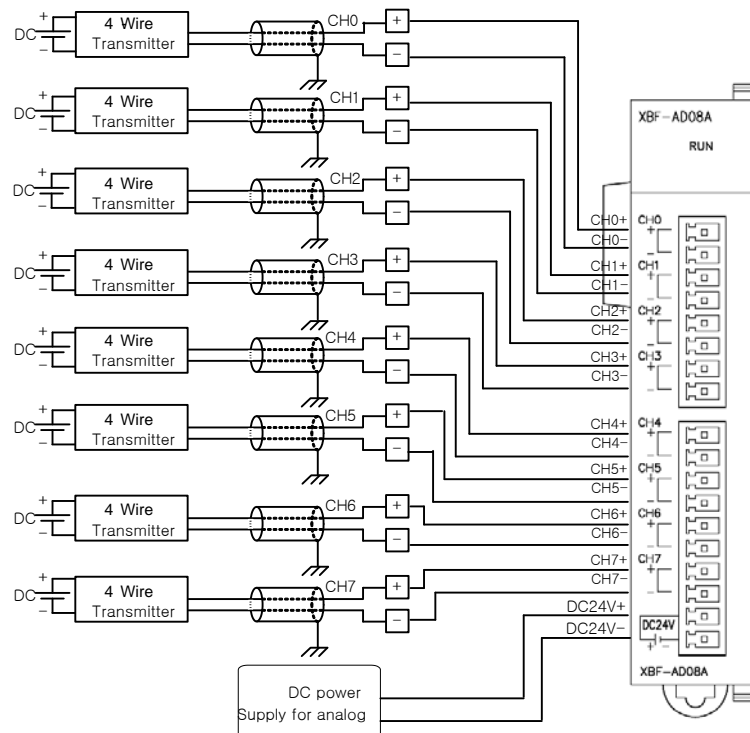

- (8) Relationship between voltage input accuracy and wiring length  
 In voltage input, the wiring (cable) length between transmitter or sensor and module has an effect on digital-converted values of the module as specified below;

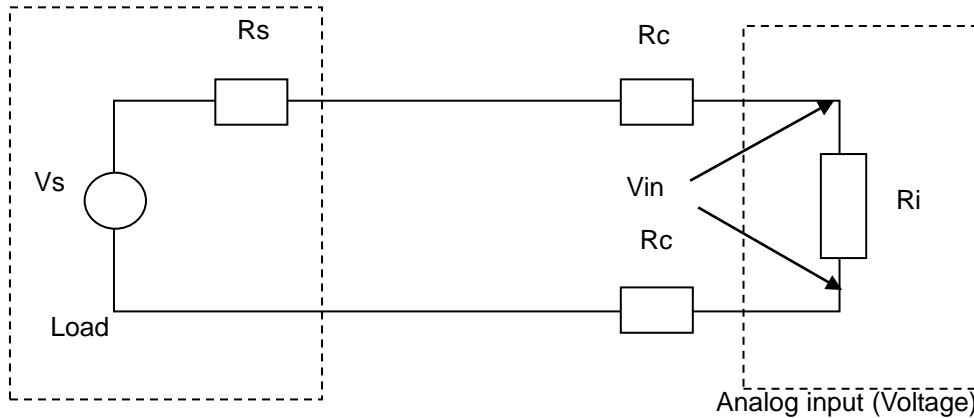

Where,

$R_c$ : Resistance value due to line resistance of cable

$R_s$ : Internal resistance value of transmitter or sensor

$R_i$ : Internal resistance value ( $1M\Omega$ ) of voltage input module

$V_{in}$ : Voltage allowed to analog input module

%  $V_i$ : Tolerance of converted value (%) due to source and cable length in voltage input

$$V_{in} = \frac{R_i \times V_s}{[R_s + (2 \times R_c) + R_i]}$$

$$\% V_i = \left(1 - \frac{V_{in}}{V_s}\right) \times 100 \%$$

## 7.8 Operation Parameter Setting

A/D conversion module's operation parameters can be specified through XG5000's [I/O parameters].

### (1) Settings

For the user's convenience of A/D conversion module, XG5000 provides GUI (Graphical User Interface) for parameters setting of A/D conversion module. Setting items available through [I/O parameters] on the XG5000 project window are as described below in the table.

Item	Details
[I/O parameter]	(a) Specify the following setting items necessary for the module operation. <ol style="list-style-type: none"> <li>1) Channel Enable/Disable setting</li> <li>2) Setting ranges of input voltage/current</li> <li>3) Output data format setting</li> <li>4) Filter constant setting</li> <li>5) Average processing method setting</li> <li>6) Average value setting</li> </ol> (b) If downloading is complete Parameter set by user in XG5000 is saved in Flash memory of XGB main unit.

### (2) Usage of [I/O Parameter]

- (a) Create a project with XG5000. See XG5000 Program Manual for project creation.
- (b) In the Project window, double-click [I/O Parameter].

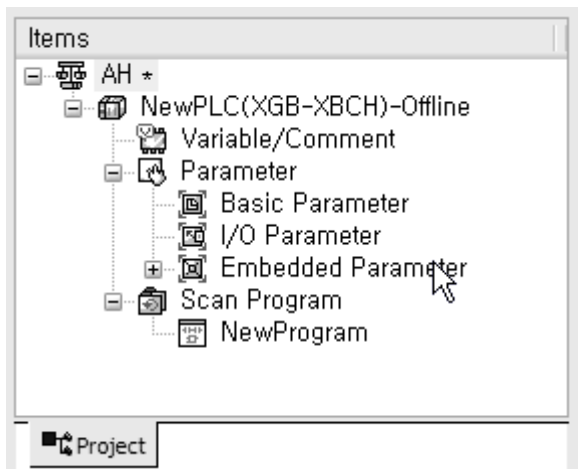



(c) In the [I/O Parameter Setting] window, find out the slot of the base where the analog mix module is installed, and click it.

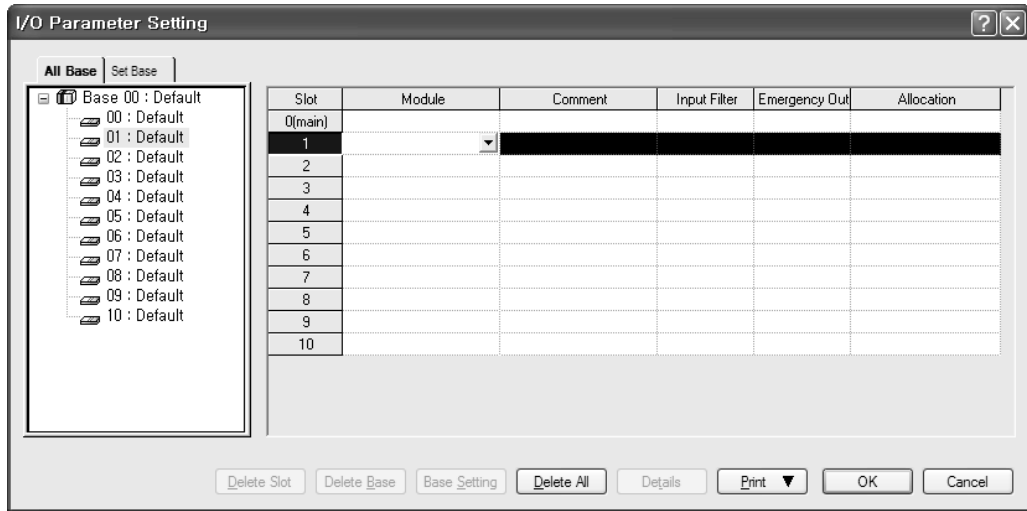

(d) In the above window, click the arrow button to call the window where the module can be selected. Find out the module and select it.

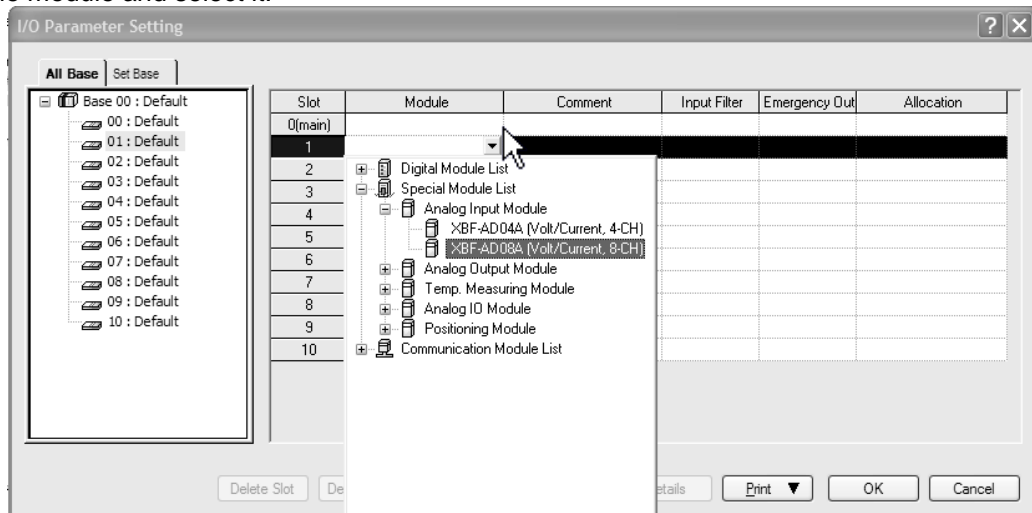

(e) To set up parameter, double click with the respective slot being selected, or click [Detail] button.

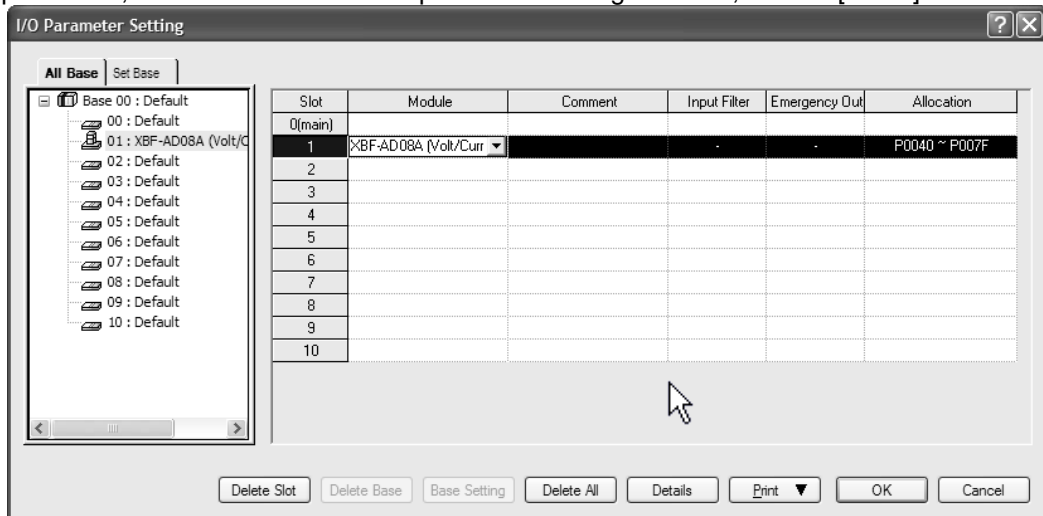

(f) The window below where parameters can be set up by channel appears. Click the item to set up. The parameters which can be set up appear by item.

XBF-AD08A (Volt/Current, 8-CH) ? X

XBF-AD08A (Volt/Current, 8-CH)

Parameter	CH 0	CH 1	CH 2	CH 3	CH 4	CH 5	CH 6	CH 7
<input type="checkbox"/> Channel status	Disable <span style="font-size: small;">▼</span>	Disable	Disable	Disable	Disable	Disable	Disable	Disable
<input type="checkbox"/> Input range	4~20mA	4~20mA	4~20mA	4~20mA	4~20mA	4~20mA	4~20mA	4~20mA
Output type	0~4000	0~4000	0~4000	0~4000	0~4000	0~4000	0~4000	0~4000
Filter constant	0	0	0	0	0	0	0	0
<input type="checkbox"/> Average processing	Sampling	Sampling	Sampling	Sampling	Sampling	Sampling	Sampling	Sampling
Average value	0	0	0	0	0	0	0	0

## 7.9 Special Module Monitoring Functions

The functions of the special module monitor are as follows.

(1) Start-up of [Special Module Monitor]

Select [Online] -> [Connect], and [Monitor] -> [Special Module Monitor] to start up. [Special Module Monitor] menu is enabled only in the [Online] condition.

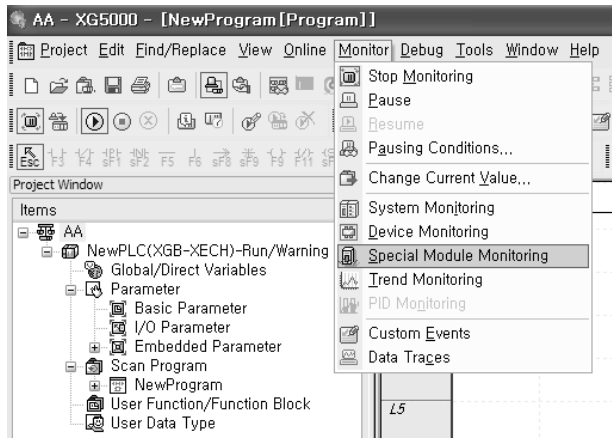

**Notes**

- 1) The screen may not function properly if the system resources are not sufficient. In this case, close the screen, exit other applications, and rerun XG5000.
- 2) The I/O parameters set up in [Special Module Monitor] condition are temporarily set up for testing purpose. Therefore, these I/O parameters are deleted after exit from [Special Module Monitor].
- 3) the test function of the [Special Module Monitor] enables testing analog mix modules without sequence programming.

(2) Usage of [Special Module Monitor]

(a) With the XG5000 in connection (online) with the base unit of PLC, select [Monitor] -> [Special Module Monitor]. The Select Special Module window shown below will appear showing the type of the special modules and base/slot information. In the list dialog, the modules present in the PLC system are displayed.

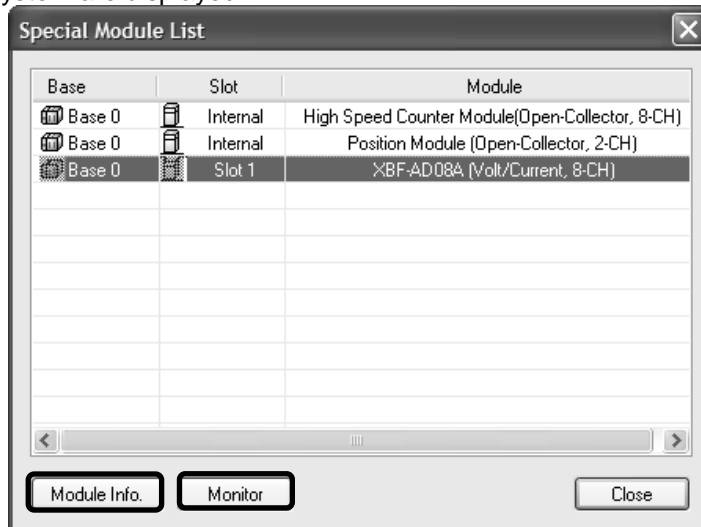

- (b) In the above window, select the special module and click [Module Info.] to see the information window below.

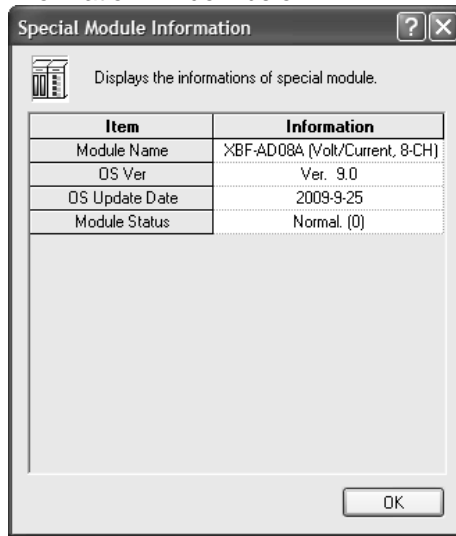

- (c) Click the [Monitor] button in the “Special Module” window. The “Special Module Monitor” window will appear as shown below.

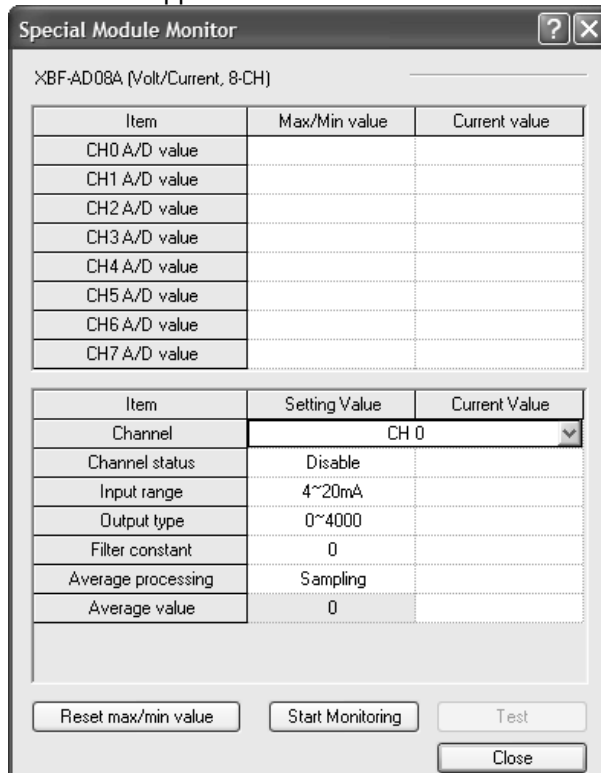

- (d) [Start Monitoring]: click [Start Monitoring] to look up the digital input data of the channel currently in operation. The screen shot below is a monitoring window when all the channels are in operation status.

The screenshot shows the 'Special Module Monitor' window for 'XBF-AD08A (Volt/Current, 8-CH)'. It contains two tables. The first table shows monitoring data for all 8 channels, with all current values at 0. The second table shows detailed settings for 'CH 0', including channel status (Disable), input range (4~20mA), output type (0~4000), filter constant (0), average processing (Sampling), and average value (0). Callout boxes point to the monitoring data table and the CH0 detail table.

Item	Max/Min value	Current value
CH0 A/D value	0 / 0	0
CH1 A/D value	0 / 0	0
CH2 A/D value	0 / 0	0
CH3 A/D value	0 / 0	0
CH4 A/D value	0 / 0	0
CH5 A/D value	0 / 0	0
CH6 A/D value	0 / 0	0
CH7 A/D value	0 / 0	0

Item	Setting Value	Current Value
Channel	CH 0	
Channel status	Disable	Disable
Input range	4~20mA	4~20mA
Output type	0~4000	0~4000
Filter constant	0	0
Average processing	Sampling	Sampling
Average value	0	0

The screen executing [Start Monitoring]

- (e) [Test]: this function is used to change the current parameter settings of the analog mix module. Click the settings in the fields in the bottom screen to change the parameters. [Test] can be set up only when the operation status of the XGB base unit is STOP.

The screenshot shows the 'Special Module Monitor' window for 'XBF-AD08A (Volt/Current, 8-CH)'. The monitoring data table is identical to the previous screenshot. The detailed settings table for 'CH 0' has been updated: 'Channel status' is now 'Enable', 'Input range' is '4~20mA', and 'Output type' is '0~4000'. The 'Test' button is highlighted.

Item	Max/Min value	Current value
CH0 A/D value	0 / 0	0
CH1 A/D value	0 / 0	0
CH2 A/D value	0 / 0	0
CH3 A/D value	0 / 0	0
CH4 A/D value	0 / 0	0
CH5 A/D value	0 / 0	0
CH6 A/D value	0 / 0	0
CH7 A/D value	0 / 0	0

Item	Setting Value	Current Value
Channel	CH 0	
Channel status	Enable	Enable
Input range	4~20mA	4~20mA
Output type	0~4000	0~4000
Filter constant	0	0
Average processing	Sampling	Sampling
Average value	0	0

The screen executing [Test]

(f) Minimum/Maximum Value Monitoring

The minimum and maximum values of the input channels in operation can be monitored. However, the Max/Min values in the window are based on the current value. Therefore, the Max/Min values are not saved when exiting from the [Monitoring/Testing Screen].

The screenshot shows the 'Special Module Monitor' window for the XBF-AD08A module. It contains two tables and several control buttons. The first table lists 8 channels (CH0-CH7) with their respective Max/Min and Current values. The second table shows settings for Channel 0. A callout box labeled 'Resets Max/Min value' points to the 'Reset max/min value' button at the bottom left of the window.

Item	Max/Min value	Current value
CH0 A/D value	0 / 0	0
CH1 A/D value	0 / 0	0
CH2 A/D value	0 / 0	0
CH3 A/D value	0 / 0	0
CH4 A/D value	0 / 0	0
CH5 A/D value	0 / 0	0
CH6 A/D value	0 / 0	0
CH7 A/D value	0 / 0	0

Item	Setting Value	Current Value
Channel	CH 0	
Channel status	Disable	Disable
Input range	4~20mA	4~20mA
Output type	0~4000	0~4000
Filter constant	0	0
Average processing	Sampling	Sampling
Average value	0	0

Buttons: Reset max/min value, Stop Monitoring, Test, Close.

The screen executing [Max/Min Value Monitoring]

(g) Close

[Close] button is for ending/closing the monitoring/testing screen. Maximum, minimum, and current values are not saved at exit.

## 7.10 Register U devices

The variables for each module are automatically registered by referring to the information of the special modules set up in the [I/O Parameter]. User can modify variables and descriptions.

(1) Registration Procedure

(a) In [I/O Parameter], set up special module in slot.

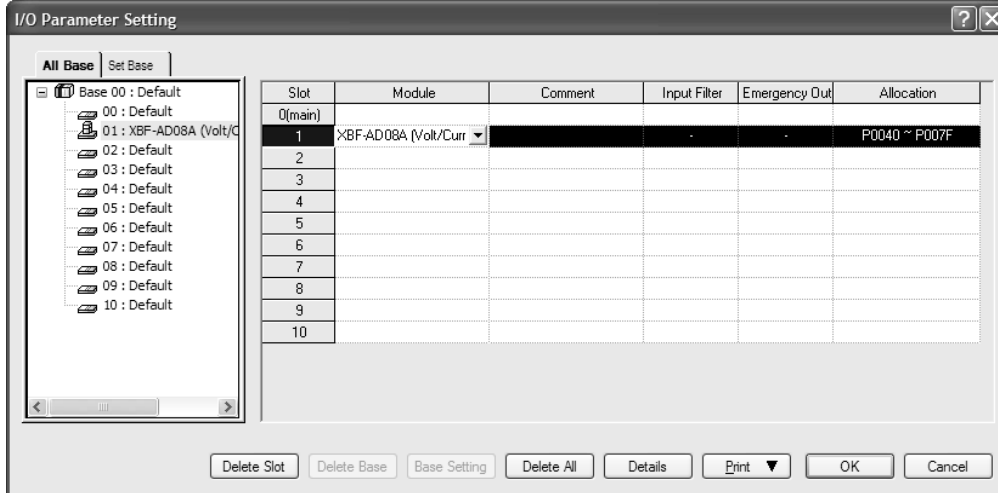

(b) Double click [Variables/Comment].

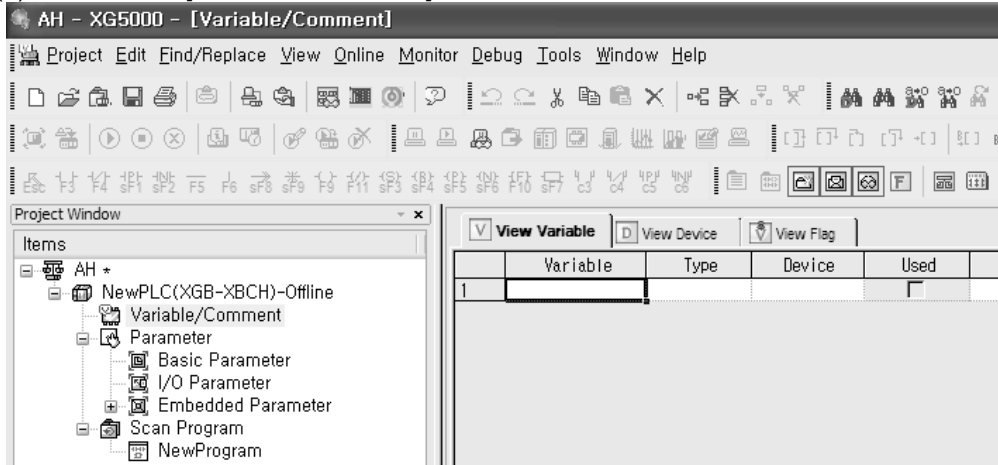

(c) In the 'Edit' menu, select 'U-Device Auto Registration (special module variable auto registration).

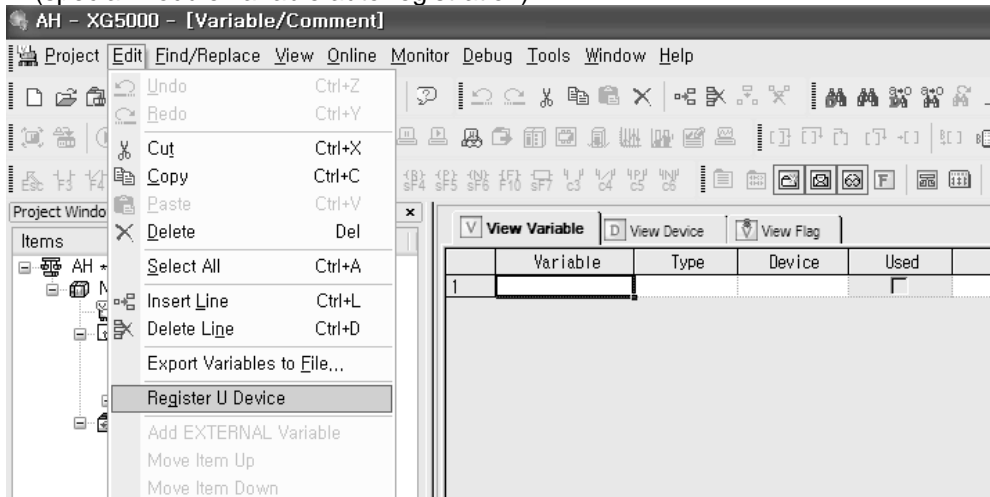

(d) Click 'Yes.'

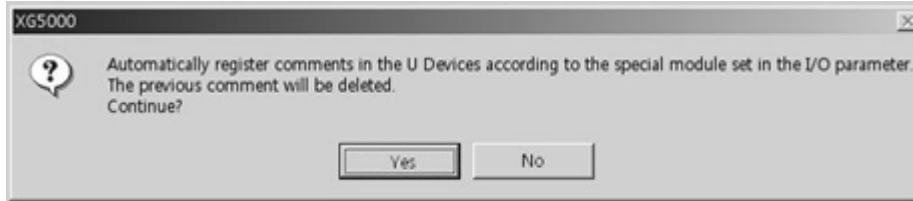

(e) Variables are registered as shown below.

View Variable   View Device   View Flag					
	Variable	Type	Device	Used	Comment
1	_01_ERR	BIT	U01.00.0	<input type="checkbox"/>	Analog Input Module: Module Error
2	_01_RDY	BIT	U01.00.F	<input type="checkbox"/>	Analog Input Module: Module Ready
3	_01_CH0_ACT	BIT	U01.01.0	<input type="checkbox"/>	Analog Input Module: CH0 Active
4	_01_CH1_ACT	BIT	U01.01.1	<input type="checkbox"/>	Analog Input Module: CH1 Active
5	_01_CH2_ACT	BIT	U01.01.2	<input type="checkbox"/>	Analog Input Module: CH2 Active
6	_01_CH3_ACT	BIT	U01.01.3	<input type="checkbox"/>	Analog Input Module: CH3 Active
7	_01_CH4_ACT	BIT	U01.01.4	<input type="checkbox"/>	Analog Input Module: CH4 Active
8	_01_CH5_ACT	BIT	U01.01.5	<input type="checkbox"/>	Analog Input Module: CH5 Active
9	_01_CH6_ACT	BIT	U01.01.6	<input type="checkbox"/>	Analog Input Module: CH6 Active
10	_01_CH7_ACT	BIT	U01.01.7	<input type="checkbox"/>	Analog Input Module: CH7 Active
11	_01_CH0_ERR	BIT	U01.01.8	<input type="checkbox"/>	Analog Input Module: CH0 Error
12	_01_CH1_ERR	BIT	U01.01.9	<input type="checkbox"/>	Analog Input Module: CH1 Error
13	_01_CH2_ERR	BIT	U01.01.A	<input type="checkbox"/>	Analog Input Module: CH2 Error
14	_01_CH3_ERR	BIT	U01.01.B	<input type="checkbox"/>	Analog Input Module: CH3 Error
15	_01_CH4_ERR	BIT	U01.01.C	<input type="checkbox"/>	Analog Input Module: CH4 Error
16	_01_CH5_ERR	BIT	U01.01.D	<input type="checkbox"/>	Analog Input Module: CH5 Error
17	_01_CH6_ERR	BIT	U01.01.E	<input type="checkbox"/>	Analog Input Module: CH6 Error

(f) In IEC types, the variables are registered as shown below.

Global Variable   Direct Variable Comment   Flag							
	Variable Kind	Variable	Type	Ad	Initi	Use	Comment
8	VAR_GLOBAL	_01_CH1_IDD	BOOL	%		<input type="checkbox"/>	Analog Input Module: CH1 Input Disconnection Flag
9	VAR_GLOBAL	_01_CH2_ACT	BOOL	%		<input type="checkbox"/>	Analog Input Module: CH2 Active
10	VAR_GLOBAL	_01_CH2_DATA	WORD	%		<input type="checkbox"/>	Analog Input Module: CH2 Output
11	VAR_GLOBAL	_01_CH2_ERR	BOOL	%		<input type="checkbox"/>	Analog Input Module: CH2 Error
12	VAR_GLOBAL	_01_CH2_IDD	BOOL	%		<input type="checkbox"/>	Analog Input Module: CH2 Input Disconnection Flag
13	VAR_GLOBAL	_01_CH3_ACT	BOOL	%		<input type="checkbox"/>	Analog Input Module: CH3 Active
14	VAR_GLOBAL	_01_CH3_DATA	WORD	%		<input type="checkbox"/>	Analog Input Module: CH3 Output
15	VAR_GLOBAL	_01_CH3_ERR	BOOL	%		<input type="checkbox"/>	Analog Input Module: CH3 Error
16	VAR_GLOBAL	_01_CH3_IDD	BOOL	%		<input type="checkbox"/>	Analog Input Module: CH3 Input Disconnection Flag
17	VAR_GLOBAL	_01_CH4_ACT	BOOL	%		<input type="checkbox"/>	Analog Input Module: CH4 Active
18	VAR_GLOBAL	_01_CH4_DATA	WORD	%		<input type="checkbox"/>	Analog Input Module: CH4 Output
19	VAR_GLOBAL	_01_CH4_ERR	BOOL	%		<input type="checkbox"/>	Analog Input Module: CH4 Error
20	VAR_GLOBAL	_01_CH4_IDD	BOOL	%		<input type="checkbox"/>	Analog Input Module: CH4 Input Disconnection Flag
21	VAR_GLOBAL	_01_CH5_ACT	BOOL	%		<input type="checkbox"/>	Analog Input Module: CH5 Active
22	VAR_GLOBAL	_01_CH5_DATA	WORD	%		<input type="checkbox"/>	Analog Input Module: CH5 Output
23	VAR_GLOBAL	_01_CH5_ERR	BOOL	%		<input type="checkbox"/>	Analog Input Module: CH5 Error
24	VAR_GLOBAL	_01_CH5_IDD	BOOL	%		<input type="checkbox"/>	Analog Input Module: CH5 Input Disconnection Flag
25	VAR_GLOBAL	_01_CH6_ACT	BOOL	%		<input type="checkbox"/>	Analog Input Module: CH6 Active
26	VAR_GLOBAL	_01_CH6_DATA	WORD	%		<input type="checkbox"/>	Analog Input Module: CH6 Output

(2) Saving Variables

- (a) The contents in the 'View Variables' tab can be saved in a text file.
- (b) In the 'Edit' menu, select 'Save as Text File.'
- (c) The contents in the 'View Variables' tab are saved in a text file.



(3) Viewing Variables in Program

The figures below present examples of use in XGB “S” and “H” types.

(a) Below is an exemplary program for XG5000.

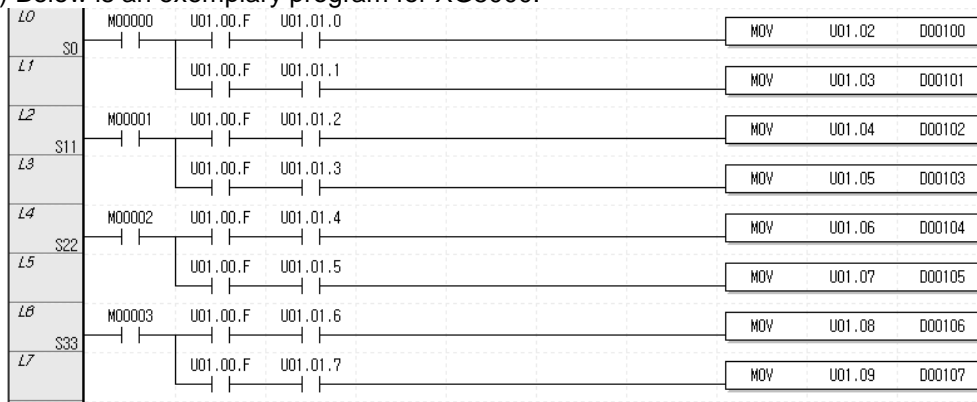

(b) In the 'View' menu, click 'View Variables.' The devices are changed into variables.

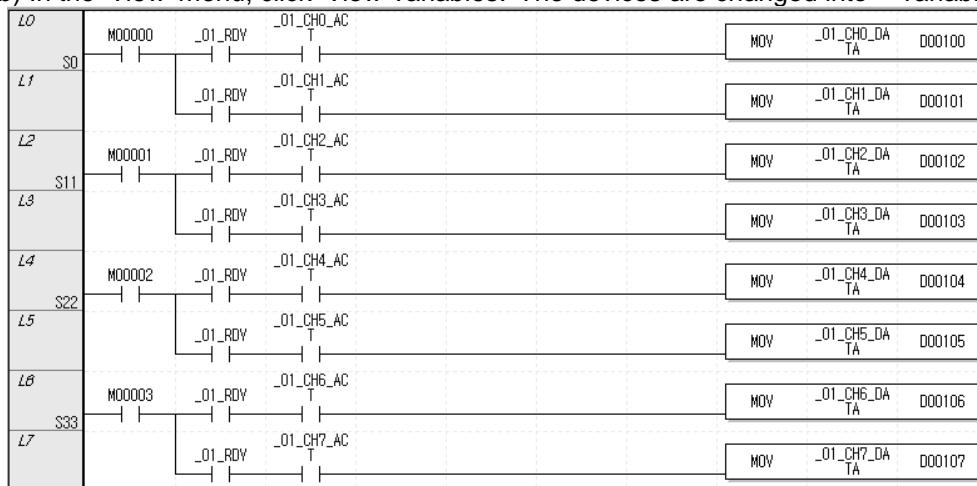

(c) In the 'View' menu, click 'View Device/Variables' to look up the devices and variables at the same time.

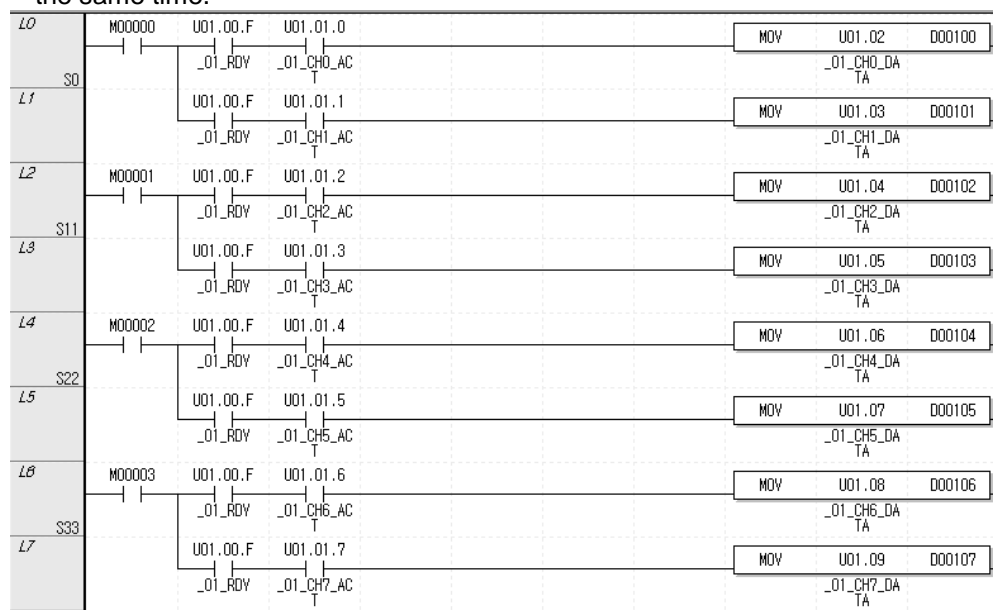

(d) In the 'View' menu, click 'View Device/Description' to look up the devices and descriptions at the same time.

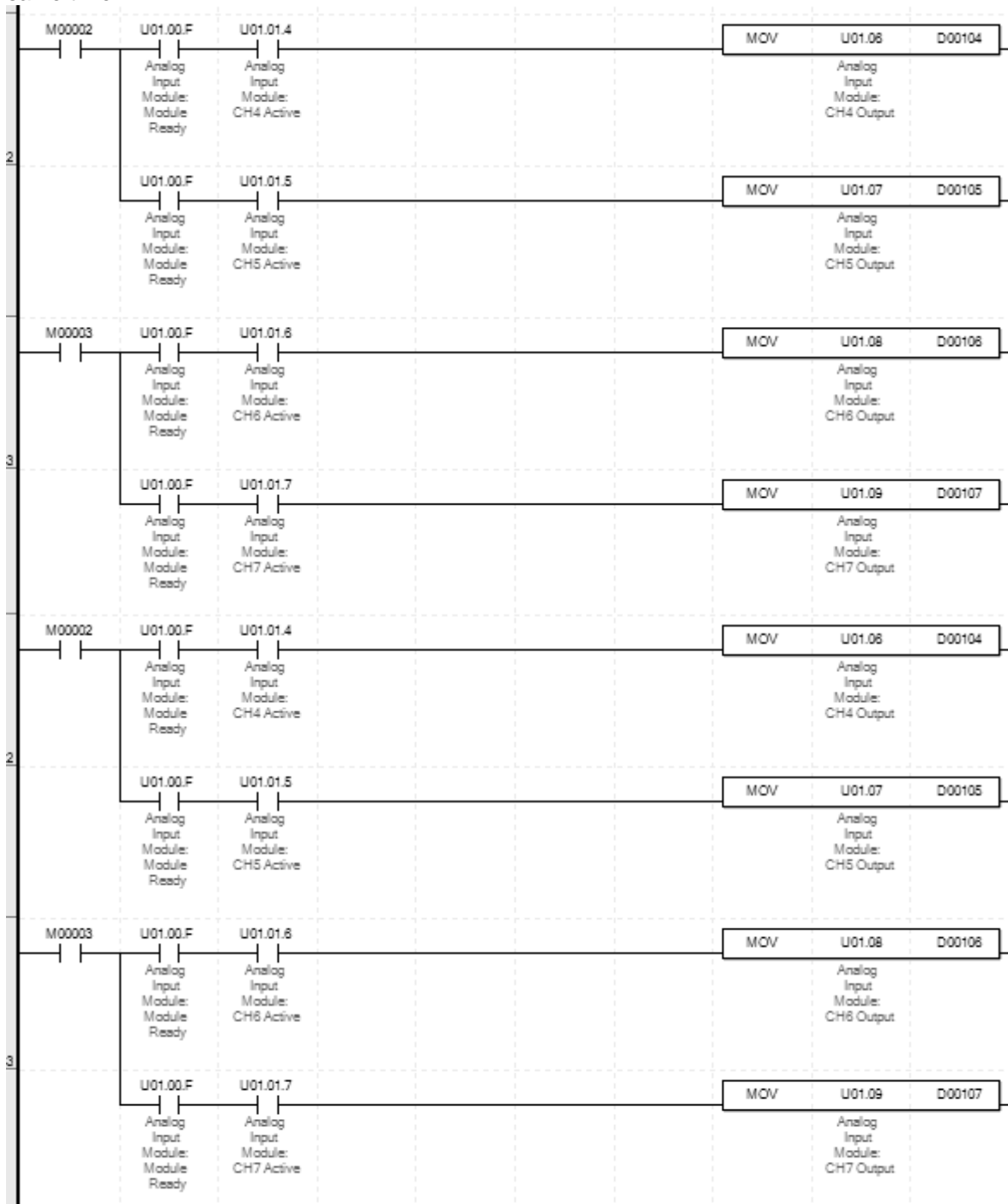

(e) For IEC type also, as shown in Fig. (a) ~ (d), you can look up variables with diversified options in the 'View' menu. The figure below is the case of an IEC type with which the 'View Variables/Comment' option.

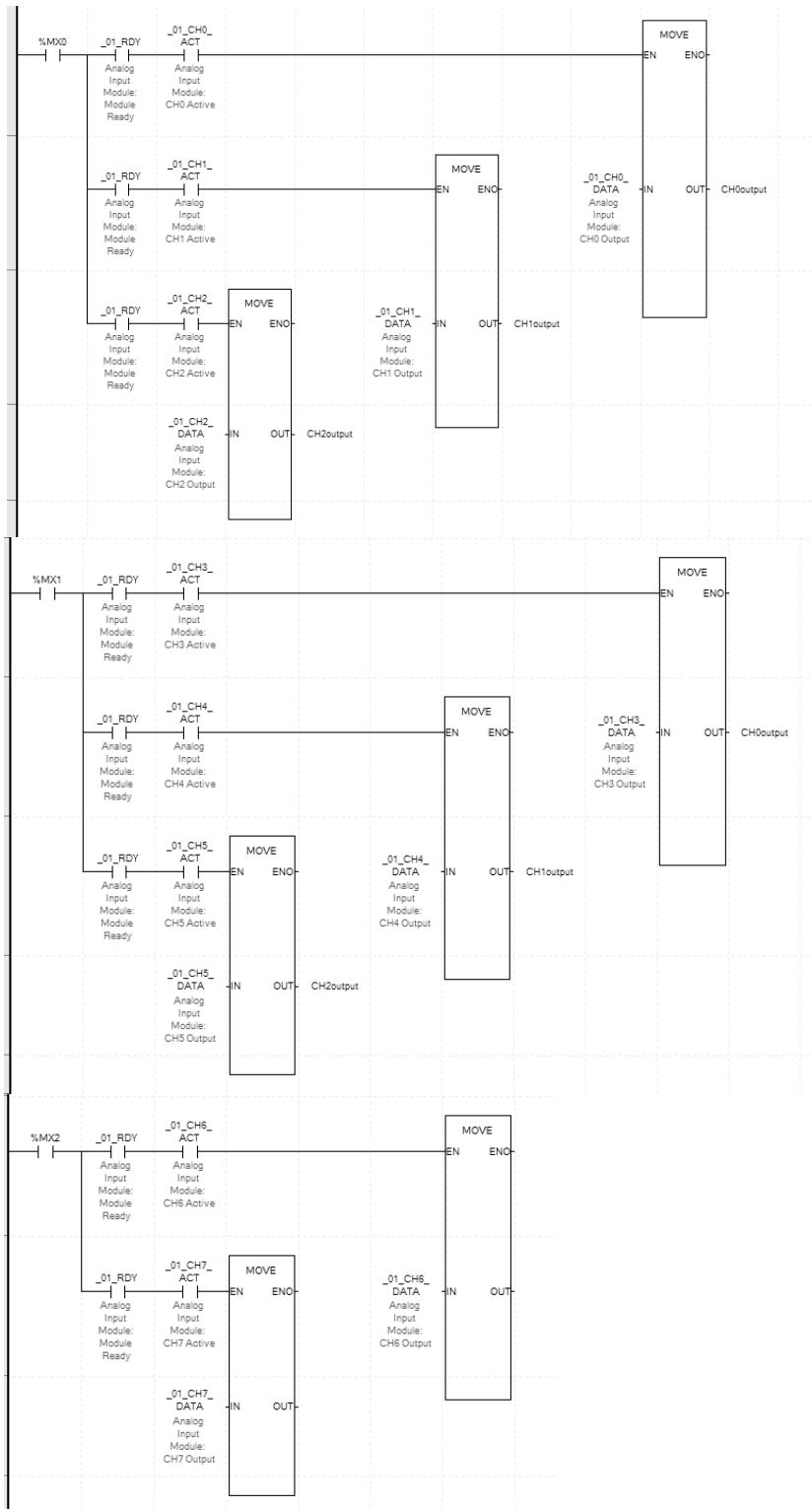

## 7.11 Configuration and Function of Internal Memory

An analog mix module has internal memory for data communication with XGB base unit.

### 7.11.1 Analog Data I/O Area

The table below presents the analog data I/O area.

Variable	Type	Device assignment		Description	Read/Write	Signal direction		
		“S” or “H” type	IEC type					
_0y_ERR	BIT	U0y.00.0	%UX0.y.0	Module Error	Read	AD08A → CPU		
_0y_RDY	BIT	U0y.00.F	%UX0.y.15	Module Ready				
_0y_CH0_ACT	BIT	U0y.01.0	%UX0.y.16	CH0 Active	Read	AD08A → CPU		
_0y_CH1_ACT	BIT	U0y.01.1	%UX0.y.17	CH1 Active				
_0y_CH2_ACT	BIT	U0y.01.2	%UX0.y.18	CH2 Active				
_0y_CH3_ACT	BIT	U0y.01.3	%UX0.y.19	CH3 Active				
_0y_CH4_ACT	BIT	U0y.01.4	%UX0.y.20	CH4 Active				
_0y_CH5_ACT	BIT	U0y.01.5	%UX0.y.21	CH5 Active				
_0y_CH6_ACT	BIT	U0y.01.6	%UX0.y.22	CH6 Active				
_0y_CH7_ACT	BIT	U0y.01.7	%UX0.y.23	CH7 Active	Read	AD08A → CPU		
_0y_CH0_ERR	BIT	U0y.01.8	%UX0.y.24	CH0 error				
_0y_CH1_ERR	BIT	U0y.01.9	%UX0.y.25	CH1 error				
_0y_CH2_ERR	BIT	U0y.01.A	%UX0.y.26	CH2 error				
_0y_CH3_ERR	BIT	U0y.01.B	%UX0.y.27	CH3 error				
_0y_CH4_ERR	BIT	U0y.01.C	%UX0.y.28	CH4 error				
_0y_CH5_ERR	BIT	U0y.01.D	%UX0.y.29	CH5 error				
_0y_CH6_ERR	BIT	U0y.01.E	%UX0.y.30	CH6 error	Read	AD08A → CPU		
_0y_CH7_ERR	BIT	U0y.01.F	%UX0.y.31	CH7 error				
_0y_CH0_DATA	WORD	U0y.02	%UW0.y.2	CH0 Output				
_0y_CH1_DATA	WORD	U0y.03	%UW0.y.3	CH1 Output				
_0y_CH2_DATA	WORD	U0y.04	%UW0.y.4	CH2 Output				
_0y_CH3_DATA	WORD	U0y.05	%UW0.y.5	CH3 Output				
_0y_CH4_DATA	WORD	U0y.06	%UW0.y.6	CH4 Output				
_0y_CH5_DATA	WORD	U0y.07	%UW0.y.7	CH5 Output	Read	AD08A → CPU		
_0y_CH6_DATA	WORD	U0y.08	%UW0.y.8	CH6 Output				
_0y_CH7_DATA	WORD	U0y.09	%UW0.y.9	CH7 Output				
_0y_CH0_IDD	BIT	U0y.10.0	%UX0.y.160	CH0 Disconnection flag			Read	AD08A → CPU
_0y_CH1_IDD	BIT	U0y.10.1	%UX0.y.161	CH1 Disconnection flag				
_0y_CH2_IDD	BIT	U0y.10.2	%UX0.y.162	CH2 Disconnection flag				
_0y_CH3_IDD	BIT	U0y.10.3	%UX0.y.163	CH3 Disconnection flag				
_0y_CH4_IDD	BIT	U0y.10.4	%UX0.y.164	CH4 Disconnection flag				
_0y_CH5_IDD	BIT	U0y.10.5	%UX0.y.165	CH5 Disconnection flag				
_0y_CH6_IDD	BIT	U0y.10.6	%UX0.y.166	CH6 Disconnection flag				
_0y_CH7_IDD	BIT	U0y.10.7	%UX0.y.167	CH7 Disconnection flag	Read/Write	AD08A ↔ CPU		
_0y_ERR_CLR	BIT	U0y.11.0	%UX0.y.176	Error Clear Request				

## Chapter 7 Analog Input (XBF-AD08A)

- In the device allocation, the small letter 'y' is the No. of the slot where the module is installed.
- For example, to read the 'CH3 Output' of the analog module installed in the slot 4, write in U04.05.  
(%UW0.4.5 for IEC types)

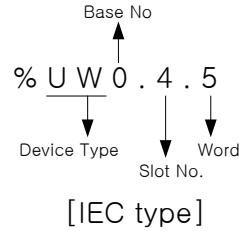
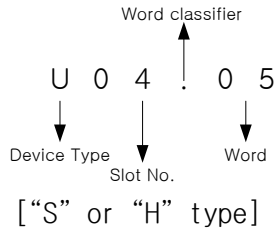

- (1) Module Ready/Error Flag ( ) is for IEC types, y: slot No.)
- (a) U0y.00.F (%UX0.y.15): at power on or reset of PLC CPU, turns on when the analog I/O conversion is ready, and analog conversion is performed.
- (b) U0y.00.0(%UX0.y.0): the flag indicating the error status of A/D conversion module.

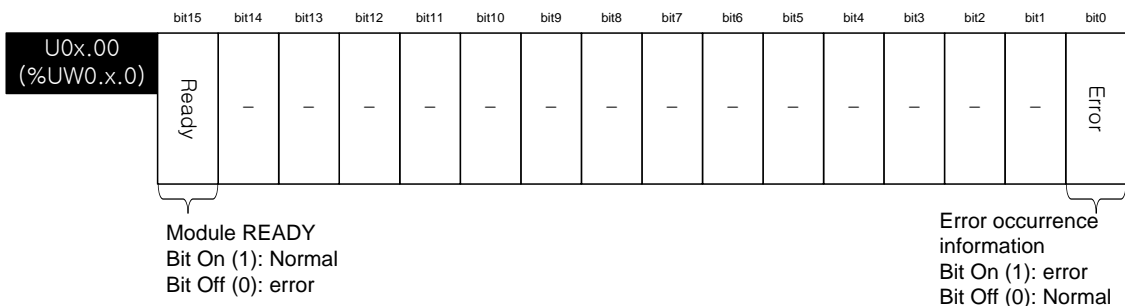

- (2) Operation channel information ( ) is for IEC types, x: slot No.)
- This is the area for storing the operation information, input wire open detection, and channel error information by channel.
- ※ The base No. of the XGB PLC is 0.

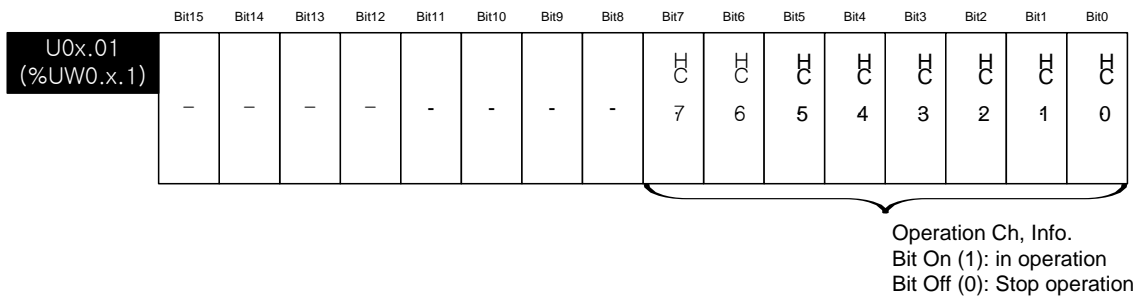

(3) Digital Output Values ( ( ) is for IEC types, y: slot No.)

(a) A/D converted digital values are outputted to buffer memory address U0y.02 ~ U0y.09 (%UW0.y.2~ %UW0.y.9) by channel-basis.

(b) Digital output values are saved in 16-bit binary figures.

※ The base No. of the XGB PLC is 0.

	비트15	비트14	비트13	비트12	비트11	비트10	비트9	비트8	비트7	비트6	비트5	비트4	비트3	비트2	비트1	비트0
U0y.02 (%UW0.y.2)	CH 0 Output															
U0y.03 (%UW0.y.3)	CH 1 Output															
U0y.04 (%UW0.y.4)	CH 2 Output															
U0y.05 (%UW0.y.5)	CH 3 Output															
U0y.06 (%UW0.y.6)	CH 4 Output															
U0y.07 (%UW0.y.7)	CH 5 Output															
U0y.08 (%UW0.y.8)	CH 6 Output															
U0y.09 (%UW0.y.9)	CH 7 Output															

## 7.11.2 Operation Parameter Setting Area

The operation parameter setting area of the analog mix module is as follows.

Memory Add.	Description	Setting	R/W	Command
0	Appoint operating channel	Bit Off (0): stop, Bit ON (1): run	R/W	PUT/GET
1	I/O range setting (CH0~CH3)	I/O range setting (bit) 0000: 4 ~ 20 mA 0001: 0 ~ 20 mA 0010: 1 ~ 5 V	R/W	
2	I/O range setting (CH4~CH7)	0011: 0 ~ 5 V 0100: 0 ~ 10 V	R/W	
3	Output data type setting	Input data type setting (bit) 00: 0 ~ 4000 01: -2000 ~ 2000 10: precise value 11: 0 ~ 1000 - In case of precise value 4 ~ 20 mA: 400 ~ 2000 0 ~ 20 mA: 0 ~ 2000 1 ~ 5 V: 100 ~ 500 0 ~ 5 V: 0 ~ 500 0 ~ 10 V: 0 ~ 1000	R/W	
4	CH0 Filter constant	0 or 4 ~ 64000	R/W	
5	CH1 Filter constant			
6	CH2 Filter constant			
7	CH3 Filter constant			
8	CH4 Filter constant			
9	CH5 Filter constant			
10	CH6 Filter constant			
11	CH7 Filter constant			
12	Average processing method	Specifies average processing method (2bit per channel) 00: Sampling processing 01: Time average processing 10: Count average processing 11: Moving average processing	R/W	
13	CH0 average value	Time average: 4 ~ 16000 [ms] Count average: 2 ~ 64000 [times] Moving average: 2 ~ 100	R/W	
14	CH1 average value			
15	CH2 average value			
16	CH3 average value			
17	CH4 average value			
18	CH5 average value			
19	CH6 average value			
20	CH7 average value			
21	Error information	Error information (Decimal, # channel n0.) 0-7: CH0-7 10#: error in channel range 20#: error in channel filter value 30#: error in channel average value	R	GET

**Note**

- (1) If the memory address 0~8 area is entered with values different from the setting U0x.01.8~U0x.01.B (setting error representative flag, for IEC type, %UX0.x.24~%UX0.x.27) is ON and runs with default values. The error information is displayed in the setting error information are (No. 9).
- (2) System areas (after No. 10) are read/write protected.  
Changing these areas may cause malfunction or failure of the product.

(1) Operating Channel Setting

The default setting for operating channel is 'Stop.'

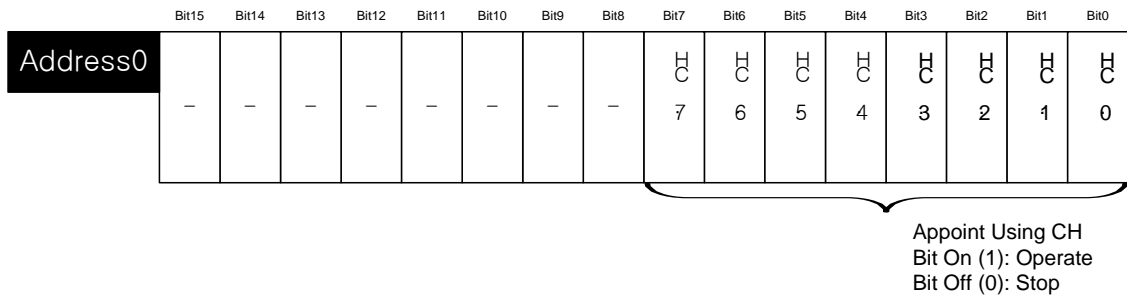

(2) Input Range Setting

(a) The analog input voltage range is DC 1~5V, DC 0~5V, DC 0~10V, and analog current input range is DC 4~20mA, DC 0~20mA.

(b) Default range is DC 4~20mA.

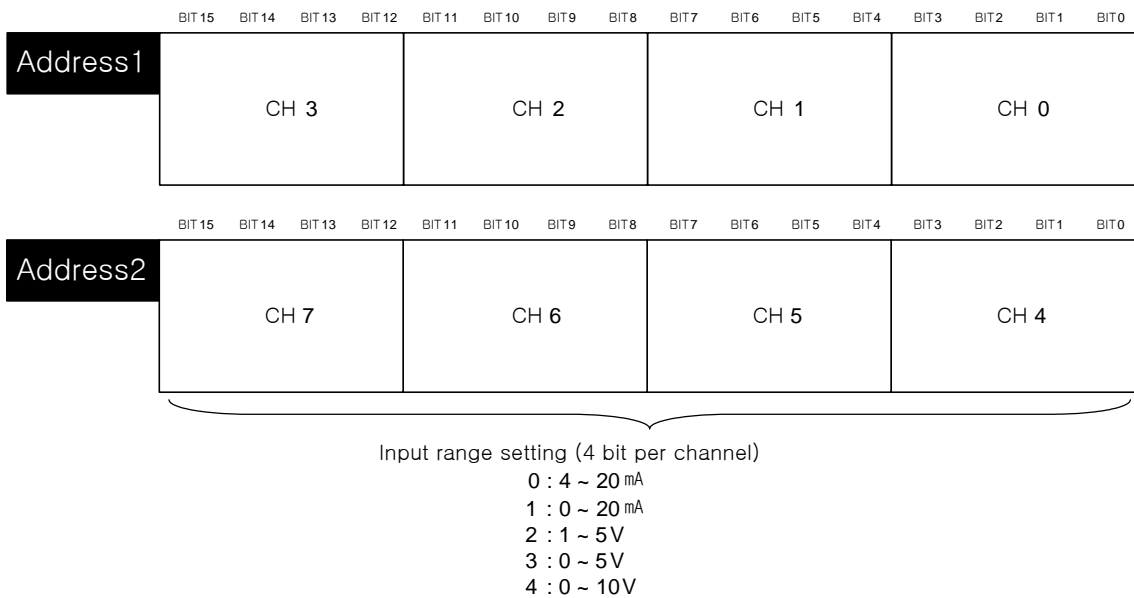

(3) I/O Data Type Setting

(a) I/O data type can be set up for each channel.

(b) If the I/O data type is not set up, all the channels are processed in 0~4000 range.

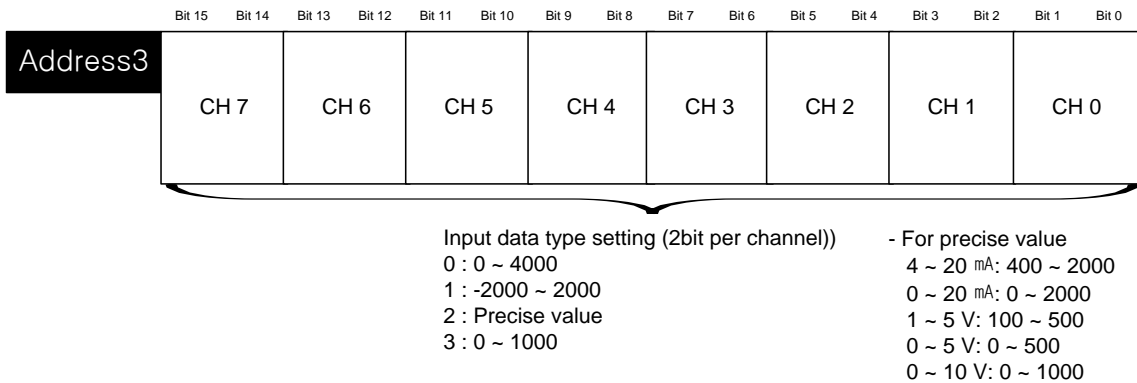



(4) Filter Constant Setting

- (a) If set to 0, no filtration is processed.
- (b) Default setting is 0 – no filtration process.

	Bit 15	Bit 14	Bit 13	Bit 12	Bit 11	Bit 10	Bit 9	Bit 8	Bit 7	Bit 6	Bit 5	Bit 4	Bit 3	Bit 2	Bit 1	Bit 0
Address4	CH 0 filter constant (0 or 4~64000ms)															
Address5	CH 1 filter constant (0 or 4~64000ms)															
Address6	CH 2 filter constant (0 or 4~64000ms)															
Address7	CH 3 filter constant (0 or 4~64000ms)															
Address8	CH 4 filter constant (0 or 4~64000ms)															
Address9	CH 5 filter constant (0 or 4~64000ms)															
Address10	CH 6 filter constant (0 or 4~64000ms)															
Address11	CH 7 filter constant (0 or 4~64000ms)															

(5) Averaging Method Setting

- (a) Averaging method can be one of; time average, count average, moving average.
- (b) Default setting is no averaging throughout the channels.

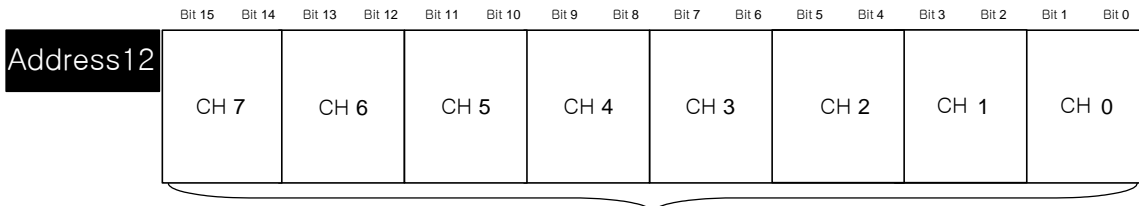

Average processing (4 bit per channel)

- 0 : Sampling Processing
- 1 : Time average processing
- 2 : Count average processing
- 3 : Moving average processing

(6) Average Value Setting

- (a) Set up average values in accordance with the setting area of the averaging method.
- (b) If the average value is out of setting range, averaging is not applied.

	Bit 15	Bit 14	Bit 13	Bit 12	Bit 11	Bit 10	Bit 9	Bit 8	Bit 7	Bit 6	Bit 5	Bit 4	Bit 3	Bit 2	Bit 1	Bit 0
Address13	CH 0 average value															
Address14	CH 1 average value															
Address15	CH 2 average value															
Address16	CH 3 average value															
Address17	CH 4 average value															
Address18	CH 5 average value															
Address19	CH 6 average value															
Address20	CH 7 average value															

Input channel # average value setting  
 Time average : 4 ~ 16000[ms]  
 Count average : 2 ~ 64000[times]  
 Moving average: 2 ~ 100

(7) Error Code (Address 21)

- (a) Saves the error code detected by the analog mix module.
- (b) The types and descriptions of the error are as follows.

	Bit15	Bit14	Bit13	Bit12	Bit11	Bit10	Bit9	Bit8	Bit7	Bit6	Bit5	Bit4	Bit3	Bit2	Bit1	Bit0
Address21	Set-up error information															

Type	Error code	LED	Description	Error code Priority	Remark
Error	10#	LED flickering 1s intervals	Channel range set-up error	1	# channel no. CH 0~7
	20#		Channel filter constant set-up error	2	
	30#		Channel average value set-up error	3	

- (c) In case of plural errors, the code with higher priority order will be saved.

(9) System Area (after Address 22)

- (a) System area (after address 22) is read/write protected.

 <b>Caution</b>	Modifying this area can cause malfunction of failure of product.
--	--

## 7.12 Example Program

- (1) This sample program sets up operating parameters of analog input module.
- (2) Initial settings are saved in the internal memory of the module by input by once.
- (3) The sample program below controls the output data of the analog input module at slot #1 and check open wire.

### 7.12.1 Example of [I/O Parameter] Usage

(1) I/O Parameter Setting Window

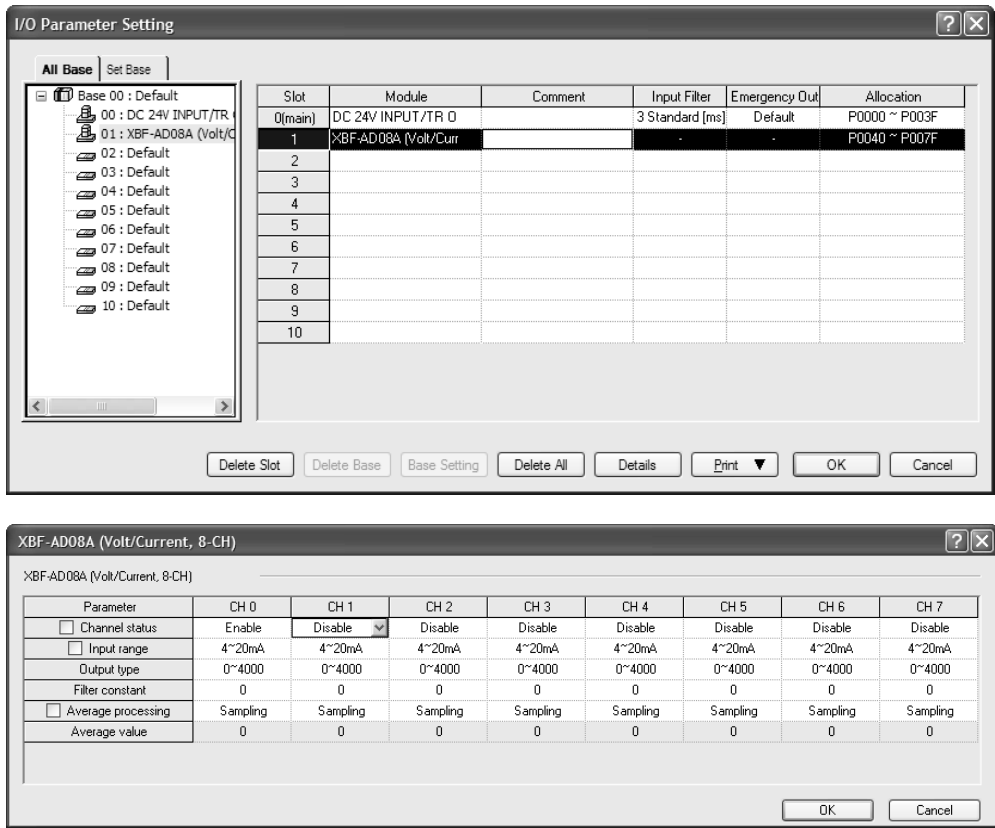

(a) Input Channel 0 is set to operating channel and input range is set to 4~20mA.

(2) Sample Program

CH0 program

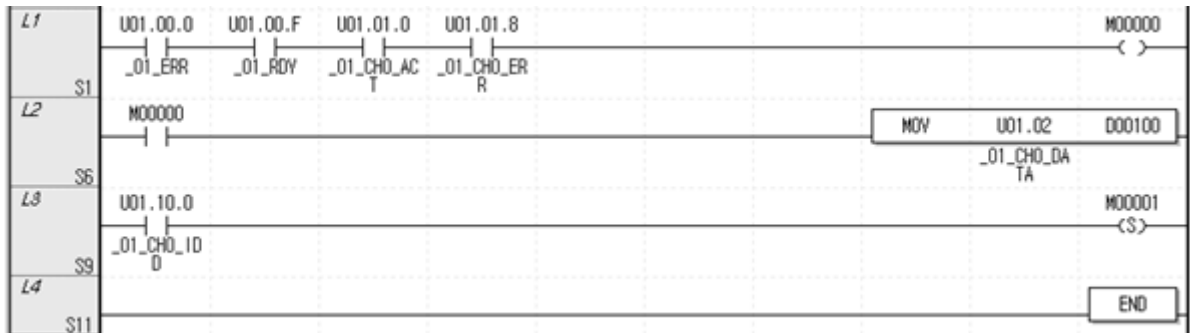

- (a) When the module is in normal operation, M0000 is turned On.  
 U01.00.0 (Module Error) = Off  
 U01.00.F (Module Ready) = On  
 U01.01.0 (Input Channel 0 in-operation) = On  
 U01.01.8 (Input Channel 0 Error) = Off
- (b) When M0000 is ON, Input Channel 0 Converted Value(U01.02) is moved to D00100.
- (c) If open-wire error occurs in channel 0, U01.10.0 (channel 0 open-wire) is ON, and M0001 bit is set.

(3) Sample Program (IEC type)

Output CH0 program

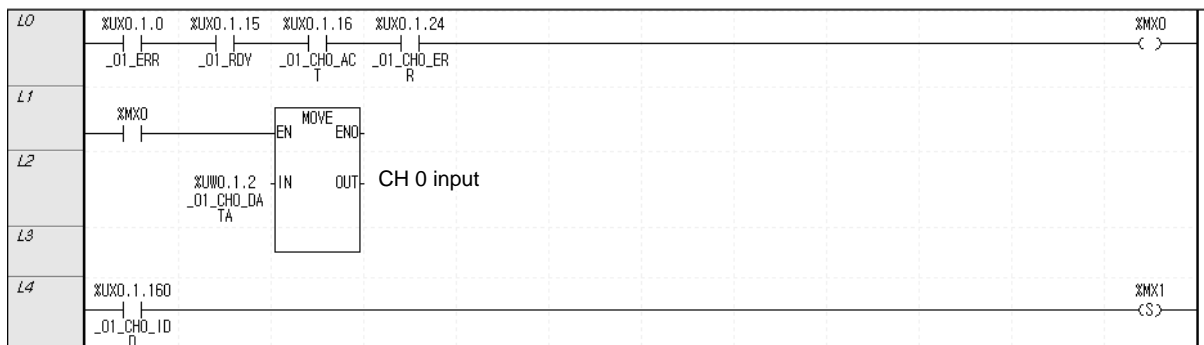

- (a) When the module is in normal operation, %MX0 is turned ON.  
 %UX0.1.0(Module Error) = Off  
 %UX0.1.15(Module Ready) = On  
 %UX0.1.16(Channel 0 in-operation) = On  
 %UX0.1.24(Channel 0 Error) = Off
- (b) When %MX0 is ON, Input Channel 0 Converted Value(%UW0.1.4) is transferred to "CH 0 Input" variable.
- (c) If open-wire error occurs at Channel 0, %UX0.1.160 (Channel 0 open) turns ON and %MX1 bit is set.

## 7.13 Troubleshooting

This section describes methods for identifying the troubles which may occur during the operation of analog input module, and their solutions.

### 7.13.1 LED Indication for Error

An analog input module has one INPUT LED to indicate error status of the module.

Item	Normal State	Channel Open (Input)	Parameter Setting Error	Module H/W Failure (Serious Failure)
LED	On	Flickering 1s intervals	Flickering 1s intervals (input parameter setting error)	Flickering 0.2s Intervals
Module Behavior	All functions are normal	All functions are performed. Indicates min. input value	All functions work at default parameter setting	Module cannot function
Action	-	Check input wire	Check parameter setting	Request for A/S

### 7.13.2 Checking Module Condition

XG5000's system monitor enables verification of the analog mix module conditions (module type, module information, OS version).

(1) Procedure

The verification can be done in 2 ways;

- (a) [Monitor] -> [System Monitor] -> mouse right click on module icon -> [Module Information]
- (b) [Monitor] -> [System Monitor] -> double click module icon.

(2) Module Information

- (a) Module type: shows the information on the present module.
- (b) Module information: shows the OS version of the module.
- (c) OS version: shows release date of Module OS.

### 7.13.3 Troubleshooting

(1) INPUT LED is off.

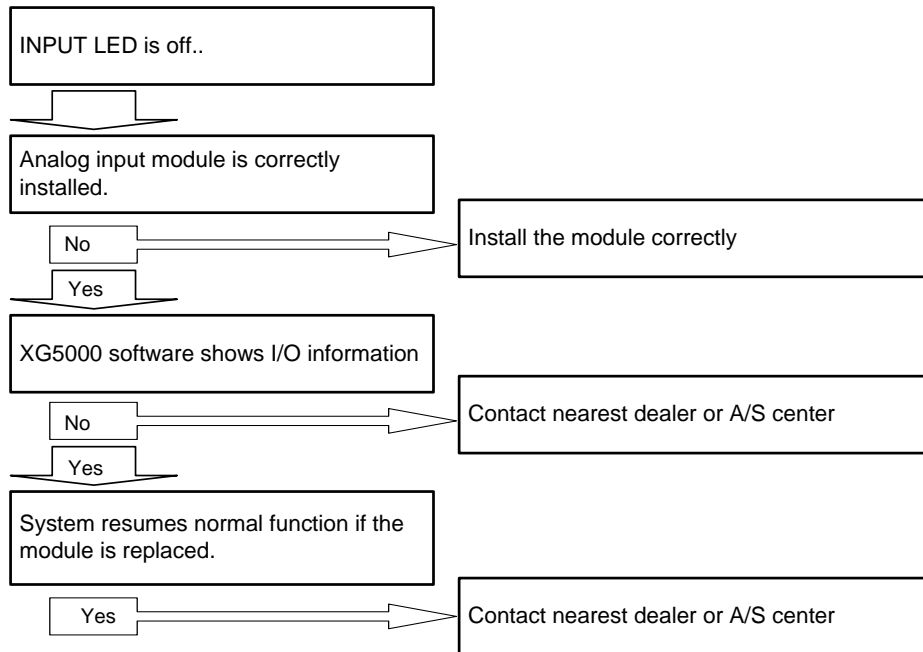

(2) LED flickering.

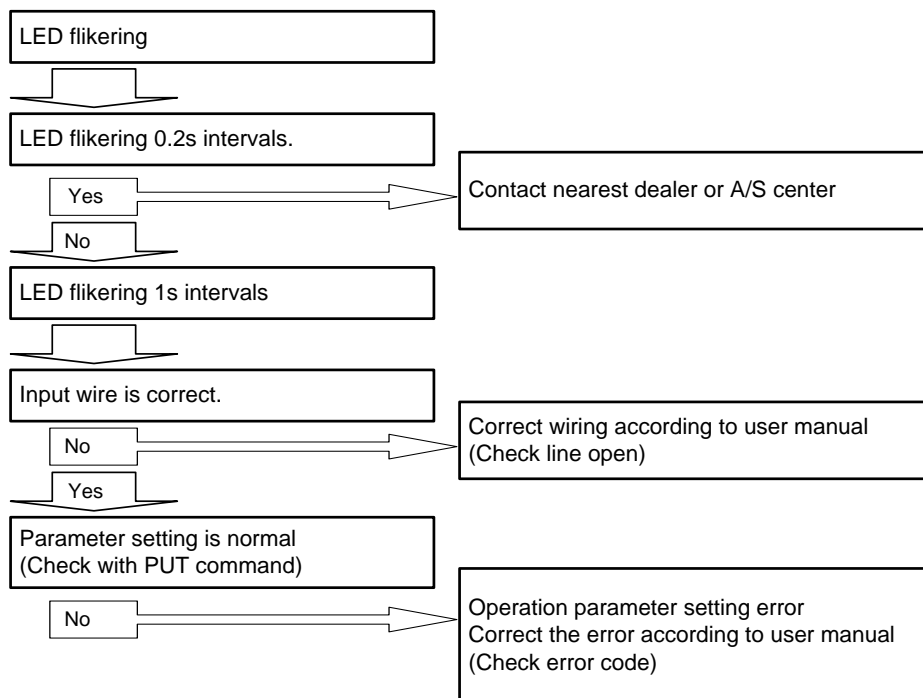

(3) Analog input value is abnormal.

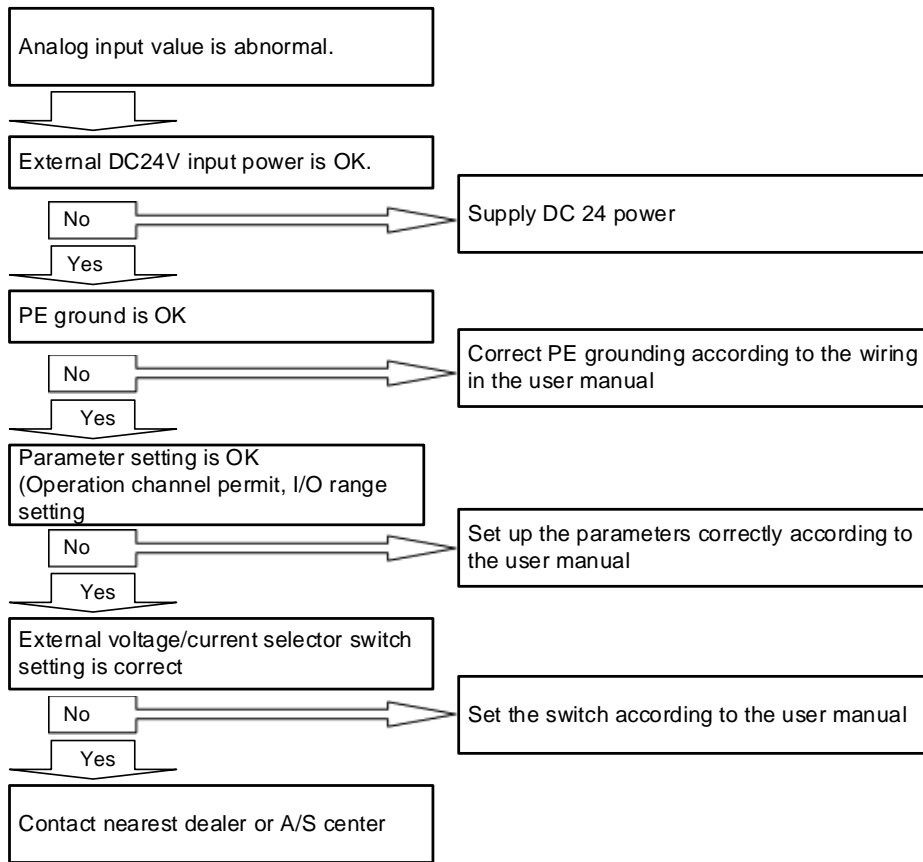





# Chapter 8 Analog Input Option Board

## 8.1 Setting Sequence before operation

Before using the analog input option board, follow steps below.

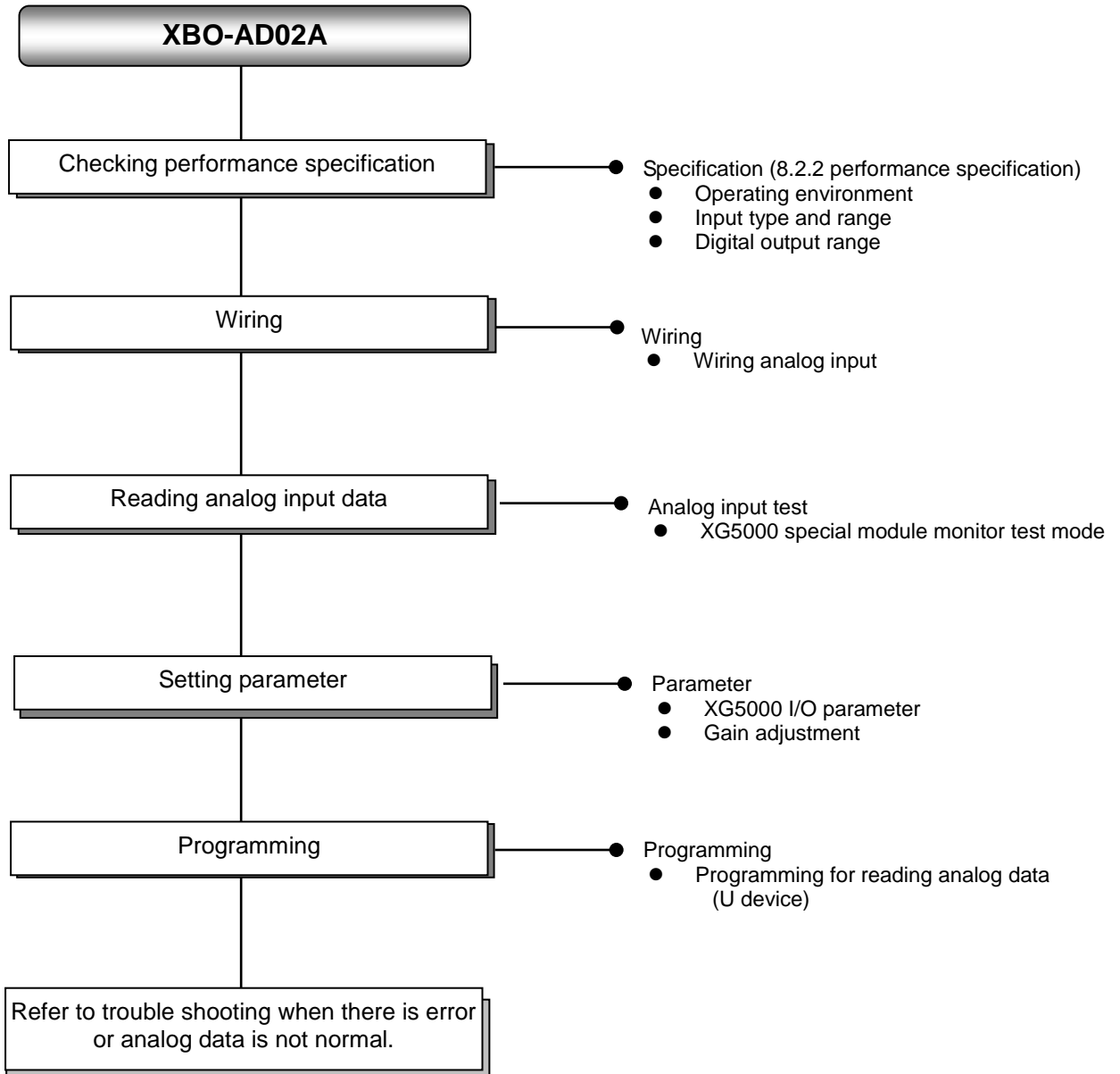

## 8.2 Specifications

### 8.2.1 General specifications

General specifications are as follows.

No.	Item	Specifications	Related specifications			
1	Ambient temperature	0°C ~ +55°C	-			
2	Storage temperature	-25°C ~ +70°C	-			
3	Ambient humidity	5 ~ 95%RH (Non-condensing)	-			
4	Storage humidity	5 ~ 95%RH (Non-condensing)	-			
5	Vibration resistance	Occasional vibration		-	IEC61131-2	
		Frequency	Acceleration	Amplitude		How many times
		5 ≤ f < 8.4 Hz	-	3.5 mm		10 times each directions (X, Y and Z)
		8.4 ≤ f ≤ 150 Hz	9.8 m/s <sup>2</sup> (1G)	-		
		For continuous vibration				
		Frequency	Acceleration	Amplitude		
		5 ≤ f < 8.4 Hz	-	1.75 mm		
8.4 ≤ f ≤ 150 Hz	4.9 m/s <sup>2</sup> (0.5G)	-				
6	Shock resistance	<ul style="list-style-type: none"> <li>Peak acceleration: 147 m/s<sup>2</sup>(15G)</li> <li>Duration: 11ms</li> <li>Half-sine, 3 times each direction per each axis</li> </ul>	IEC61131-2			
7	Noise resistance	Square wave Impulse noise	AC: ± 1,500V DC: ± 900V	LS ELECTRIC standard		
		Electrostatic discharge	Voltage : 4kV (contact discharging)	IEC 61131-2, IEC 61000-4-2		
		Radiated electromagnetic field noise	80 ~ 1,000 MHz, 10V/m	IEC 61131-2, IEC 61000-4-3		
		Fast transient /bust noise	Segment Voltage	Power supply module 2kV	Digital/analog input/output communication interface 1kV	IEC 61131-2, IEC 61000-4-4
8	Environment	Free from corrosive gasses and excessive dust	-			
9	Altitude	Up to 2,000 ms	-			
10	Pollution degree	Less than equal to 2	-			
11	Cooling	Air-cooling	-			

8.2.2 Performance specifications

Performance specifications are as follows.

Items		Performance specification		
Number of channel		2 channels		
Analog input range	Type	Voltage	Current	
	Range	DC 0 ~ 10V (Input resistance: 1 MΩ Min.)	DC 4 ~ 20mA DC 0 ~ 20mA (Input resistance 250 Ω)	
		Set by external voltage/current selector switch after being set at user program or I/O parameter per each channel		
Digital output	Type	12 bit binary data		
	Range	Unsigned value	0 ~ 4000	
		Signed value	-2000 ~ 2000	
		Precise value	0 ~ 1000 (DC 0 ~ 10V)	400 ~ 2000 (DC 4 ~ 20mA) 0 ~ 2000 (DC 0 ~ 20mA)
Percentile value		0 ~ 1000		
Max. resolution		1/4000 (DC 4~20mA: 1/3200)		
		2.5mV (DC 0~10V)	5μA (DC 0~20mA) 0 ~ 2000 (DC 0 ~ 20mA)	
Accuracy		±1.0% or less		
Max. conversion speed		1ms/channel + scan time		
Absolute max. input		DC +12V / -10V	DC ±25mA	
Additional function	Average function	Count average (2 ~ 64,000 times)		
	Gain adjustment function	Gain adjustment (-40~40)		
Insulation method		No insulation between channels No insulation between input terminal and PLC main unit		
Input terminal		5 - point terminal block		
I/O points occupied		Fixed type: 64 points		
Supply power		Inner DC 5V		
Consumption current		50mA		
Weight		20g		

Note1) In order to use analog input option board, the following version is needed.

Main unit	Version information
XBC E type	V1.1 or above
XBC S type	V1.1 or above
XBC SU type	V1.0 or above
XEC E type	V1.0 or above
XEC SU type	V1.0 or above
XG5000	V.3.61 or above

Note2) Offset/gain value on the analog input range can be adjusted at XG5000- I/O parameter

### 8.3 Name of part and function

Respective designations of the parts are as described below.

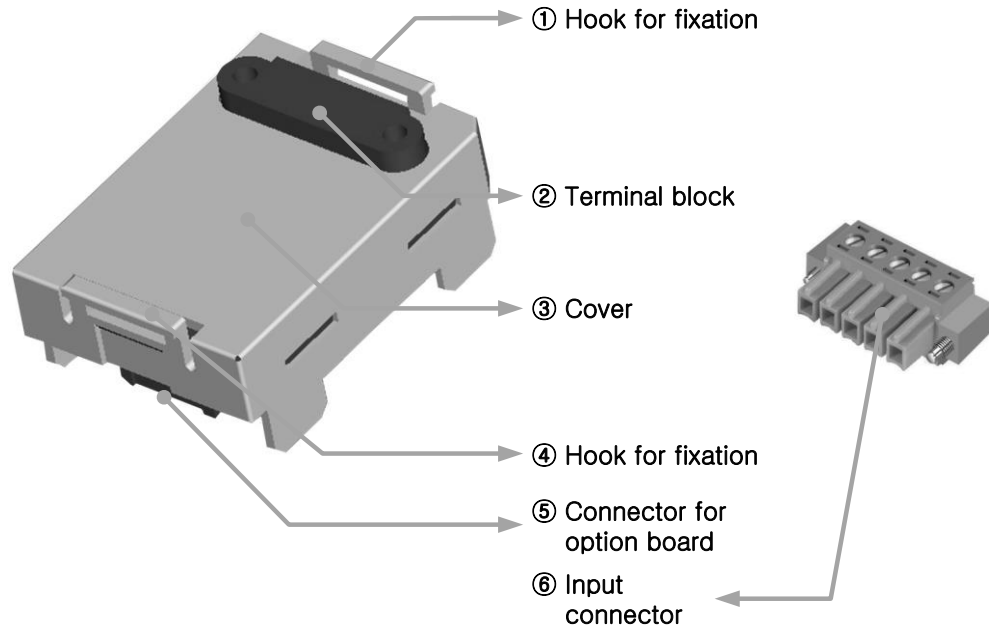

No.	Name	Description
①	Hook for fixation	▶ Hook for fixing the option board to main unit
②	Terminal block	▶ Wiring terminal block to connect with external device (Analog input)
③	Cover	▶ Option board cover
④	Hook for fixation	▶ Hook for fixing the option board to main unit
⑤	Connector for option board	▶ Connection connector for connecting the option board to the main unit
⑥	Input connector	▶ Wiring connector for connecting with the external device

## 8.4 Characteristic of I/O conversion

The input ranges of voltage and current can be set up per channel with user program or I/O parameters. The output types of digital data are defined as follows.

- (1) Unsigned Value
- (2) Signed Value
- (3) Precise Value
- (4) Percentile Value

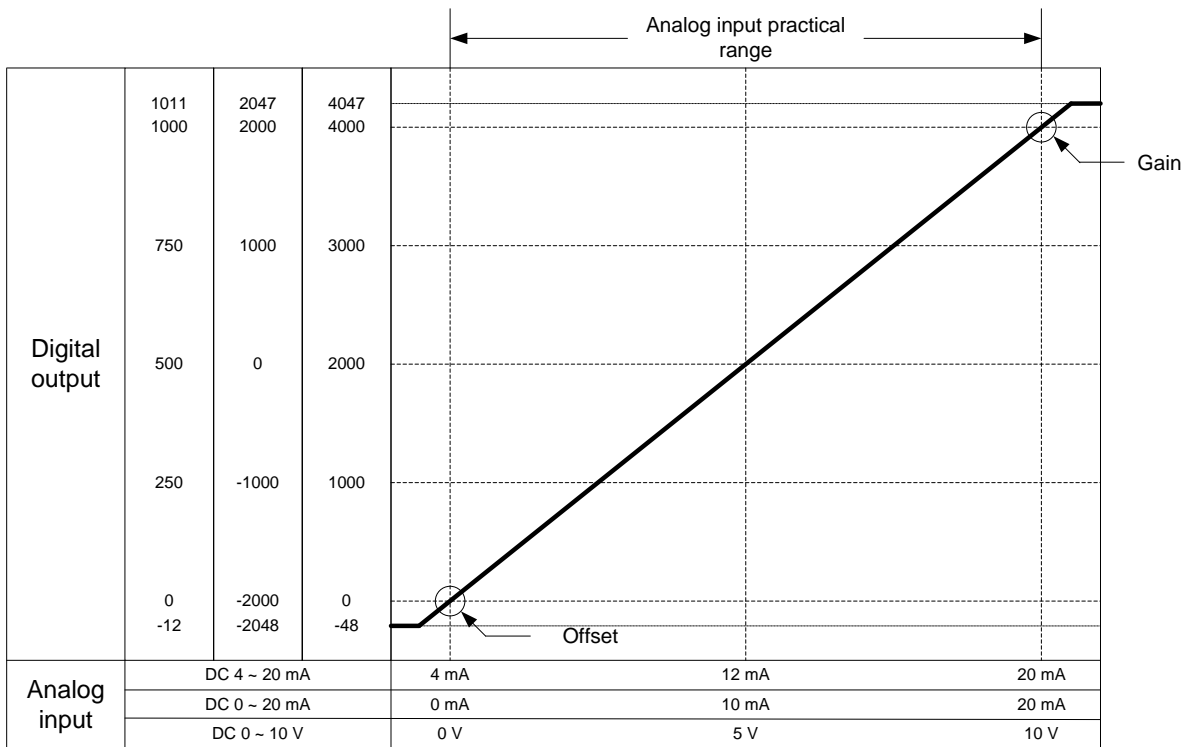

(1) DC 4 ~ 20mA Range Input

Digital Output Range	Analog Input Current (mA)						
	3.81	4	8	12	16	20	20.18
Unsigned Value (0 ~ 4000)	-48	0	1000	2000	3000	4000	4047
Signed Value (-2000 ~ 2000)	-2048	-2000	-1000	0	1000	2000	2047
Precise Value (400 ~ 2000)	381	400	800	1200	1600	2000	2018
Percentile Value(0 ~ 1000)	-12	0	250	500	750	1000	1011

(2) DC 0 ~ 20mA Range Input

Digital Output Range	Analog Input Current (mA)						
	-0.24	0	5	10	15	20	20.23
Unsigned Value (0 ~ 4000)	-48	0	1000	2000	3000	4000	4047
Signed Value (-2000 ~ 2000)	-2048	-2000	-1000	0	1000	2000	2047
Precise Value (0 ~ 2000)	-24	0	500	1000	1500	2000	2023
Percentile Value(0 ~ 1000)	-12	0	250	500	750	1000	1011

(3) DC 0 ~ 10V Range Input

Digital Output Range	Analog Input Voltage (V)						
	-0.12	0	2.5	5	7.5	10	10.11
Unsigned Value (0 ~ 4000)	-48	0	1000	2000	3000	4000	4047
Signed Value (-2000 ~ 2000)	-2048	-2000	-1000	0	1000	2000	2047
Precise Value (0 ~ 1000)	-12	0	250	500	750	1000	1011
Percentile Value(0 ~ 1000)	-12	0	250	500	750	1000	1011

## 8.5 Accuracy

Accuracy of digital output value does not change even if input range is changed. Figure below shows the range of the accuracy with analog input range of 0 ~ 10 V and digital output type of unsigned value selected.

Accuracy of XBO-AD02A is  $\pm 1.0\%$ .

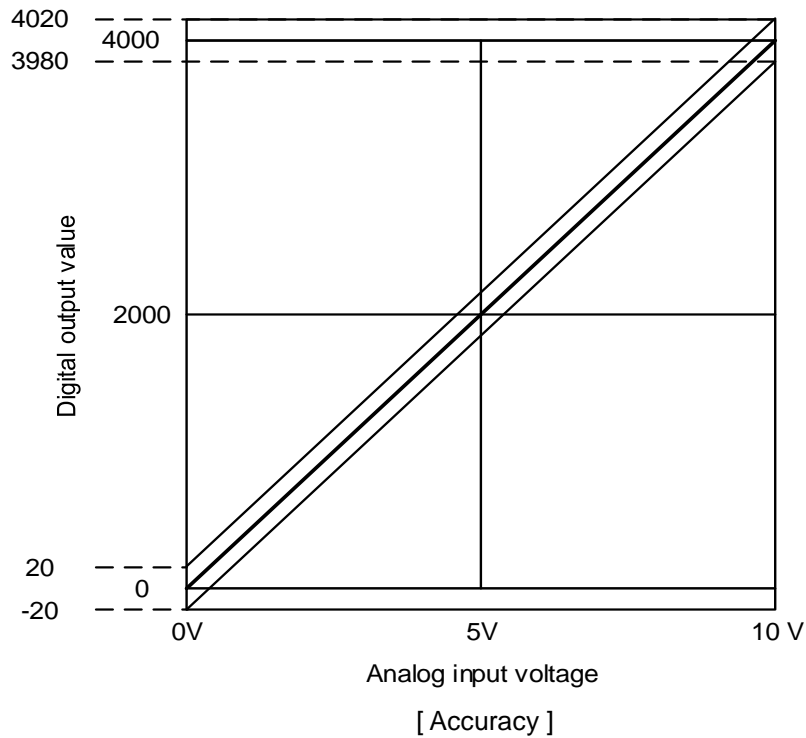

(1) Accuracy when using 5V input

$$4000 \times 1.0\% = 40$$

Therefore the range of the accuracy will become  $(2000-40) \sim (2000+40) = 1960 \sim 2040$  when using 5V input.

(2) Accuracy when using 10V input

$$4000 \times 1.0\% = 40$$

Therefore the range of the accuracy will become  $(4000-40) \sim (4000+40) = 3960 \sim 4040$  when using 10V input.

## 8.6 Functions of Analog Input Option Board

The functions of analog input option board are as follows.

Function	Description
Channel operation/stop setting	<ul style="list-style-type: none"> <li>Specify operation/stop of the channel which will perform A/D conversion.</li> <li>Specifying unused channels as Stop can shorten overall operation time.</li> </ul>
Input Voltage /current range setting	<ul style="list-style-type: none"> <li>Specify desired range of analog I/O.</li> <li>Analog input option board provides 2 ranges(4~20mA, 0~20mA) of current I/O and 1 range ( 0~10V) of voltage I/O.</li> </ul>
Output data type setting	<ul style="list-style-type: none"> <li>Specify digital I/O types.</li> <li>This module provides 4 output data types (Unsigned, Signed, Precise, and Percentile Values)</li> </ul>
A/D input conversion method	<ul style="list-style-type: none"> <li>Sampling Process               <ul style="list-style-type: none"> <li>- If A/D conversion method has not been specified, the module processes sampling.</li> </ul> </li> <li>Averaging process               <ul style="list-style-type: none"> <li>- Outputs A/D converted value averaged by count to reduce rapid change of input value caused by external noise</li> </ul> </li> </ul>

### 8.6.1 Sampling Process

In popular A/D conversion process, analog input signals are collected at constant time intervals and A/D converted. The time elapsed for the analog signals to be converted into digital signals and saved in memory device depends upon the number of channels used.

$$(\text{Process Time}) = (\text{No. of Channels Used}) \times (\text{Conversion Speed} + \text{Scan time})$$

(Ex.) Process time when using 1 of 2 I/O channels and scan time is 2ms;

$$1 \times (1 \text{ ms} + 2 \text{ ms}) = 3 \text{ ms}$$

The term 'sampling' means taking sample value among continuous analog signal values at regular intervals.



### 8.6.2 Count Averaging Function

The input values of the designated channel are accumulated for the preset cycles, and the average value of the total sum is outputted in digital data.

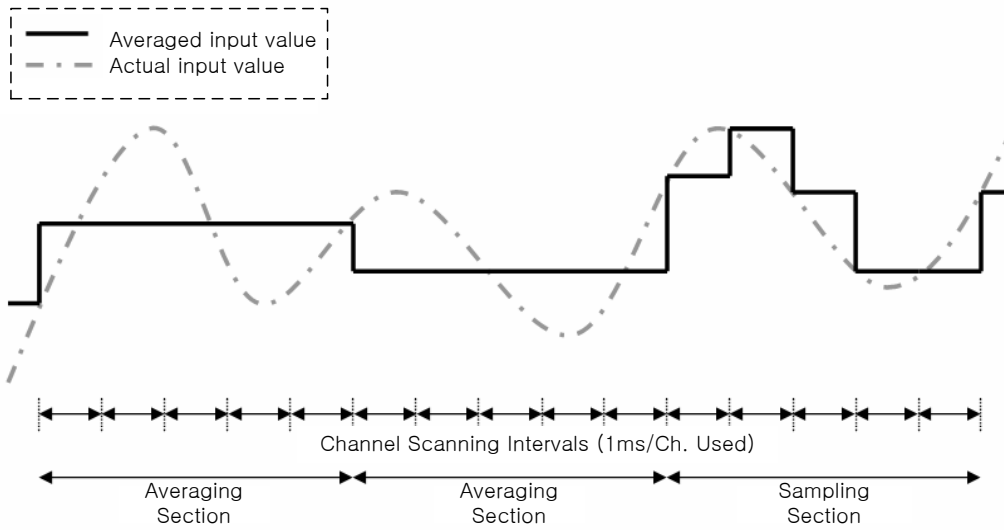

Setting Range = 2 ~ 64000 [times]

For count averaging, averaging interval is calculated with the No. of channels used.

$$\text{Averaging interval [ms]} = \text{Averaging count} \times (\text{No. of channels used} \times 1\text{ms} + \text{Scan time})$$

**Note**

(1) Averaging interval varies according to scan time

### 8.6.3 Gain Adjustment Function

You can adjust input gain of the analog input option board.

When selecting current input for analog input range, the digital output (4000) corresponding to analog input max. value (20mA) is standard gain value. When selecting voltage input, the digital output (4000) corresponding to analog input max. value (10V) is standard gain value.

- (1) You can adjust input gain at I/O parameter
- (2) Input gain setting range = - 40 ~ 40
- (3) Adjusting gain for each channel is available

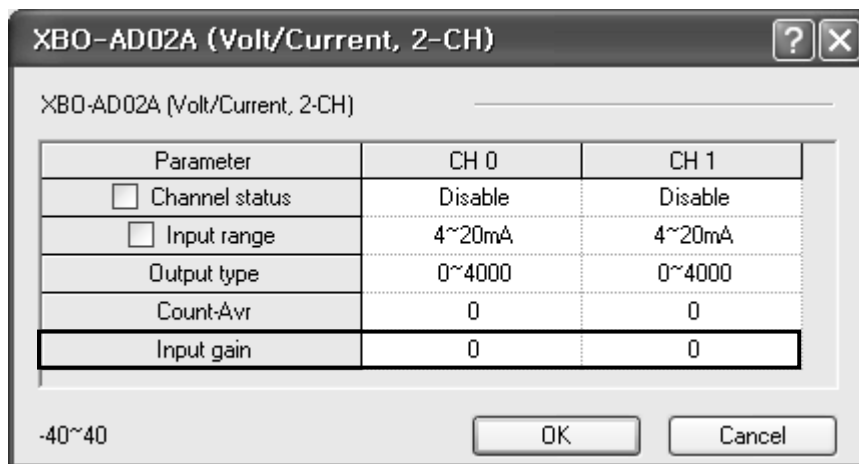

- (4) Example  
When you set "Input gain" as -5, 3996 (=4000-5) applies for gain.

#### Note

- (1) When you adjust the input gain, max. resolution changes, too.

## 8.7 Wiring

### 8.7.1 Precaution for wiring

- (1) Don't let AC power line near to A/D conversion module's external input sign line. With an enough distance kept away between, it will be free from surge or inductive noise.
- (2) Cable shall be selected in due consideration of ambient temperature and allowable current, whose size is not less than the max. cable standard of AWG22 (0.3mm<sup>2</sup>).
- (3) Don't let the cable too close to hot device and material or in direct contact with oil for long, which will cause damage or abnormal operation due to short-circuit.
- (4) Check the polarity when wiring the terminal.
- (5) Wiring with high-voltage line or power line may produce inductive hindrance causing abnormal operation or defect.
- (6) Enable only needed channels

### 8.7.2 Wiring examples

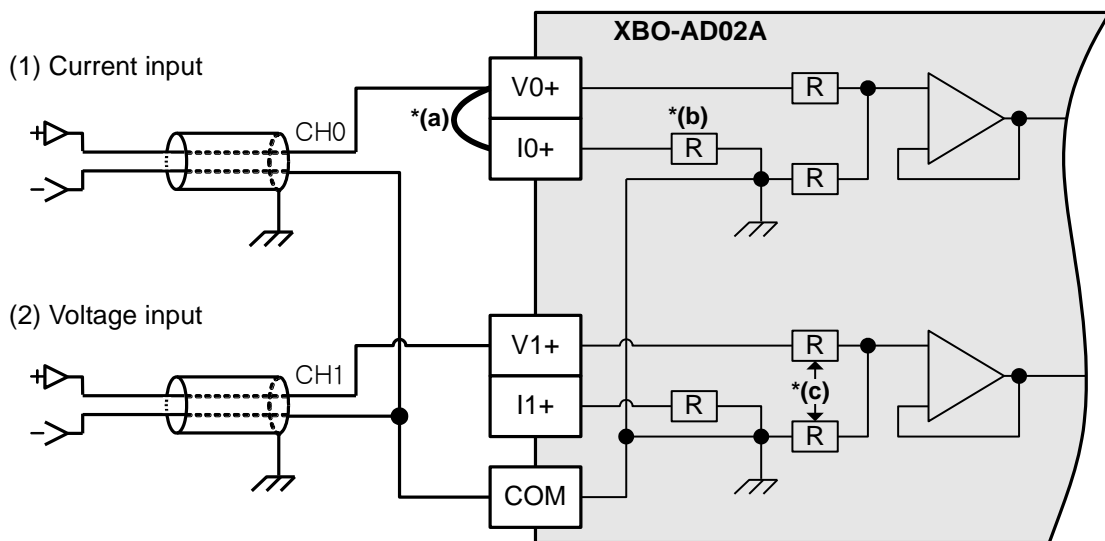

- \* (a) In case of current input, connect V+ terminal to I+ terminal
- \* (b) Input resistance of current input circuit is 250  $\Omega$  (typ.).
- \* (c) Input resistance of voltage input circuit is 1 M $\Omega$  (min.)

#### (3) Terminal block configuration

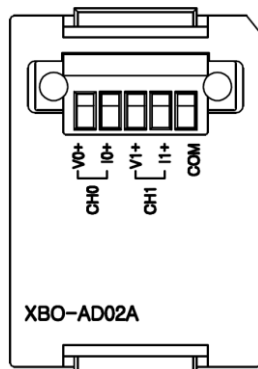

(4) Relationship between voltage input accuracy and wiring length

In voltage input, the wiring (cable) length between transmitter or sensor and option board has an effect on digital-converted values of the option board as specified below;

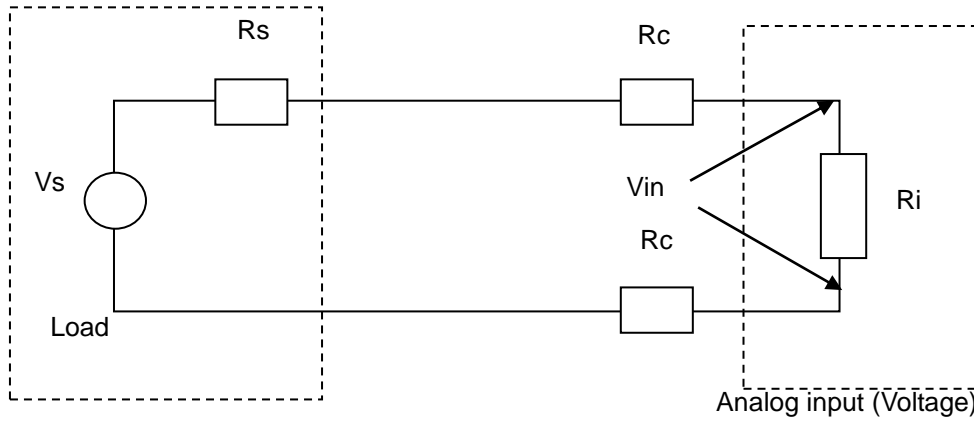

Where,

$R_c$ : Resistance value due to line resistance of cable

$R_s$ : Internal resistance value of transmitter or sensor

$R_i$ : Internal resistance value ( $1M\Omega$ ) of voltage input module

$V_{in}$ : Voltage allowed to analog input module

%  $V_i$ : Tolerance of converted value (%) due to source and cable length in voltage input

$$V_{in} = \frac{R_i \times V_s}{[R_s + (2 \times R_c) + R_i]}$$

$$\% V_i = \left(1 - \frac{V_{in}}{V_s}\right) \times 100\%$$

## 8.8 Operation Parameter Setting

Analog input option board's operation parameters can be specified through XG5000's [I/O parameters].

(1) Settings

For the user's convenience, XG5000 provides GUI (Graphical User Interface) for parameters setting of analog option board. Setting items available through [I/O parameters] on the XG5000 project window are as described below in the table.

Item	Details
[I/O parameter]	(a) Specify the following setting items necessary for the option board operation. <ol style="list-style-type: none"> <li>1) Channel Enable/Disable setting</li> <li>2) Setting ranges of input voltage/current</li> <li>3) Output data format setting</li> <li>4) Count averaging</li> <li>5) Input gain</li> </ol> (b) If downloading is complete, Parameter set by user in XG5000 is saved in Flash memory of XGB main unit.

(2) Usage of [I/O Parameter]

- (a) Create a project with XG5000. See XG5000 Program Manual for project creation.
- (b) In the Project window, double-click [I/O Parameter].

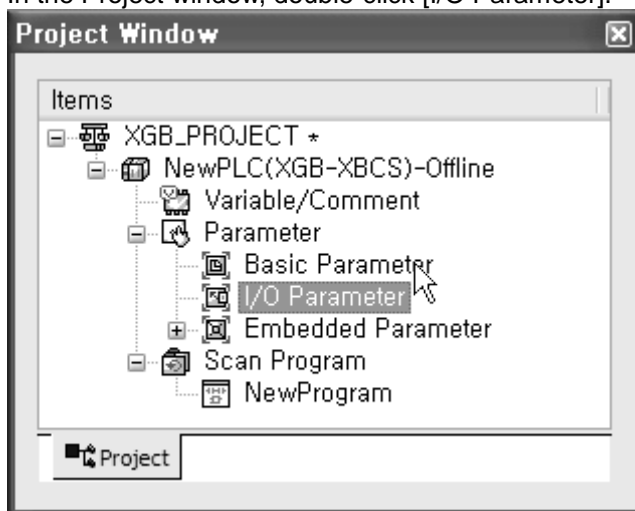

- (c) In the [I/O Parameter Setting] window, find out the slot of the base where the analog input option board is installed, and click it.

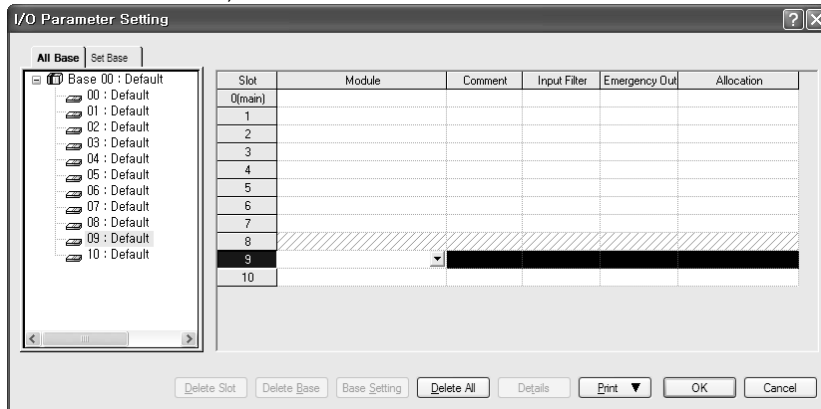

- (d) In the above window, click the arrow button to call the window where the module can be selected. Find out the module and select it.

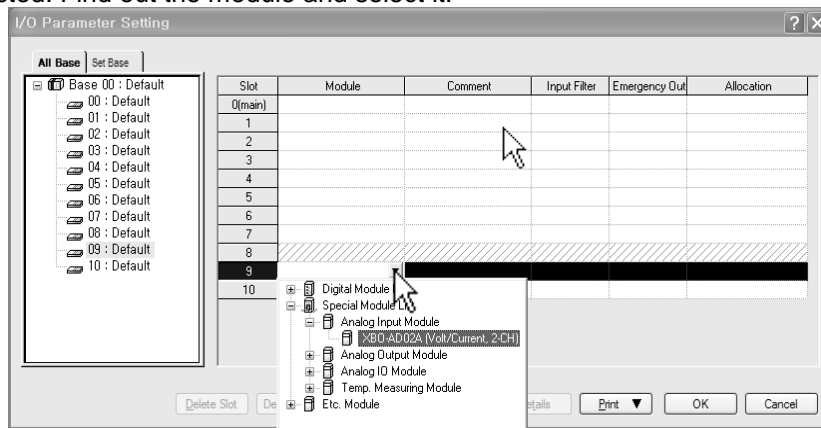

- (e) To set up parameter, double click with the respective slot being selected, or click [Detail] button.

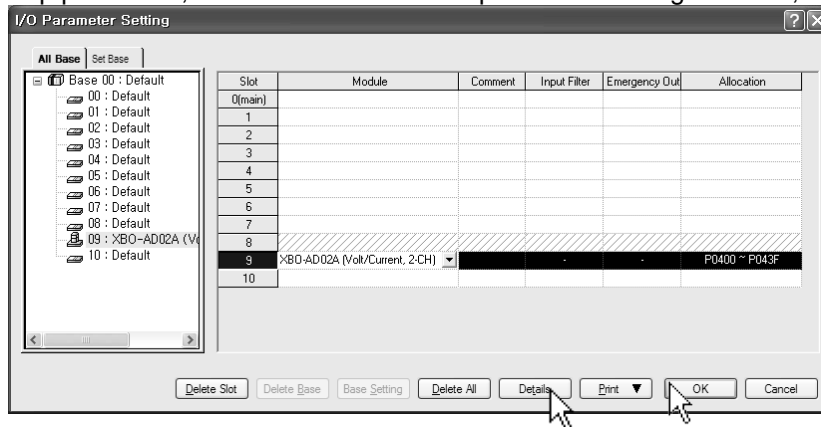

(f) The window below where parameters can be set up by channel appears. Click the item to set up. The parameters which can be set up appear by item.

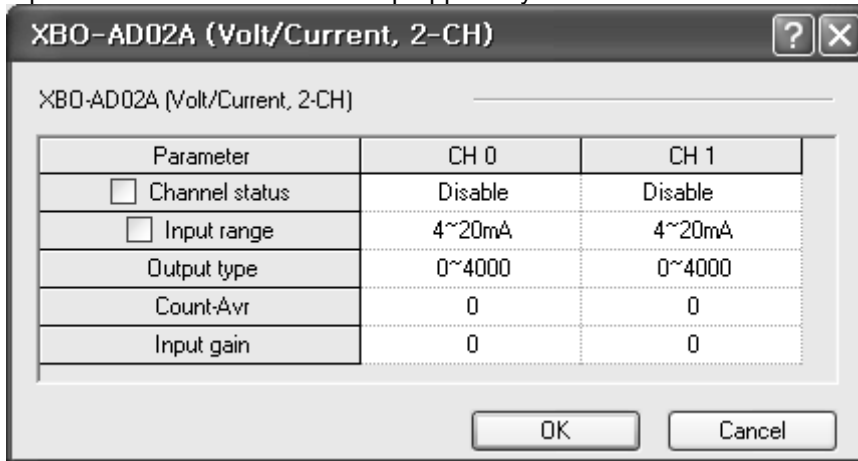

## 8.9 Special Module Monitoring Functions

The functions of the special module monitor are as follows.

(1) Start-up of [Special Module Monitor]

Select [Online] -> [Connect], and [Monitor] -> [Special Module Monitor] to start up. [Special Module Monitor] menu is enabled only in the [Online] condition.

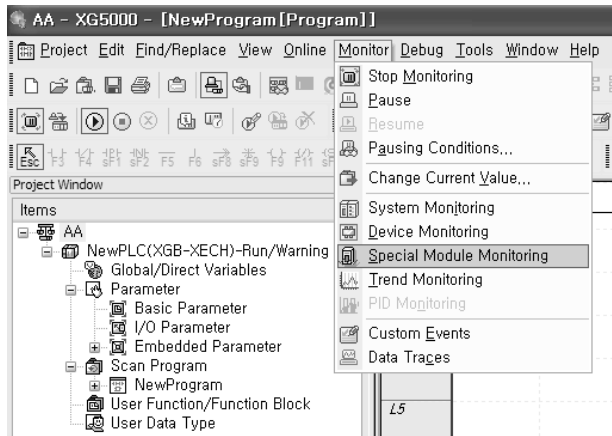

### Note

- 1) The screen may not function properly if the system resources are not sufficient. In this case, close the screen, exit other applications, and rerun XG5000.
- 2) The I/O parameters set up in [Special Module Monitor] condition are temporarily set up for testing purpose. Therefore, these I/O parameters are deleted after exit from [Special Module Monitor].
- 3) The test function of the [Special Module Monitor] enables testing analog input option board without sequence programming.

(2) Usage of [Special Module Monitor]

(a) With the XG5000 in connection (online) with the base unit of PLC, select [Monitor] -> [Special Module Monitor]. The Select Special Module window shown below will appear showing the type of the special modules and base/slot information. In the list dialog, the modules present in the PLC system are displayed.

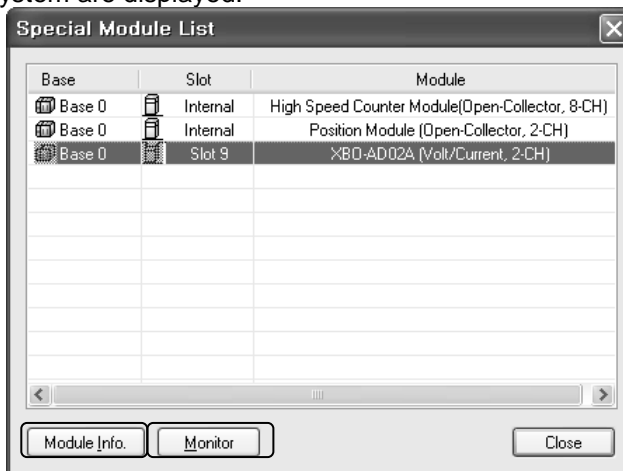



(b) In the above window, select the special module and click [Module Info.] to see the information window below.

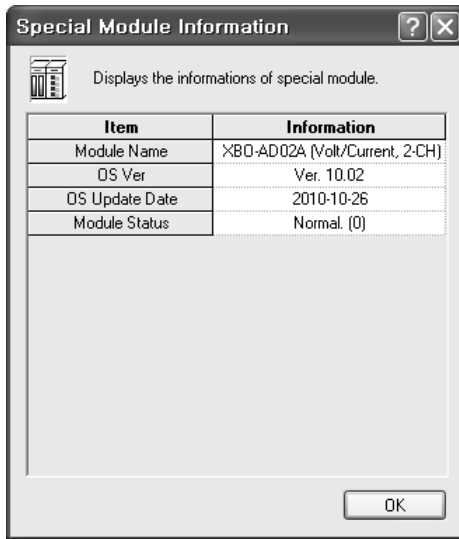

(c) Click the [Monitor] button in the “Special Module” window. The “Special Module Monitor” window will appear as shown below.

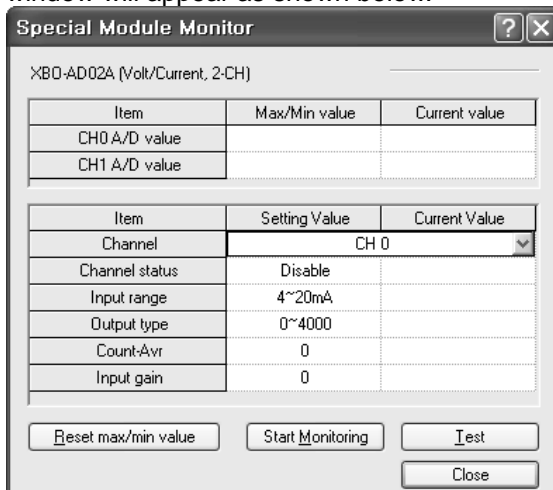

- (d) [Start Monitoring]: click [Start Monitoring] to look up the digital input data of the channel currently in operation. The screen shot below is a monitoring window when all the channels are in operation status.

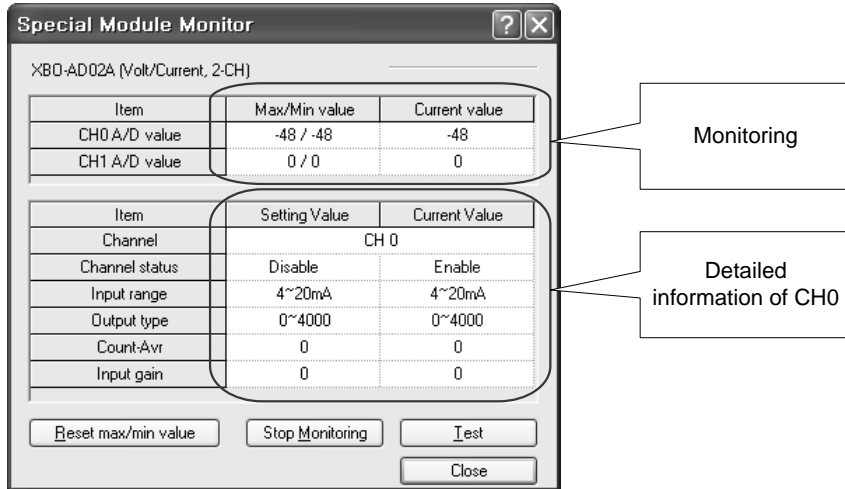

The screen executing [Start Monitoring]

- (e) [Test]: this function is used to change the current parameter settings of the analog mix module. Click the settings in the fields in the bottom screen to change the parameters. [Test] can be set up only when the operation status of the XGB base unit is STOP mode.

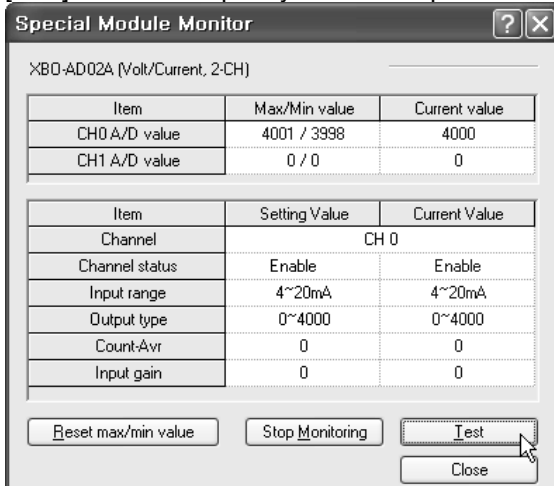

The screen executing [Test]

(f) Minimum/Maximum Value Monitoring

The minimum and maximum values of the input channels in operation can be monitored. However, the Max/Min values in the window are based on the current value. Therefore, the Max/Min values are not saved when exiting from the [Monitoring/Testing Screen].

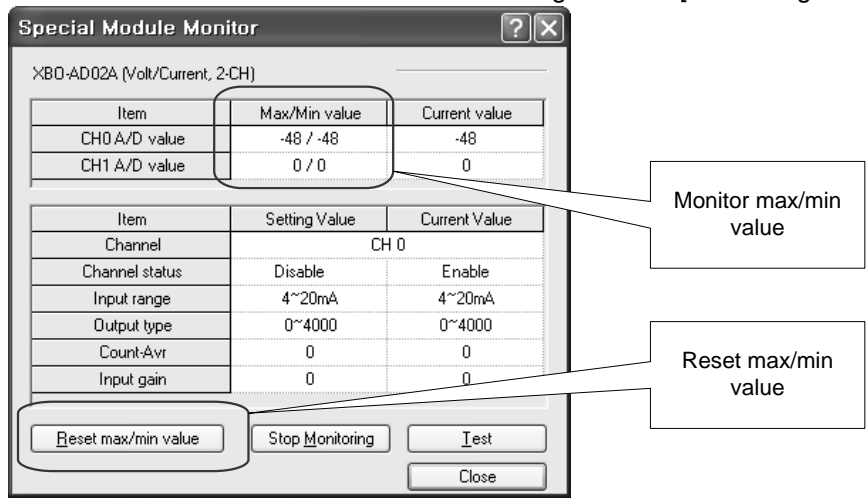

The screen executing [Max/Min Value Monitoring]

(g) Close

[Close] button is for ending/closing the monitoring/testing screen. Maximum, minimum, and current values are not saved at exit.

## 8.10 Register U devices

The variables for each module are automatically registered by referring to the information of the special modules set up in the [I/O Parameter]. User can modify variables and descriptions.

### (1) Registration Procedure

(a) In [I/O Parameter], set up special module in slot.

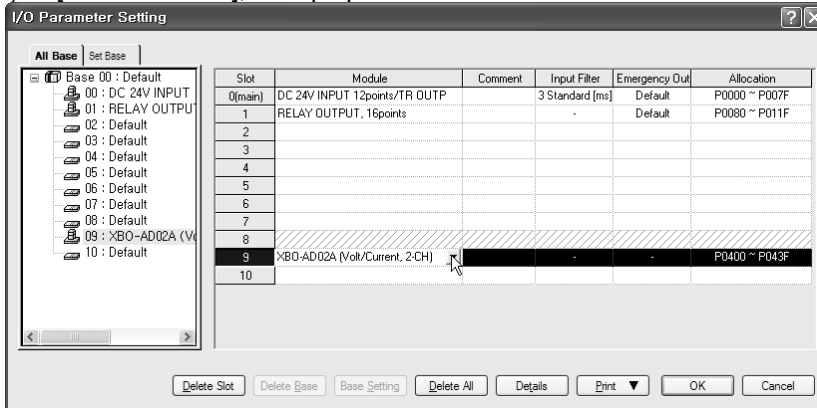

(b) Double click [Variables/Comment].

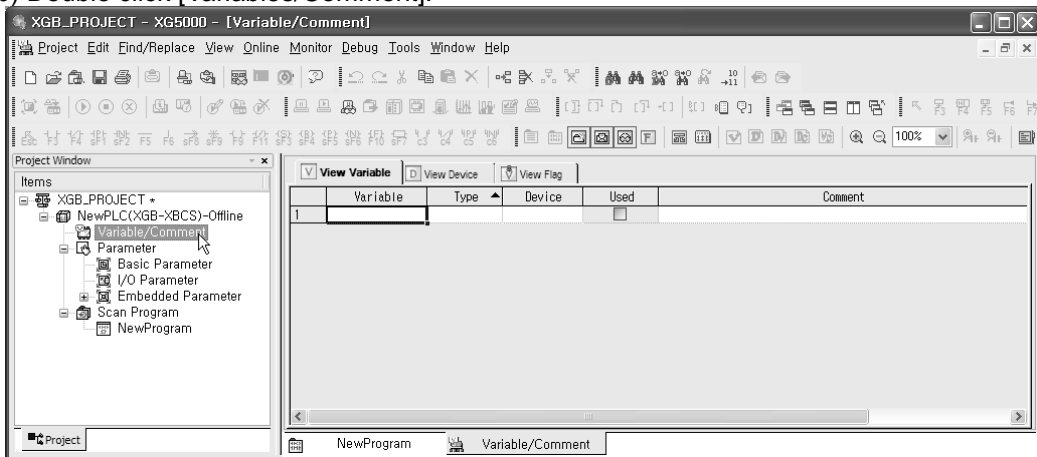

(c) In the 'Edit' menu, select 'Register U device'

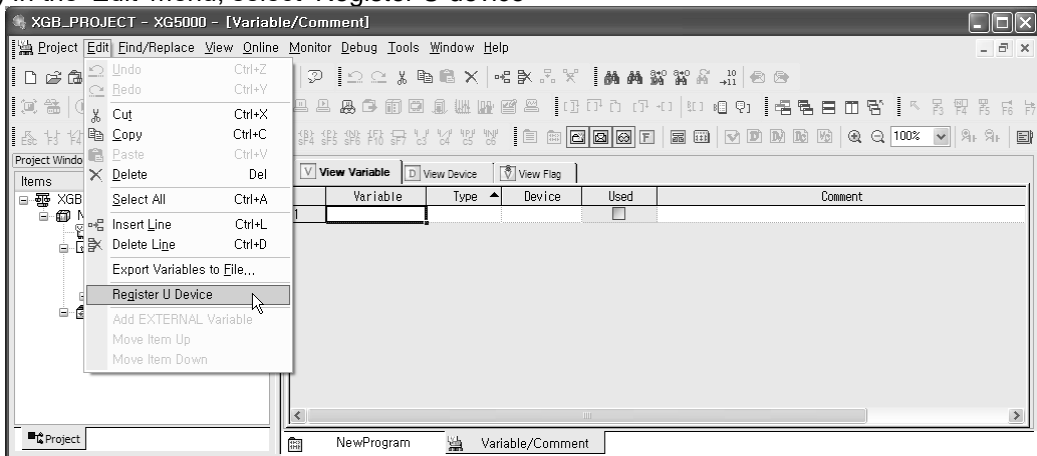

(d) Click 'Yes.'

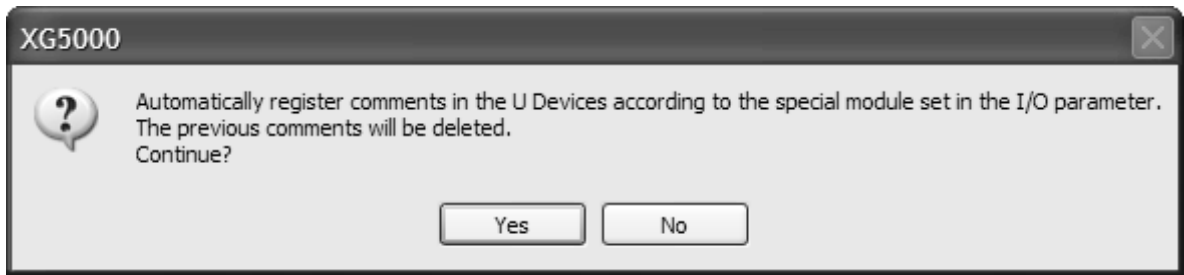

(e) Variables are registered as shown below.

	Variable	Type	Device	Used	Comment
1	_09_ERR	BIT	U09.00.0	<input type="checkbox"/>	Analog Input Option Board: Error
2	_09_RDY	BIT	U09.00.F	<input type="checkbox"/>	Analog Input Option Board: Ready
3	_09_ADD_ACT	BIT	U09.01.0	<input type="checkbox"/>	Analog Input Option Board: Input CH0 Active
4	_09_AD1_ACT	BIT	U09.01.1	<input type="checkbox"/>	Analog Input Option Board: Input CH1 Active
5	_09_ADD_IDD	BIT	U09.01.4	<input type="checkbox"/>	Analog Input Option Board: CH0 Input Disconnection Flag
6	_09_AD1_IDD	BIT	U09.01.5	<input type="checkbox"/>	Analog Input Option Board: CH1 Input Disconnection Flag
7	_09_ADD_ERR	BIT	U09.01.8	<input type="checkbox"/>	Analog Input Option Board: Input CH0 Error
8	_09_AD1_ERR	BIT	U09.01.9	<input type="checkbox"/>	Analog Input Option Board: Input CH1 Error
9	_09_ADD_DATA	WORD	U09.04	<input type="checkbox"/>	Analog Input Option Board: Input CH0 Data
10	_09_AD1_DATA	WORD	U09.05	<input type="checkbox"/>	Analog Input Option Board: Input CH1 Data

(2) Saving Variables

- (a) The contents in the 'View Variables' tab can be saved in a text file.
- (b) In the 'Edit' menu, select 'Save as Text File.'
- (c) The contents in the 'View Variables' tab are saved in a text file.

(3) Viewing Variables in Program

The figures below present examples of use in XGB compact “E” and “S” types

(a) Below is an exemplary program for XG5000.

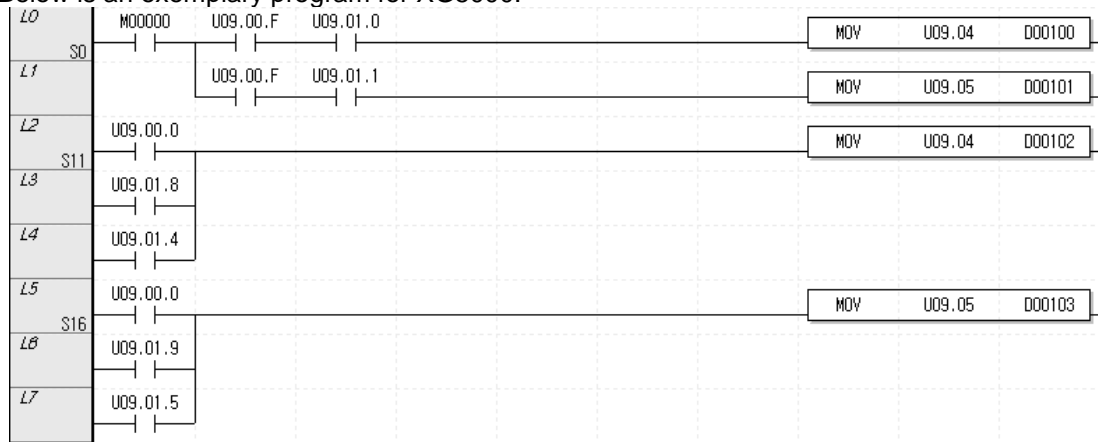

(b) In the 'View' menu, click 'View Variables.' The devices are changed into variables.

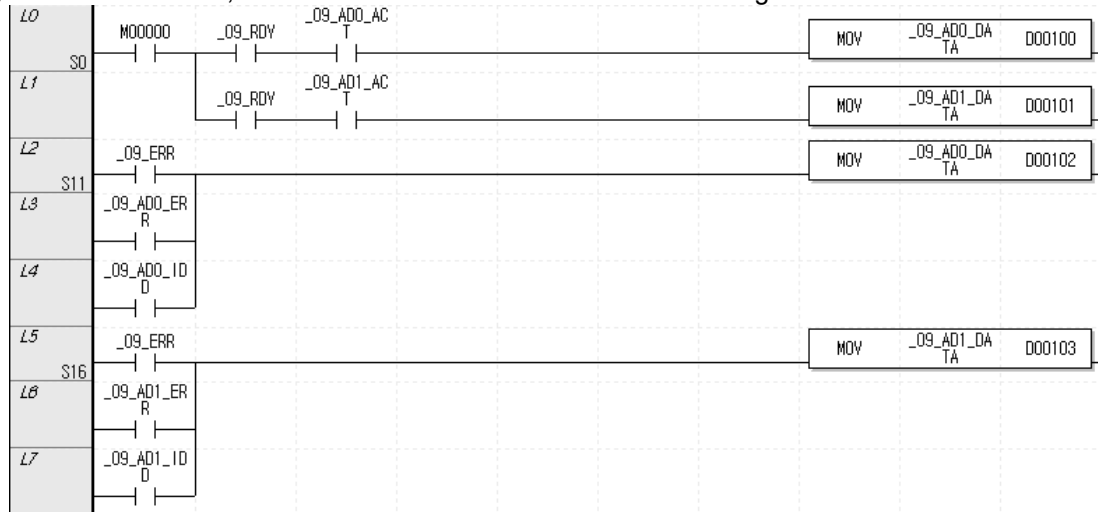

(c) In the 'View' menu, click 'View Device/Variables' to look up the devices and variables at the same time.

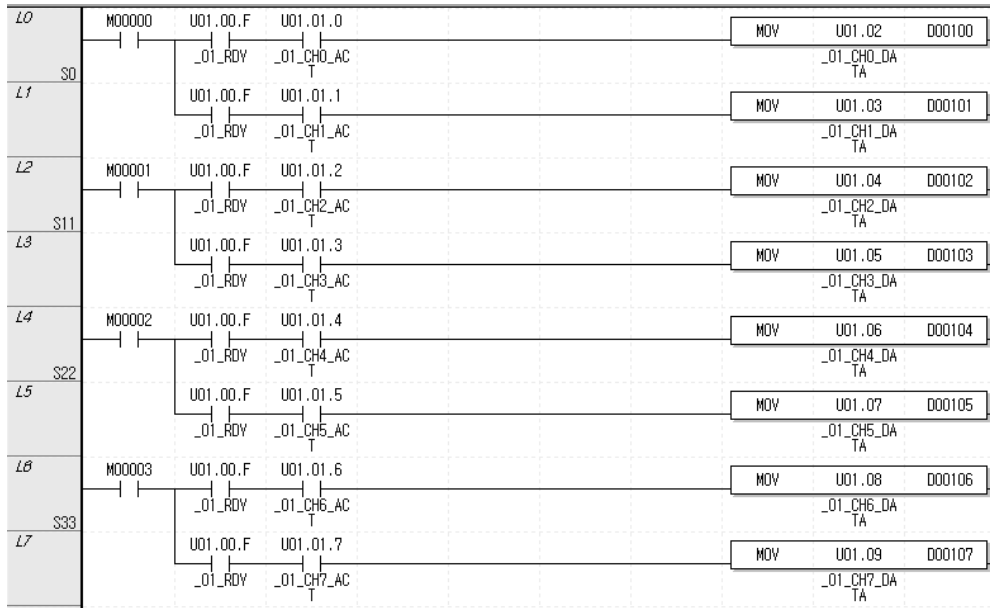

(d) In the 'View' menu, click 'View Device/Comment' to look up the devices and descriptions at the same time.

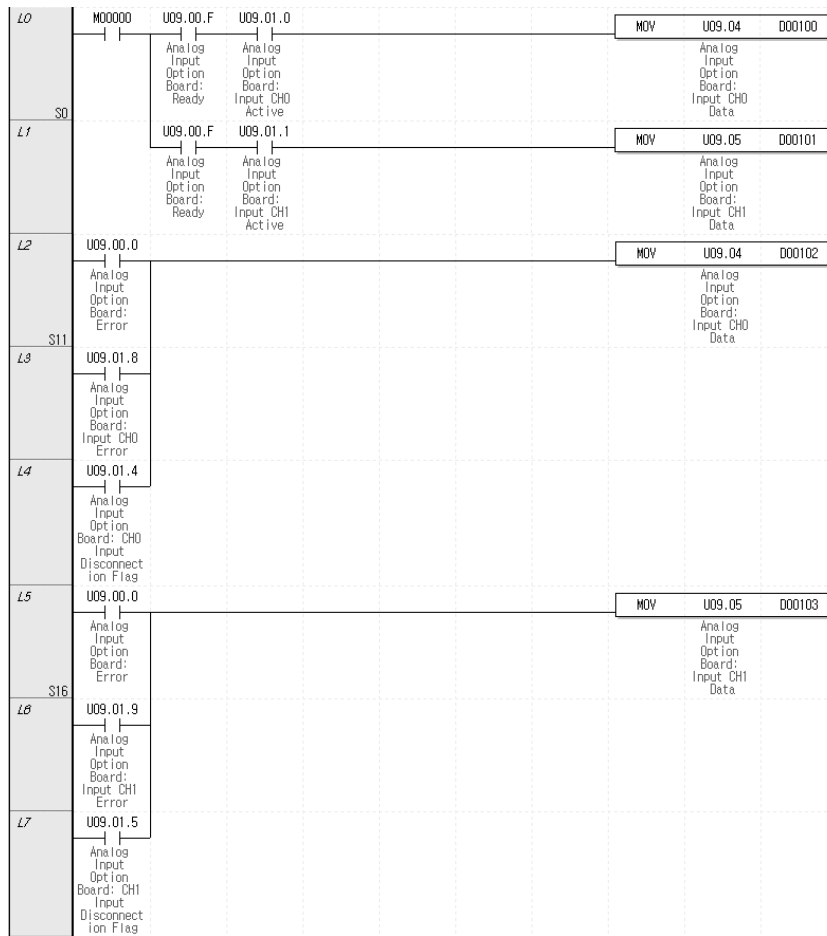

(e) In the 'View' menu, click 'View Variable/Comment' to look up the devices and descriptions at the same time.

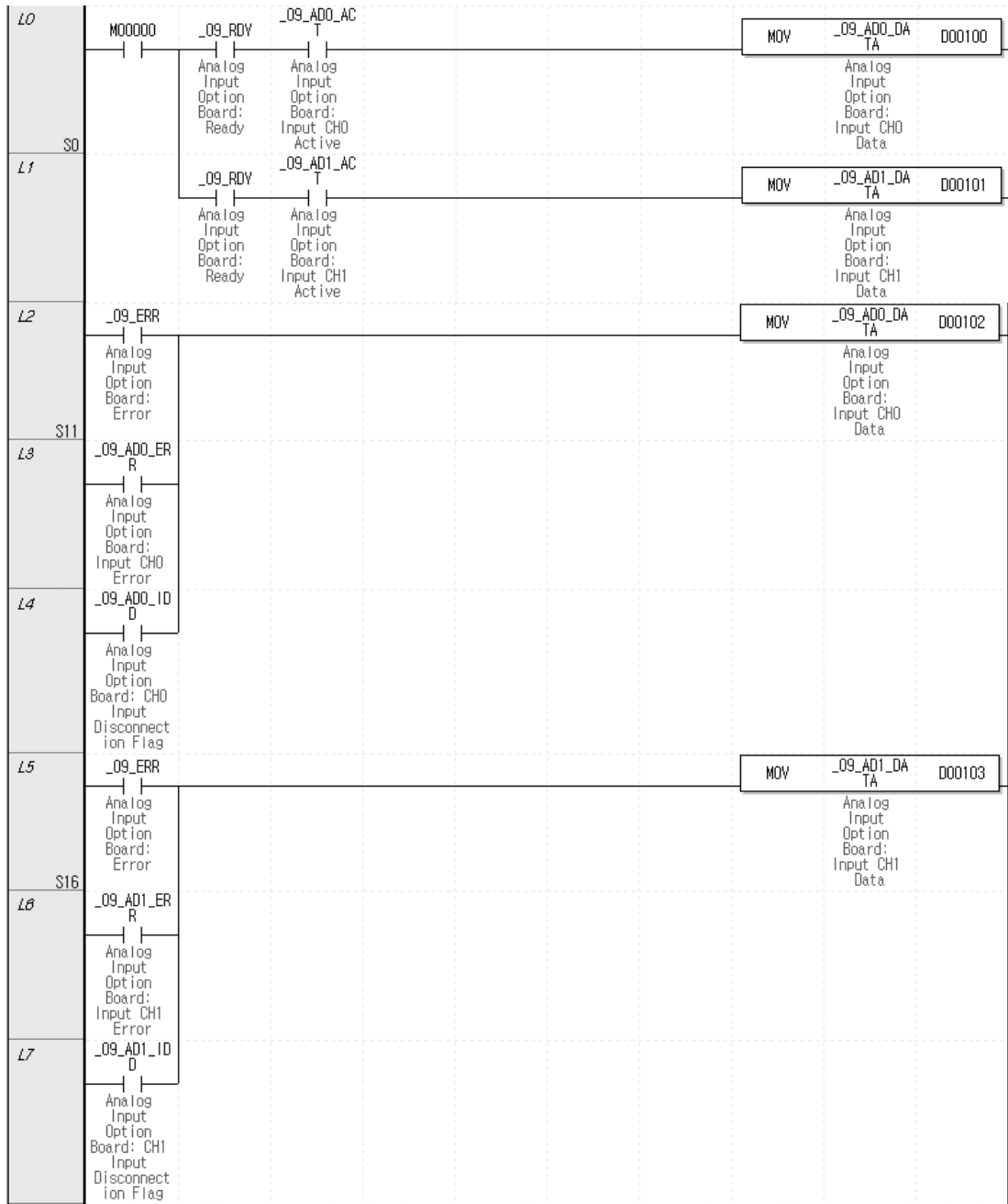



## Chapter 8 Analog Input Option(XBO-AD02A)

(f) For IEC type also, as shown in Fig. (a) ~ (e), you can look up variables with diversified options in the 'View' menu. The figure below is the case of an IEC type with which the 'View Device/Variables' option.

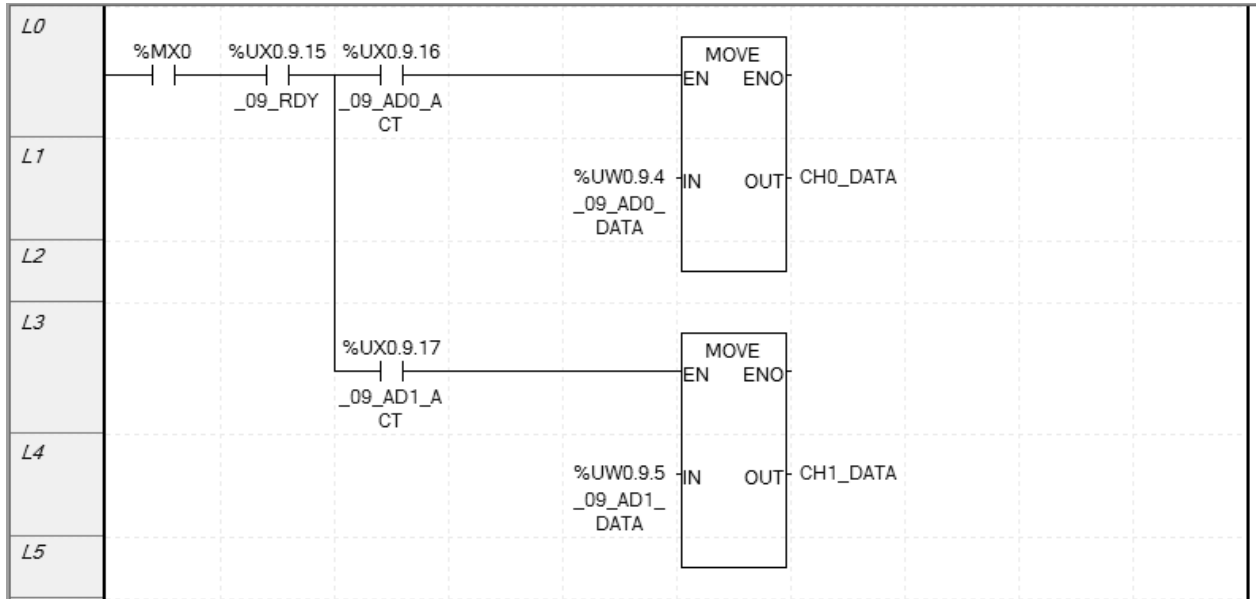

## 8.11 Configuration and Function of Internal Memory

An analog input option board has internal memory for data communication with XGB base unit.

### 8.11.1 Analog Data I/O Area

The table below presents the analog data I/O area.

Variable	Type	Device assignment		Description	R/W	Signal direction
		XBC	IEC			
_0y_ERR	BIT	U0y.00.0	%UX0.y.0	Module Error	R	Option → CPU
_0y_RDY	BIT	U0y.00.F	%UX0.y.15	Module Ready		
_0y_AD0_ACT	BIT	U0y.01.0	%UX0.y.16	CH0 Active	R	Option → CPU
_0y_AD1_ACT	BIT	U0y.01.1	%UX0.y.17	CH1 Active		
_0y_AD0_IDD	BIT	U0y.01.4	%UX0.y.20	CH0 Disconnection flag	R	Option → CPU
_0y_AD1_IDD	BIT	U0y.01.5	%UX0.y.21	CH1 Disconnection flag		
_0y_AD0_ERR	BIT	U0y.01.8	%UX0.y.24	CH0 error	R	Option → CPU
_0y_AD1_ERR	BIT	U0y.01.9	%UX0.y.25	CH1 error		
_0y_AD0_DATA	WORD	U0y.04	%UW0.y.4	CH0 Output	R	Option → CPU
_0y_AD1_DATA	WORD	U0y.05	%UW0.y.5	CH1 Output	R	Option → CPU

- In the device allocation, the small letter 'y' is the No. of the slot where the module is installed.
- For example, to read the 'CH0 Input A/D Value' of the analog module installed in the slot 9, write in U09.05. (%UW0.9.4 for IEC types)

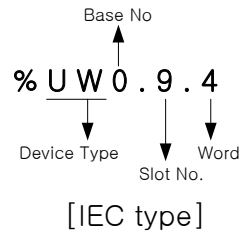
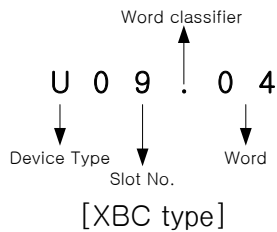

- (1) Module Ready/Error Flag ( ) is for IEC types, y: slot No.)
  - (a) U0y.00.F(%UX0.y.15): at power on or reset of PLC CPU, turns on when the analog I/O conversion is ready and analog conversion is performed.
  - (b) U0y.00.0(%UX0.y.0): the flag indicating the error status of analog input option board module.

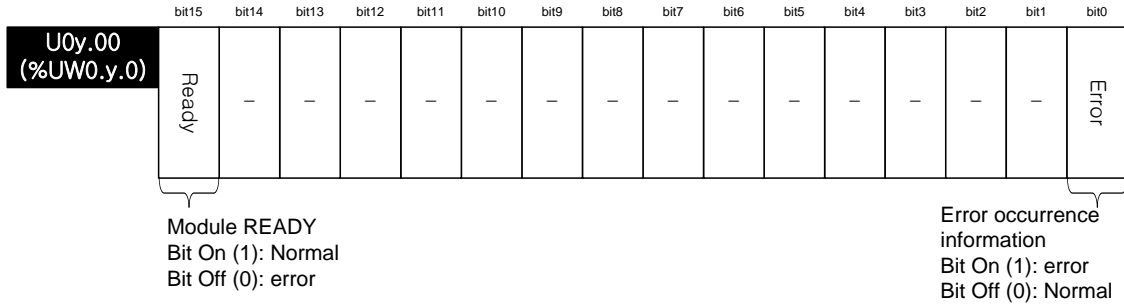

- (2) Operation channel information/ channel error information flag ( ) is for IEC types, y: slot No.)  
This is the area for storing the operation information and channel error information by channel.

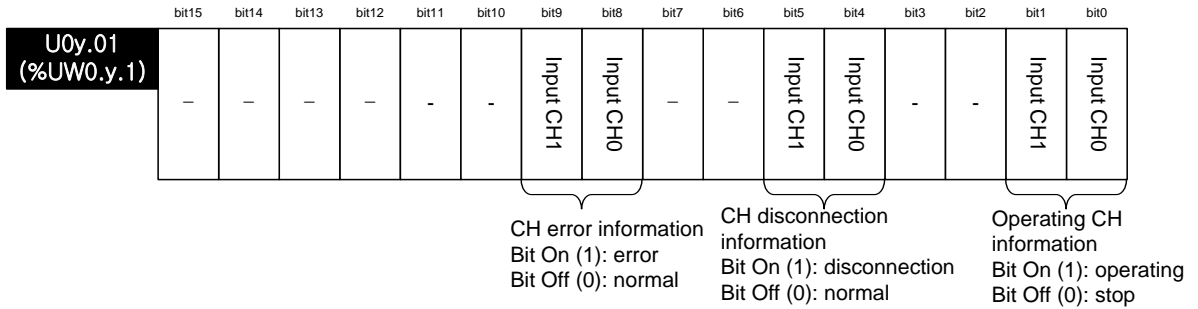

- (3) Digital Output Values ( ) is for IEC types, y: slot No.)
  - (a) A/D converted digital values are outputted to buffer memory address U0y.04 ~ U0y.05 by channel-basis.
  - (b) Digital output values are saved in 16-bit binary figures.

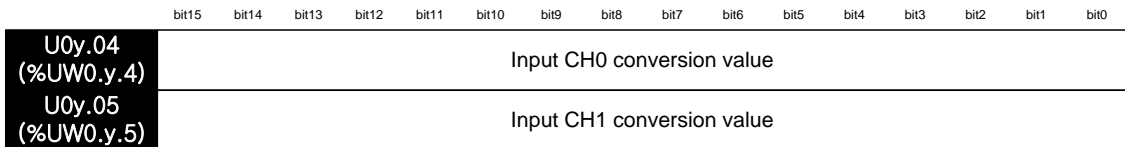

### 8.11.2 Operation Parameter Setting Area

The operation parameter setting area of the analog mix module is as follows.

Memory Add.	Description	Setting	R/W	Command
0	Enable channel	Bit Off (0): disable, Bit ON (1): enable	R/W	PUT/GET
1	Input range setting	Input range setting (4 bit per channels) 0: 4 ~ 20 mA 1: 0 ~ 20 mA 2: 0 ~ 10 V	R/W	
2	Output data type setting	Output data type setting (4 bit per channels) 0: 0 ~ 4000 1: -2000 ~ 2000 2: Precise value 3: 0 ~ 1000 - In case of precise value 4 ~ 20 mA: 400 ~ 2000 0 ~ 20 mA: 0 ~ 2000 0 ~ 10 V: 0 ~ 1000	R/W	
3	Input channel 0 count average value setting	0 or 2 ~ 64000 [times]	R/W	
4	Input channel 1 count averaging value setting		R/W	
9	Input channel 0 gain weighting	-40~40	R/W	
10	Input channel 1 gain weighting		R/W	
13	Setup error information	10#: input ch range setting error 20#: input ch data type setting error 30#: input ch average value setting error 40#: input ch gain weighting setting error (#: channel number)	R	GET

- (1) Operating Channel Setting (address 0)
  - (a) You can set "Enable/Disable" of analog input option board per each channel
  - (b) Disable the unused channels to reduce the conversion period.
  - (c) Default value is "Disable" for all channels
  - (d) When using PUT instruction, address is as follows.



Enable CH  
 Bit On (1): enable  
 Bit Off (0): disable

- (e) The values set in bit 2~15 are ignored.
- (f) This area is same as setting in "Channel status" of I/O parameter

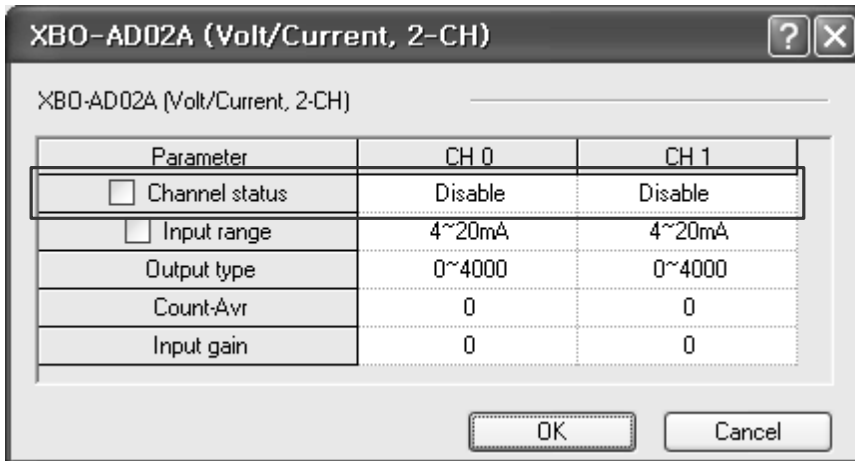

(2) Input range setting area (address 1)

(a) Set the type of input range with the following code

Bit (HEX)	Input range
0000 (0)	4 ~ 20 mA
0001 (1)	0 ~ 20 mA
0010 (2)	0 ~ 10 V

(b) If you set more than 3, 0 (4~20mA) will be set forcibly

But, U0X.01.8~ U0X.01.9 (Setup error flag) will be ON.

(c) When using PUT instruction, address is as follows.

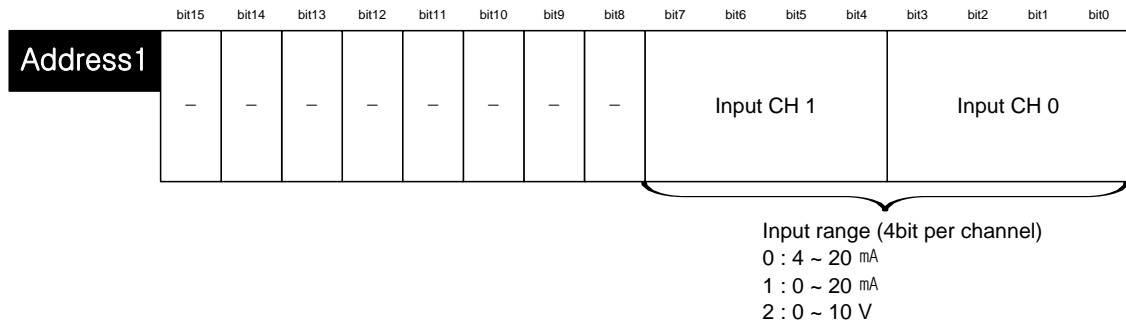

(d) The values set in bit 8~15 are ignored.

(e) This area is same as setting in "Input range" of I/O parameter

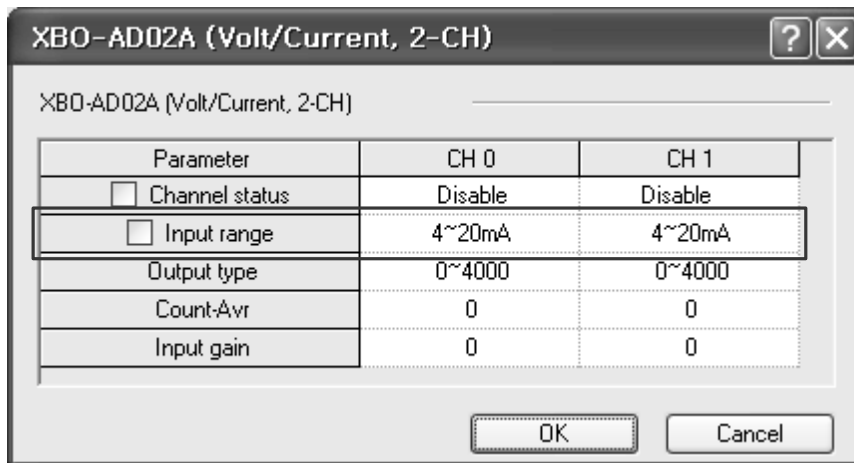

(3) Output data type setting area (address 2)

(a) Set the type of output data type with the following code

Bit (HEX)	Output data type
0000 (0)	0~4000
0001 (1)	-2000~2000
0010 (2)	Precise value
0011 (3)	0~1000

In case of precise value, output data type is designated as the following value according to each input range type

Input range	Precise value
4 ~ 20 mA	400 ~ 2000
0 ~ 20 mA	0 ~ 2000
0 ~ 10 V	0 ~ 1000

(b) If you set more than 4, 0 (0~4000) will be set forcibly.

But, U0X.01.8~ U0X.01.9 (Setup error flag) will be ON.

(c) When using PUT instruction, address is as follows



Output type (4bit per channel)

- 0 : 0 ~ 4000
- 1 : -2000 ~ 2000
- 2 : precise value
- 3 : 0 ~ 1000

- In case of precise value

- 4 ~ 20 mA: 400 ~ 2000
- 0 ~ 20 mA: 0 ~ 2000
- 0 ~ 10 V: 0 ~ 1000

(d) The values set in bit 8~15 are ignored.

(e) This area is same as setting in "Output type" of I/O parameter

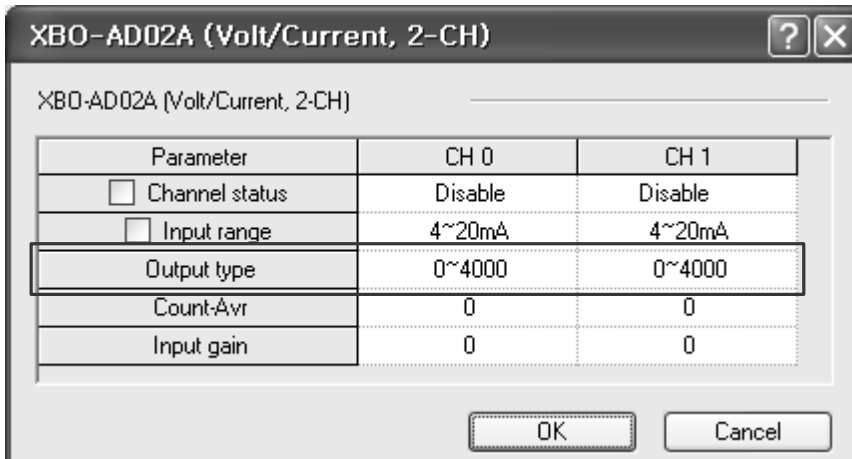

- (4) Count average value setting area (address 3~4)
  - (a) Set count average value with 0 or value of 2~6400
  - (b) If you set the count average value as 0, corresponding channel will not perform averaging process and output sampled analog input value
  - (c) If you set 1 or more than 64001, 0 (Disable averaging) will be set forcibly.  
But, U0X.01.8~ U0X.01.9 (Setup error flag) will be ON.
  - (d) When using PUT instruction, address is as follows

Address3	bit15 bit14 bit13 bit12 bit11 bit10 bit9 bit8 bit7 bit6 bit5 bit4 bit3 bit2 bit1 bit0	Input CH0 count average value (0 or 2 ~ 64000 [times])
Address4		Input CH1 count average value (0 or 2 ~ 64000 [times])

(e) This area is same as setting in "Count-Avr" of I/O parameter

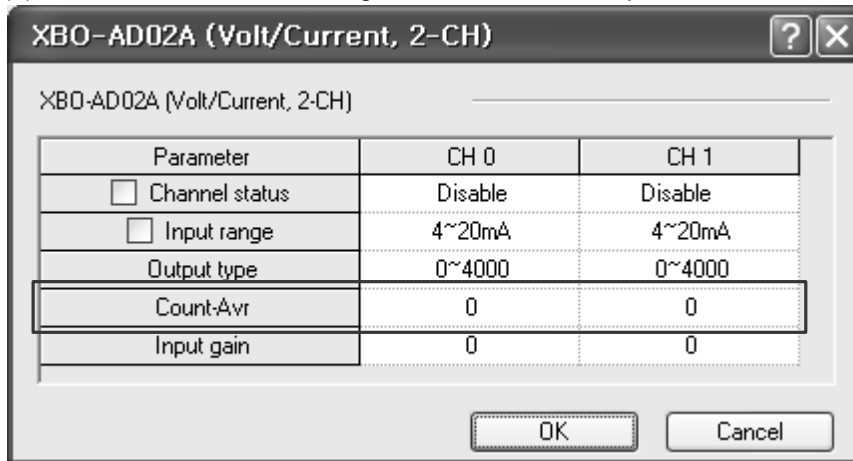



- (5) Input gain weighting setting area (address 9~10)
  - (a) Set input gain weighting with value of -40~40
  - (b) If you set this as 0 (default value), 4000 will apply for gain value
  - (c) For example, if you set this as -10, 4010 (=4000-(-10)) will apply for gain value
  - (d) When using PUT instruction, address is as follows

Address9	Input CH0 gain (-40 ~ 40)
Address10	Input CH1 gain (-40 ~ 40)

(e) This area is same as setting in "Input gain" of I/O parameter

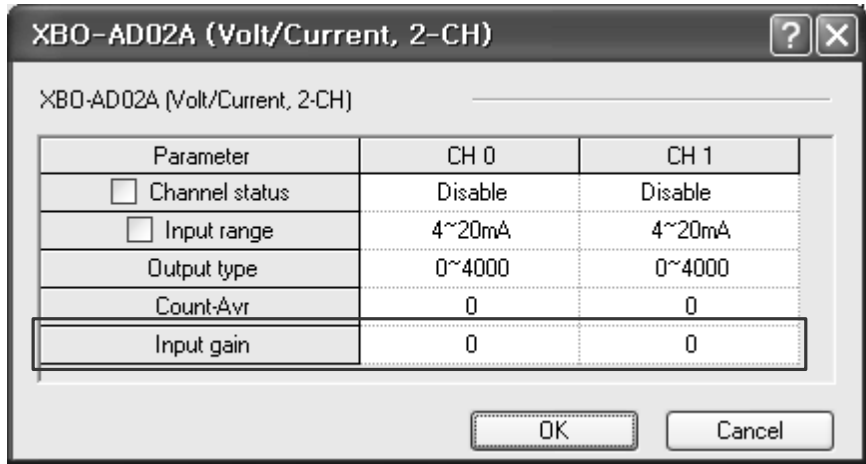

- (6) Setup error information output area (address 13)
  - (a) Saves error code detected when setting (setting by program)
  - (b) Setting error is canceled when value is reset to make it in the valid range
  - (c) When U0X.01.8~ U0X.01.9 (setting error flat) is on, check that area and fix the corresponding setting to cancel the error
  - (d) When using GET instruction, address is as follows

Address13	Setting error information
-----------	---------------------------

Type	Error code	Description	Priority	Remark
Setting error	10#	Input CH range setting error	1	#: CH number Input CH 0,1
	20#	Input CH data type setting error	2	
	30#	Input CH count average value setting error	3	
	40#	Input CH gain weighting setting error	4	

(e) When more than two errors occur simultaneously, it saves error code having higher priority.

## 8.12 Example Program

- (1) This sample program sets up operating parameters of analog input option board.
- (2) Initial settings are saved in the internal memory of the XGB main unit by one input.
- (3) The sample program below controls the I/O data of the analog input option board at option slot #0 (I/O slot #9) and check open wire.

### 8.12.1 Example of [I/O Parameter] Usage

(1) I/O Parameter Setting Window

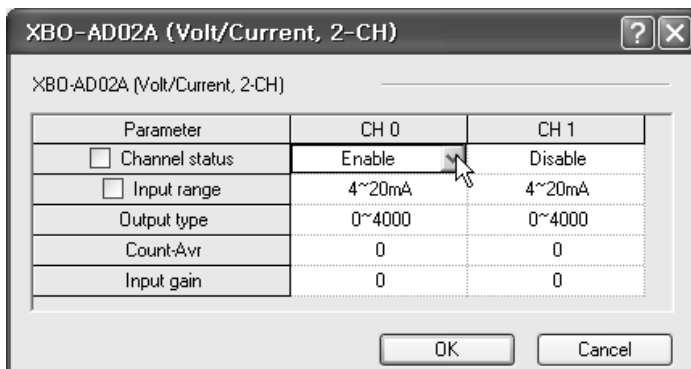
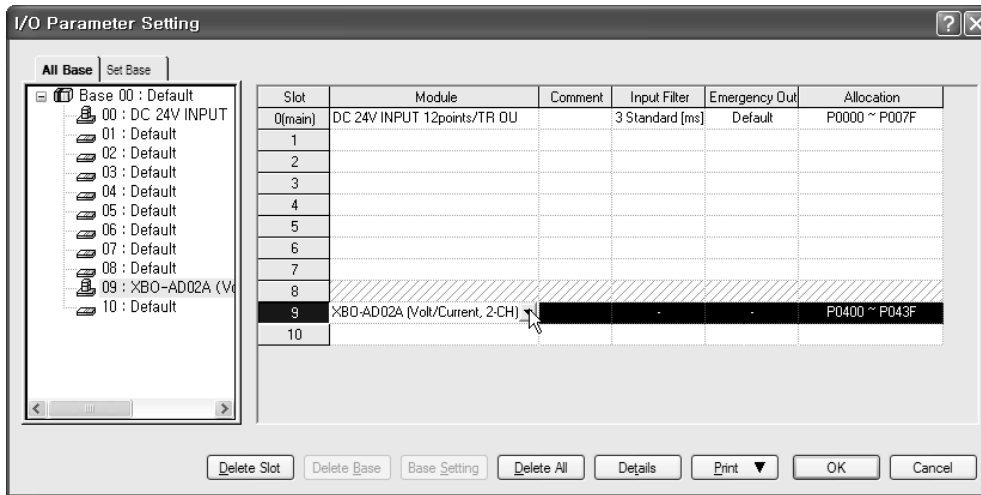

(a) Input Channel 0 is set to operating channel and input range is set to 4~20mA.

(2) Sample Program (XBC Type)

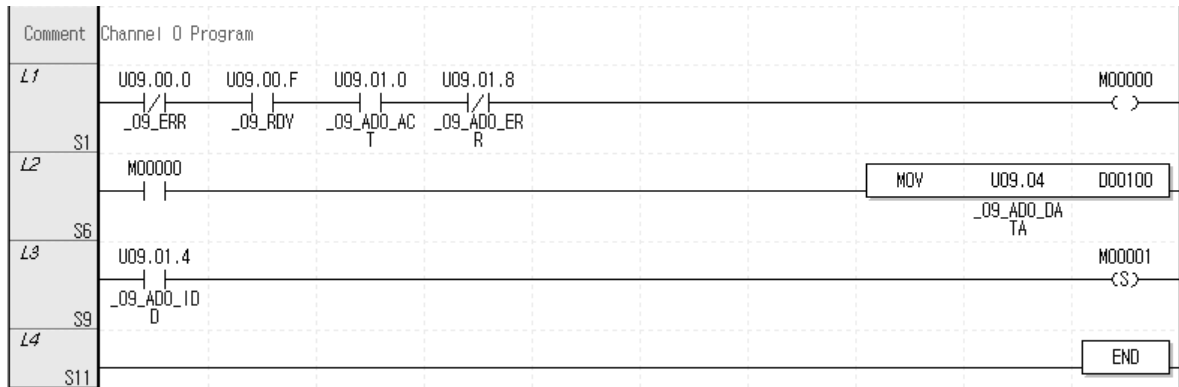

- (a) When the option board is in normal operation, M0000 is turned On.  
 U09.00.0 (Module Error) = Off  
 U09.00.F (Module Ready) = On  
 U09.01.0 (Input Channel 0 in-operation) = On  
 U09.01.8 (Input Channel 0 Error) = Off
- (b) When M0000 is ON, Input Channel 0 Converted Value(U09.04) is moved to D00100.
- (c) If open-wire error occurs in channel 0, U09.01.4 (channel 0 open-wire) is ON, and M0001 bit is set.

(3) Sample Program (IEC Type)

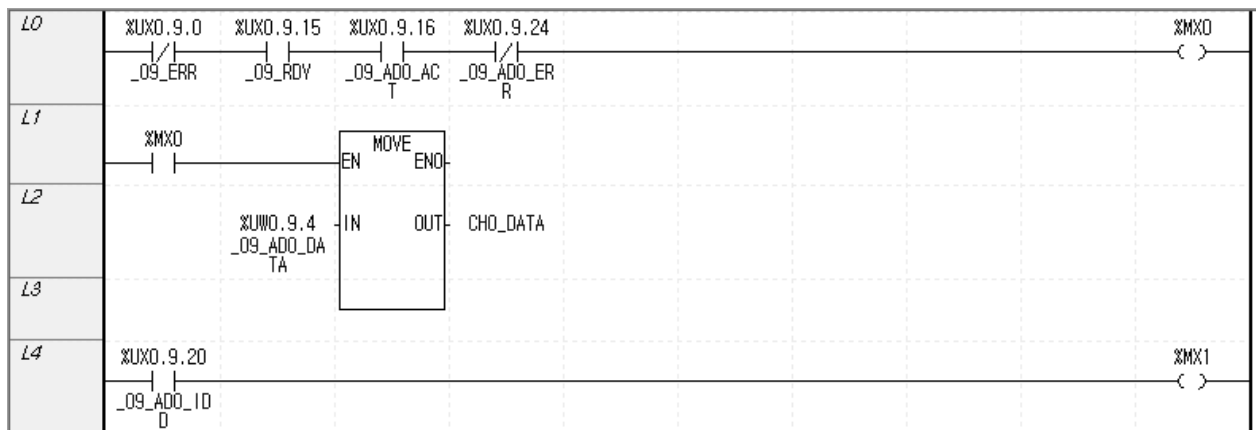

- (a) When the option board is in normal operation, %MX0 is turned On.  
 %UX0.9.0 (Module Error) = Off  
 %UX0.9.15 (Module Ready) = On  
 %UX0.9.16 (Input Channel 0 in-operation) = On  
 %UX0.9.24 (Input Channel 0 Error) = Off
- (b) When M0000 is ON, Input Channel 0 Converted Value(%UW0.9.4) is moved to "CHO\_DATA".
- (c) If open-wire error occurs in channel 0, %UX0.9.20 (channel 0 open-wire) is ON, and %M1 bit is set.

## 8.13 Troubleshooting

This section describes methods for identifying the troubles which may occur during the operation of analog input option board, and their solutions.

### 8.13.1 Troubleshooting

(1) Analog input value is abnormal.

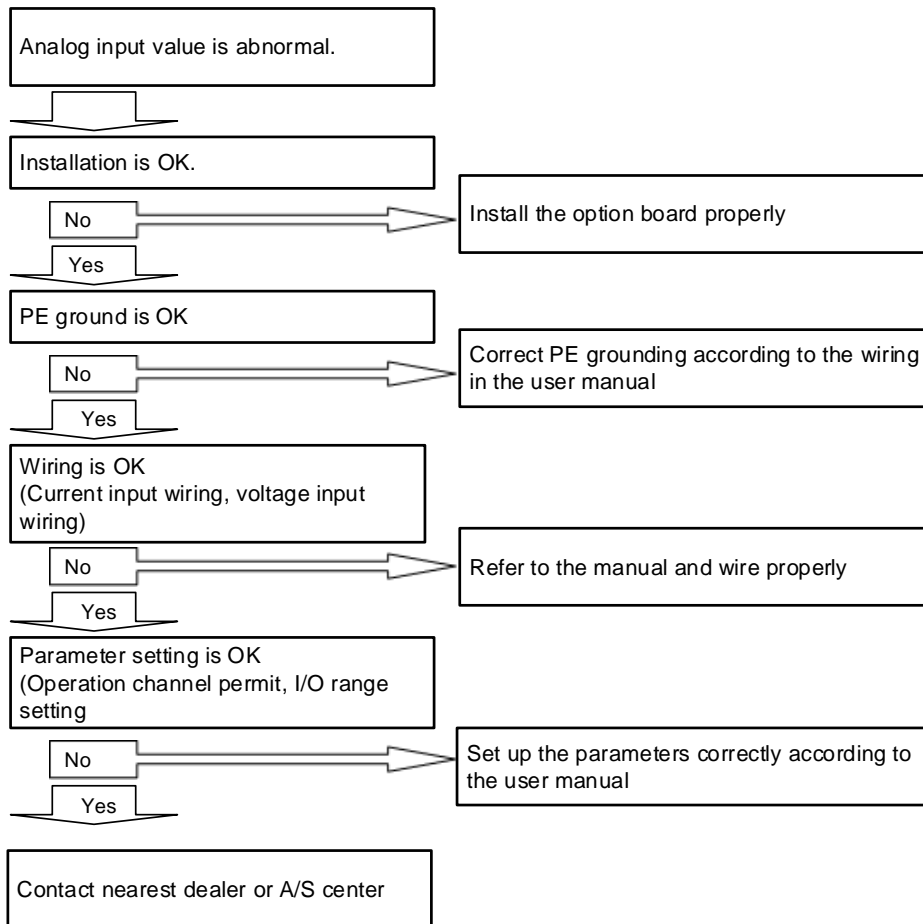

## Chapter 9 Analog Output Option Board

### 9.1 Setting Sequence before Operation

Before using the analog output option board, follow steps below.

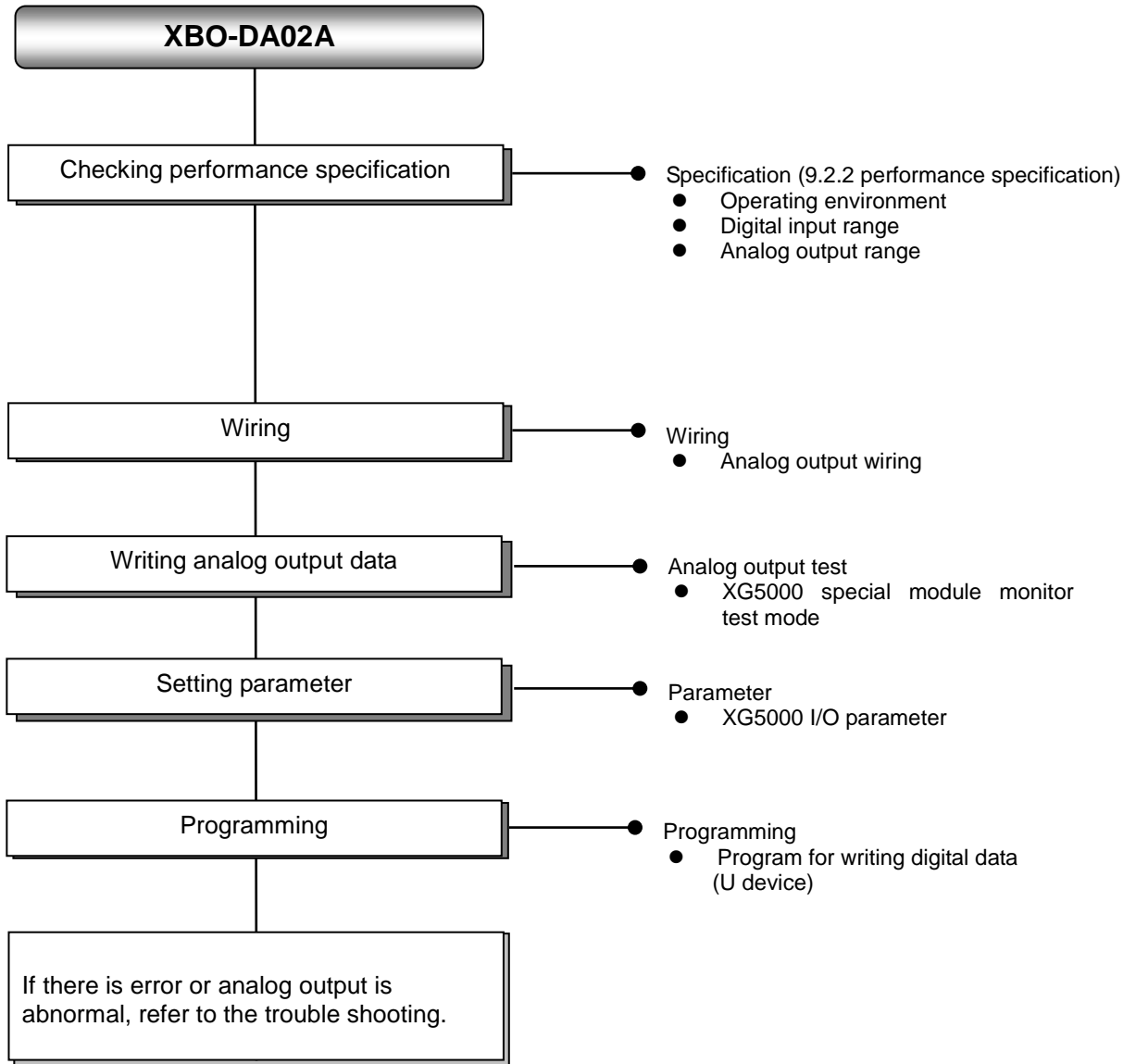

## 9.2 Specification

### 9.2.1 General specifications

Here describes general specification of analog output option board.

No.	Item	Specifications	Related specifications			
1	Ambient temperature	0°C ~ +55°C	-			
2	Storage temperature	-25°C ~ +70°C	-			
3	Ambient humidity	5 ~ 95%RH (Non-condensing)	-			
4	Storage humidity	5 ~ 95%RH (Non-condensing)	-			
5	Vibration resistance	Occasional vibration			-	IEC61131-2
		Frequency	Acceleration	Amplitude	How many times	
		5 ≤ f < 8.4 Hz	-	3.5 mm	10 times each directions (X, Y and Z)	
		8.4 ≤ f ≤ 150 Hz	9.8 m/s <sup>2</sup> (1G)	-		
		For continuous vibration				
		Frequency	Acceleration	Amplitude		
		5 ≤ f < 8.4 Hz	-	1.75 mm		
8.4 ≤ f ≤ 150 Hz	4.9 m/s <sup>2</sup> (0.5G)	-				
6	Shock resistance	<ul style="list-style-type: none"> <li>Peak acceleration: 147 m/s<sup>2</sup>(15G)</li> <li>Duration: 11ms</li> <li>Half-sine, 3 times each direction per each axis</li> </ul>	IEC61131-2			
7	Noise resistance	Square wave Impulse noise	AC: ± 1,500V DC: ± 900V		LS ELECTRIC standard	
		Electrostatic discharge	Voltage : 4kV (contact discharging)		IEC 61131-2, IEC 61000-4-2	
		Radiated electromagnetic field noise	80 ~ 1,000 MHz, 10V/m		IEC 61131-2, IEC 61000-4-3	
		Fast transient /bust noise	Segment	Power supply module	Digital/analog input/output communication interface	IEC 61131-2, IEC 61000-4-4
Voltage	2kV		1kV			
8	Environment	Free from corrosive gasses and excessive dust		-		
9	Altitude	Up to 2,000 ms		-		
10	Pollution degree	Less than equal to 2		-		
11	Cooling	Air-cooling		-		

### 9.2.2 Performance specifications

Here describes performance specification of analog output module.

Item		Specification		
No. of channels		2 channels		
Analog output range	Type	Voltage	Current	
	Range	DC 0 ~ 10V (Load resistance: 2k $\Omega$ Min.)	DC 4 ~ 20mA DC 0 ~ 20mA (Load resistance: 450 $\Omega$ Max.)	
		Output range can be set at user program or I/O parameter for each channel		
Digital input	Type	12-bit binary data		
	Range	Unsigned value	0~4000	
		Signed value	-2000 ~ 2000	
		Precise value	0 ~ 1000 (DC0~10V)	400 ~ 2000 (DC4~20mA) 0 ~ 2000 (DC0~20mA)
		Percentile value	0 ~ 1000	
Maximum resolution		1/4000 (DC 4 ~ 20mA: 1/3200)		
		2.5mV (DC 0 ~ 10V)	5 $\mu$ A (DC 0~20mA) 6.25 $\mu$ A (DC 4~20mA)	
Accuracy		$\pm$ 1.0% or less		
Maximum conversion speed		1ms/channel + scan time		
Additional function		Channel output state setting (former, min, middle, max value) Gain adjustment function		
Insulation method		no insulation between analog output channels no insulation between output terminal and PLC main unit		
I/O terminal		5-point terminal block		
Power supply		Internal 5V		
I/O points occupied		Fixed type: 64 points		
Supply power		Internal DC5V		
Current consumption		150mA		
Weight		20g		

Note1) In order to use analog output option board, the following version is needed.

Main unit	Version information
XBC E type	V1.1 or above
XBC S type	V1.1 or above
XBC SU type	V1.0 or above
XEC E type	V1.0 or above
XEC SU type	V1.0 or above
XG5000	V.3.61 or above

Note2) Offset/gain value on analog I/O range can be adjusted at XG5000 - I/O parameter

### 9.3 Designations and Functions

Here describes designation and functions.

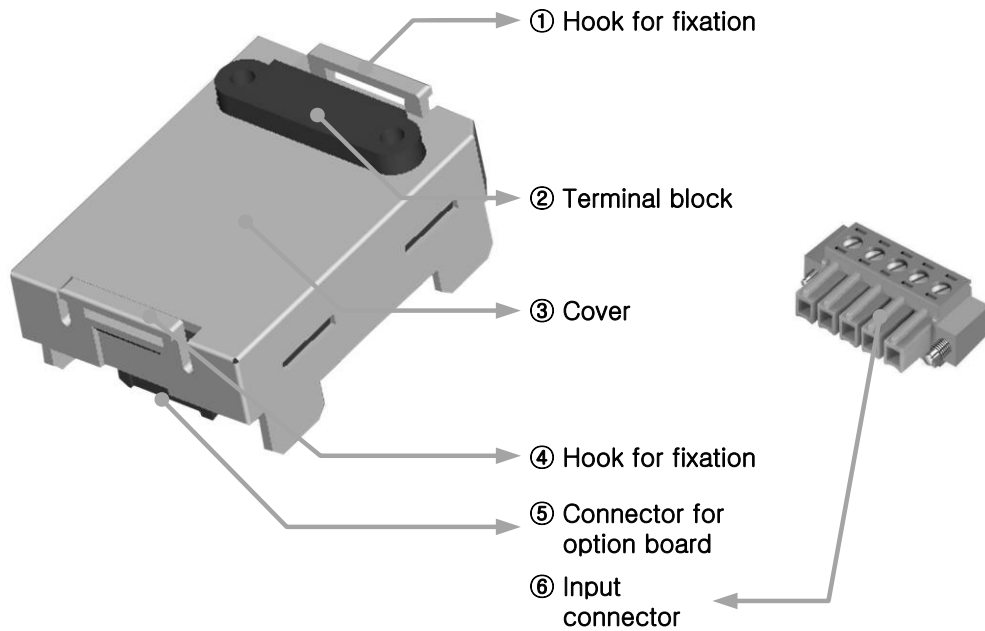

No.	Name	Description
①④	Hook for fixation	▶ Hook for fixing the option board to main unit
②	Terminal block	▶ Wiring terminal block to connect with external device (Analog input)
③	Cover	▶ Option board cover
⑤	Connector for option board	▶ Connection connector for connecting the option board to the main unit
⑥	Input connector	▶ Wiring connector for connecting with the external device



## 9.4 Characteristic of I/O Conversion

The output ranges of voltage and current can be set up per channel with user program or I/O parameters. The input types of digital data are defined as follows.

- (1) Unsigned Value
- (2) Signed Value
- (3) Precise Value
- (4) Percentile Value

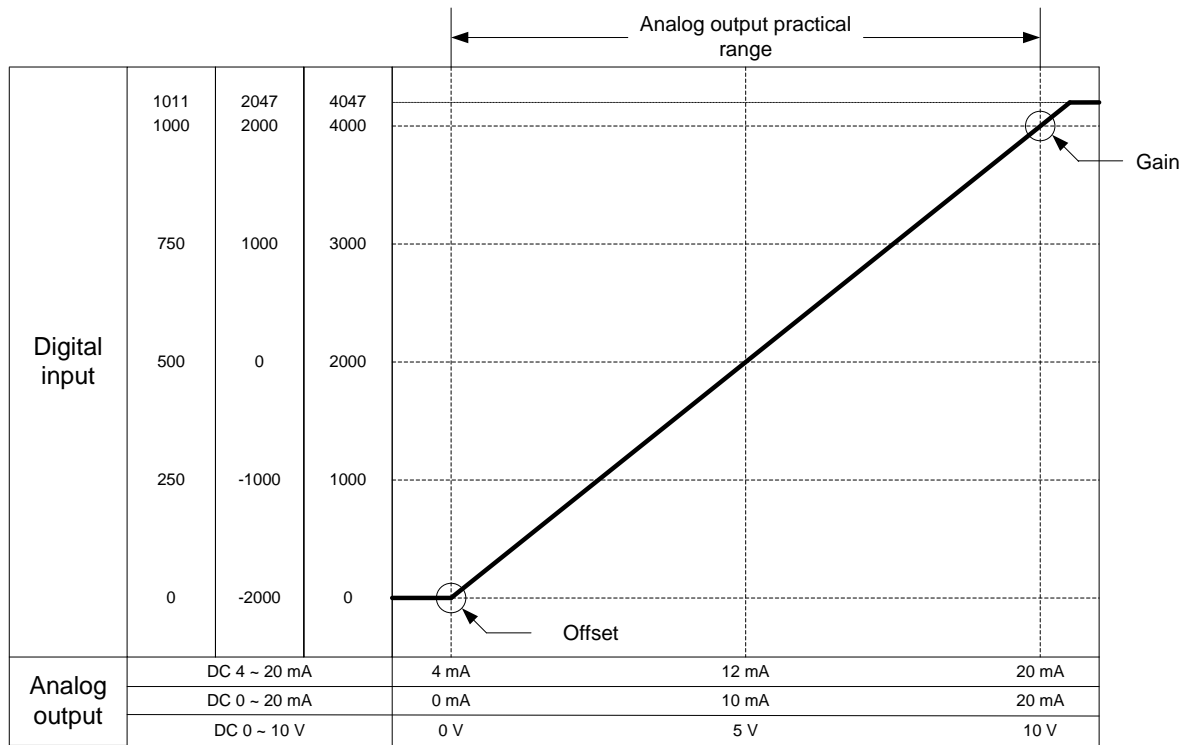

(1) DC4~20mA range output

Digital input range	Analog output current (mA)						
	4mA or less	4	8	12	16	20	Over 20mA
Unsigned value (0 ~ 4000)	0 or less	0	1000	2000	3000	4000	Over 4000
Signed value (-2000 ~ 2000)	-2000 or less	-2000	-1000	0	1000	2000	Over 2000
Precise value (400 ~ 2000)	400 or less	400	800	1200	1600	2000	Over 2000
Percentile value (0 ~ 1000)	0 or less	0	250	500	750	1000	Over 1000

## (2) DC 0 ~ 20mA range output

Digital input range	Analog output current (mA)						
	0mA or less	0	5	10	15	20	Over 20mA
Unsigned value (0 ~ 4000)	0 or less	0	1000	2000	3000	4000	Over 4000
Signed value (-2000 ~ 2000)	-2000 or less	-2000	-1000	0	1000	2000	Over 2000
Precise value (0 ~ 2000)	0 or less	0	500	1000	1500	2000	Over 2000
Percentile value (0 ~ 1000)	0 or less	0	250	500	750	1000	Over 1000

## (3) DC 0 ~ 10V range output

Digital input range	Analog output voltage (V)						
	0V or less	0	2.5	5	7.5	10	Over 10V
Unsigned value (0 ~ 4000)	0 or less	0	1000	2000	3000	4000	Over 4000
Signed value (-2000 ~ 2000)	-2000 or less	-2000	-1000	0	1000	2000	Over 2000
Precise value (0 ~ 1000)	0 or less	0	250	500	750	1000	Over 1000
Percentile value (0 ~ 1000)	0 or less	0	250	500	750	1000	Over 1000

**Note**

(1) There is "Dead Band" area around voltage output (0V), current output (0mA).

(a) Digital input-based: about 0 ~ 10

(b) Analog output-based: voltage (about 0 ~ 25 mV), current (about 0 ~ 50  $\mu$ A)

(2) In "Dead Band" area, digital input and analog output may not coincide (within accuracy)

## 9.5 Accuracy

Accuracy for analog output value does not change even if output range is changed. Figure below shows the range of the accuracy with analog output range of 0 ~ 10 V and digital output type of unsigned value selected.

Accuracy of XBO-DA02A is  $\pm 1.0\%$ .

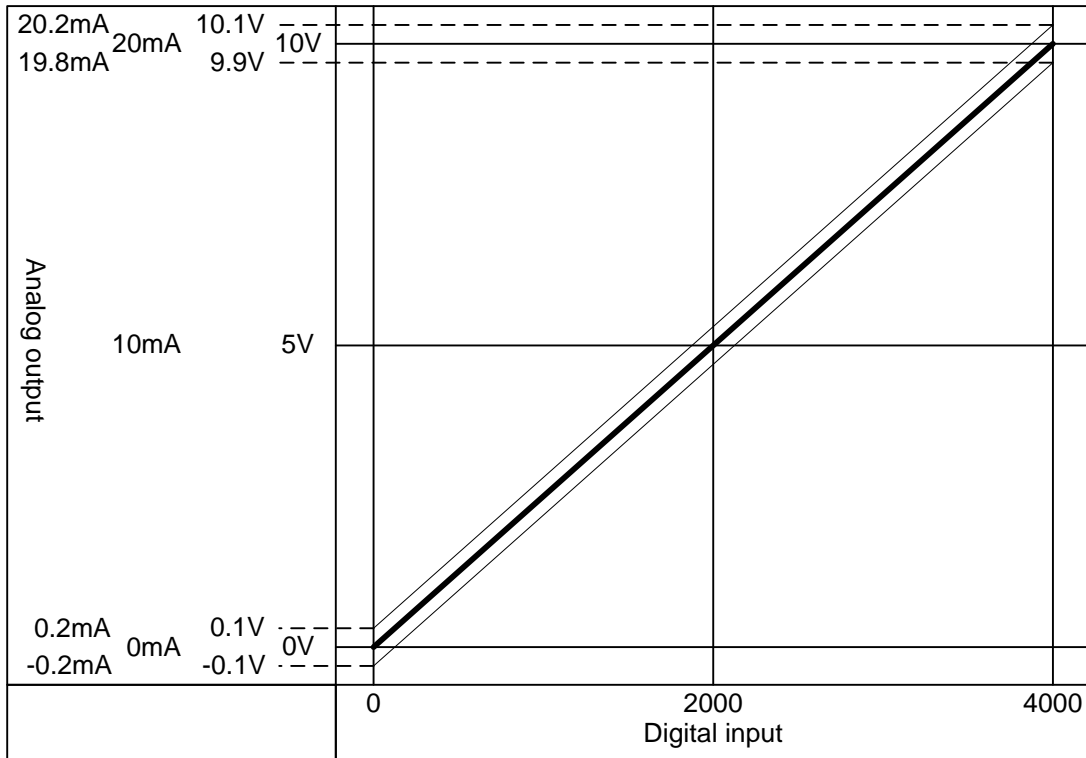

(1) Accuracy in case of 5V output

$$4000 \times 1.0\% = 40$$

So in case of 5V output, accuracy range is  $(5V - 40 \times 0.0025V) \sim (5V + 40 \times 0.0025V) = 4.9 \sim 5.1V$

(2) Accuracy in case of 10V

$$4000 \times 1.0\% = 40$$

So in case of 10V output, accuracy range is  $(10V - 40 \times 0.0025V) \sim (10V + 40 \times 0.0025V) = 9.9 \sim 10.1V$

## 9.6 Functions of Analog Output Option Board

Here describes functions of XBO-DA02A option board

Function	Details
Enable/Disable channel	1) It sets up Run/Stop of a channel that will operate an analog output. 2) You can save the time of whole operation by stopping unused channels.
The range of output voltage/current	1) It sets up the range of an analog output. 2) Analog output option board offers one voltage output (DC 0 ~ 10V) and two current output (DC 4 ~ 20mA, DC 0 ~ 20mA).
The input data type	1) It sets up the type of a digital input. 2) It offers four types of a digital input. (Unsigned value, signed value, precise value, percentile value)
The status of output	1) It sets up the output status of a channel when it switches Run to Stop. 2) It offers four types of output status. (Former, min, middle, max value)

### 9.6.1 Channel Output State Setting Function

It sets output against PLC stop and abnormal state

(1) Function

It is used to output an already set value when PLC system switches RUN to Stop

(2) Type

You can select one among former, min, middle and max value.

- (a) Former value: keeps last normal output value
- (b) Min. value: outputs minimum value of the each output range
- (c) Middle value: outputs middle value of the each output range
- (d) Max. value: outputs max. value of the each output range.

(3) Example

When output is 10mA and range of output channel is 4~20mA, if system switches Run to Stop, it outputs as follows according to output state setting.

- (a) Former value: keeps previous output, 10mA
- (b) Min. value: outputs min. value of corresponding range, 4mA.
- (c) Middle value: outputs middle value of corresponding range, 12mA
- (d) Max. value: outputs max. value of corresponding range, 20mA.

### 9.6.2 Gain Adjustment Function

You can adjust output gain of the analog output option board.

When selecting current output for analog output range, the digital input (4000) corresponding to analog output max. value (20mA) is standard gain value. When selecting voltage output, the digital input (4000) corresponding to analog output max. value (10V) is standard gain value.

- (1) You can adjust output gain at I/O parameter
- (2) Output gain setting range = - 40 ~ 40
- (3) Adjusting gain for each channel is available

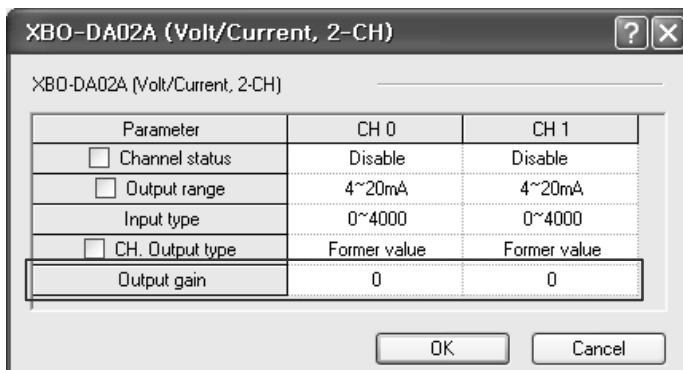

- (4) Example  
When you set "Output gain" as -5, 4,005 (=4000- (-5)) applies for gain.

**Note**

- (1) When you adjust the output gain, max. resolution changes, too.

## 9.7 Wiring

### 9.7.1 Precautions for wiring

- (1) Don't let AC power line at close range to output option board to prevent a surge or inductive noise from the A.C. side.
- (2) Select the cable with consideration of an ambient temperature and a permitted current limit. It is recommended over AWG22 (0.3mm<sup>2</sup>).
- (3) Don't let the cable at close range to hot devices or materials. And don't bring it into contact with oil for a long time. These are the factors of a short circuit occurs unusual operation or damages devices.
- (4) Check the polarity before external power is supplied to the terminal.
- (5) It may produce inductive hindrance that is a cause of unusual operations or defects if you wire the cable with a high-voltage line or a power line.
- (6) Enable the only channel you want to use

### 9.7.2 Wiring example

- (1) Current output

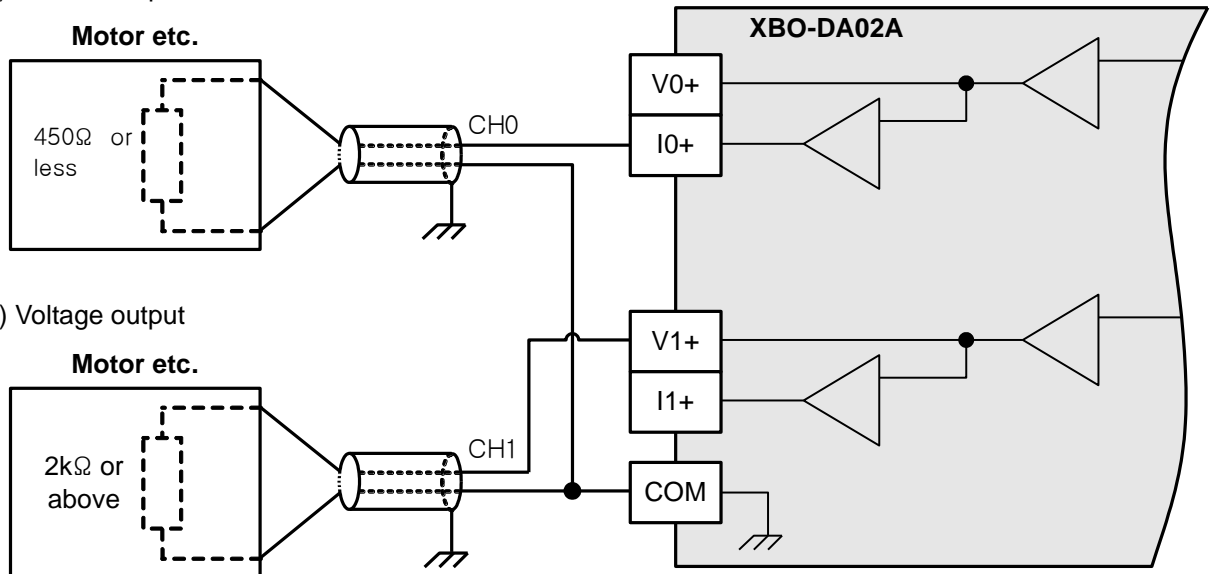

- (3) Terminal block configuration

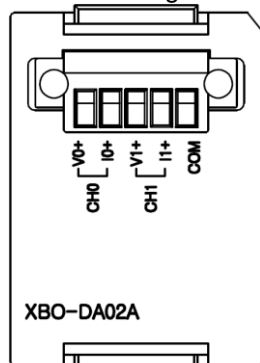

## 9.8 Operation Parameter Setting

You can specify operation parameters of the analog output option board through [I/O parameters] menu in XG5000.

(1) Setting items

For the user's convenience, XG5000 provides GUI (Graphical User Interface) for parameters setting of analog output option board.

Followings are available through [I/O parameters] on the XG5000 project window.

Item	Details
[I/O Parameters]	<p>(1) Parameter setting</p> <p>It specifies the following items for the option board operation.</p> <ul style="list-style-type: none"> <li>- Channel Enable/Disable</li> <li>- Analog output range (Voltage/current)</li> <li>- Input data type</li> <li>- Channel output type</li> <li>- Output gain</li> </ul> <p>(2) After the parameters that user specified in XG5000 are downloaded, they will be saved to a flash memory in the XGB main unit.</p>

(2) How to use [I/O Parameters] menu

(a) Run XG5000 to create a project. (Refer to XG5000 program manual for details on how to create the project)

(b) Double-click [I/O Parameters] on the project window.

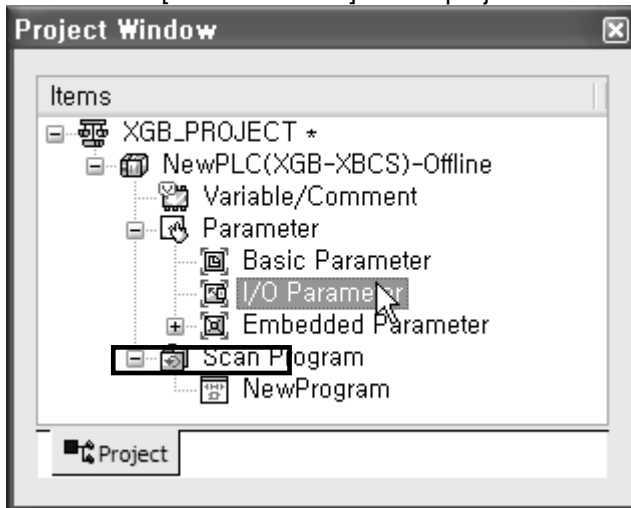

(c) Click the slot of the base that contains analog output option board in the [I/O Parameter Setting] window.

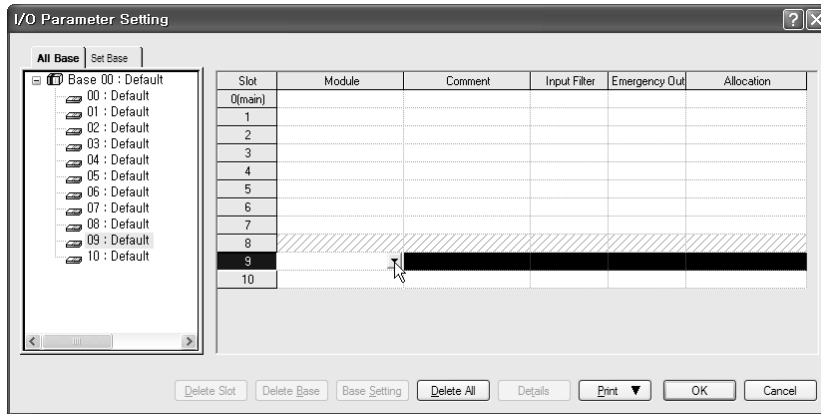

(d) Click the arrow button then you can see the menu to choose the applicable module. Select the applicable option board.

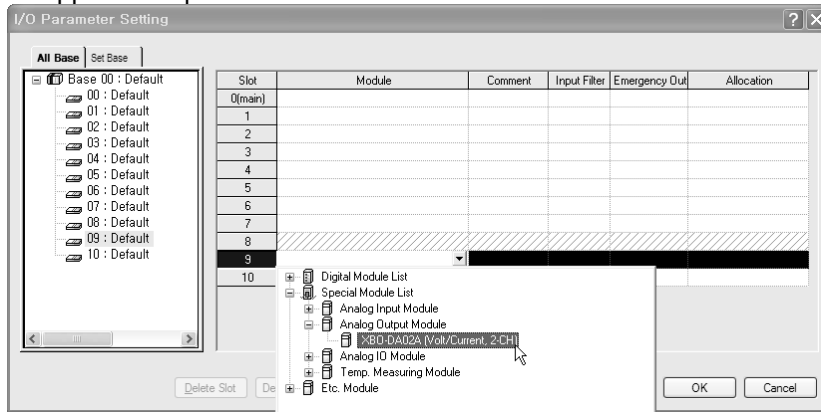

(e) Double-click the applicable slot that is selected for the parameters setting or click [Details].

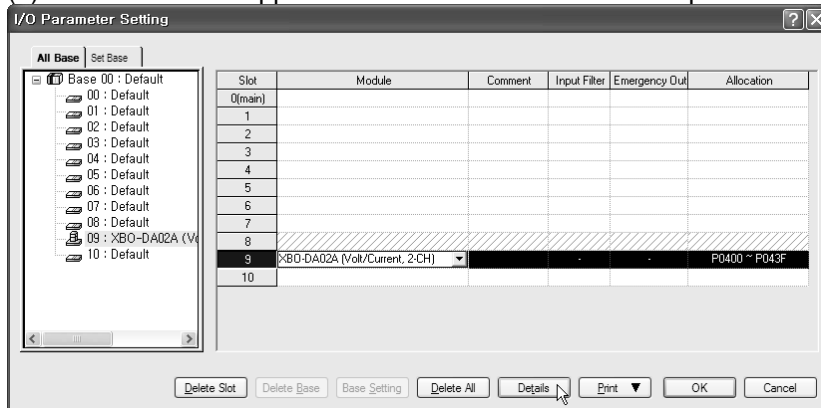



(f) A screen will be displayed for you to specify parameters for respective channels as shown below. Click a desired item to display parameters to set for respective items.

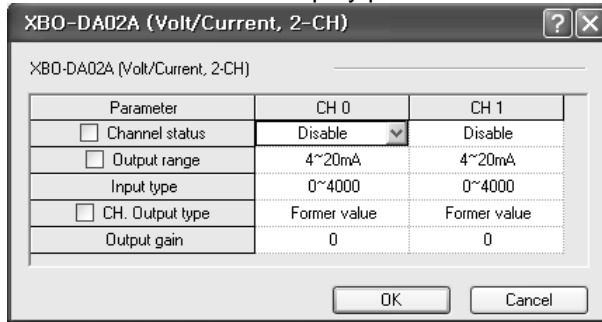

## 9.9 Special Module Monitoring Function

The function of the special module monitor is as follows.

(1) Start of [Special Module Monitoring]

Go through [Online] → [Connect] and [Monitor] → [Special module Monitoring] to start. If the status is not online, [Special Module Monitoring] menu will not be activated.

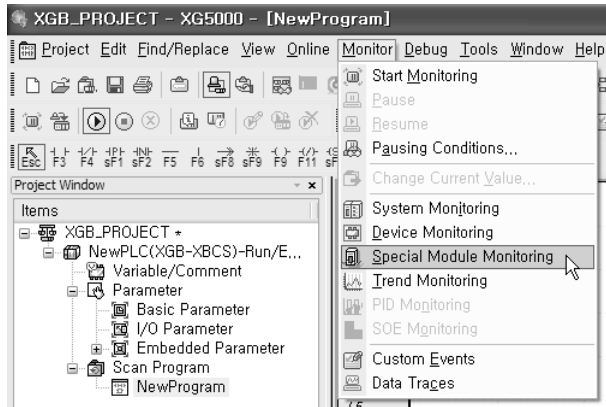

**Note**

- 1) The screen may not function properly if the system resources are not sufficient. In this case, close the screen, exit other applications, and rerun XG5000.
- 2) The I/O parameters set up in [Special Module Monitor] condition are temporarily set up for testing purpose. Therefore, these I/O parameters are deleted after exit from [Special Module Monitor].
- 3) The test function of the [Special Module Monitor] enables testing analog output option board without sequence programming.

(2) How to use [Special Module Monitoring]

- (a) Connecting XG5000 with PLC basic unit, [Special Module List] window will show base/slot information and types of special module by click [Monitor] → [Special Module Monitoring]. Special Module List will display the modules that are installed in PLC now.

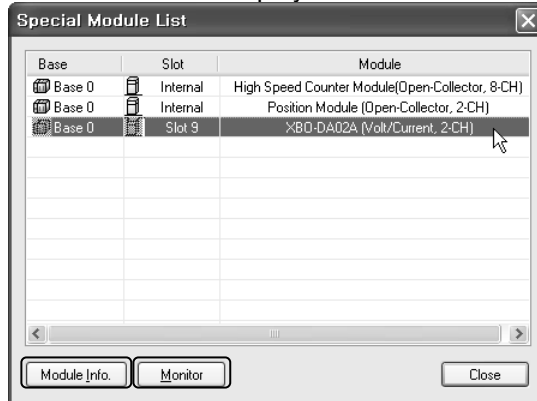

- (b) Select a special module then click [Module Info.] button to display the information as described below.

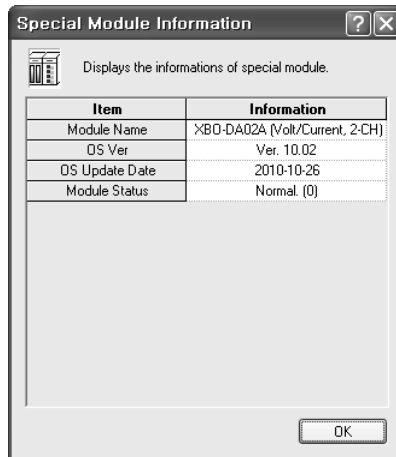

- (c) Click [Monitor] button in the [Special Module List] window to display the [Special Module Monitor] window as below

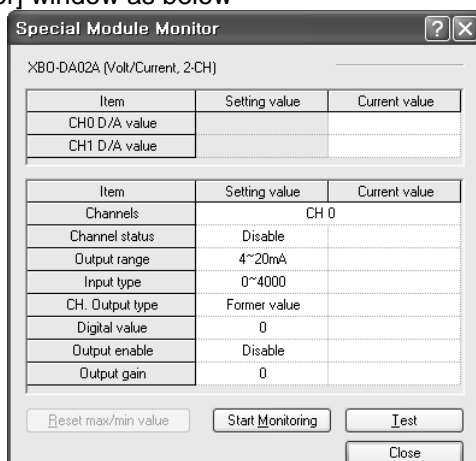

(d) [Start Monitoring] button will show you digital input data of the operating channel.

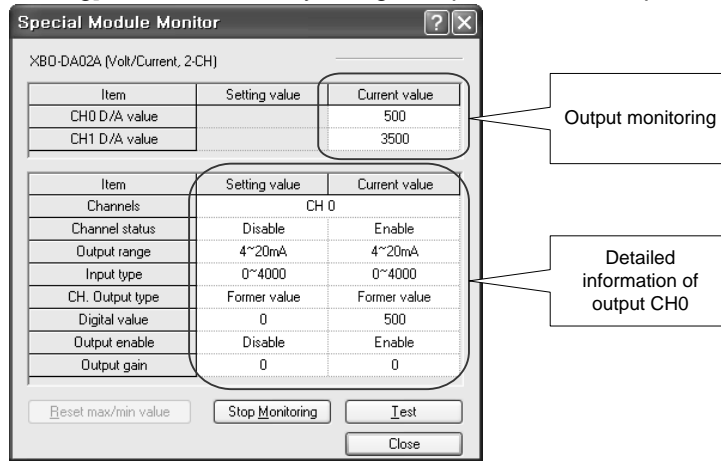

[Start Monitoring] execution screen

(e) [Test] is used to change the parameters of the voltage output module. You can change the parameters when you click the values at the bottom of the screen. It is only available when XGB CPU unit's status is in [Stop Monitoring].

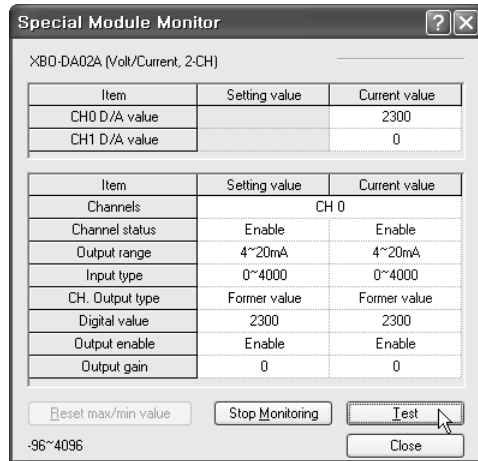

[Test] execution screen

(f) [Close] is used to escape from the monitoring/test screen. When closing the "Monitoring/Test" screen, the setting value is not saved anymore.

## 9.10 Register U devices (special module variable)

Register the variables for each option board referring to the special module information that is set in the I/O parameter. The user can modify the variables and comments.

(1) Registration sequence

(a) Select a special module type in [I/O Parameter Setting] window.

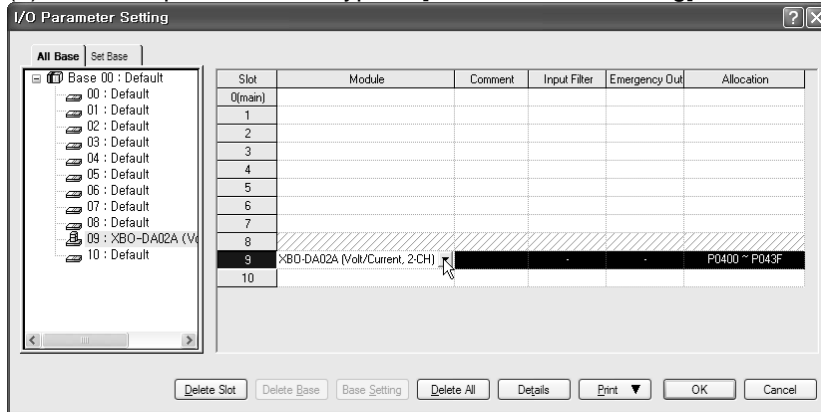

(b) Double-click [Variable/Comment] from the project window.

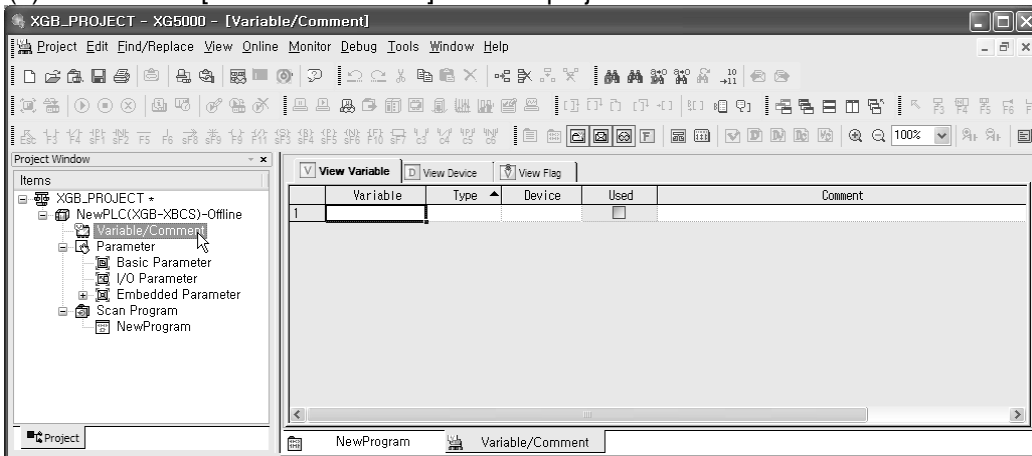

(c) Select [Edit] → [Register U Device].

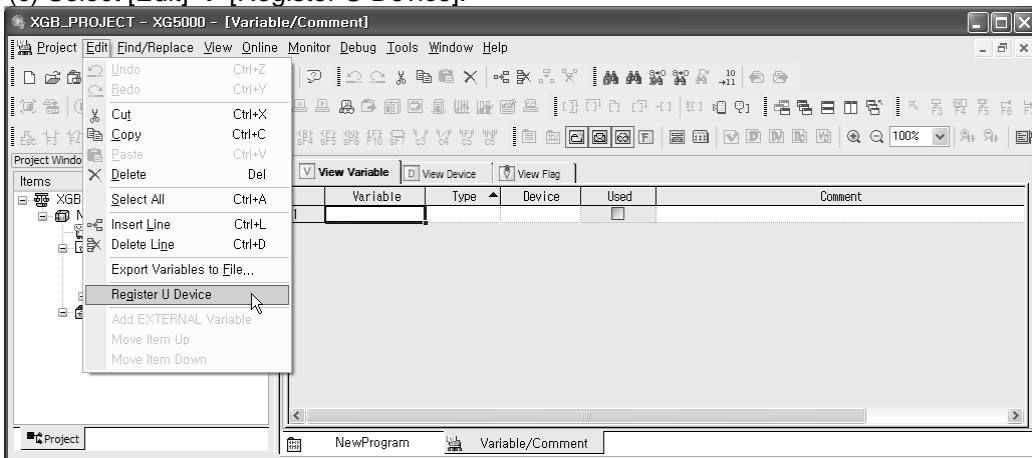

(d) Click 'Yes'.

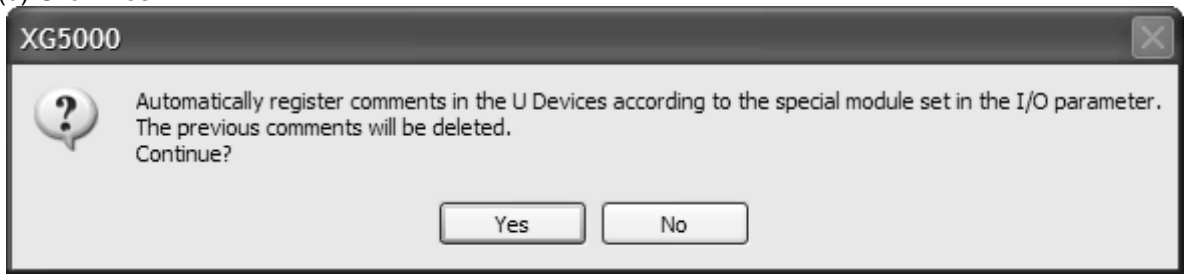

(e) As shown below, the variables are registered.

	Variable	Type	Device	Used	Comment
1	_09_ERR	BIT	U09.00.0	<input type="checkbox"/>	Analog Output Option Board: Error
2	_09_RDY	BIT	U09.00.F	<input type="checkbox"/>	Analog Output Option Board: Ready
3	_09_DAO_ACT	BIT	U09.01.2	<input type="checkbox"/>	Analog Output Option Board: Output CHO Active
4	_09_DA1_ACT	BIT	U09.01.3	<input type="checkbox"/>	Analog Output Option Board: Output CH1 Active
5	_09_DAO_ERR	BIT	U09.01.A	<input type="checkbox"/>	Analog Output Option Board: Output CHO Error
6	_09_DA1_ERR	BIT	U09.01.B	<input type="checkbox"/>	Analog Output Option Board: Output CH1 Error
7	_09_DAO_OUTEN	BIT	U09.06.0	<input type="checkbox"/>	Analog Output Option Board: Output CHO Status Setting
8	_09_DA1_OUTEN	BIT	U09.06.1	<input type="checkbox"/>	Analog Output Option Board: Output CH1 Status Setting
9	_09_DAO_DATA	WORD	U09.07	<input type="checkbox"/>	Analog Output Option Board: Output CHO DATA
10	_09_DA1_DATA	WORD	U09.08	<input type="checkbox"/>	Analog Output Option Board: Output CH1 DATA

(2) Save variables

- (a) The contents of 'View Variables' can be saved as a text file
- (b) Click [Edit] → [Export to File].
- (c) The contents of 'View Variable' are saved as a text file.

(3) View variables in a program

The figure below present examples of use in XGB compact “E” and “S” types

(a) The example of XG5000 is shown below.

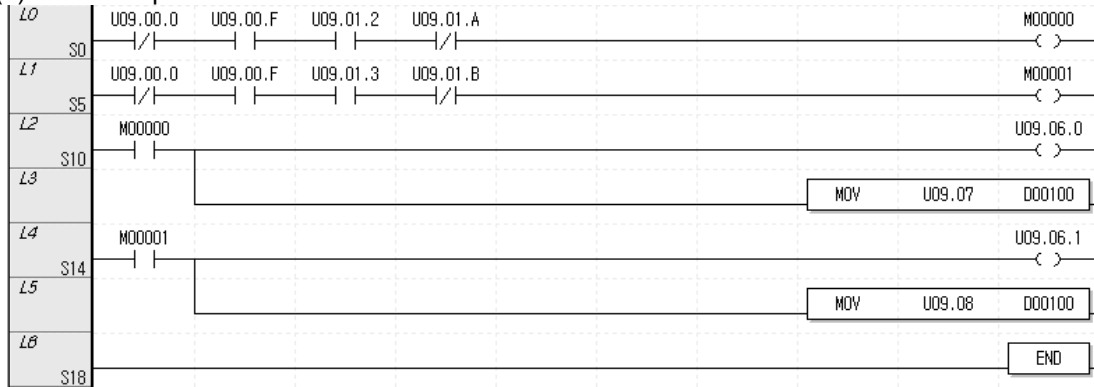

(b) Select [View] → [Variables]. The devices are changed into variables.

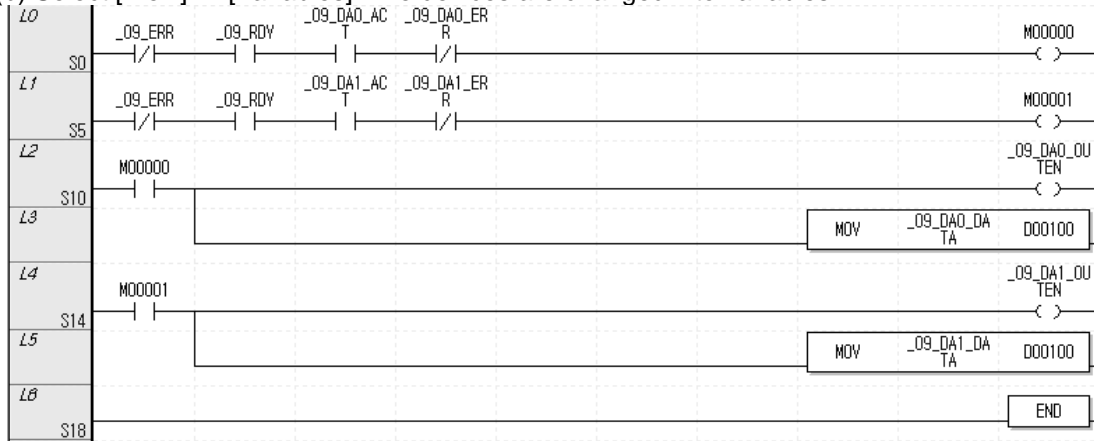

(c) Select [View] → [Devices/Variables]. Device and variable both are displayed.

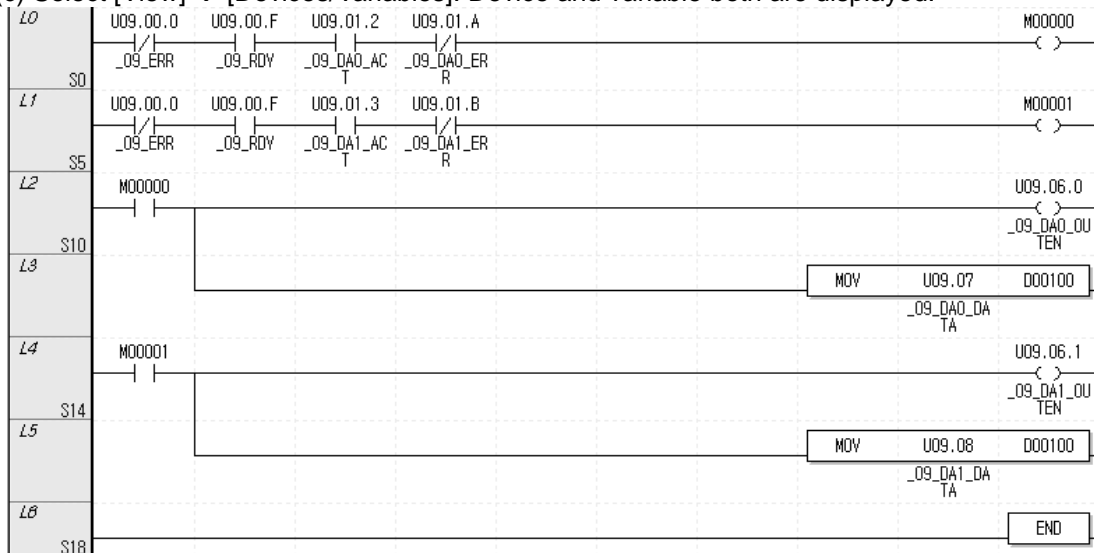

(d) Select [View] → [Devices/Comments]. Device and comment both are displayed.

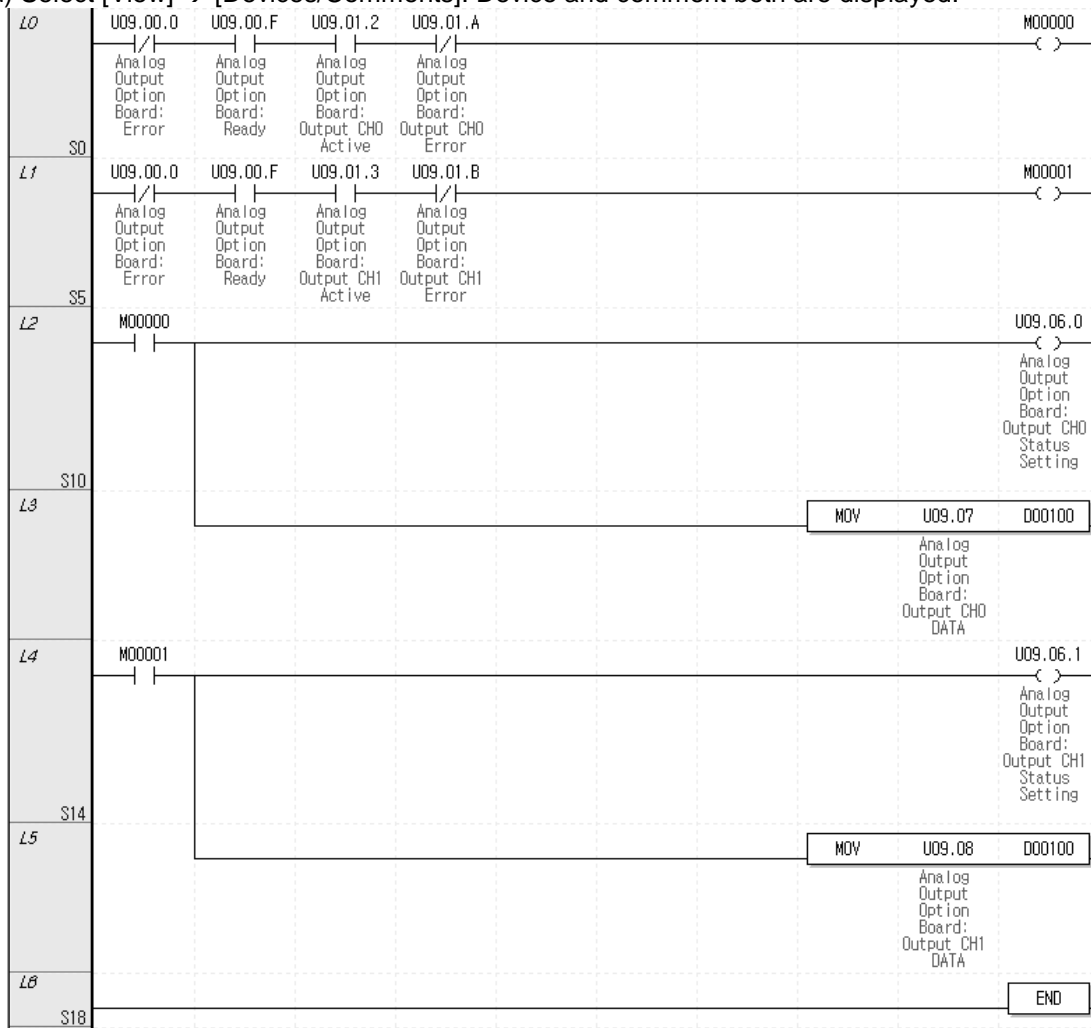

(e) Select [View] → [Variable/Comments]. Variable and comment both are displayed.

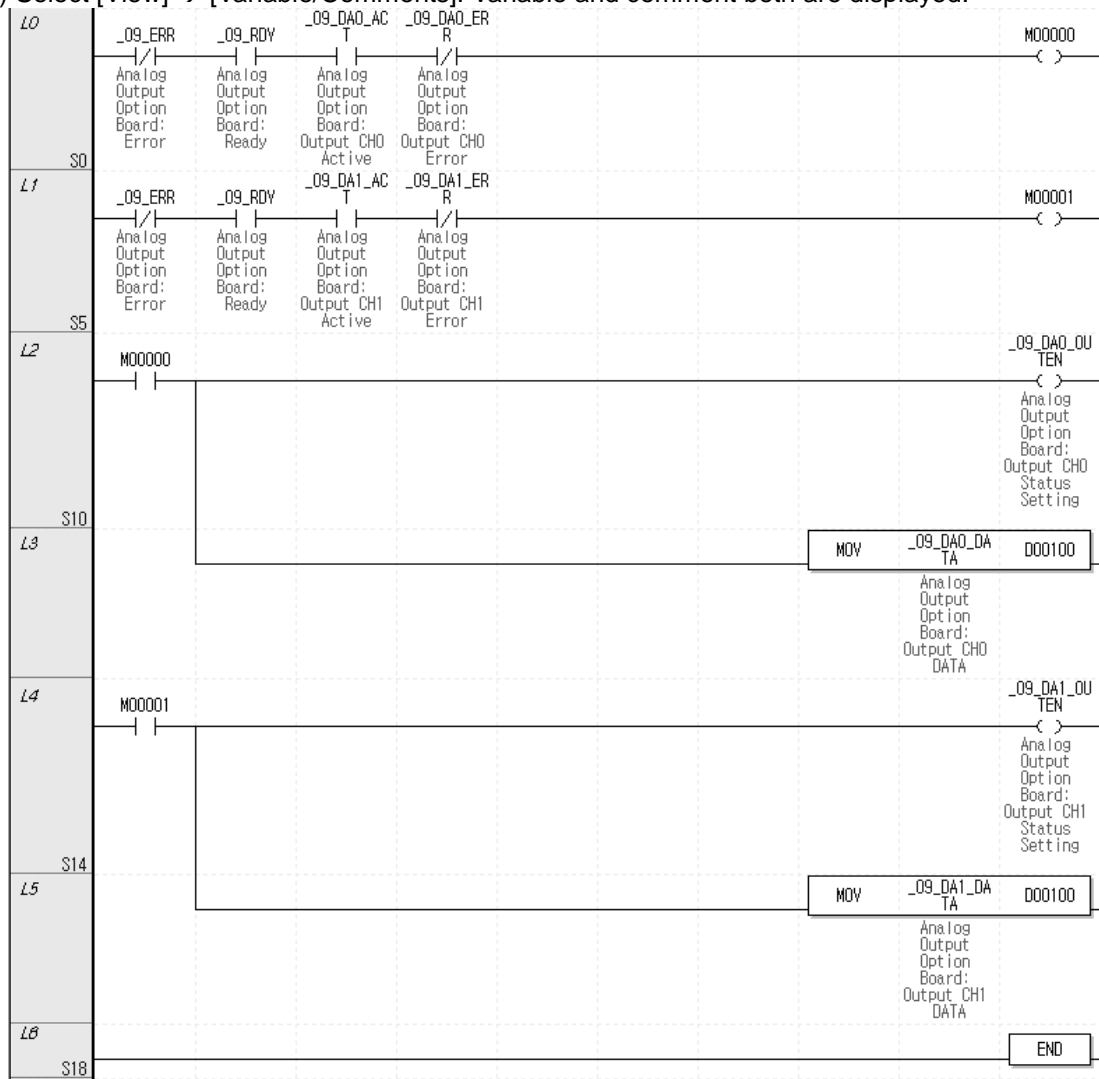



## Chapter 9 Analog Output Option (XBO-DA02A)

(f) For IEC type also, as shown in Fig. (a) ~ (e), you can look up variables with diversified options in the 'View' menu. The figure below is the case of an IEC type with which the 'View Device/Variables' option.

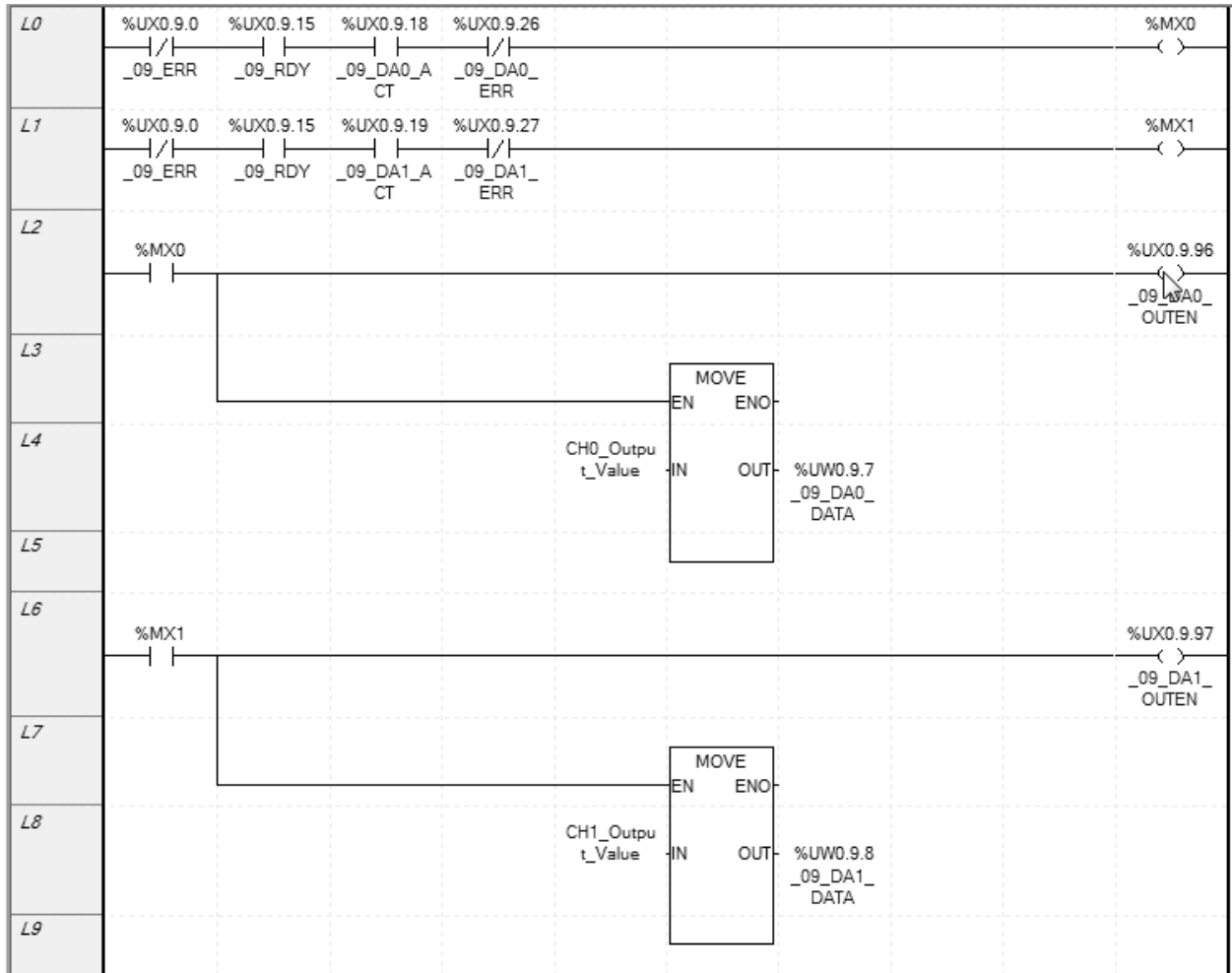

**9.11 Internal memory**

Describes configuration and function of internal memory

**9.11.1 Data I/O area**

Describes data I/O area

Variable name	Type	Device assignment		Description	R/W	Signal direction
		XBC	IEC			
_0y_ERR	BIT	U0y.00.0	%UX0.y.0	Module Error	R	Option → CPU
_0y_RDY	BIT	U0y.00.F	%UX0.y.15	Module Ready		
_0y_DA0_ACT	BIT	U0y.01.2	%UX0.y.16	CH0 active	R	Option → CPU
_0y_DA1_ACT	BIT	U0y.01.3	%UX0.y.17	CH1 active		
_0y_DA0_ERR	BIT	U0y.01.A	%UX0.y.20	CH0 error	R	Option → CPU
_0y_DA1_ERR	BIT	U0y.01.B	%UX0.y.21	CH1 error		
_0y_DA0_OUTEN	BIT	U0y.06.0	%UX0.y.24	CH0 output state setting	W	Option ↔ CPU
_0y_DA1_OUTEN	BIT	U0y.06.1	%UX0.y.25	CH1 output state setting		
_0y_DA0_DATA	WORD	U0y.07	%UW0.y.4	CH0 input value	W	Option ↔ CPU
_0y_DA1_DATA	WORD	U0y.08	%UW0.y.5	CH1 input value	W	Option ↔ CPU

- In the device allocation, the small letter 'y' is the No. of the slot where the module is installed.
- For example, to Write the 'CH0 Output A/D Value' of the analog module installed in the slot 9, write in U09.07 (%UW0.9.7 for IEC types)

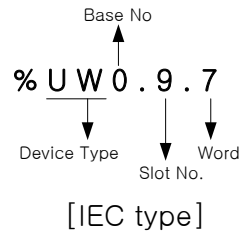
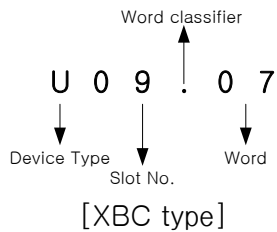

- (1) Module Ready/Channel Error information ( ( ) is for IEC types, y: slot No.)
  - (a) U0y.00.F(%UX0.y.15): It will be ON when PLC CPU unit is powered or reset with the condition that an analog option board has prepared to convert.
  - (b) U0y.00.0(%UX0.y.0): It is the flag which displays error status of each channel in the analog option board.

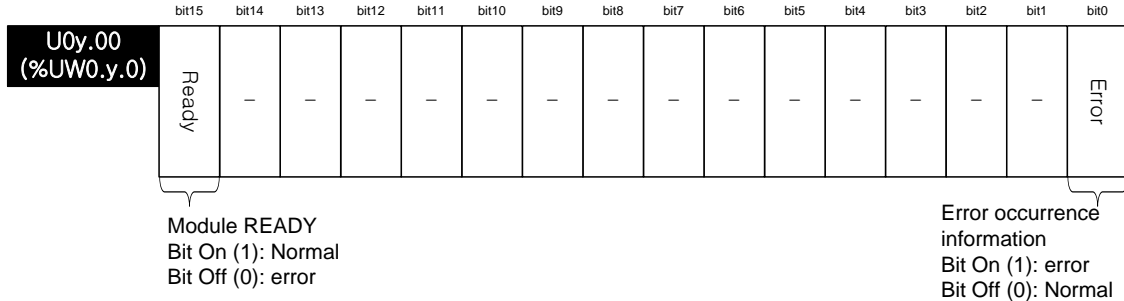

- (2) Channel operation information ( ( ) is for IEC types, y: slot No.)
  - (a) This area is used to display the channel being used and channel error information.

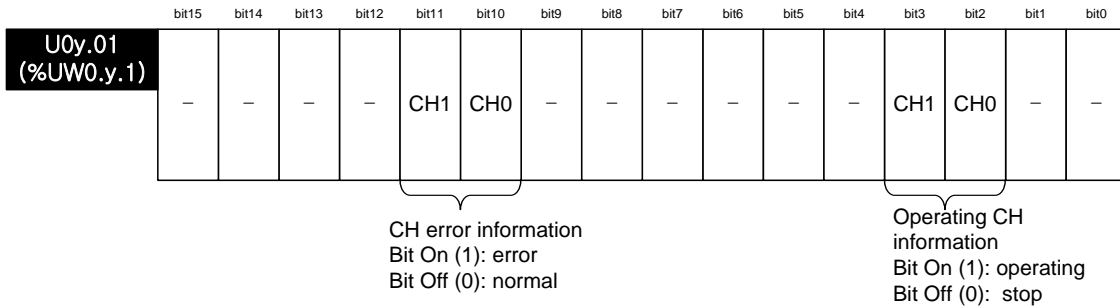

- (3) Output setting ( ( ) is for IEC types, y: slot No.)
  - (a) Each channel can be specified enable/disable the analog output.
  - (b) If the output is not specified, output of all the channels will be disabled.



- (4) Digital input ( ( ) is for IEC types, y: slot No.)
  - (a) Digital input value can be selected and used within the range of unsigned value (0~4047), signed value (-2000~2047), precise value and percentile value (0~1011) based on input type.
  - (b) If the digital input value is not specified, it will be set to 0.



## 9.11.2 Setting area of operation parameters

Memory address	Description	Setting value	R/W	Instruction
0	Enable CH	Bit Off (0): disable, bit On (1): enable	R/W	PUT/GET
1	Output range setting	Input range setting (4 bit per channel) 0: 4 ~ 20 mA 1: 0 ~ 20 mA 2: 0 ~ 10 V	R/W	
2	Input data type setting	Input data type setting (4 bit per channel) 0: 0 ~ 4000 1: -2000 ~ 2000 2: Precise value 3: 0 ~ 1000 - In case of precise value 4 ~ 20 mA: 400 ~ 2000 0 ~ 20 mA: 0 ~ 2000 0 ~ 10 V: 0 ~ 1000	R/W	
8	CH output state setting	CH output state setting (4bit per channel) 0: Former value 1: min value 2: middle value 3: max value	R/W	
11	Output CH0 gain weighting	-40 ~ 40	R/W	
12	Output CH1 gain weighting		R/W	
13	Setup error information	50#: output ch range setting error 60#: output ch data type setting error 70#: output ch output state setting error 80#: output ch gain weighting setting error 90#: output ch input value excess error (#: channel number)	R	GET

(1) Operating Channel Setting (address 0)

- (a) You can set "Enable/Disable" of analog output option board per each channel
- (b) Disable the unused channels to reduce the conversion period.
- (c) Default value is "Disable" for all channels
- (d) When using PUT instruction, address is as follows.

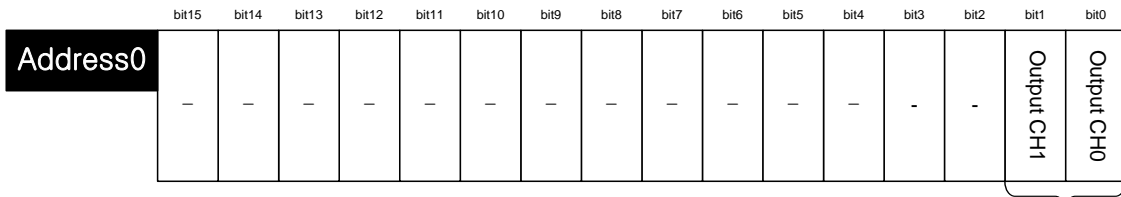

Enable CH  
 Bit On (1): enable  
 Bit Off (0): disable

- (e) The values set in bit 2~15 are ignored.
- (f) This area is same as setting in "Channel status" of I/O parameter

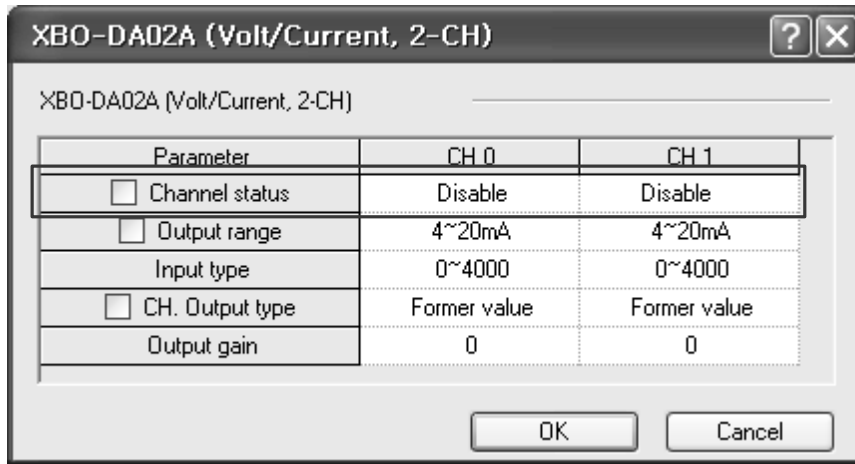

(2) Output range setting area (address 1)

(a) Set the type of output range with the following code

Bit (HEX)	Input range
0000 (0)	4 ~ 20 mA
0001 (1)	0 ~ 20 mA
0010 (2)	0 ~ 10 V

(b) If you set more than 3, 0 (4~20mA) will be set forcibly  
 But, U0X.01.A~ U0X.01.B (Setup error flag) will be ON.

(c) When using PUT instruction, address is as follows.

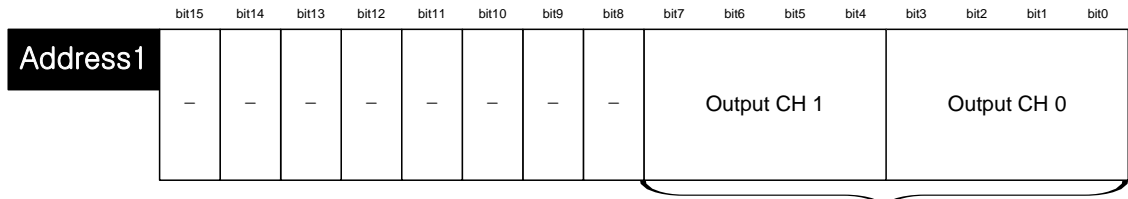

Output range (4bit per channel)  
 0 : 4 ~ 20 mA  
 1 : 0 ~ 20 mA  
 2 : 0 ~ 10 V

(d) The values set in bit 8~15 are ignored.

(e) This area is same as setting in "Output range" of I/O parameter

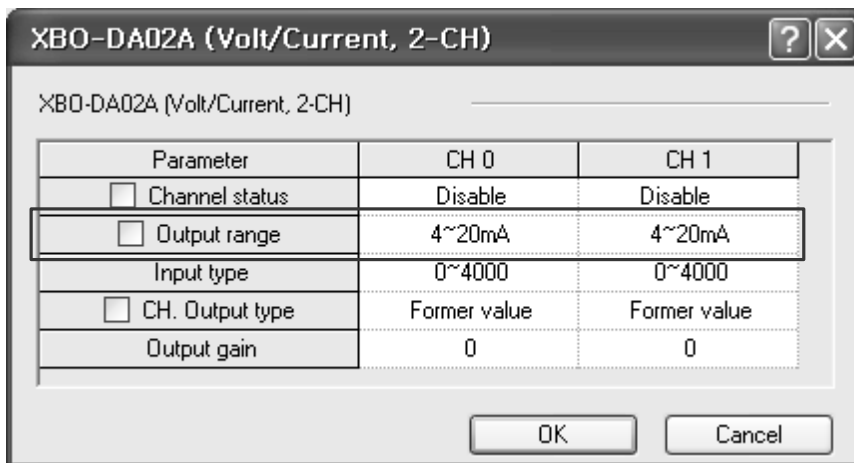

(3) Input data type setting area (address 2)

(a) Set the type of input data type with the following code

Bit (HEX)	Input data type
0000 (0)	0~4000
0001 (1)	-2000~2000
0010 (2)	Precise value
0011 (3)	0~1000

In case of precise value, input data type is designated as the following value according to each output range type

Output range	Precise value
4 ~ 20 mA	400 ~ 2000
0 ~ 20 mA	0 ~ 2000
0 ~ 10 V	0 ~ 1000

(b) If you set more than 4, 0 (0~4000) will be set forcibly.

But, U0X.01.A~ U0X.01.B (Setup error flag) will be ON.

(c) When using PUT instruction, address is as follows

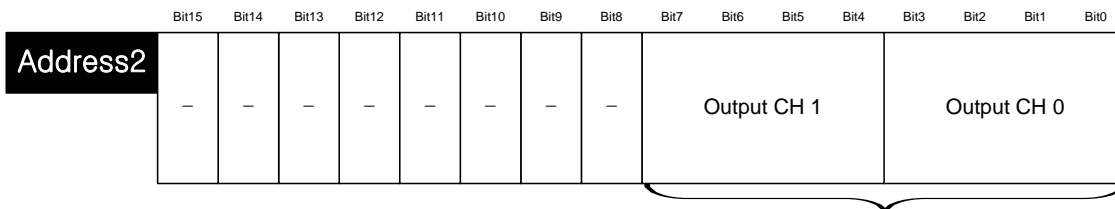

Input data type (4bit per channel)

- 0 : 0 ~ 4000
- 1 : -2000 ~ 2000
- 2 : precise value
- 3 : 0 ~ 1000

- In case of precise value
- 4 ~ 20 mA: 400 ~ 2000
- 0 ~ 20 mA: 0 ~ 2000
- 0 ~ 10 V: 0 ~ 1000

(d) The values set in bit 8~15 are ignored.

(e) This area is same as setting in "Input type" of I/O parameter

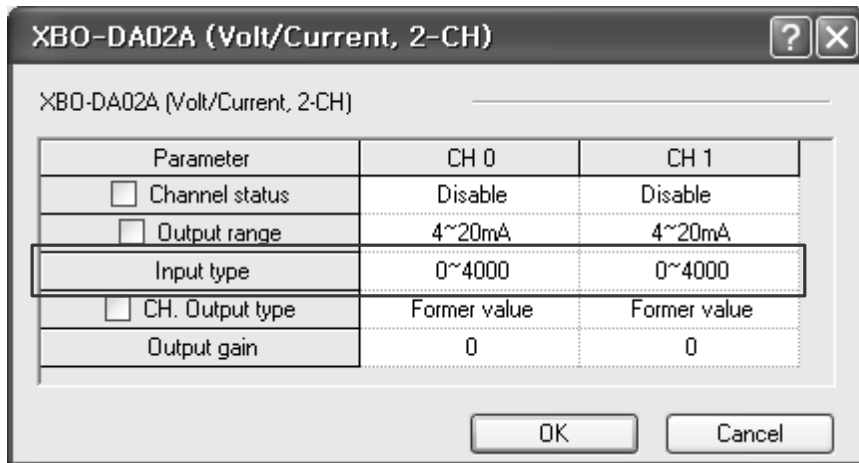

- (4) Channel output state setting area (address 8)  
 (a) Set the output state setting with the following code

Bit (Hex)	Channel output state
0000 (0)	Former value
0001 (1)	Min value
0010 (2)	Middle value
0011 (3)	Max value

- (b) If you set more than 4, 0 (former value) will be set forcibly.  
 But, U0X.01.A~ U0X.01.B (Setup error flag) will be ON.  
 (c) When using PUT instruction, address is as follows

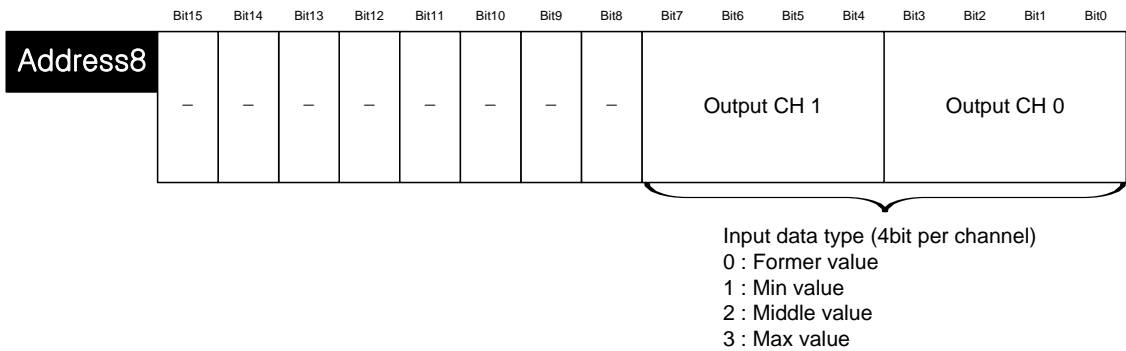

- (d) The values set in bit 8~15 are ignored.  
 (e) This area is same as setting in "CH. Output type" of I/O parameter

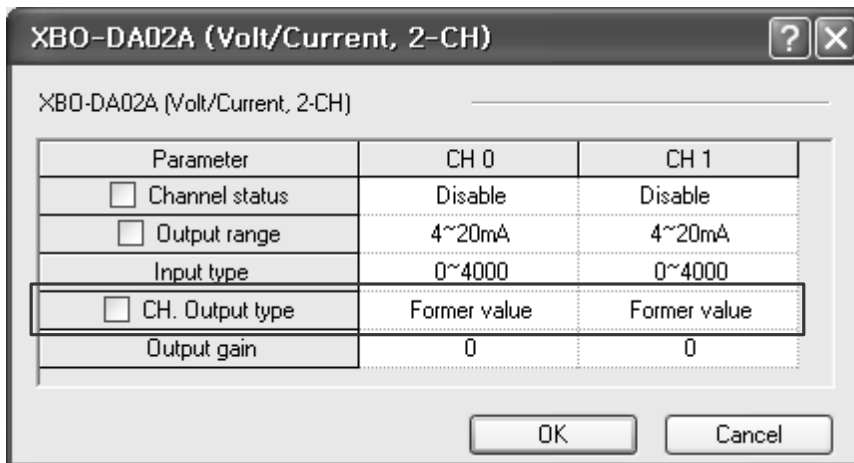



- (5) Output gain weighting setting area (address 11~12)
  - (a) Set output gain weighting with value of -40~40
  - (b) If you set this as 0 (default value), 4000 will apply for gain value
  - (c) For example, if you set this as -10, 4010 (=4000-(-10)) will apply for gain value
  - (d) When using PUT instruction, address is as follows

Address11	Output CH0 gain (-40 ~ 40)
Address12	Output CH1 gain (-40 ~ 40)

(e) This area is same as setting in "Output gain" of I/O parameter

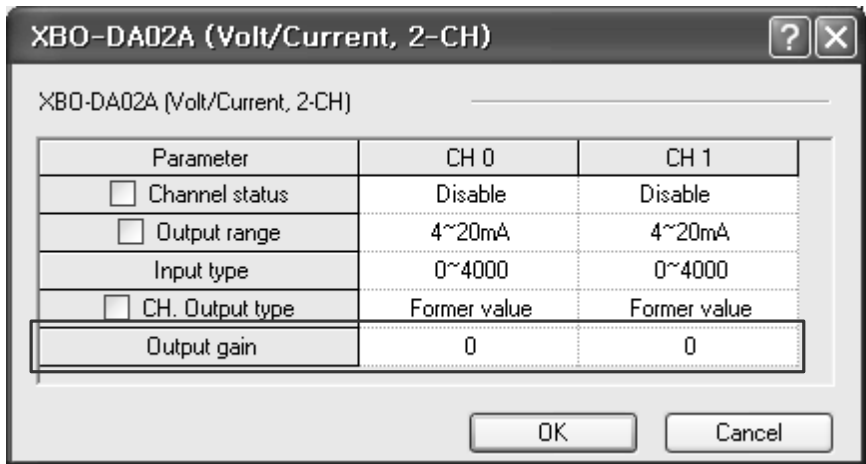

- (6) Setup error information output area (address 13)
  - (a) Saves error code detected when setting (setting by program)
  - (b) Setting error is canceled when value is reset to make it in the valid range
  - (c) When U0X.01.A~ U0X.01.B (setting error flat) is on, check that area and fix the corresponding setting to cancel the error
  - (d) When using GET instruction, address is as follows

Address13	Setting error information
-----------	---------------------------

Type	Error code	Description	Priority	Remark
Setting error	50#	Output CH range setting error	2	#: CH number Output CH 0,1
	60#	Output CH data type setting error	3	
	70#	Output CH state setting error	4	
	80#	Output CH gain weighting setting error	5	
	90#	Output CH input value excess error	1	

(e) When more than two errors occur simultaneously, it saves error code having higher priority.

## 9.12 Example Program

- (1) This sample program sets up operating parameters of analog output option board.
- (2) Initial settings are saved in the internal memory of the XGB main unit by one input.
- (3) The sample program below controls the I/O data of the analog output option board at option slot #0 (I/O slot #9) and check open wire.

### 9.12.1 Example of [I/O Parameter] Usage

- (1) I/O Parameter Setting Window

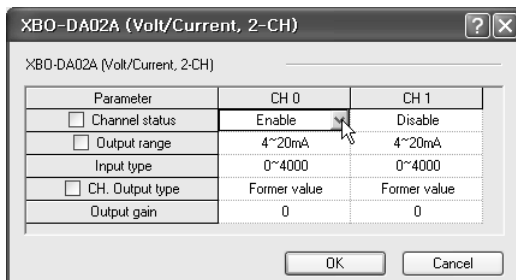
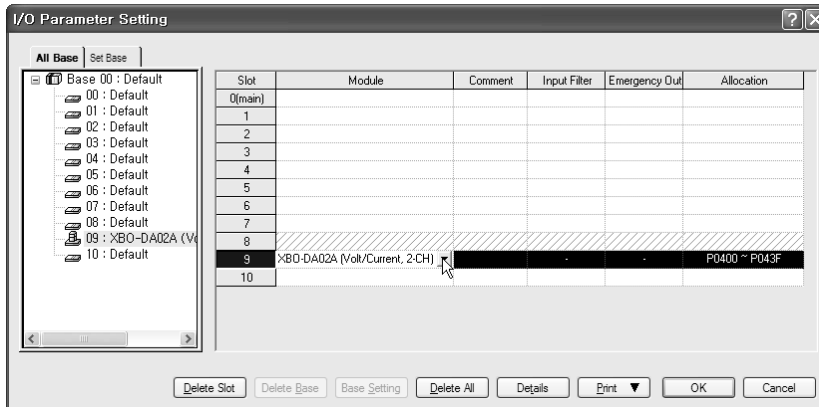

- (a) Output Channel 0 is set to operating channel and output range is set to 4~20mA.

(2) Sample Program(XBC Type)

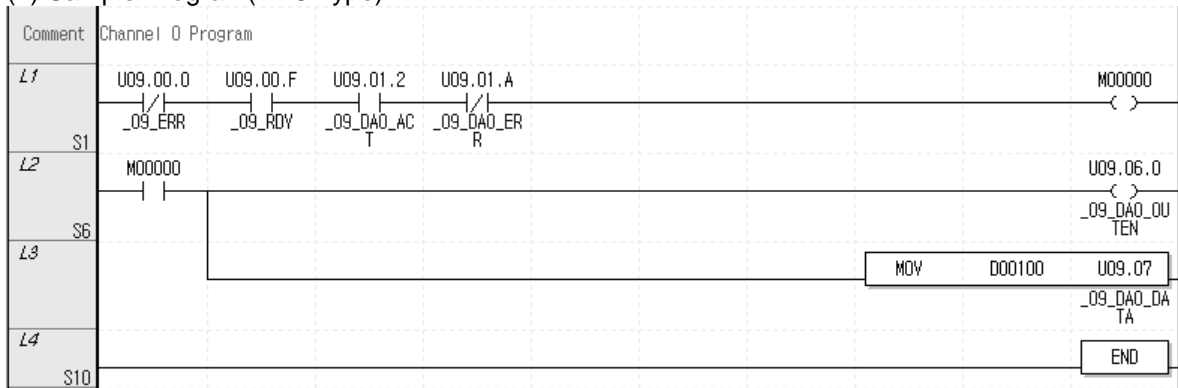

- (a) When the option board is in normal operation, M0000 is turned On.  
 U09.00.0 (Module Error) = Off  
 U09.00.F (Module Ready) = On  
 U09.01.2 (Output Channel 0 in-operation) = On  
 U09.01.A (Output Channel 0 Error) = Off
- (b) When M0000 is ON, it turns on CH0 output state (U09.06.0) and allows output
- (c) When M0000 is ON, D00100 data is moved to output CH0 Output value (U09.07) and outputs.

(3) Sample Program/(IEC Type)

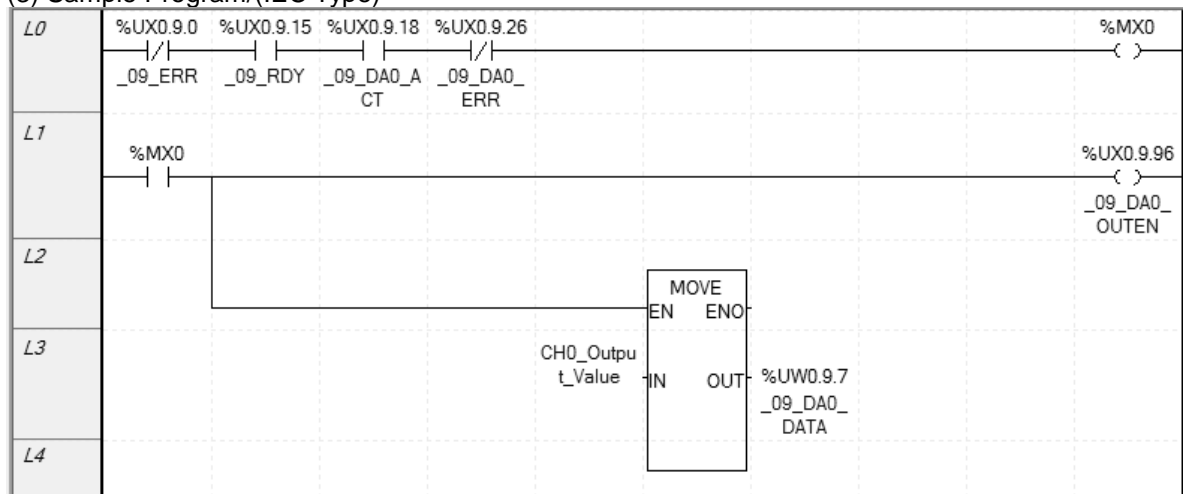

- (a) When the option board is in normal operation, %MX0 is turned On.  
 %UX0.9.0 (Module Error) = Off  
 %UX0.9.15 (Module Ready) = On  
 %UX0.9.18 (Output Channel 0 in-operation) = On  
 %UX0.9.26 (Output Channel 0 Error) = Off
- (b) When M0000 is ON, it turns on CH0 output state (%UX0.9.96) and allows output
- (c) When %MX0 is ON, CH0\_Output\_Value data is moved to output CH0 Output value (%UW0.9.7) and outputs.

## 9.13 Troubleshooting

This section describes methods for identifying the troubles which may occur during the operation of analog output option board, and their solutions.

### 9.13.1 Troubleshooting

(1) Analog output value is abnormal.

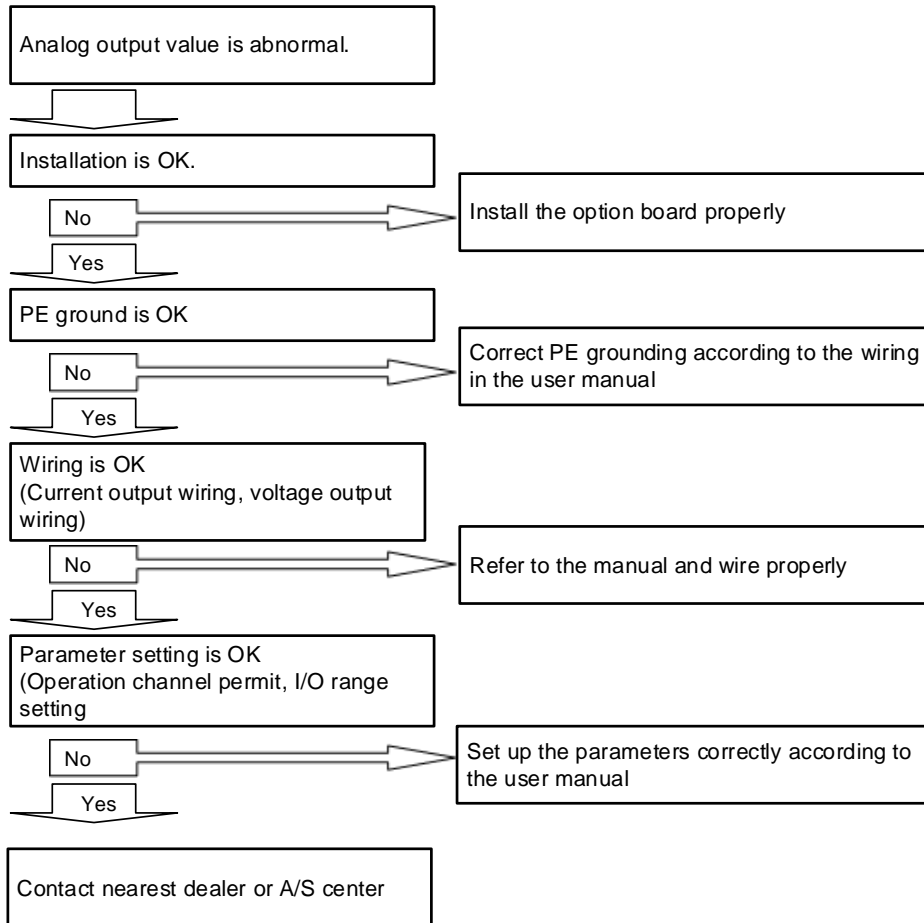

# Chapter 10 Analog I/O Option Board

## 10.1 Setting Sequence before operation

Before using the analog I/O option board, follow steps below.

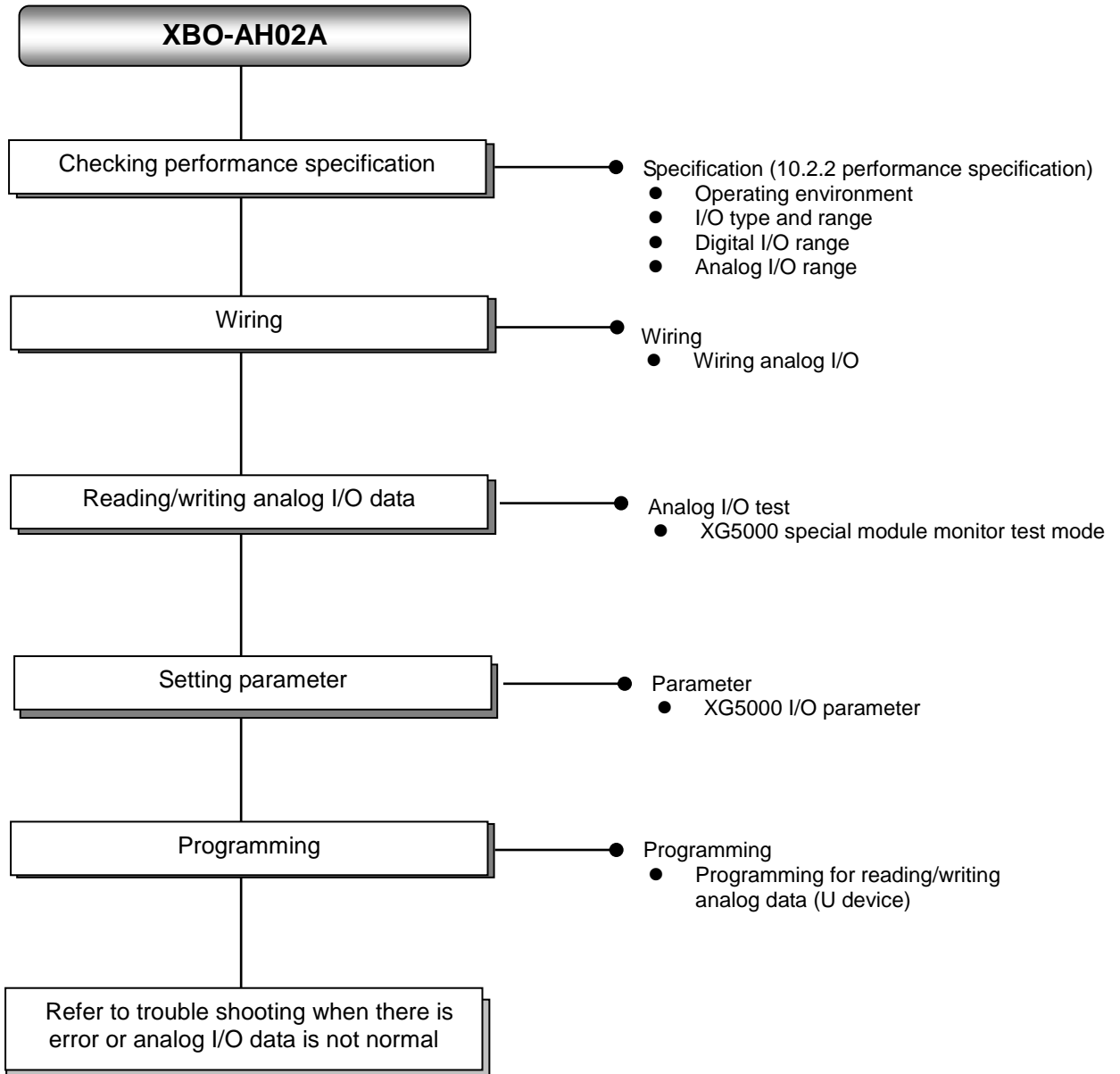

## 10.2 Specifications

### 10.2.1 General specifications

General specifications are as follows.

No.	Item	Specifications	Related specifications			
1	Ambient temperature	0°C ~ +55°C	-			
2	Storage temperature	-25°C ~ +70°C	-			
3	Ambient humidity	5 ~ 95%RH (Non-condensing)	-			
4	Storage humidity	5 ~ 95%RH (Non-condensing)	-			
5	Vibration resistance	Occasional vibration		-	IEC61131-2	
		Frequency	Acceleration	Amplitude		How many times
		5 ≤ f < 8.4 Hz	-	3.5 mm		10 times each directions (X, Y and Z)
		8.4 ≤ f ≤ 150 Hz	9.8 m/s <sup>2</sup> (1G)	-		
		For continuous vibration				
		Frequency	Acceleration	Amplitude		
		5 ≤ f < 8.4 Hz	-	1.75 mm		
8.4 ≤ f ≤ 150 Hz	4.9 m/s <sup>2</sup> (0.5G)	-				
6	Shock resistance	<ul style="list-style-type: none"> <li>Peak acceleration: 147 m/s<sup>2</sup>(15G)</li> <li>Duration: 11ms</li> <li>Half-sine, 3 times each direction per each axis</li> </ul>	IEC61131-2			
7	Noise resistance	Square wave Impulse noise	AC: ± 1,500V DC: ± 900V	LS ELECTRIC standard		
		Electrostatic discharge	Voltage : 4kV (contact discharging)	IEC 61131-2, IEC 61000-4-2		
		Radiated electromagnetic field noise	80 ~ 1,000 MHz, 10V/m	IEC 61131-2, IEC 61000-4-3		
		Fast transient /bust noise	Segment Voltage	Power supply module 2kV	Digital/analog input/output communication interface 1kV	IEC 61131-2, IEC 61000-4-4
8	Environment	Free from corrosive gasses and excessive dust	-			
9	Altitude	Up to 2,000 ms	-			
10	Pollution degree	Less than equal to 2	-			
11	Cooling	Air-cooling	-			

10.2.2 Performance specifications

Performance specifications are as follows.

(1) Input performance specification

Items		Input performance specification		
Number of channels		1 channel		
Analog input range	Type	Voltage	Current	
	Range	DC 0 ~ 10V (Input resistance: 1M $\Omega$ Min.)	DC 4 ~ 20mA DC 0 ~ 20mA (Input resistance: 250 $\Omega$ )	
		Set by external voltage/current wiring after being set at user program or I/O parameter per each channel		
Digital output	Type	12 bit binary data		
	Range	Unsigned value	0 ~ 4000	
		Signed value	-2000 ~ 2000	
		Precise value	0 ~ 1000 (DC 0 ~ 10V)	400 ~ 2000 (DC 4 ~ 20mA) 0 ~ 2000 (DC 0 ~ 20mA)
		Percentile value	0 ~ 1000	
Max. resolution		1/4000 (DC 4~20mA: 1/3200)		
		2.5mV (DC 0~10V)	5 $\mu$ A (DC 0~20mA) 6.25 $\mu$ A (DC 4~20mA)	
Accuracy		$\pm$ 1.0% or less		
Max. conversion speed		1ms/channel + scan time		
Absolute max. input		DC +12V / -10V	DC $\pm$ 25mA	
Additional function	Average function	Count average (2 ~ 64,000 times)		
	Gain adjustment function	Gain adjustment (-40~40)		

## (2) Output performance specification

Items		Output performance specification	
Number of channels		1 channel	
Analog output range	Type	Voltage	Current
	Range	DC 0 ~ 10V (Load resistance: 2k $\Omega$ Min.)	DC 4 ~ 20mA DC 0 ~ 20mA (Load resistance: 450 $\Omega$ Max.)
		Set at user program or I/O parameter per each channel per each channel	
Digital input	Type	12 bit binary data	
	Range	Unsigned value	0 ~ 4000
		Signed value	-2000 ~ 2000
		Precise value	0 ~ 1000 (DC 0 ~ 10V)
Percentile value		0 ~ 1000	
Max. resolution		1/4000 (DC 4 ~ 20mA; 1/3200)	
		2.5mV (DC 0~10V)	5 $\mu$ A (DC 0~20mA) 6.25 $\mu$ A (DC 4~20mA)
Accuracy		$\pm$ 1.0% or less	
Max. conversion speed		1ms/channel + scan time	
Additional function		CH output status setting (select among former, min, middle, max value) Gain adjustment function	

## (3) I/O Common performance specification

Items	I/O common performance specification
Insulation method	Non-insulation between analog I/O channels Non-insulation between I/O terminal and PLC main unit
I/O terminal	5-point terminal block
I/O occupation point	Fixed type: 64 points
Supply power	Internal DC5V
Consumption current	150mA
Weight	20g

Note1) In order to use analog I/O option board, the following version is needed.

Main unit	Version information
XBC E type	V1.1 or above
XBC S type	V1.1 or above
XBC SU type	V1.0 or above
XEC E type	V1.0 or above
XEC SU type	V1.0 or above
XG5000	V.3.61

Note2) Offset/gain value on the analog output range can be adjusted at XG5000- I/O parameter



### 10.3 Name of Part and Function

Respective designations of the parts are as described below.

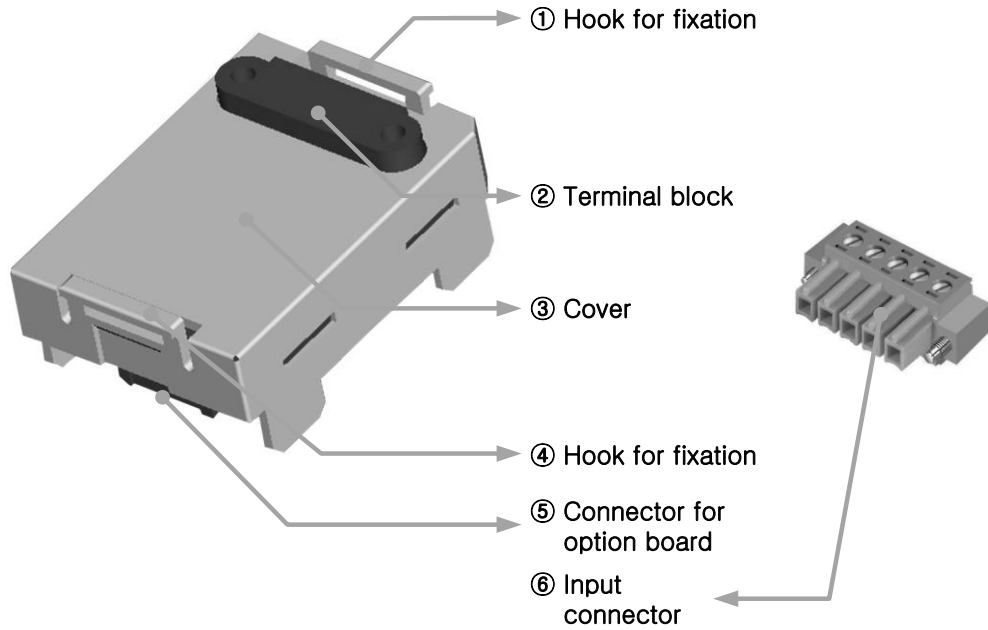

No.	Name	Description
①④	Hook for fixation	▶ Hook for fixing the option board to main unit
②	Terminal block	▶ Wiring terminal block to connect with external device (Analog Input/Output)
③	Cover	▶ Option board cover
⑤	Connector for option board	▶ Connection connector for connecting the option board to the main unit
⑥	Input connector	▶ Wiring connector for connecting with the external device

### 10.4 Characteristic of I/O conversion

The input ranges of voltage and current can be set up per channel with user program or I/O parameters. The output types of digital data are defined as follows.

- (1) Unsigned Value
- (2) Signed Value
- (3) Precise Value
- (4) Percentile Value

#### 10.4.1 Input characteristic

Data conversion characteristic per input range is as follows.

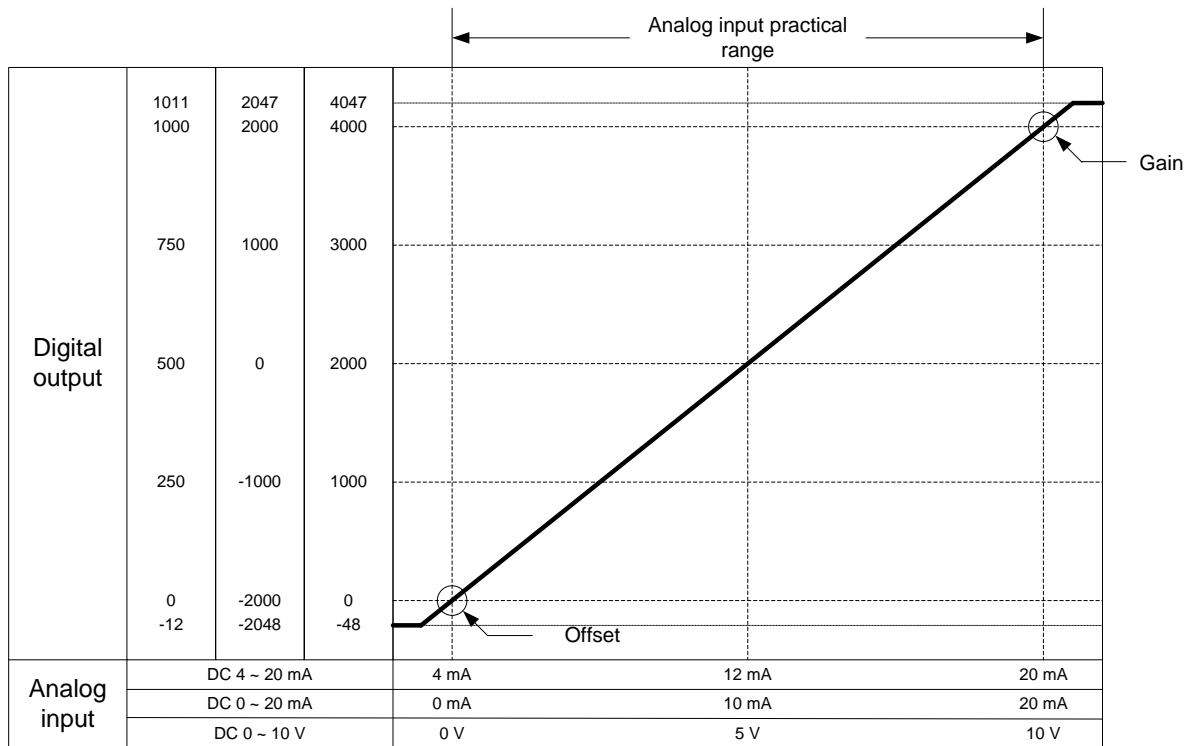

#### (1) DC 4 ~ 20mA Range Input

Digital Output Range	Analog Input Current (mA)						
	3.81	4	8	12	16	20	20.18
Unsigned Value (0 ~ 4000)	-48	0	1000	2000	3000	4000	4047
Signed Value (-2000 ~ 2000)	-2048	-2000	-1000	0	1000	2000	2047
Precise Value (400 ~ 2000)	381	400	800	1200	1600	2000	2018
Percentile Value(0 ~ 1000)	-12	0	250	500	750	1000	1011

(2) DC 0 ~ 20mA Range Input

Digital Output Range	Analog Input Current (mA)						
	-0.24	0	5	10	15	20	20.23
Unsigned Value (0 ~ 4000)	-48	0	1000	2000	3000	4000	4047
Signed Value (-2000 ~ 2000)	-2048	-2000	-1000	0	1000	2000	2047
Precise Value (0 ~ 2000)	-24	0	500	1000	1500	2000	2023
Percentile Value (0 ~ 1000)	-12	0	250	500	750	1000	1011

(3) DC 0 ~ 10V Range Input

Digital Output Range	Analog Input Voltage (V)						
	-0.12	0	2.5	5	7.5	10	10.11
Unsigned Value (0 ~ 4000)	-48	0	1000	2000	3000	4000	4047
Signed Value (-2000 ~ 2000)	-2048	-2000	-1000	0	1000	2000	2047
Precise Value (0 ~ 1000)	-12	0	250	500	750	1000	1011
Percentile Value (0 ~ 1000)	-12	0	250	500	750	1000	1011

### 10.4.2 Output characteristic

Data conversion characteristic per output range is as follows.

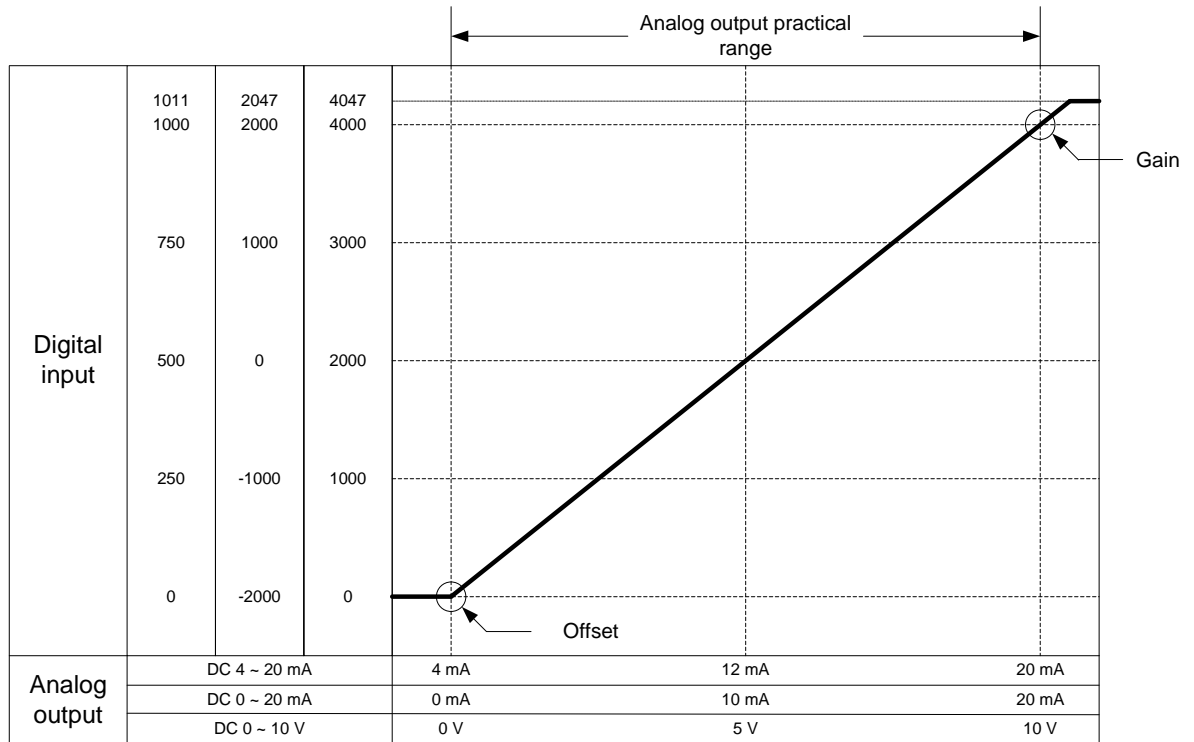

(1) DC 4~20mA range output

Digital input range	Analog output current (mA)						
	4mA or less	4	8	12	16	20	Over 20mA
Unsigned value (0 ~ 4000)	0 or less	0	1000	2000	3000	4000	Over 4000
Signed value (-2000 ~ 2000)	-2000 or less	-2000	-1000	0	1000	2000	Over 2000
Precise value (400 ~ 2000)	400 or less	400	800	1200	1600	2000	Over 2000
Percentile value (0 ~ 1000)	0 or less	0	250	500	750	1000	Over 1000

(2) DC 0 ~ 20mA range output

Digital input range	Analog output current (mA)						
	0mA or less	0	5	10	15	20	Over 20mA
Unsigned value (0 ~ 4000)	0 or less	0	1000	2000	3000	4000	Over 4000
Signed value (-2000 ~ 2000)	-2000 or less	-2000	-1000	0	1000	2000	Over 2000
Precise value (0 ~ 2000)	0 or less	0	500	1000	1500	2000	Over 2000
Percentile value (0 ~ 1000)	0 or less	0	250	500	750	1000	Over 1000

(3) DC 0 ~ 10V range output

Digital input range	Analog output voltage (V)						
	0V or less	0	2.5	5	7.5	10	Over 10V
Unsigned value (0 ~ 4000)	0 or less	0	1000	2000	3000	4000	Over 4000
Signed value (-2000 ~ 2000)	-2000 or less	-2000	-1000	0	1000	2000	Over 2000
Precise value (0 ~ 2000)	0 or less	0	250	500	750	1000	Over 1000
Percentile value (0 ~ 1000)	0 or less	0	250	500	750	1000	Over 1000

**Note**

- (1) There is "Dead Band" area around voltage output (0V), current output (0mA).
  - (a) Digital input-based: about 0 ~ 10
  - (b) Analog output-based: voltage(about 0 ~ 25 mV), current (about 0 ~ 50  $\mu$ A)
- (2) In "Dead Band" area, digital input and analog output may not coincide (within accuracy)

## 10.5 Accuracy

### 10.5.1 Input accuracy

Accuracy of digital output value does not change even if input range is changed. Figure below shows the range of the accuracy with analog input range of 0 ~ 10 V and digital output type of unsigned value selected.

Accuracy of XBO-AH02A is  $\pm 1.0\%$ .

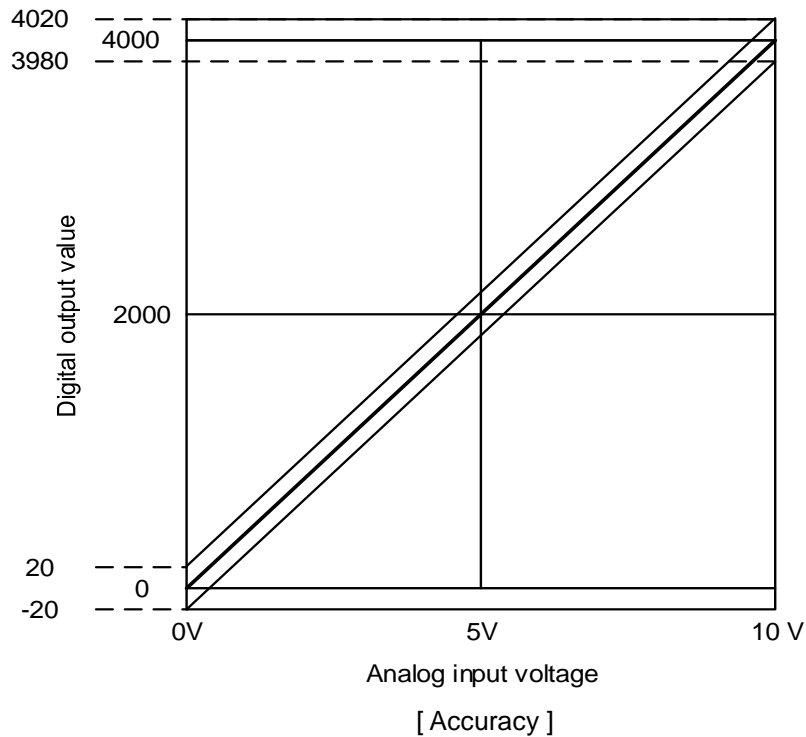

(1) Accuracy when using 5V input

$$4000 \times 1.0\% = 40$$

Therefore the range of the accuracy will become  $(2000-40) \sim (2000+40) = 1960 \sim 2040$  when using 5V input.

(2) Accuracy when using 10V input

$$4000 \times 1.0\% = 40$$

Therefore the range of the accuracy will become  $(4000-40) \sim (4000+40) = 3960 \sim 4040$  when using 10V input.

### 10.5.2 Input accuracy

Accuracy for analog output value does not changed even if output range is changed. Figure below shows the range of the accuracy with analog output range of 0 ~ 10 V and digital output type of unsigned value selected.

Accuracy of XBO-DA02A is  $\pm 1.0\%$ .

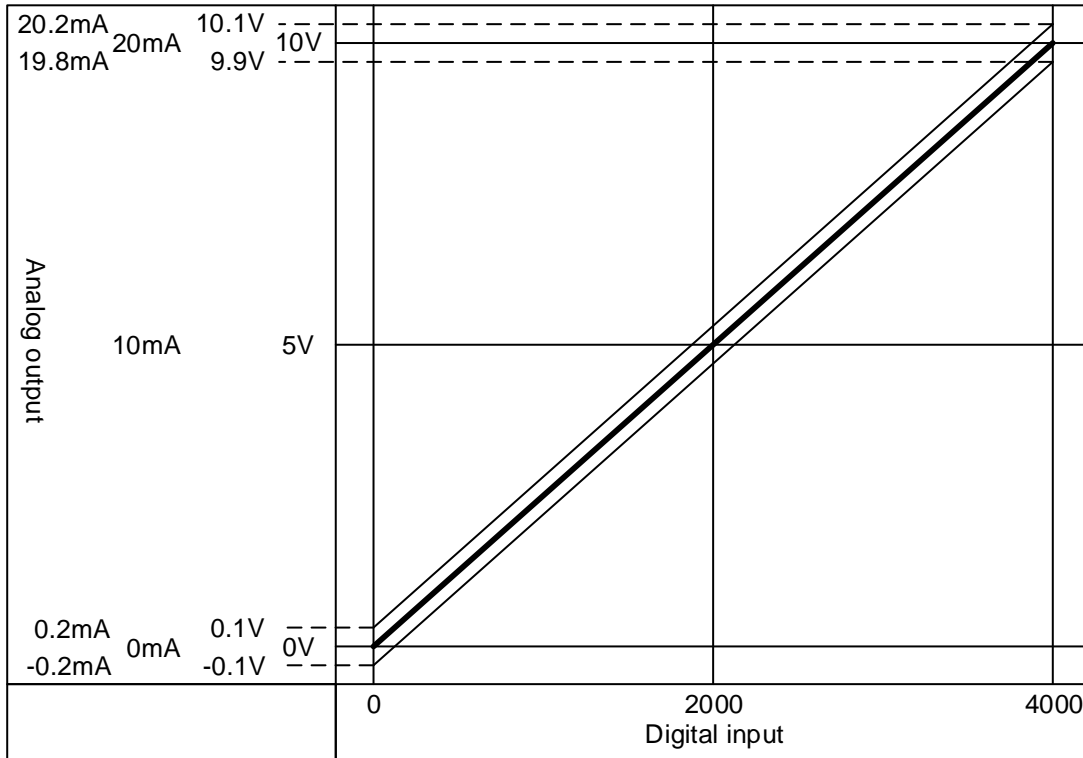

(1) Accuracy in case of 5V output

$$4000 \times 1.0\% = 40$$

So in case of 5V output, accuracy range is

$$(5V - 40 \times 0.0025V) \sim (5V + 40 \times 0.0025V) = 4.9 \sim 5.1V$$

(2) Accuracy in case of 10V

$$4000 \times 1.0\% = 40$$

So in case of 10V output, accuracy range is

$$(10V - 40 \times 0.0025V) \sim (10V + 40 \times 0.0025V) = 9.9 \sim 10.1V$$

## 10.6 Functions of Analog I/O Option Board

The functions of XBO-AH02A analog I/O option board are as follows.

Function	Description
Channel operation/stop setting	<ul style="list-style-type: none"> <li>Specify operation/stop of the channel which will perform A/D, D/A conversion</li> <li>Specifying unused channels as Stop can shorten overall operation time.</li> </ul>
I/O Voltage/current range setting	<ul style="list-style-type: none"> <li>Specify desired range of analog I/O.</li> <li>Select voltage/current with external switch, and set up range with parameter.</li> <li>Analog I/O option board provides 2 ranges(4~20mA, 0~20mA) of current I/O and 1 range ( 0~10V) of voltage I/O.</li> </ul>
I/O data type setting	<ul style="list-style-type: none"> <li>Specify digital I/O types.</li> <li>This option board provides 4 output data types (Unsigned, Signed, Precise, and Percentile Values)</li> </ul>
A/D input conversion method	<ul style="list-style-type: none"> <li>Sampling Process               <ul style="list-style-type: none"> <li>- If A/D conversion method has not been specified, it processes sampling.</li> </ul> </li> <li>Averaging process               <ul style="list-style-type: none"> <li>- Outputs A/D converted value averaged by count to reduce rapid change of input value caused by external noise</li> </ul> </li> </ul>
D/A output status setting	<ul style="list-style-type: none"> <li>When switching form RUN to STOP, it sets output status of channel</li> <li>Provides 4 types of output status (former, min, middle and max value)</li> </ul>

### 10.6.1 Sampling Process

In popular A/D conversion process, analog input signals are collected at constant time intervals and A/D converted. The time elapsed for the analog signals to be converted into digital signals and saved in memory device depends upon the number of channels used.

$$(\text{Process Time}) = (\text{No. of Channels Used}) \times (\text{Conversion Speed} + \text{Scan time})$$

(Ex.) Process time when using 1 of 2 I/O channels and scan time is 2ms;

$$1 \times (1 \text{ ms} + 2 \text{ ms}) = 3 \text{ ms}$$

The term 'sampling' means taking sample value among continuous analog signal values at regular intervals.



### 10.6.2 Count Averaging Function

The input values of the designated channel are accumulated for the preset cycles, and the average value of the total sum is outputted in digital data.

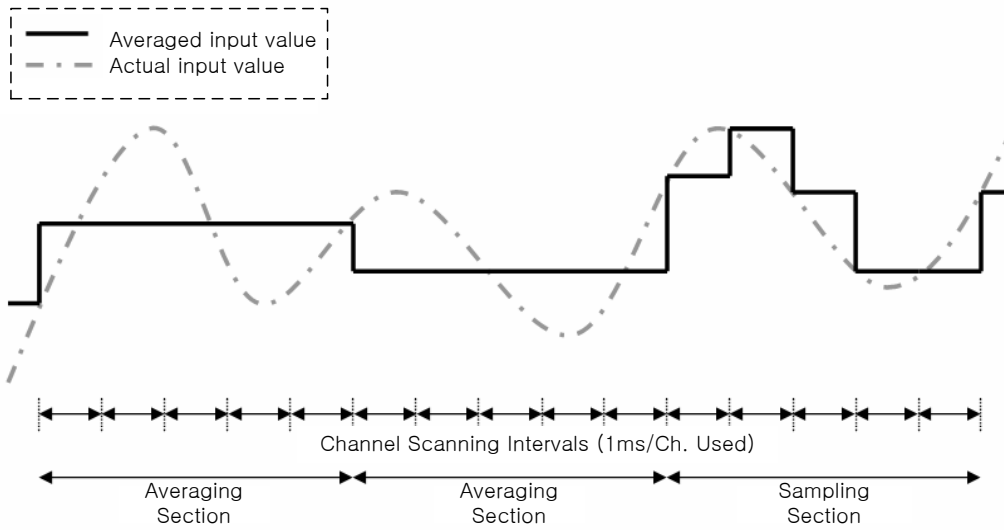

Setting Range = 2 ~ 64000 [times]

For count averaging, averaging interval is calculated with the No. of channels used.

$$\text{Averaging interval [ms]} = \text{Averaging count} \times (\text{No. of channels used} \times 1\text{ms} + \text{Scan time})$$

**Note**

(1) Averaging interval varies according to scan time

### 10.6.3 Channel Output State Setting Function

It sets output against PLC stop and abnormal state

(1) Function

It is used to output an already set value when PLC system switches RUN to Stop

(2) Type

You can select one among former, min, middle and max value.

- (a) Former value: keeps last normal output value
- (b) Min. value: outputs minimum value of the each output range
- (c) Middle value: outputs middle value of the each output range
- (d) Max. value: outputs max. value of the each output range.

(3) Example

When output is 10mA and range of output channel is 4~20mA, if system switches Run to Stop, it outputs as follows according to output state setting.

- (a) Former value: keeps previous output, 10mA
- (b) Min. value: outputs min. value of corresponding range, 4mA.
- (c) Middle value: outputs middle value of corresponding range, 12mA
- (d) Max. value: outputs max. value of corresponding range, 20mA.

### 10.6.4 Gain Adjustment Function

You can adjust I/O gain of the analog I/O option board.

When selecting current input for analog input range, the digital output (4000) corresponding to analog input max. value (20mA) is standard gain value. When selecting voltage input, the digital output (4000) corresponding to analog input max. value (10V) is standard gain value.

- (1) You can adjust input gain at I/O parameter
- (2) I/O gain setting range = - 40 ~ 40
- (3) Adjusting gain for each channel is available

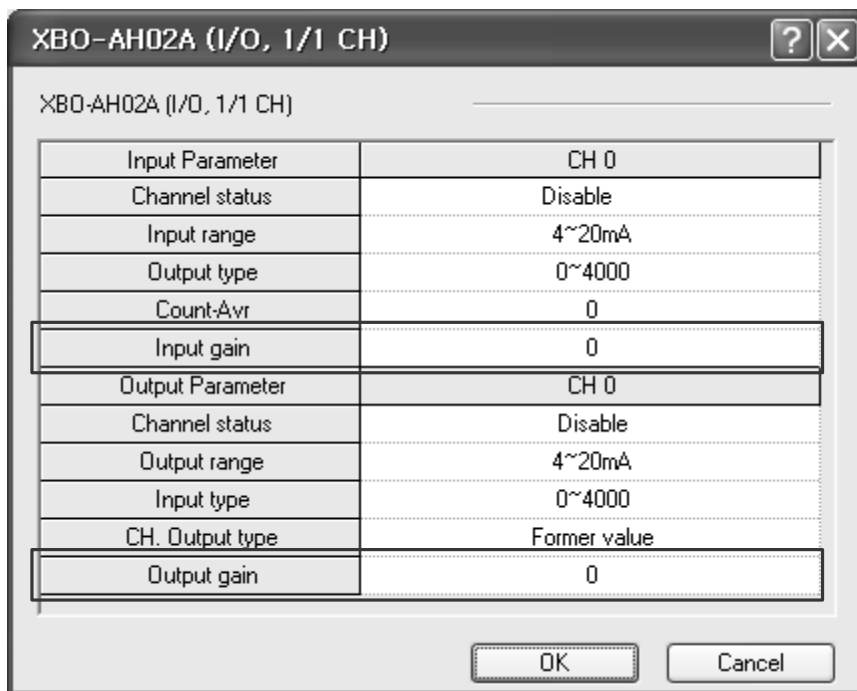

- (4) Example  
When you set "Input gain" as -5, 4005 (=4000-(-5)) applies for gain.

**Note**

- (1) When you adjust the I/O gain, max. resolution changes, too.

## 10.7 Wiring

### 10.7.1 Precaution for wiring

- (1) Don't let AC power line near to A/D conversion module's external input sign line. With an enough distance kept away between, it will be free from surge or inductive noise.
- (2) Cable shall be selected in due consideration of ambient temperature and allowable current, whose size is not less than the max. cable standard of AWG22 (0.3mm<sup>2</sup>).
- (3) Don't let the cable too close to hot device and material or in direct contact with oil for long, which will cause damage or abnormal operation due to short-circuit.
- (4) Check the polarity when wiring the terminal.
- (5) Wiring with high-voltage line or power line may produce inductive hindrance causing abnormal operation or defect.
- (6) Enable only needed channels

### 10.7.2 Terminal block configuration

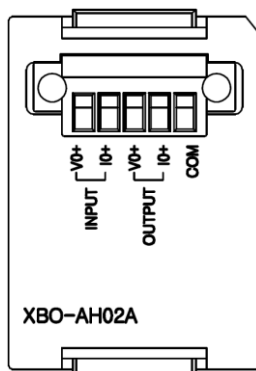

### 10.7.3 Analog input wiring example

(1) Current input wiring example

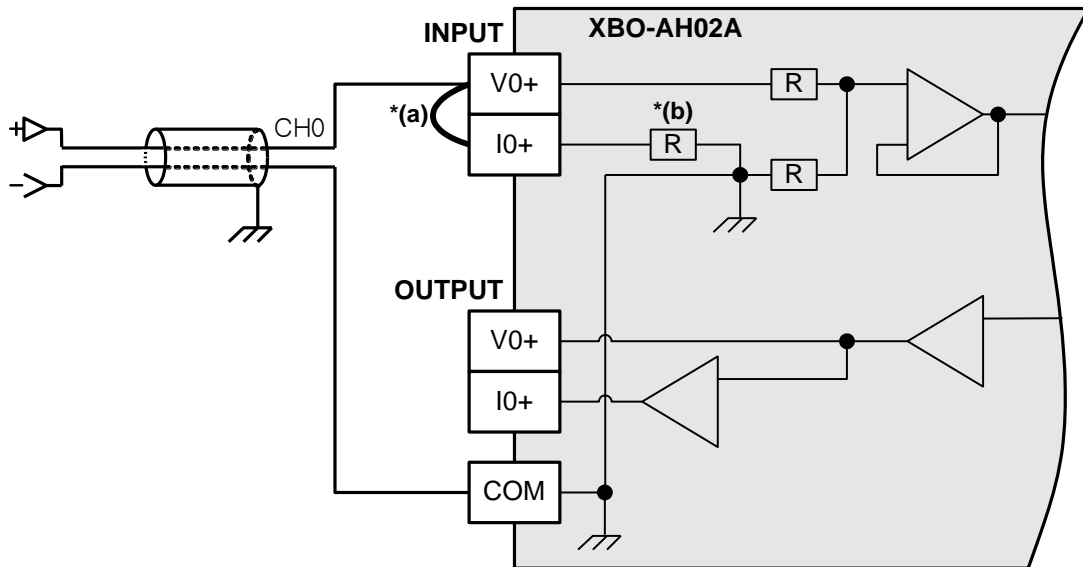

- \*(a) In case of current input, connect V+ terminal to I+ terminal
- \*(b) Input resistance of current input circuit is 250  $\Omega$  (typ.).

(2) Voltage input wiring example

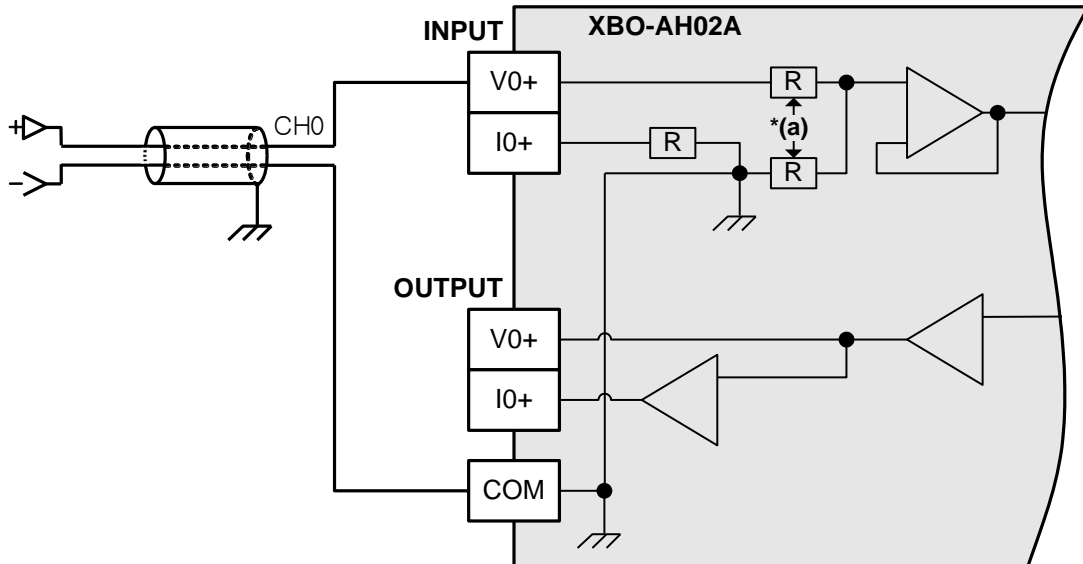

- \*(a) Input resistance of voltage input circuit is 1 M $\Omega$  (min.)

(3) Relationship between voltage input accuracy and wiring length

In voltage input, the wiring (cable) length between transmitter or sensor and option board has an effect on digital-converted values of the option board as specified below;

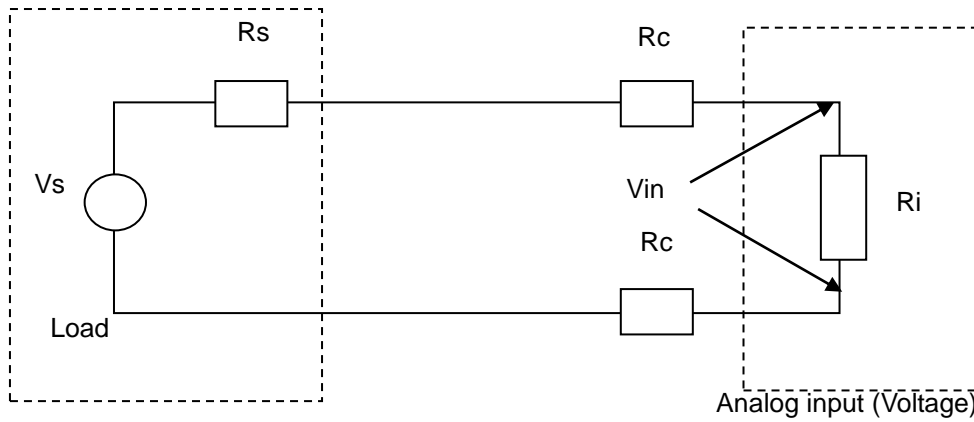

Where,

$R_c$ : Resistance value due to line resistance of cable

$R_s$ : Internal resistance value of transmitter or sensor

$R_i$ : Internal resistance value ( $1M\Omega$ ) of voltage input module

$V_{in}$ : Voltage allowed to analog input module

%  $V_i$ : Tolerance of converted value (%) due to source and cable length in voltage input

$$V_{in} = \frac{R_i \times V_s}{[R_s + (2 \times R_c) + R_i]}$$

$$\% V_i = \left(1 - \frac{V_{in}}{V_s}\right) \times 100\%$$

10.7.4 Analog output wiring example

(1) Current output wiring example

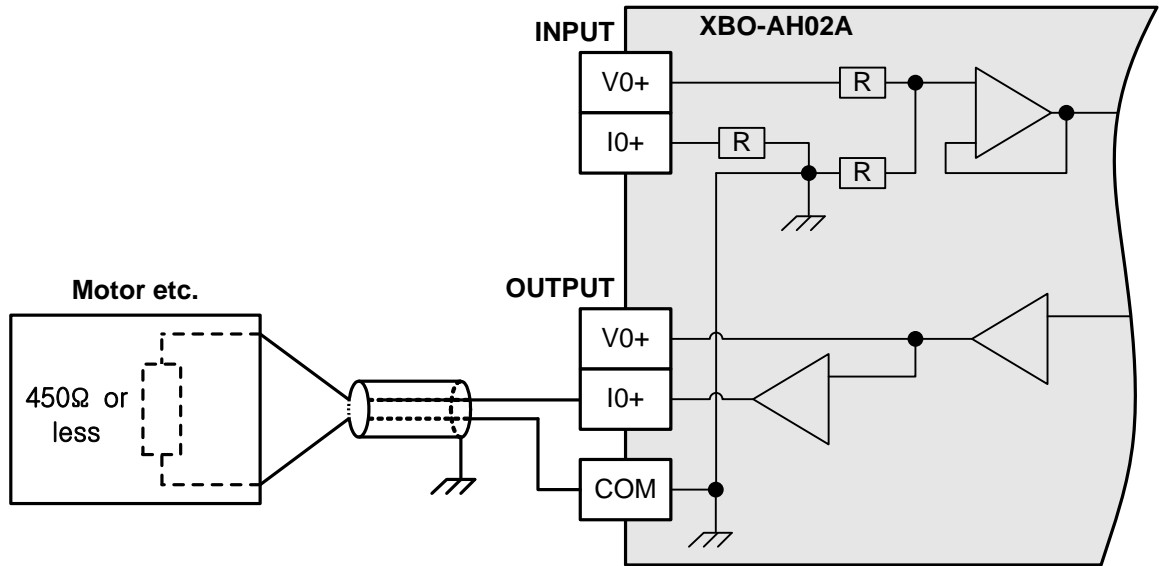

(2) Voltage output wiring example

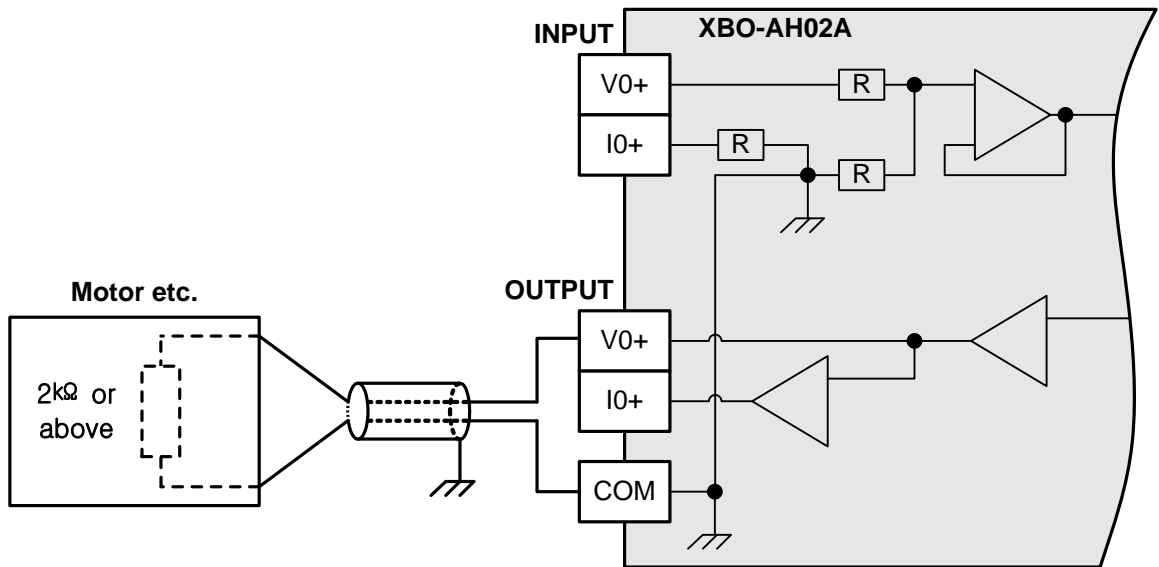

## 10.8 Operation Parameter Setting

Analog I/O option board's operation parameters can be specified through XG5000's [I/O parameters].

### (1) Settings

For the user's convenience, XG5000 provides GUI (Graphical User Interface) for parameters setting of analog option board. Setting items available through [I/O parameters] on the XG5000 project window are as described below in the table.

Item	Details
[I/O parameter]	<p>(a) Input parameter setting Specify the following setting items necessary for the option board operation.</p> <ol style="list-style-type: none"> <li>1) Channel Enable/Disable setting</li> <li>2) Setting ranges of input voltage/current</li> <li>3) Output data format setting</li> <li>4) Count averaging</li> <li>5) Input gain</li> </ol> <p>(b) Output parameter setting Specify the following setting items necessary for the option board operation.</p> <ol style="list-style-type: none"> <li>1) Channel Enable/Disable</li> <li>2) Analog output range (Voltage/current)</li> <li>3) Input data type</li> <li>4) Channel output type</li> <li>5) Output gain</li> </ol> <p>(c) If downloading is complete, Parameter set by user in XG5000 is saved in Flash memory of XGB main unit.</p>

### (2) Usage of [I/O Parameter]

- (a) Create a project with XG5000. See XG5000 Program Manual for project creation.
- (b) In the Project window, double-click [I/O Parameter].

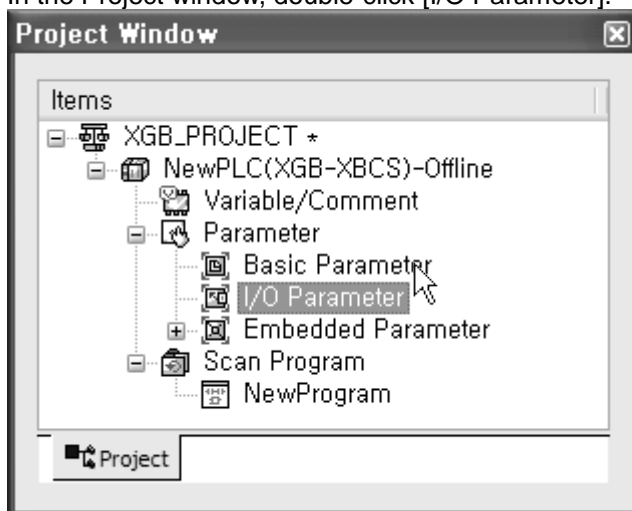



(c) In the [I/O Parameter Setting] window, find out the slot of the base where the analog input option board is installed, and click it.

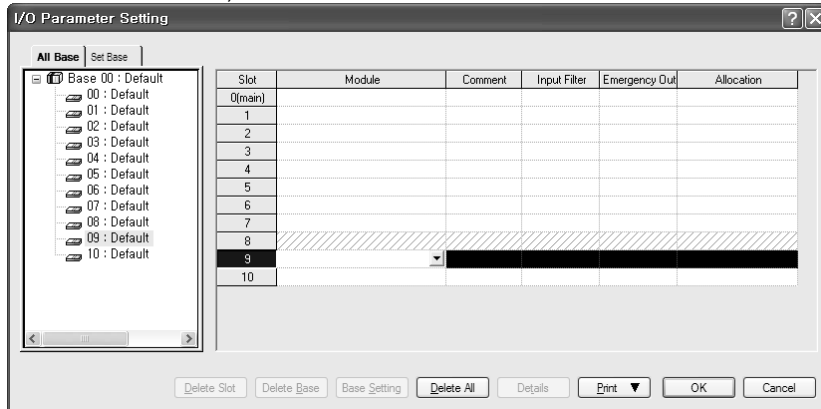

(d) In the above window, click the arrow button to call the window where the module can be selected. Find out the module and select it.

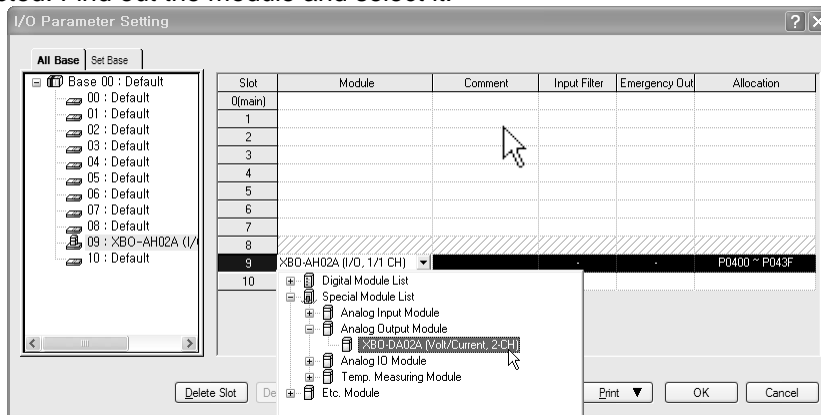

(e) To set up parameter, double click with the respective slot being selected, or click [Detail] button.

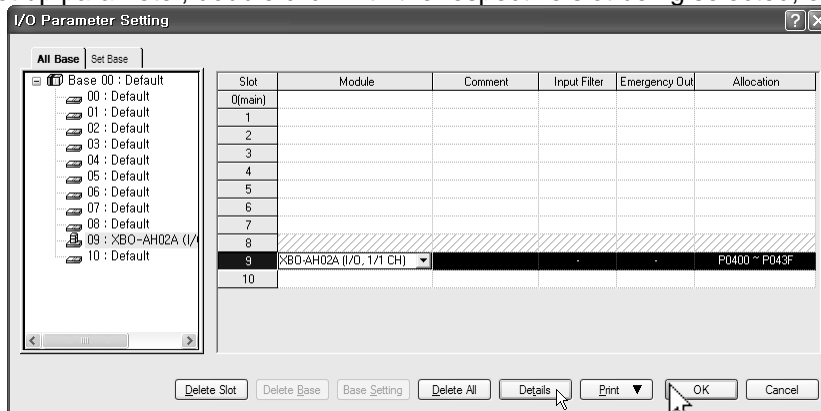

(f) The window below where parameters can be set up by channel appears. Click the item to set up. The parameters which can be set up appear by item.

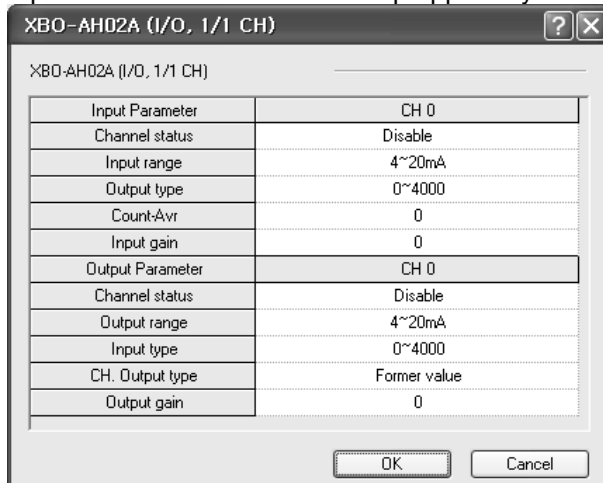

## 10.9 Special Module Monitoring Functions

The functions of the special module monitor are as follows.

(1) Start-up of [Special Module Monitor]

Select [Online] -> [Connect], and [Monitor] -> [Special Module Monitor] to start up. [Special Module Monitor] menu is enabled only in the [Online] condition.

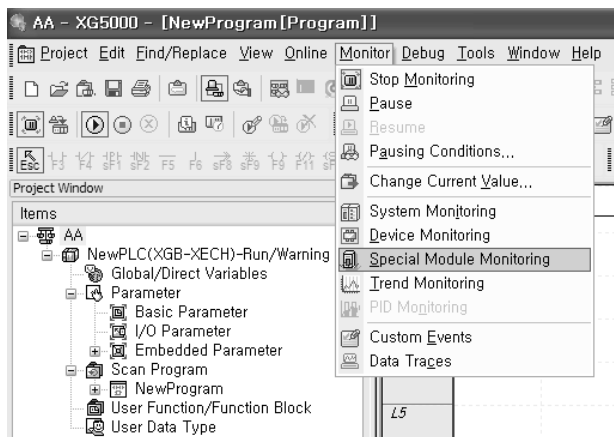

### Note

- 1) The screen may not function properly if the system resources are not sufficient. In this case, close the screen, exit other applications, and rerun XG5000.
- 2) The I/O parameters set up in [Special Module Monitor] condition are temporarily set up for testing purpose. Therefore, these I/O parameters are deleted after exit from [Special Module Monitor].
- 3) The test function of the [Special Module Monitor] enables testing analog input option board without sequence programming.

(2) Usage of [Special Module Monitor]

(a) With the XG5000 in connection (online) with the base unit of PLC, select [Monitor] -> [Special Module Monitor]. The Select Special Module window shown below will appear showing the type of the special modules and base/slot information. In the list dialog, the modules present in the PLC system are displayed.

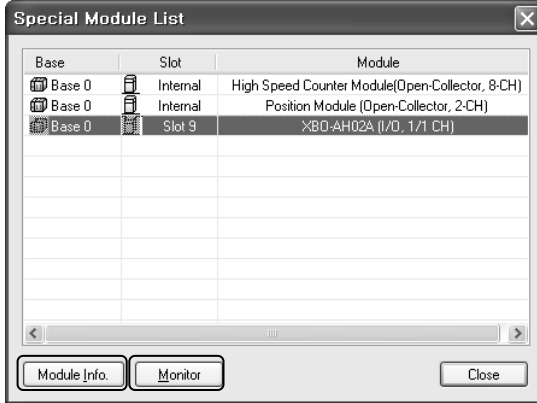

(b) In the above window, select the special module and click [Module Info.] to see the information window below.

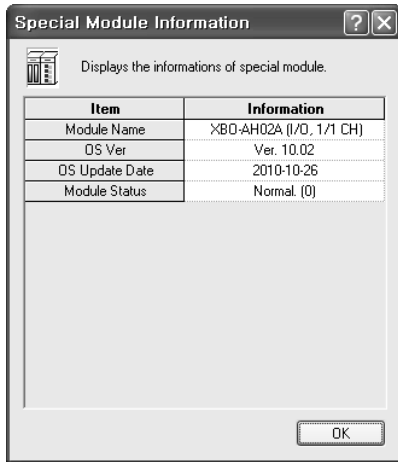

(c) Click the [Monitor] button in the “Special Module” window. The “Special Module Monitor” window will appear as shown below.

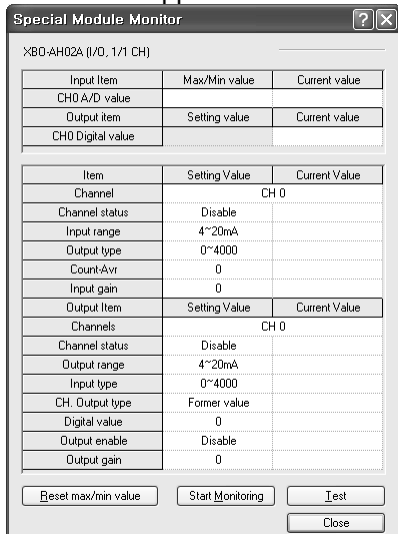

- (d) [Start Monitoring]: click [Start Monitoring] to look up the digital input data of the channel currently in operation. The screen shot below is a monitoring window when all the channels are in operation status.

The screenshot shows the 'Special Module Monitor' window for XBO-AH02A (I/O, 1/1 CH). It contains several tables and callouts:

Input Item	Max/Min value	Current value
CH0 A/D value	3513 / 3512	3513
Output item	Setting value	Current value
CH0 Digital value		3500

Callouts on the right side of the window:

- Input monitoring (points to the Max/Min and Current value columns of the first table)
- Output monitoring (points to the Setting and Current value columns of the second table)
- Detailed information of input CH0 (points to the Input range, Output type, and Input gain rows of the middle table)
- Detailed information of output CH0 (points to the Output range, Input type, CH. Output type, Digital value, Output enable, and Output gain rows of the bottom table)

Buttons at the bottom: Reset max/min value, Stop Monitoring, Test, Close.

The screen executing [Start Monitoring]

- (e) [Test]: this function is used to change the current parameter settings of the analog mix module. Click the settings in the fields in the bottom screen to change the parameters. [Test] can be set up only when the operation status of the XGB base unit is STOP mode.

The screenshot shows the 'Special Module Monitor' window for XBO-AH02A (I/O, 1/1 CH) with parameter settings:

Input Item	Max/Min value	Current value
CH0 A/D value	2226 / 2225	2226
Output item	Setting value	Current value
CH0 Digital value		1750

Item	Setting Value	Current Value
Channel	CH 0	
Channel status	Enable	Enable
Input range	0~10V	0~10V
Output type	0~4000	0~4000
Count-Avr	0	0
Input gain	0	0
Output Item	Setting Value	Current Value
Channels	CH 0	
Channel status	Enable	Enable
Output range	4~20mA	4~20mA
Input type	0~4000	0~4000
CH. Output type	Former value	Former value
Digital value	1750	1750
Output enable	Enable	Enable
Output gain	0	0

The 'Test' button at the bottom is highlighted with a mouse cursor.

Buttons at the bottom: Reset max/min value, Stop Monitoring, Test, Close.

The screen executing [Test]

(f) Minimum/Maximum Value Monitoring

The minimum and maximum values of the input channels in operation can be monitored. However, the Max/Min values in the window are based on the current value. Therefore, the Max/Min values are not saved when exiting from the [Monitoring/Testing Screen].

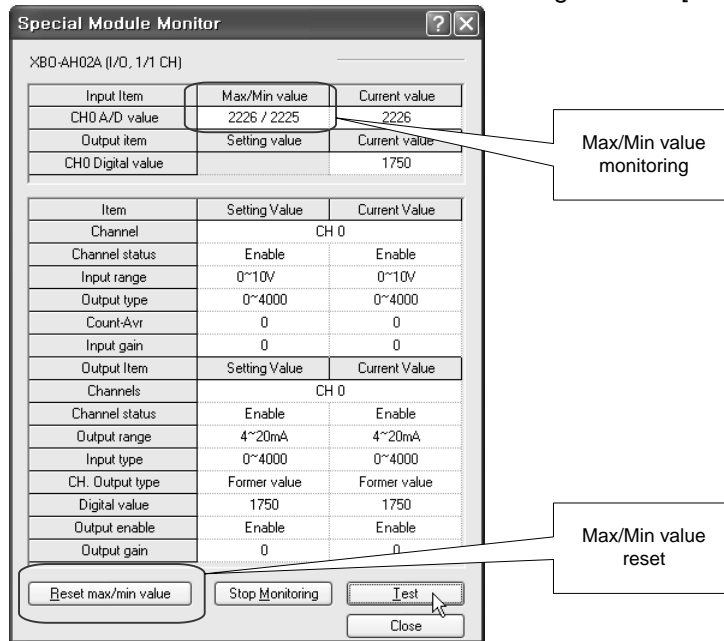

The screen executing [Max/Min Value Monitoring]

(g) Close

[Close] button is for ending/closing the monitoring/testing screen. Maximum, minimum, and current values are not saved at exit.

## 10.10 Register U devices

The variables for each module are automatically registered by referring to the information of the special modules set up in the [I/O Parameter]. User can modify variables and descriptions.

### (1) Registration Procedure

(a) In [I/O Parameter], set up special module in slot.

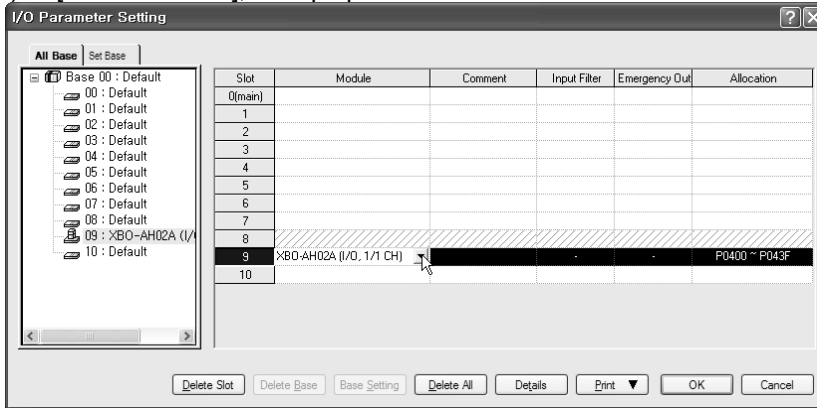

(b) Double click [Variables/Comment].

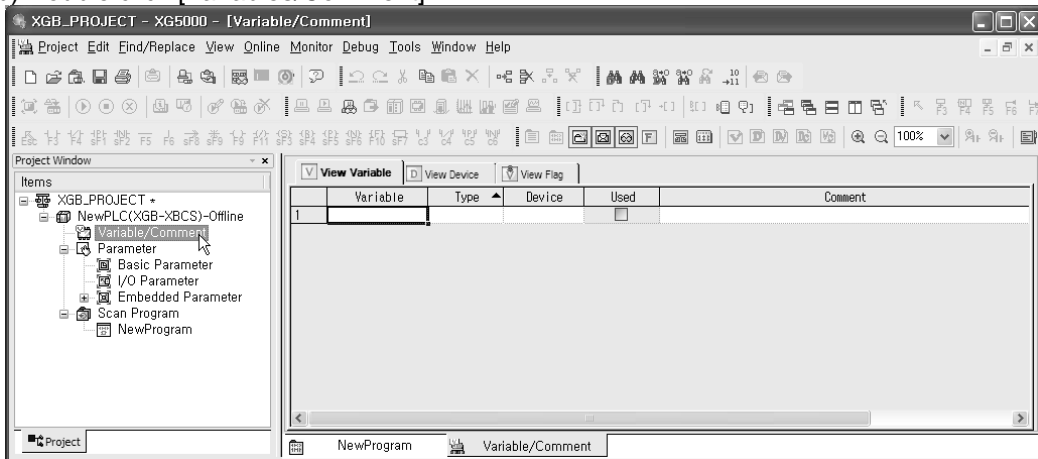

(c) In the 'Edit' menu, select 'Register U device'

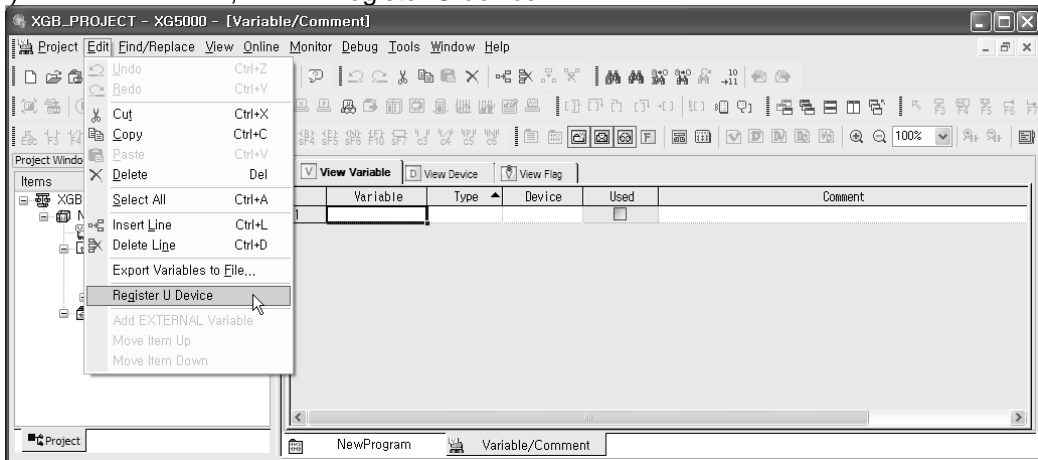

(d) Click 'Yes.'

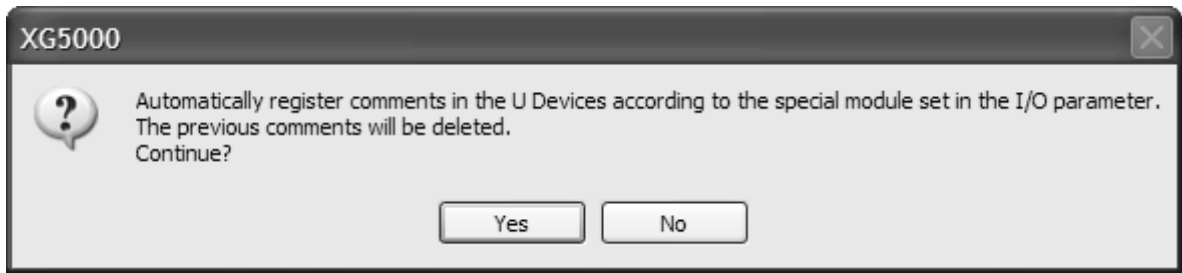

(e) Variables are registered as shown below.

Variable/Comment					
	Variable	Type	Device	Used	Comment
1	_09_ERR	BIT	U09.00.0	<input type="checkbox"/>	Analog I/O Option Board: Error
2	_09_RDY	BIT	U09.00.F	<input type="checkbox"/>	Analog I/O Option Board: Ready
3	_09_ADD_ACT	BIT	U09.01.0	<input type="checkbox"/>	Analog I/O Option Board: Input CHO Active
4	_09_DAO_ACT	BIT	U09.01.2	<input type="checkbox"/>	Analog I/O Option Board: Output CHO Active
5	_09_ADD_IDD	BIT	U09.01.4	<input type="checkbox"/>	Analog I/O Option Board: CHO Input Disconnection Flag
6	_09_ADD_ERR	BIT	U09.01.8	<input type="checkbox"/>	Analog I/O Option Board: Output CHO Error
7	_09_DAO_ERR	BIT	U09.01.A	<input type="checkbox"/>	Analog I/O Option Board: Output CHO Error
8	_09_DAO_OUTEN	BIT	U09.06.0	<input type="checkbox"/>	Analog I/O Option Board: Output CHO Status Setting
9	_09_ADD_DATA	WORD	U09.04	<input type="checkbox"/>	Analog I/O Option Board: Input CHO Data
10	_09_DAO_DATA	WORD	U09.07	<input type="checkbox"/>	Analog I/O Option Board: Output CHO Data

(2) Saving Variables

- (a) The contents in the 'View Variables' tab can be saved in a text file.
- (b) In the 'Edit' menu, select 'Save as Text File.'
- (c) The contents in the 'View Variables' tab are saved in a text file.

(3) Viewing Variables in Program

The figures below present examples of use in XGB compact “E” and “S” types

(a) Below is an exemplary program for XG5000.

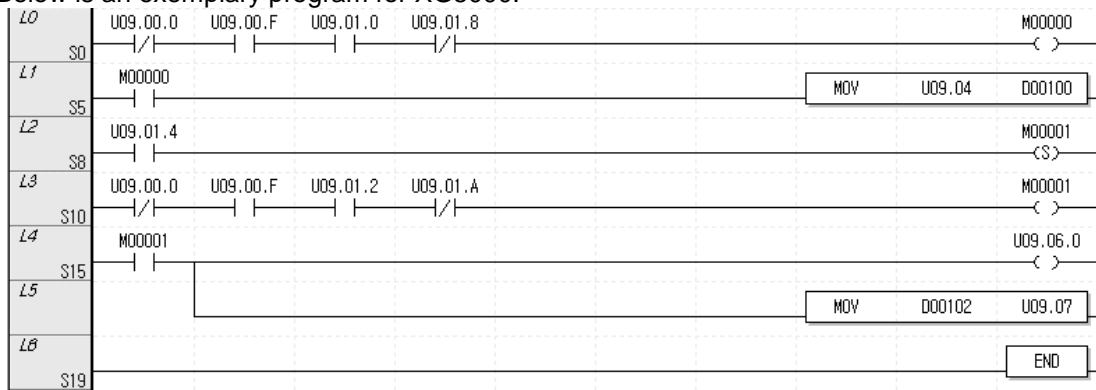

(b) In the ‘View’ menu, click ‘View Variables.’ The devices are changed into variables.

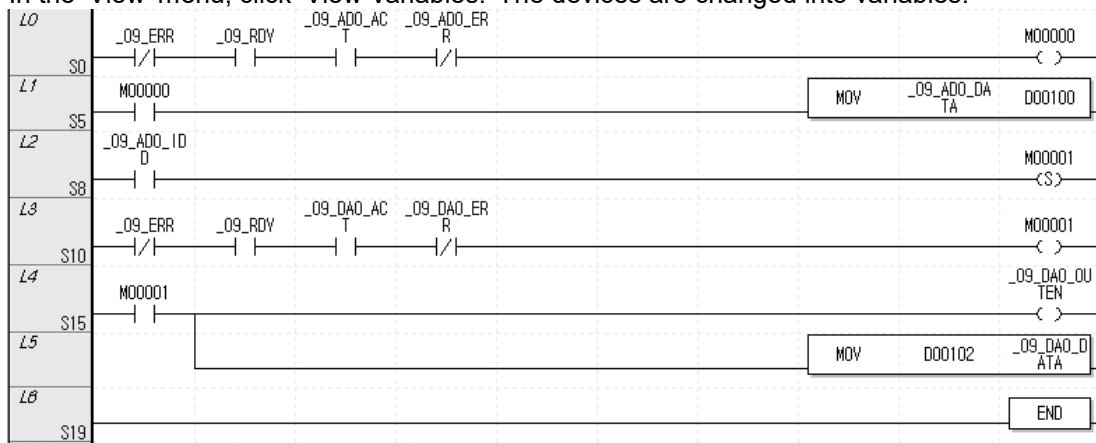

(c) In the ‘View’ menu, click ‘View Device/Variables’ to look up the devices and variables at the same time.

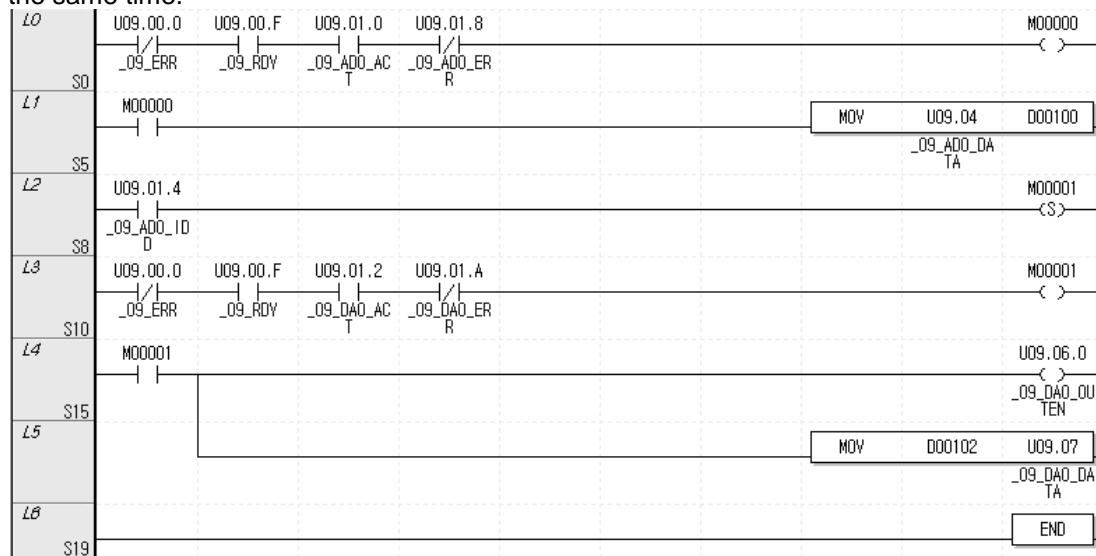



(d) In the 'View' menu, click 'View Device/Comment' to look up the devices and descriptions at the same time.

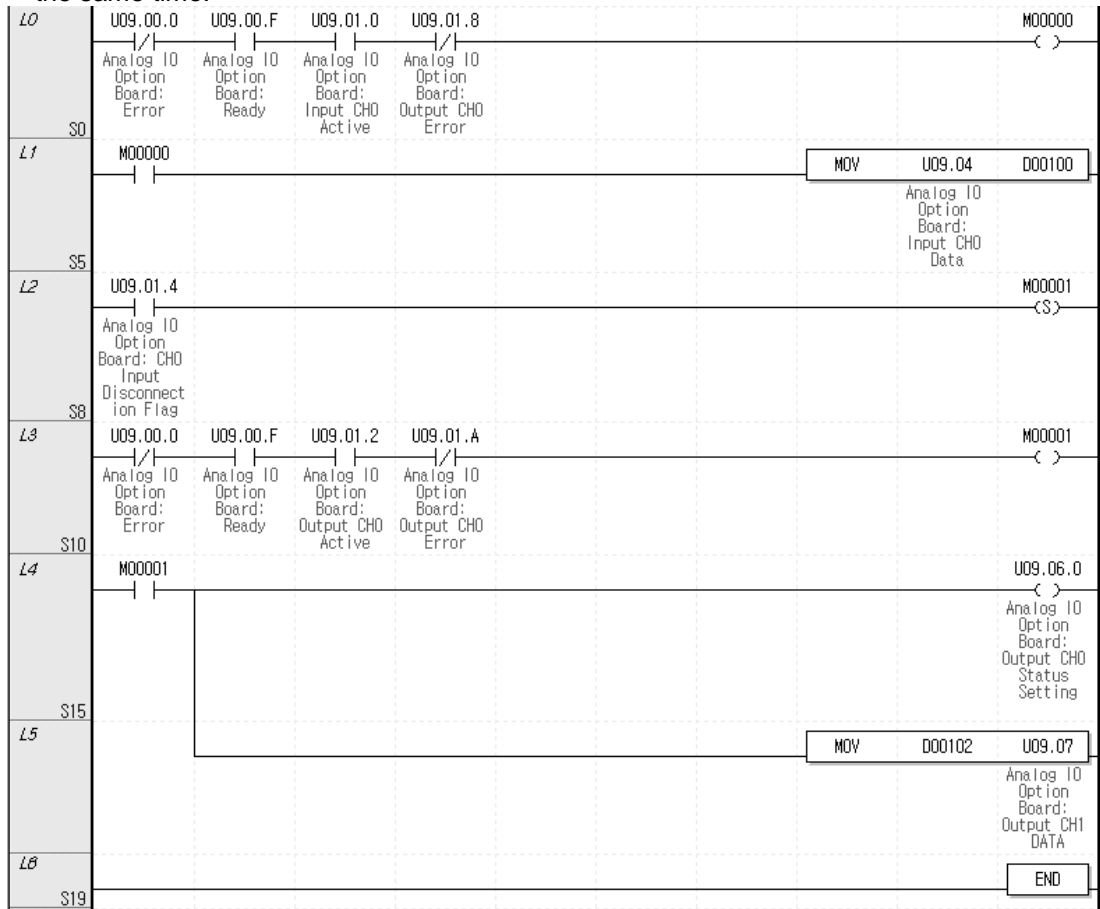

(e) In the 'View' menu, click 'View Variable/Comment' to look up the devices and descriptions at the same time.

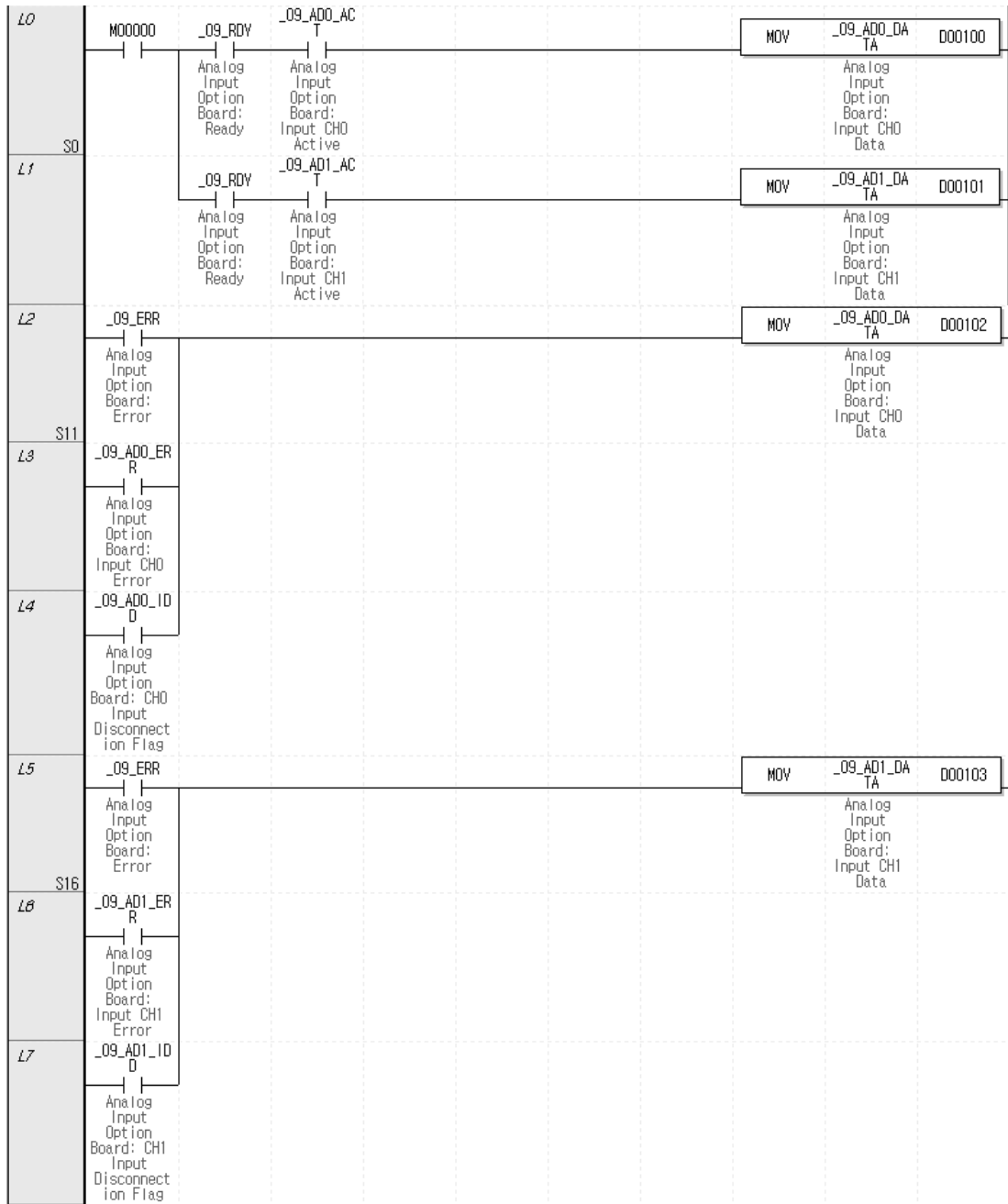

(f) For IEC type also, as shown in Fig. (a) ~ (e), you can look up variables with diversified options in the 'View' menu. The figure below is the case of an IEC type with which the 'View Device/Variables' option.

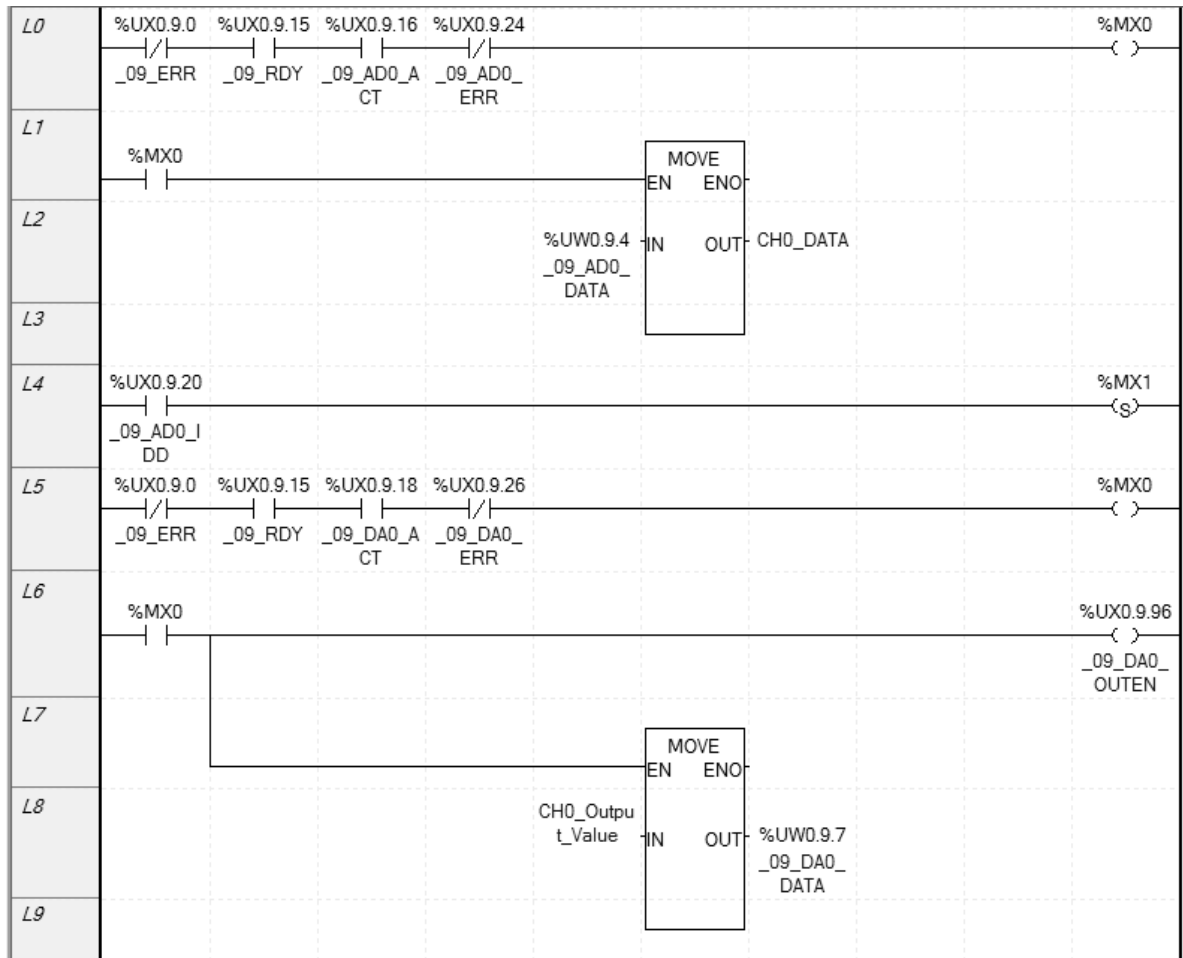

## 10.11 Configuration and Function of Internal Memory

An analog input option board has internal memory for data communication with XGB base unit.

### 10.11.1 Analog Data I/O Area

The table below presents the analog data I/O area.

Variable	Type	Device assignment		Description	R/W	Signal direction
		XBC	IEC			
_0y_ERR	BIT	U0x.00.0	%UX0.0y.0	Module Error	R	Option → CPU
_0y_RDY	BIT	U0x.00.F	%UX0.0y.15	Module Ready		
_0y_AD0_ACT	BIT	U0x.01.0	%UX0.0y.16	Input CH0 Active	R	Option → CPU
_0y_DA0_ACT	BIT	U0x.01.2	%UX0.0y.18	Output CH0 Active		
_0y_AD0_IDD	BIT	U0x.01.4	%UX0.0y.20	Input CH0 Disconnection flag	R	Option → CPU
_0y_AD0_ERR	BIT	U0x.01.8	%UX0.0y.24	Input CH0 error	R	Option → CPU
_0y_DA0_ERR	BIT	U0x.01.A	%UX0.0y.26	Output CH0 error		
_0y_AD0_DATA	WORD	U0x.04	%UW0.0y.4	Input CH0 converted value	R	Option → CPU
_0y_DA0_OUTEN	BIT	U0x.06.0	%UX0.0y.6	CH0 output status setting	W	Option ↔ CPU
_0y_DA0_DATA	WORD	U0x.07	%UW0.0y.7	Output CH0 input value	W	Option ↔ CPU

- In the device allocation, the small letter 'y' is the No. of the slot where the module is installed.
- For example, to read the 'CH0 Input A/D Value' of the analog module installed in the slot 9, write in U09.05. (%UW0.9.4 for IEC types)

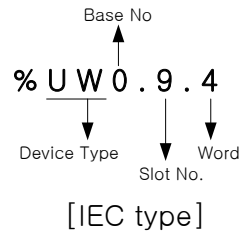
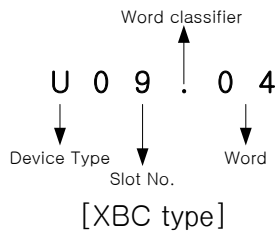

- To read the 'Ch0 Output Value' of the analog I/O module installed in the 9<sup>th</sup> slot, write in U09.07 (%UX0.9.7 for IEC types)

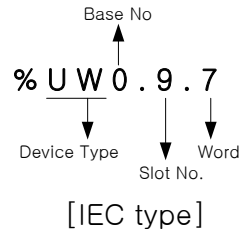
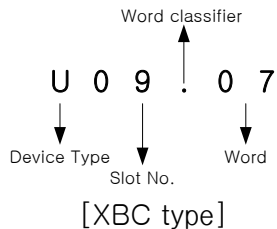

(1) Module Ready/Error Flag ( ) is for IEC types, y: slot No.)

- (a) U0y.00.F(%UX0.y.15): at power on or reset of PLC CPU, turns on when the analog I/O conversion is ready and analog conversion is performed.
- (b) U0y.00.0(%UX0.y.0): the flag indicating the error status of analog input option board module.

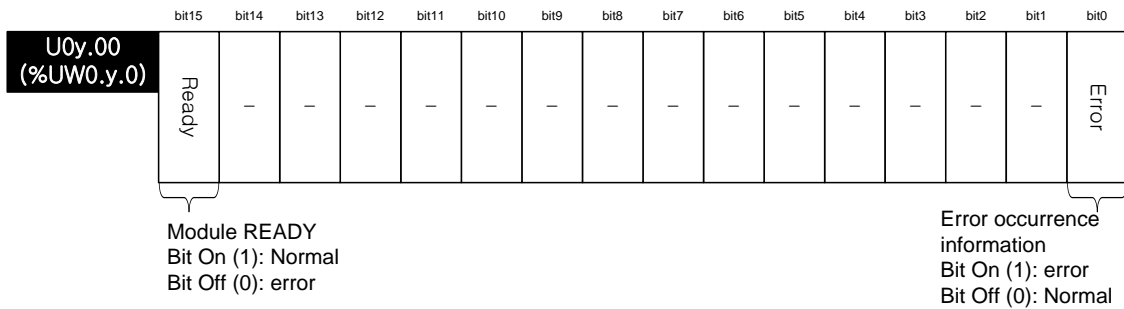

(2) Operation channel information/ channel error information flag ( ) is for IEC types, y: slot No.)

This is the area for storing the operation information and channel error information by channel.

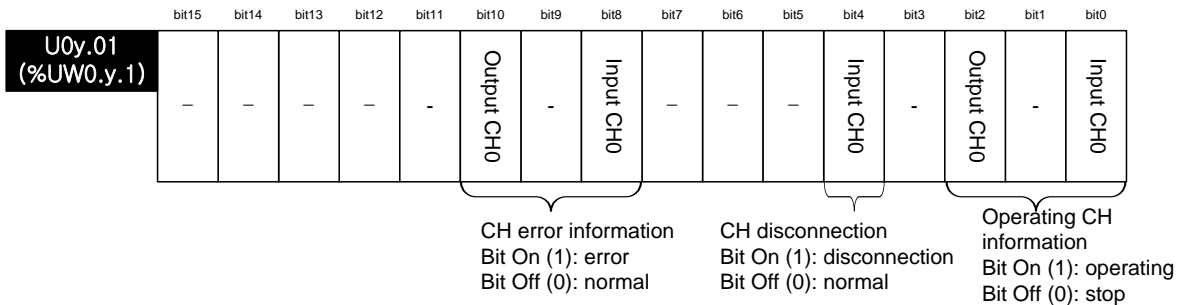

(3) Digital Output Values ( ) is for IEC types, y: slot No.)

- (a) A/D converted digital values are outputted to buffer memory address U0y.04
- (b) Digital output values are saved in 16-bit binary figures.

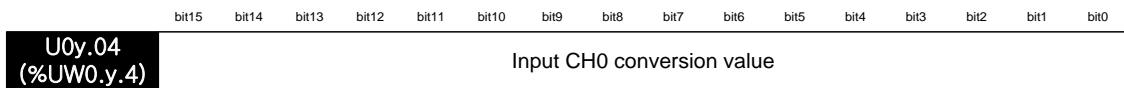

(4) Output setting ( ) is for IEC types, y: slot No.)

- (a) Each channel can be specified enable/disable the analog output.
- (b) If the output is not specified, output of all the channels will be disabled

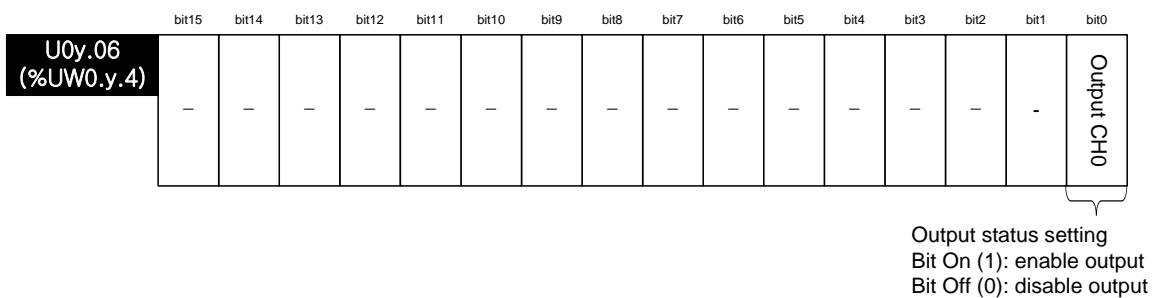

(5) Digital input ( ) is for IEC types, y: slot No.)

- (a) Digital input value can be selected and used within the range of unsigned value (0~4047), signed value (-2000~2047), precise value and percentile value (0~1011) based on input type.
- (b) If the digital input value is not specified, it will be set to 0.

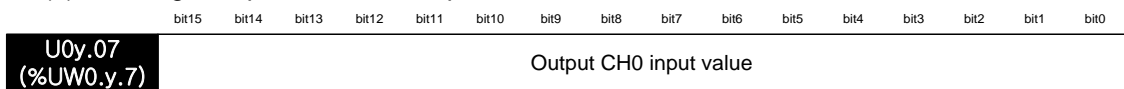

### 10.11.2 Operation Parameter Setting Area

The operation parameter setting area of the analog mix module is as follows.

Memory Add.	Description	Setting	R/W	Command	
0	Enable channel	Bit Off (0): disable, Bit ON (1): enable	R/W	PUT/GET	
1	I/O range setting	Input range setting (4 bit per channels) 0: 4 ~ 20 mA 1: 0 ~ 20 mA 2: 0 ~ 10 V	R/W		
2	I/O data type setting	I/O data type setting (4 bit per channels) 0: 0 ~ 4000 1: -2000 ~ 2000 2: Precise value 3: 0 ~ 1000 - In case of precise value 4 ~ 20 mA: 400 ~ 2000 0 ~ 20 mA: 0 ~ 2000 0 ~ 10 V: 0 ~ 1000	R/W		
3	Input channel 0 count average value setting	0 or 2 ~ 64000 [times]	R/W		
8	CH output state setting	CH output state setting (4bit per channel) 0: Former value 1: min value 2: middle value 3: max value	R/W		
9	Input channel 0 gain weighting	-40~40	R/W		
11	Output channel 0 gain weighting		R/W		
13	Setup error information	100: input ch range setting error 200: input ch data type setting error 300: input ch average value setting error 400: input ch gain weighting setting error 500: output ch range setting error 600: output ch data type setting error 700: output ch output state setting error 800: output ch gain weighting setting error 900: output ch input value excess error	R		GET

- (1) Operating Channel Setting (address 0)
  - (a) You can set "Enable/Disable" of analog I/O option board per each channel
  - (b) Disable the unused channels to reduce the conversion period.
  - (c) Default value is "Disable" for all channels
  - (d) When using PUT instruction, address is as follows.

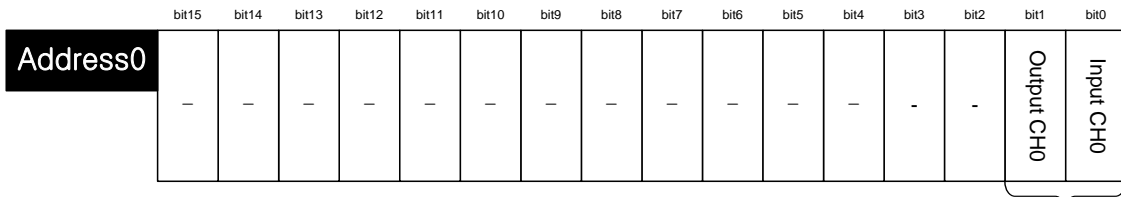

Enable CH  
 Bit On (1): enable  
 Bit Off (0): disable

- (e) The values set in bit 2~15 are ignored.
- (f) This area is same as setting in "Channel status" of I/O parameter

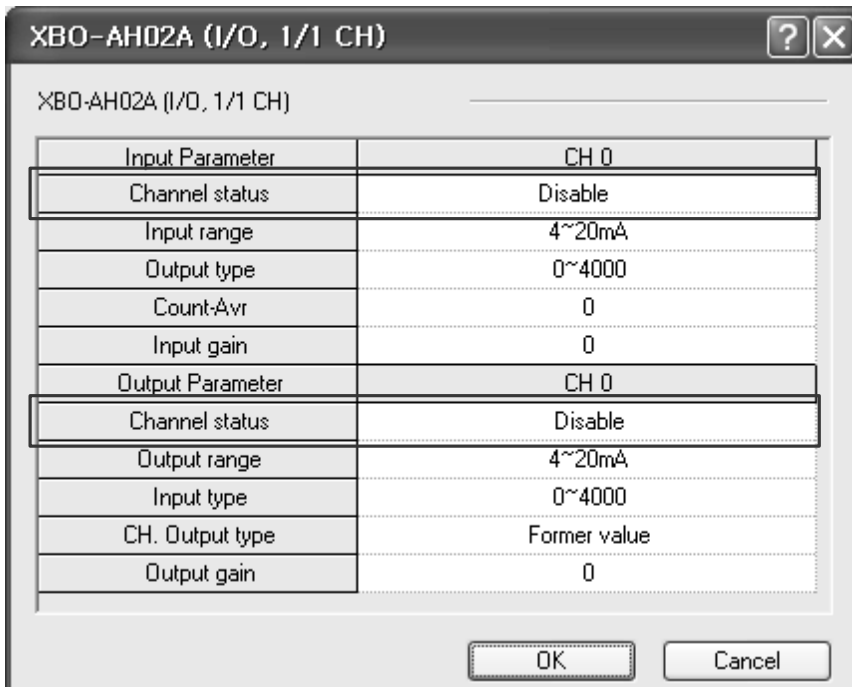

- (2) I/O range setting area (address 1)  
 (a) Set the type of I/O range with the following code

Bit (HEX)	I/O range
0000 (0)	4 ~ 20 mA
0001 (1)	0 ~ 20 mA
0010 (2)	0 ~ 10 V

- (b) If you set more than 3, 0 (4~20mA) will be set forcibly  
 But, U0X.01.8~ U0X.01.A (Setup error flag) will be ON.  
 (c) When using PUT instruction, address is as follows.

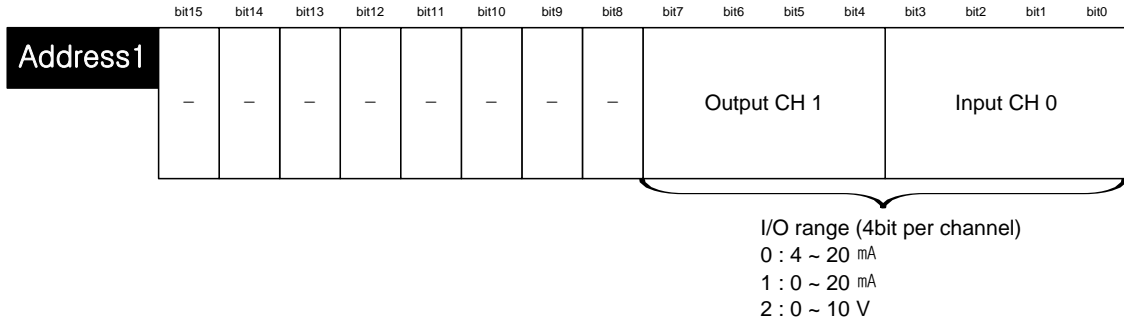

- (d) The values set in bit 8~15 are ignored.  
 (e) This area is same as setting in "Input range" of I/O parameter

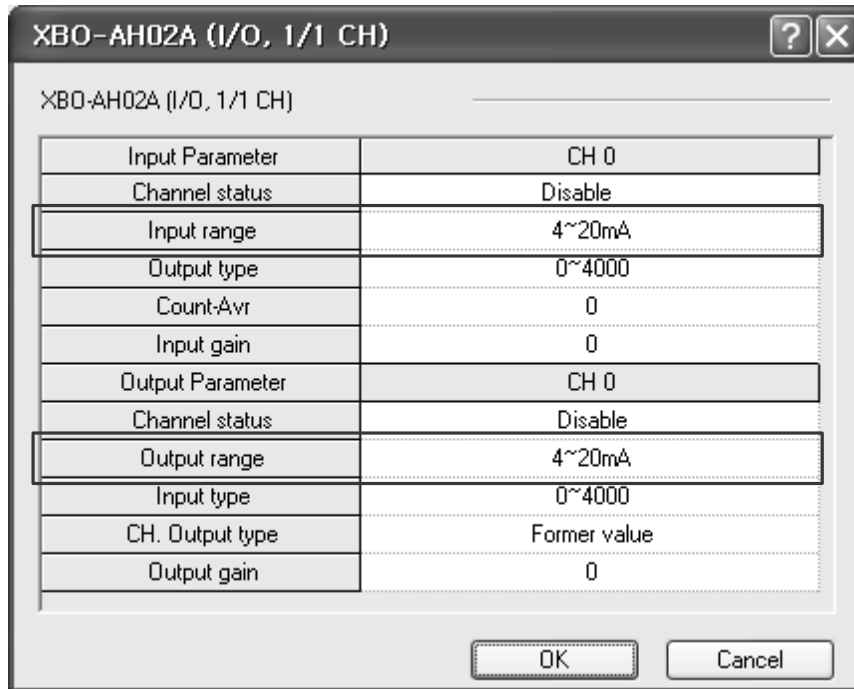



- (3) I/O data type setting area (address 2)
  - (a) Set the type of I/O data type with the following code

Bit (HEX)	Output data type
0000 (0)	0~4000
0001 (1)	-2000~2000
0010 (2)	Precise value
0011 (3)	0~1000

In case of precise value, I/O data type is designated as the following value according to each I/O range type

I/O range	Precise value
4 ~ 20 mA	400 ~ 2000
0 ~ 20 mA	0 ~ 2000
0 ~ 10 V	0 ~ 1000

- (b) If you set more than 4, 0 (0~4000) will be set forcibly.  
But, U0X.01.8~ U0X.01.A (Setup error flag) will be ON.
- (c) When using PUT instruction, address is as follows

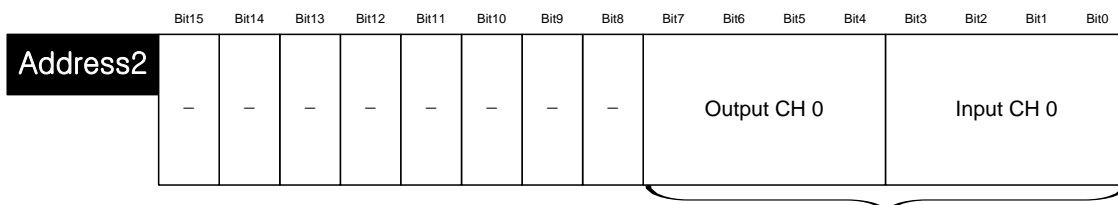

I/O data type (4bit per channel)  
 0 : 0 ~ 4000  
 1 : -2000 ~ 2000  
 2 : precise value  
 3 : 0 ~ 1000

- In case of precise value  
 4 ~ 20 mA: 400 ~ 2000  
 0 ~ 20 mA: 0 ~ 2000  
 0 ~ 10 V: 0 ~ 1000

- (d) The values set in bit 8~15 are ignored.
- (e) This area is same as setting in "Output type" of I/O parameter

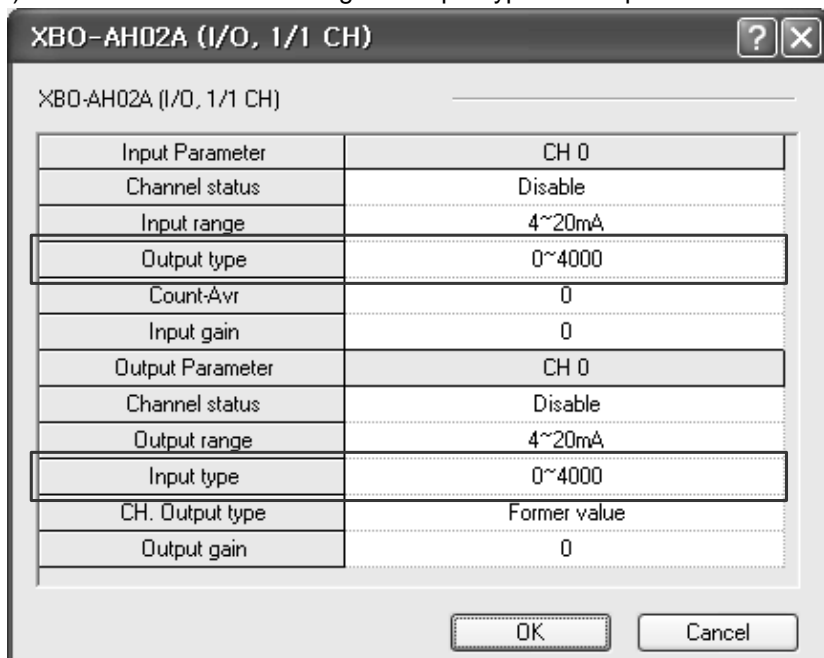

- (4) Count average value setting area (address 3)
  - (a) Set count average value with 0 or value of 2~6400
  - (b) If you set the count average value as 0, corresponding channel will not perform averaging process and output sampled analog input value
  - (c) If you set 1 or more than 64001, 0 (Disable averaging) will be set forcibly.  
But, U0X.01.8 (Setup error flag) will be ON.
  - (d) When using PUT instruction, address is as follows

bit15	bit14	bit13	bit12	bit11	bit10	bit9	bit8	bit7	bit6	bit5	bit4	bit3	bit2	bit1	bit0
<b>Address3</b>															
Input CH0 count average value (0 or 2 ~ 64000 [times])															

- (e) This area is same as setting in “Count-Avr” of I/O parameter

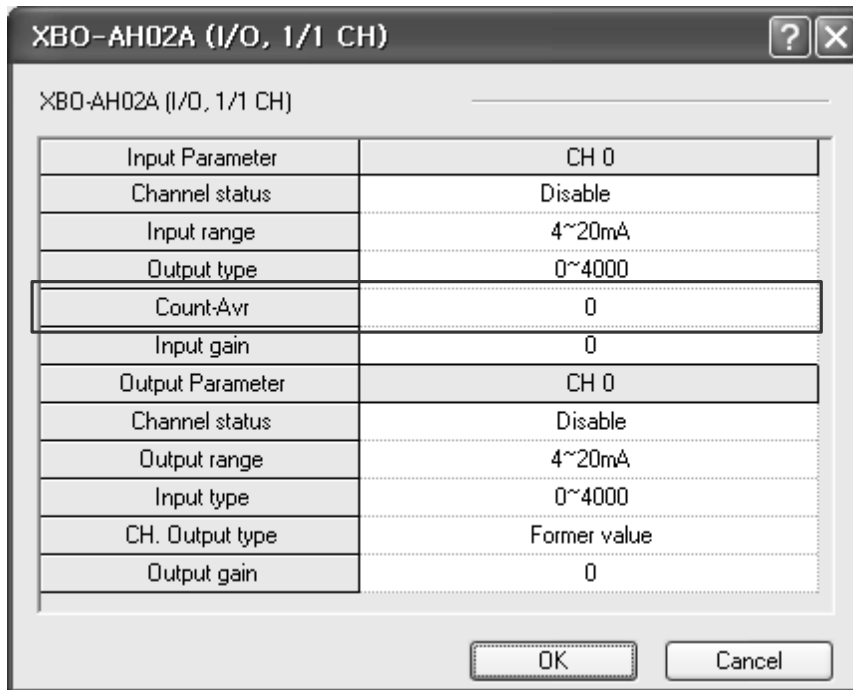

- (5) Channel output state setting area (address 8)
  - (a) Set the output state setting with the following code

Bit (Hex)	Channel output state
0000 (0)	Former value
0001 (1)	Min value
0010 (2)	Middle value
0011 (3)	Max value

- (b) If you set more than 4, 0 (former value) will be set forcibly.  
But, U0X.01.A (Setup error flag) will be ON.
- (c) When using PUT instruction, address is as follows

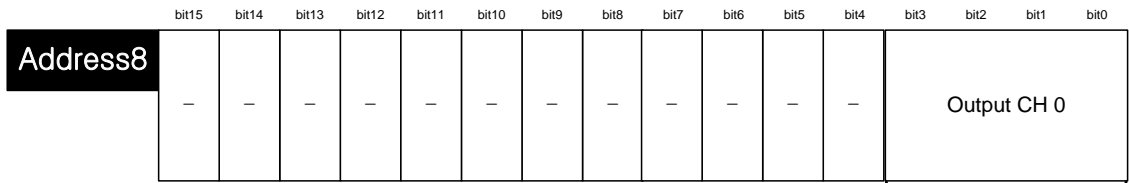

Output CH state setting( 4 bit)  
 0 : Former value  
 1 : min value  
 2 : middle value  
 3 : max value

- (d) The values set in bit 8~15 are ignored.
- (e) This area is same as setting in "CH. Output type" of I/O parameter

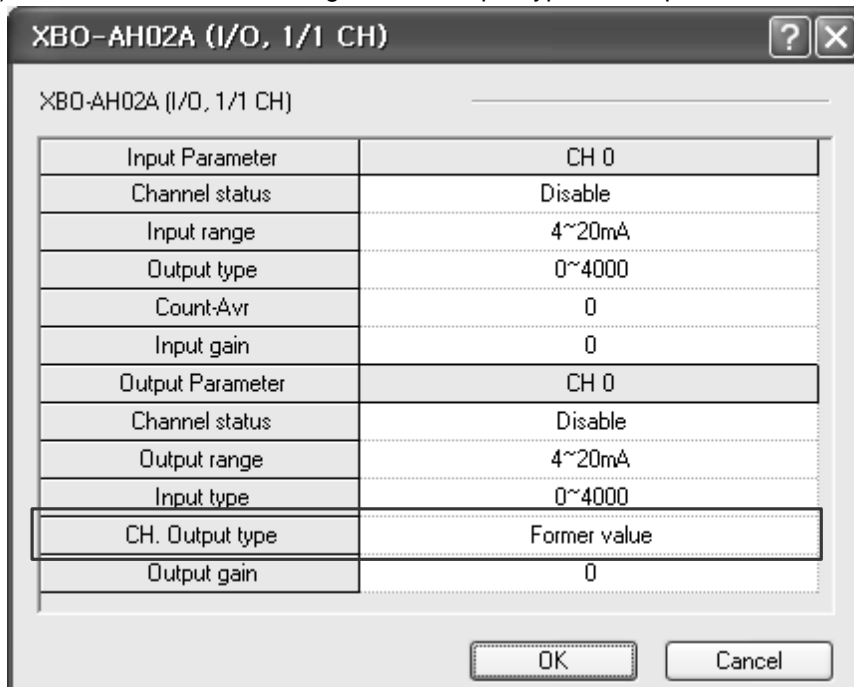

- (6) I/O gain weighting setting area (address 9~11)
  - (a) Set input gain weighting with value of -40~40
  - (b) If you set this as 0 (default value),
    - 4000 will apply for input gain value
    - 4000 will apply for output gain value
  - (c) For example, if you set this as -10, 4010 (=4000-(-10)) will apply for gain value
  - (d) When using PUT instruction, address is as follows

bit15	bit14	bit13	bit12	bit11	bit10	bit9	bit8	bit7	bit6	bit5	bit4	bit3	bit2	bit1	bit0
<b>Address9</b>															
Input CH0 gain (-40 ~ 40)															
<b>Address11</b>															
Output CH0 gain (-40 ~ 40)															

(e) This area is same as setting in "I/O gain" of I/O parameter

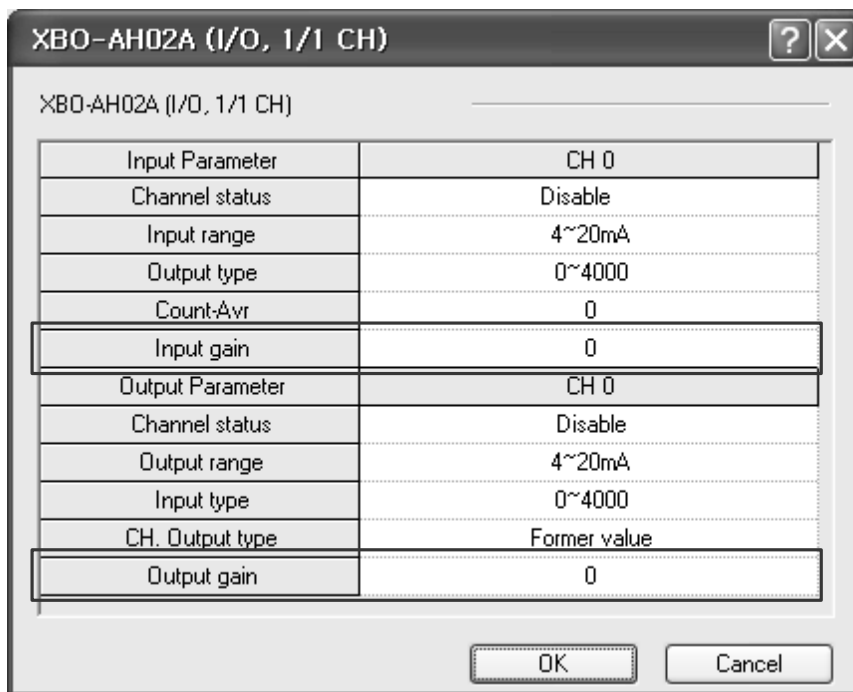

- (6) Setup error information output area (address 13)
  - (a) Saves error code detected when setting (setting by program)
  - (b) Setting error is canceled when value is reset to make it in the valid range
  - (c) When U0X.01.8~ U0X.01.A (setting error flat) is on, check that area and fix the corresponding setting to cancel the error
  - (d) When using GET instruction, address is as follows



Type	Error code	Description	Priority	Remark
Input error	100	Input CH range setting error	2	-
	200	Input CH data type setting error	3	
	300	Input CH count average value setting error	4	
	400	Input CH gain weighting setting error	5	
Output error	500	Output CH range setting error	6	
	600	Output CH data type setting error	7	
	700	Output CH state setting error	8	
	800	Output CH gain weighting setting error	9	
	900	Output CH input value excess error	1	

- (e) When more than two errors occur simultaneously, it saves error code having higher priority.

## 10.12 Example Program

- (1) This sample program sets up operating parameters of analog input option board.
- (2) Initial settings are saved in the internal memory of the XGB main unit by one input.
- (3) The sample program below controls the I/O data of the analog I/O option board at option slot #0 (I/O slot #9) and check open wire.

### 10.12.1 Example of [I/O Parameter] Usage

(1) I/O Parameter Setting Window

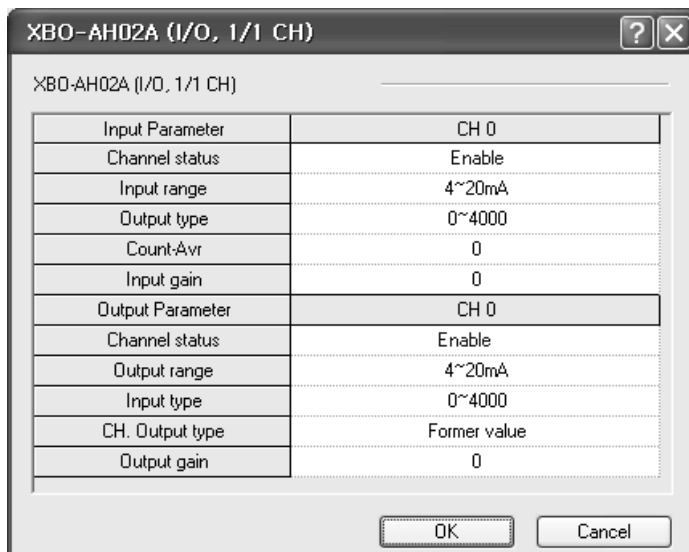
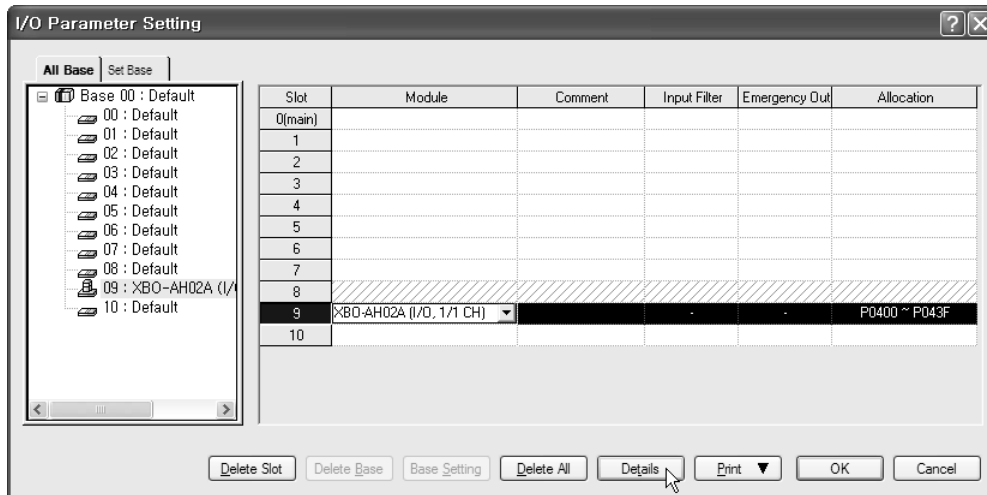

- (a) Input Channel 0 is set to operating channel and input range is set to 4~20mA.
- (b) Output Channel 0 is set to operating channel and output range is set to 4~20mA.

(2) Sample Input Program (XBC Type)

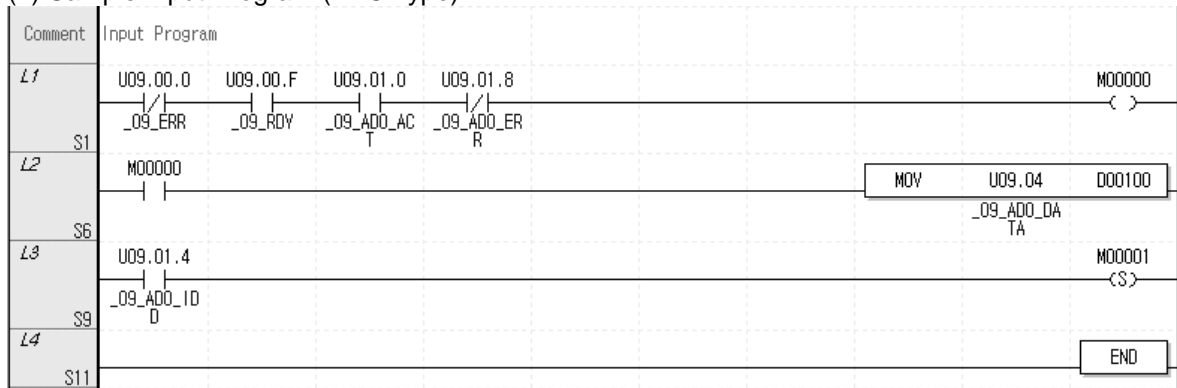

- (a) When the option board is in normal operation, M0000 is turned On.  
 U09.00.0 (Module Error) = Off  
 U09.00.F (Module Ready) = On  
 U09.01.0 (Input Channel 0 in-operation) = On  
 U09.01.8 (Input Channel 0 Error) = Off
- (b) When M0000 is ON, Input Channel 0 Converted Value(U09.04) is moved to D00100.
- (c) If open-wire error occurs in channel 0, U09.01.4 (channel 0 open-wire) is ON, and M0001 bit is set.

(3) Sample Output Program (XBC Type)

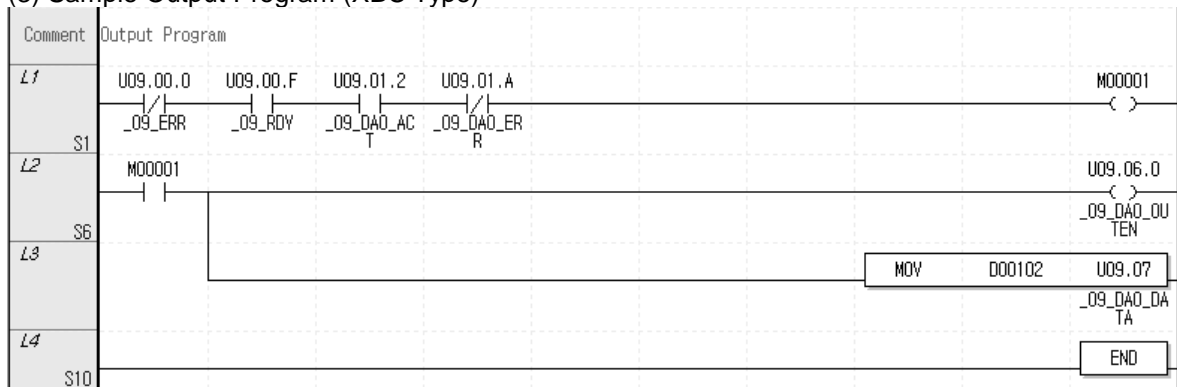

- (a) When the option board is in normal operation, M0000 is turned On.  
 U09.00.0 (Module Error) = Off  
 U09.00.F (Module Ready) = On  
 U09.01.2 (Output Channel 0 in-operation) = On  
 U09.01.A (Output Channel 0 Error) = Off
- (b) When M0000 is ON, it turns on CH0 output state (U09.06.0) and allows output
- (c) When M0000 is ON, D00100 data is moved to output CH0 Output value (U09.07) and outputs.





## 10.13 Troubleshooting

This section describes methods for identifying the troubles which may occur during the operation of analog I/O option board, and their solutions.

### 10.13.1 Troubleshooting

(1) Analog input value is abnormal.

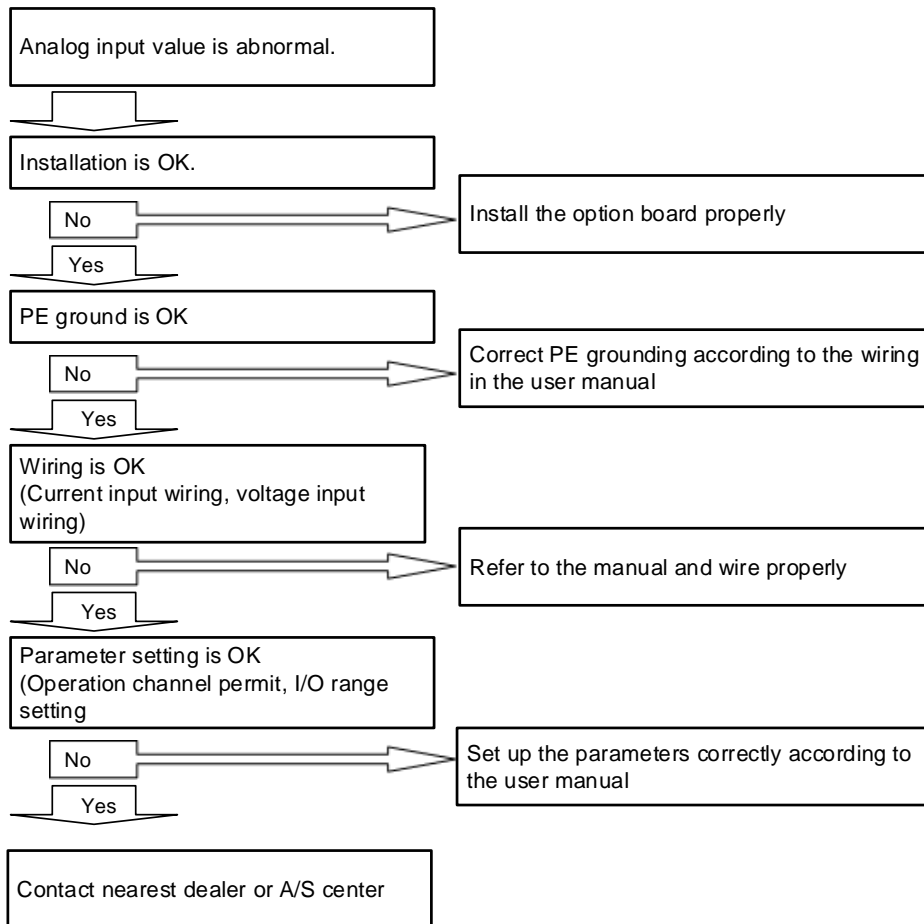

(2) Analog output value is abnormal.

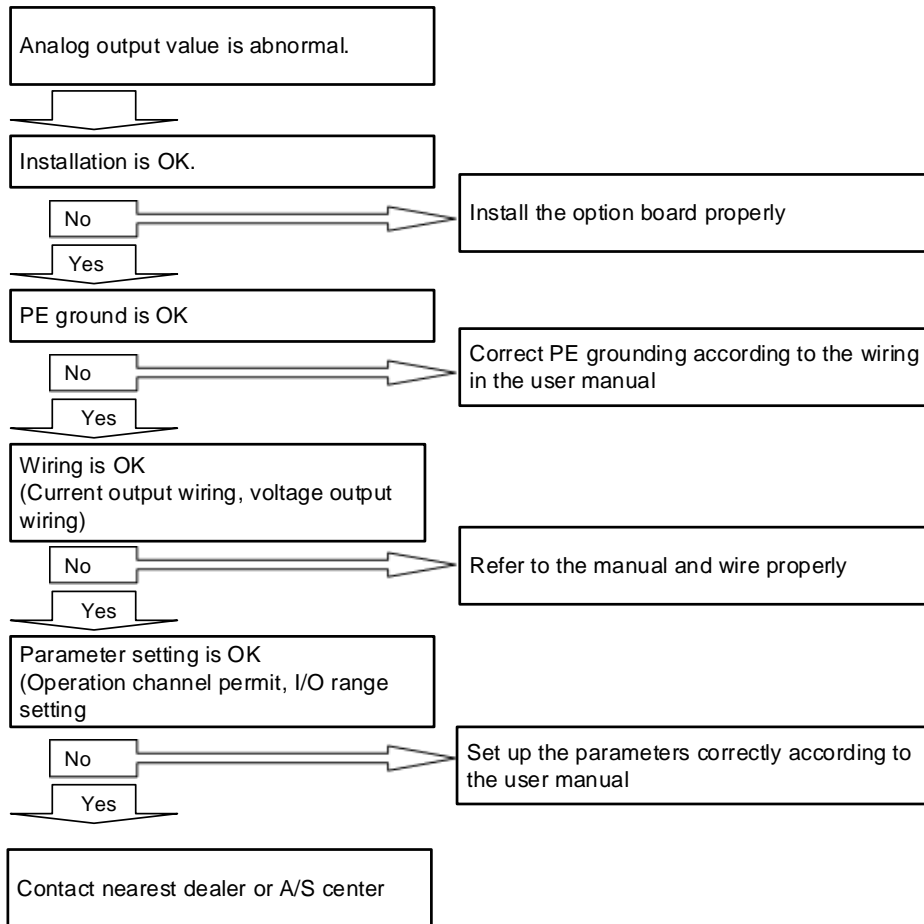

# Chapter 11 RTD Input Option Board

## 11.1 Setting Sequence before Operation

Before using the RTD input option board, follow steps below.

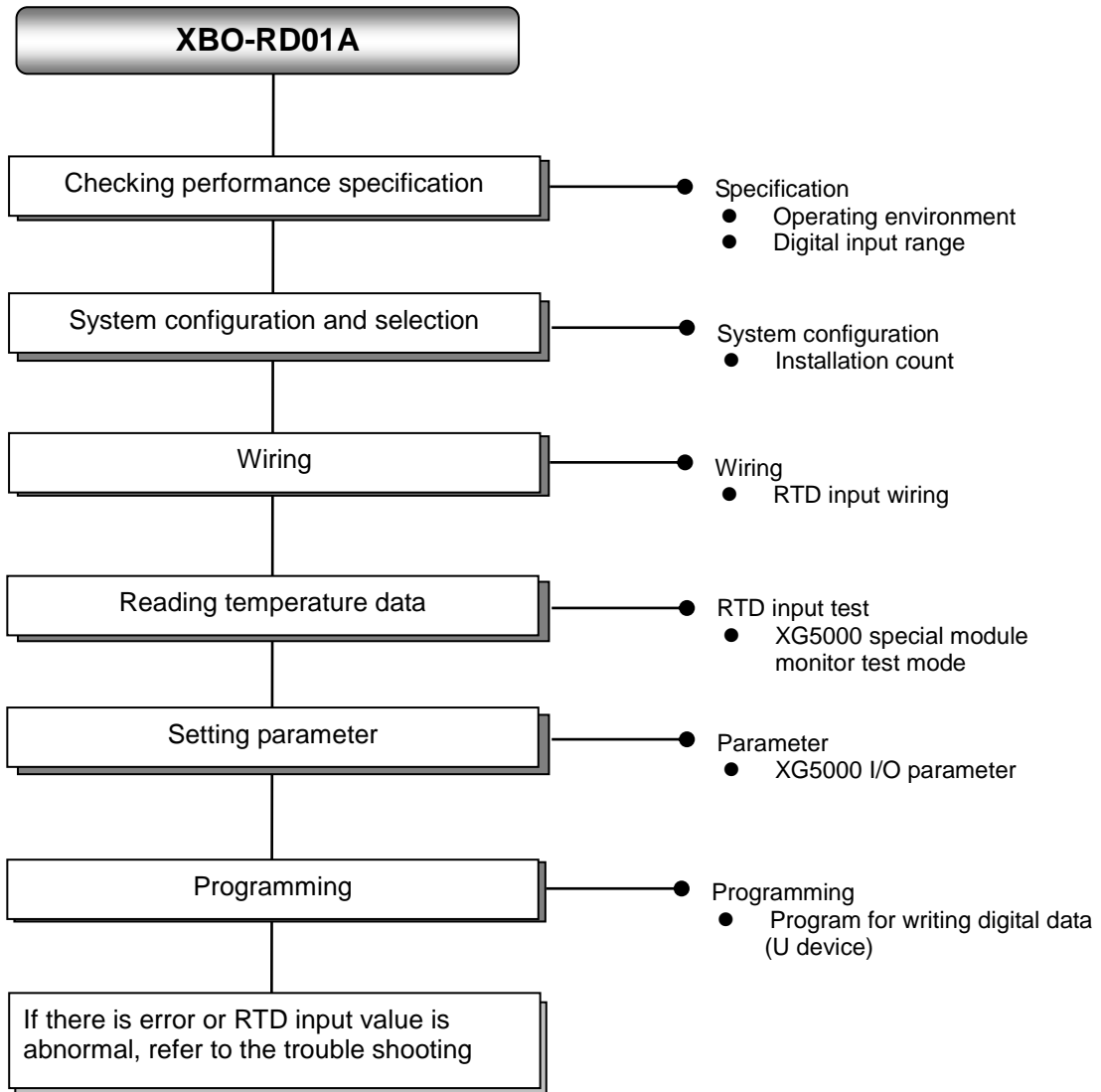

## 11.2 Specification

### 11.2.1 General Specifications

Here describes general specifications of RTD input option board.

No.	Item	Specifications	Related specifications				
1	Ambient temperature	0°C ~ +55°C	-				
2	Storage temperature	-25°C ~ +70°C	-				
3	Ambient humidity	5 ~ 95%RH (Non-condensing)	-				
4	Storage humidity	5 ~ 95%RH (Non-condensing)	-				
5	Vibration resistance	Occasional vibration		-	10 times each directions (X, Y and Z)	IEC61131-2	
		Frequency	Acceleration	Amplitude			How many times
		5 ≤ f < 8.4 Hz	-	3.5 mm			
		8.4 ≤ f ≤ 150 Hz	9.8 m/s <sup>2</sup> (1G)	-			
		For continuous vibration					
		Frequency	Acceleration	Amplitude			
		5 ≤ f < 8.4 Hz	-	1.75 mm			
8.4 ≤ f ≤ 150 Hz	4.9 m/s <sup>2</sup> (0.5G)	-					
6	Shock resistance	<ul style="list-style-type: none"> <li>Peak acceleration: 147 m/s<sup>2</sup>(15G)</li> <li>Duration: 11ms</li> <li>Half-sine, 3 times each direction per each axis</li> </ul>	IEC61131-2				
7	Noise resistance	Square wave Impulse noise	AC: ± 1,500V DC: ± 900V	LS ELETRIC standard			
		Electrostatic discharge	Voltage : 4kV (contact discharging)	IEC 61131-2, IEC 61000-4-2			
		Radiated electromagnetic field noise	80 ~ 1,000 MHz, 10V/m	IEC 61131-2, IEC 61000-4-3			
		Fast transient /bust noise	Segment	Power supply module	Digital/analog input/output communication interface	IEC 61131-2, IEC 61000-4-4	
Voltage	2kV	1kV					
8	Environment	Free from corrosive gasses and excessive dust	-				
9	Altitude	Up to 2,000 ms	-				
10	Pollution degree	Less than equal to 2	-				
11	Cooling	Air-cooling	-				

11.2.2 Performance specifications

Here describes general specifications of RTD input option board.

		XBO-RD01A
No. of input channels		One channel
Input sensor type	PT100	JIS C1604-1997
	JPT100	JIS C1604-1981 , KS C1603-1991
Temperature input range	PT100	-200.0 ~ 600.0°C (-328.0°F ~ 1112.0°F)
	JPT100	-200.0 ~ 600.0°C (-328.0°F ~ 1112.0°F)
Digital output	PT100	-2000 ~ 6000
	JPT100	-2000 ~ 6000
Accuracy		Within ±1.0%
Conversion speed		25ms/1Ch – note1)
Insulation	Channel to Channel	Non-insulation
	Terminal to PLC Power	Insulation (Photo-Coupler)
Terminal block		5-point terminal block
I/O points occupied		Fixed type: 64 points
Wiring method		3-wire type
Function	Averaging	Count averaging function
	Alarm	Disconnection detection
Current consumption	Inner DC5V	30mA
Weight		20g

Note1) Conversion speed can be delayed because of scan delay per channel by XGB main unit

- In order to use analog input option board, the following version is needed.

Main unit	Version information
XBC E type	V1.1 or above
XBC S type	V1.1 or above
XBC SU type	V1.0 or above
XEC E type	V1.0 or above
XEC SU type	V1.0 or above
XG5000	V.3.61 or above

## 11.3 Part Names and Functions

Here describes part names and functions.

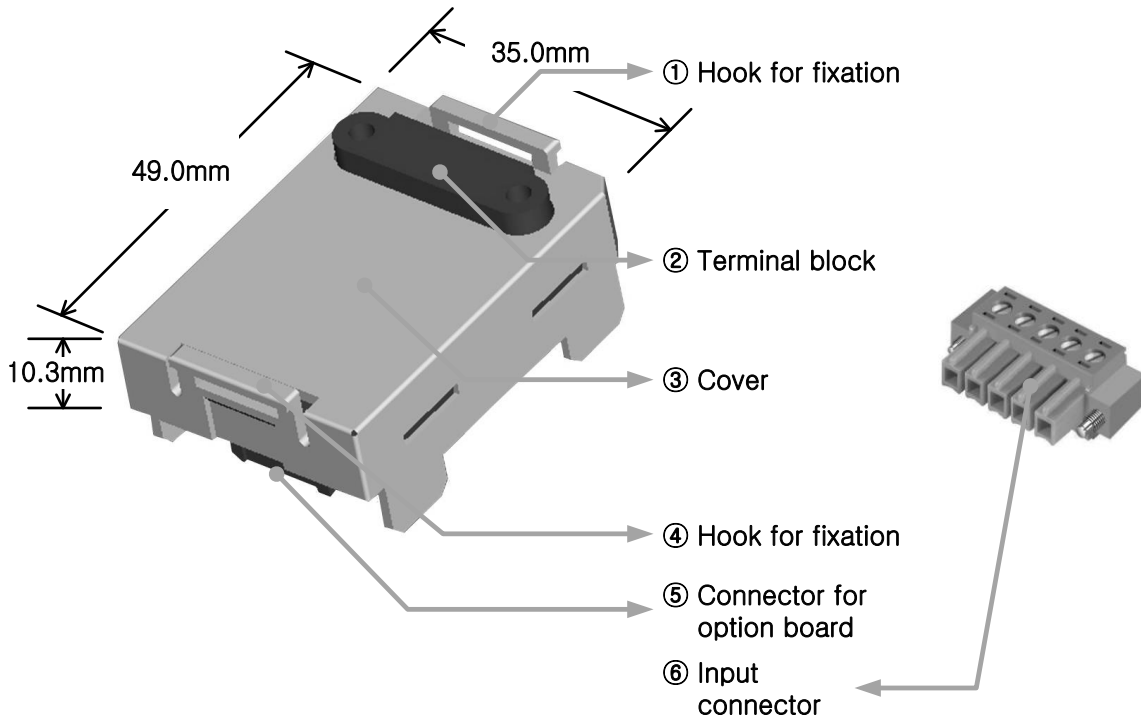

No.	Name	Description
①	Hook for fixation	▶ Hook for fixing the option board to main unit
②	Terminal block	▶ Wiring terminal block to connect with external device (RTD input)
③	Cover	▶ Option board cover
④	Hook for fixation	▶ Hook for fixing the option board to main unit
⑤	Connector for option board	▶ Connection connector for connecting the option board to the main unit
⑥	Input connector	▶ Wiring connector for connecting with the external device

## 11.4 Temperature Conversion Characteristic

Since RTD sensor has non-linear characteristic, RTD input module executes linearization per each section.

The graph below is an example to describe the linearization process and is different with graph about actual sensor temperature input.

(1) PT100: JIS1604-1997

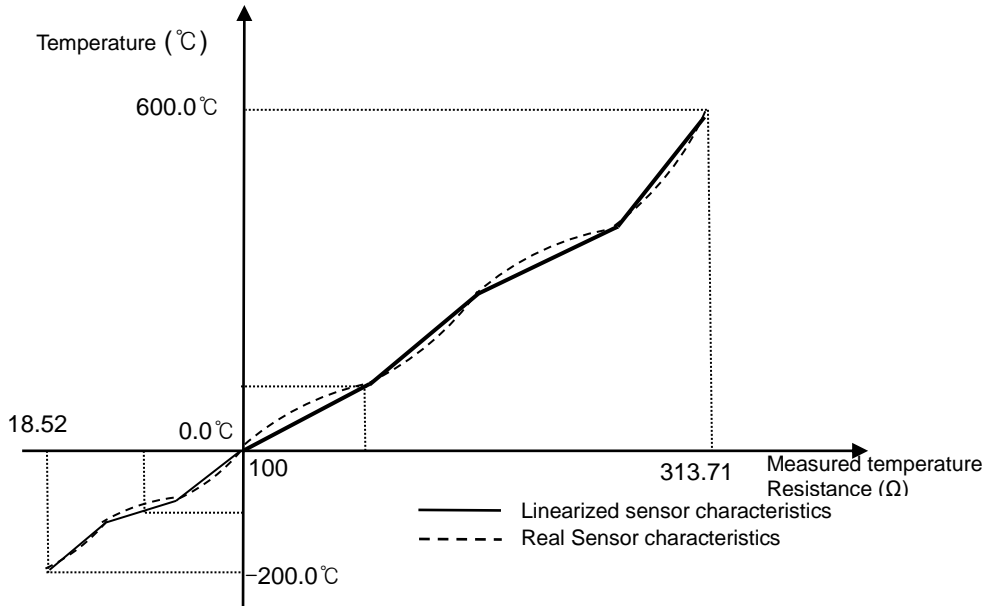

(2) JPT100: JIS C1604-1981, KS C1603-1991

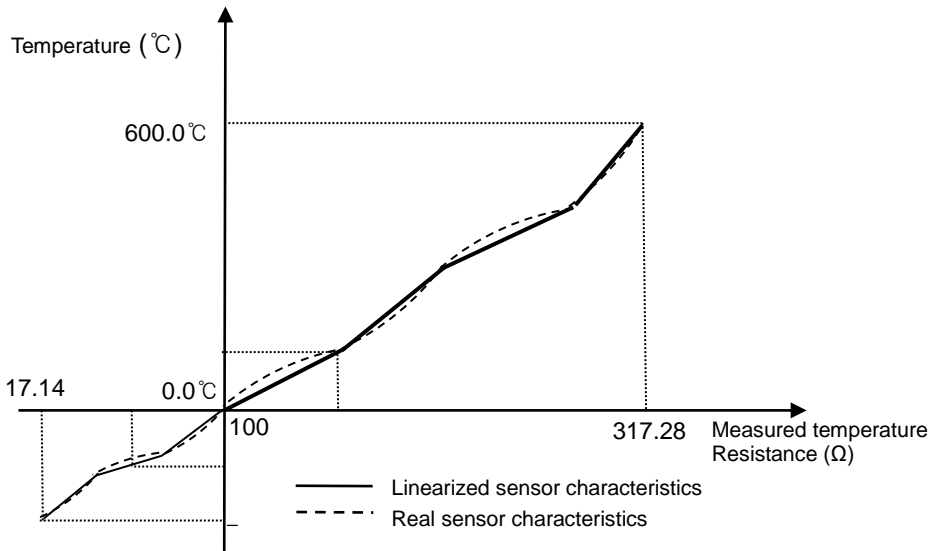

### Remark

Non-linear characteristics: The resistance-temperature characteristics for RTD sensor are presented with table (JIS C1604-1997). This characteristics table displays resistance value of the sensor to temperature, namely, the change of the resistance value per increment of 1°C. When the temperature is changed by 1°C, the change of resistance is not in constant width but in different width per section, which is called the non-linear characteristics.

## 11.5 Conversion Speed

The conversion speed of RTD input option board is less than 25ms + 3 x scan time.  
The conversion speed includes the time to convert input temperature (resistance value) to digital value and to save the converted digital data into the internal memory.

∴ Processing time = less than 25ms + 3 x scan time

## 11.6 Accuracy

The accuracy of RTD module is described below.

- When the ambient temperature is 0 to 55°C: within ±1.0% of available input range

Example) PT100 is used and the ambient temperature is normal.

To measure 100°C, the conversion data output range:

$$100^{\circ}\text{C} - [ \{ 600 - (-200) \} \times 1.0 \% ] \sim 100^{\circ}\text{C} + [ \{ 600 - (-200) \} \times 1.0 \% ]$$

Namely, 92.0 ~ 108.0 [°C]

## 11.7 Temperature Display

(1) The input temperature is converted to digital value down to the one decimal place.

Ex.) If the detected temperature is 123.4°C, its converted value to be saved to the internal memory will be 1234.

(2) Temperature can be converted to Celsius or Fahrenheit scale temperature value as desired.

Ex) If Pt100 sensor is used, the temperature of 100.0°C can be converted to 2120 when Fahrenheit scale is used.

- Conversion °C to °F,  $F = \frac{9}{5}C + 32$

- Conversion °F to °C,  $C = \frac{5}{9}(F - 32)$

(3) temperature input ranges of sensor are as follows;

- PT100 : -200.0 ~ 600.0°C (-328.0°F~1112.0°F)
- JPT100 : -200.0 ~ 600.0°C (-328.0°F~1112.0°F)



## 11.8 Disconnection Detection Function

- (1) As a module used to measure the temperature with the RTD temperature sensor directly connected, it detects and displays disconnection of the sensor connected. If any disconnection occurs in the sensor used and extended lead wire, it will turn on the disconnection diction bit
- (2) The figure below shows the temperature sensor's appearance of the 3-wired RTD.  
(The appearance depends on sensor type)

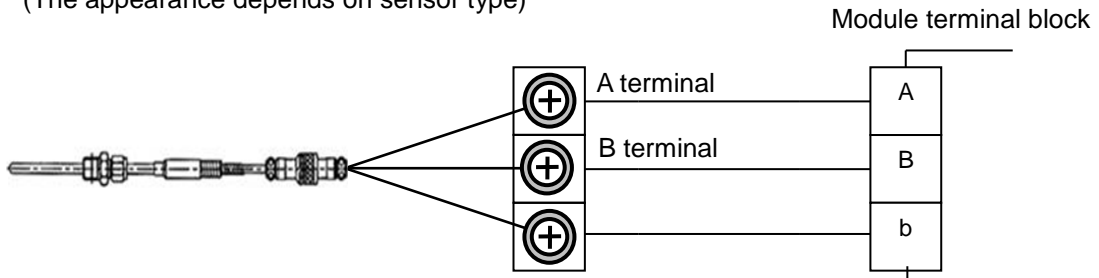

- \* A disconnection: if disconnected between terminal A and module terminal block in the sensor figure.
  - \* B disconnection: if disconnected between terminal B (two for 3-wired sensor) and module terminal block in the sensor figure, or if A and B lines are all disconnected.
- (3) The basic connection between RTD module and RTD Sensor is based on 3-wired RTD sensor. If 2-wired or 4-wired sensor is used, the connection between the sensor and the module shall be kept as 3-wired. Disconnection will be detected on the basis of 3-wired wiring.
  - (4) In case of disconnection, operation of disconnection flag is as follows.

Connection status	Channel status	Disconnection flag
Normal	Run	Off
	Stop	Off
Disconnection	Run	On
	Stop	Off
Any sensor is not connected	Run	On
	Stop	Off

## 11.9 Wiring

- 3 types of sensor-connecting methods are available (2, 3 and 4-wired).
- The standard wiring method for XBO-RD1A module is 3-wired wiring.
- Use an identical type of wire (thickness, length, etc.) for each 3 wire when extended lead wire is used.
- The resistance of each conductor is to be less than 10Ω. (If larger than this, it will cause an error.)
- Resistance difference of each conductor is to be less than 1Ω. (If larger than this, it will cause an error.)
- Length of wire is to be as short as possible and it is recommended to connect the wire directly to the terminal block of module without connection terminal unit. If a connection terminal is to be used, compensating wire shall be connected as shown below.

### 11.9.1 If 2-wired sensor is used (connection terminal unit is used)

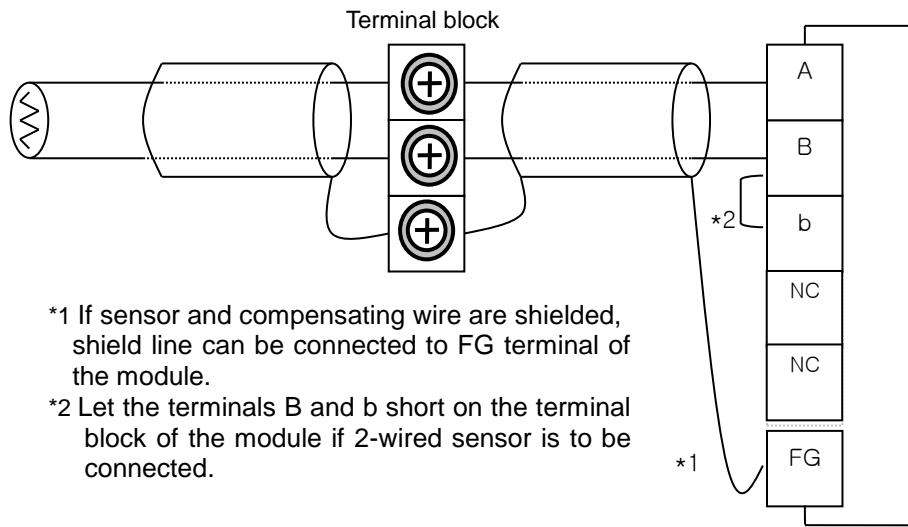

### 11.9.2 If 3-wired sensor is used (connection terminal unit is used)

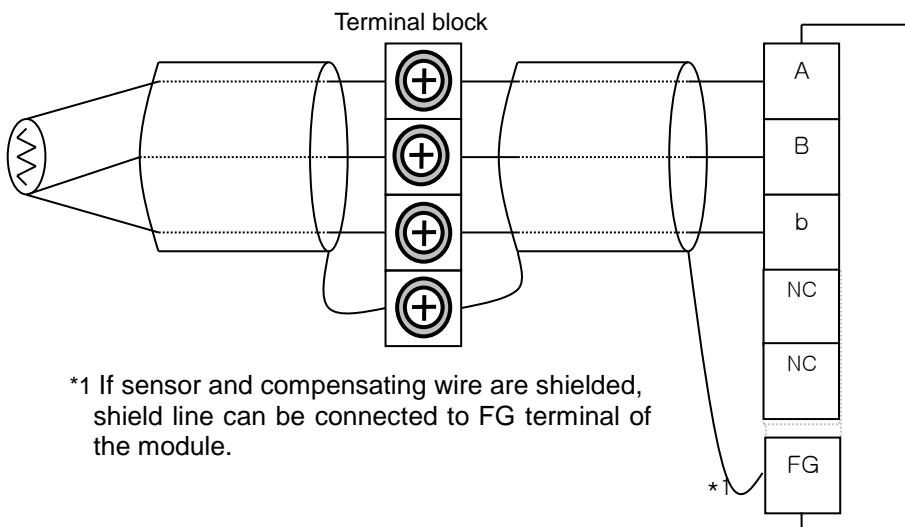

11.9.3 If 4-wired sensor is used (connection terminal unit is used)

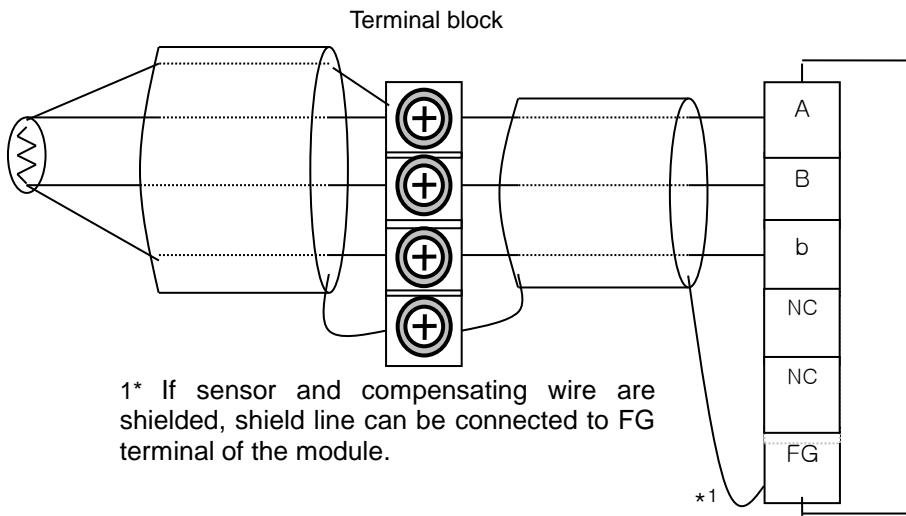

## 11.10 Average Function

It accumulates temperature conversion values of a selected channel as many as average value and displays the average of the total sum in digital data

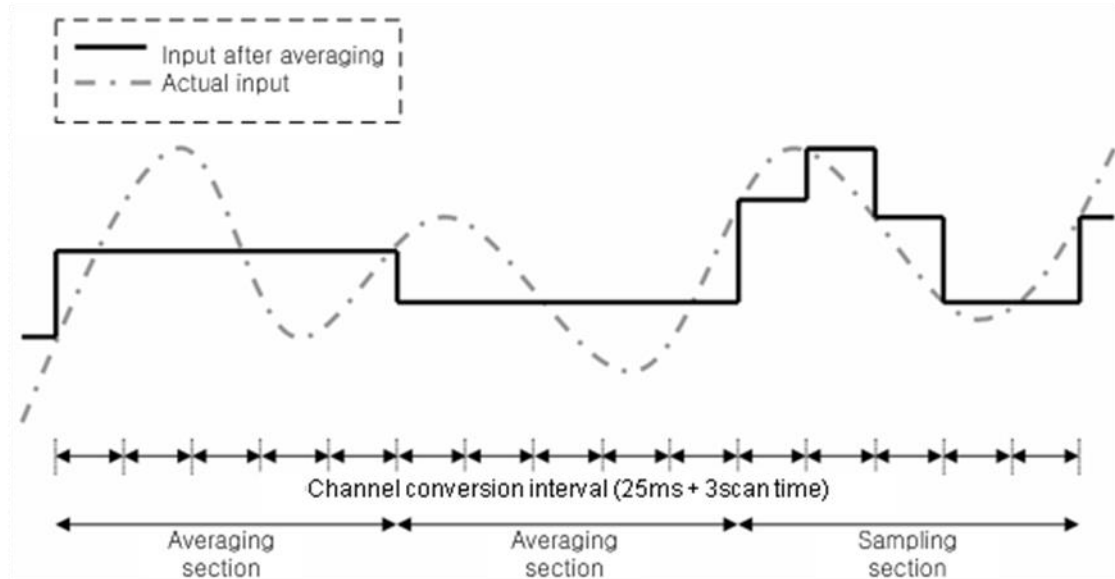

- Setting range = 2 ~ 64000 [times]
- Averaging interval is calculated according to the number of channel used
- Averaging interval[ms] = Averaging count x (25ms + 3\*scan time)

### Remark

(1) Averaging interval varies according to change of scan time.

## 11.11 Operation Parameter Setting

Operation parameters of RTD input option board can be specified through [I/O parameters] of XG5000.

### 11.11.1 Setting items

For the user's convenience, XG5000 provides GUI (Graphical User Interface) for parameters setting of RTD module. Setting items available through [I/O parameters] of the XG5000 project window are described below.

Item	Details
[I/O Parameter]	(1) Specify the following setting items necessary for the module operation. <ul style="list-style-type: none"> <li>- Channel Run/Stop</li> <li>- Sensor type</li> <li>- Temp. unit</li> <li>- Count average</li> </ul> (2) The data specified by user through S/W package will be saved on the flash memory of basic unit when [I/O Parameters] are downloaded.

### 11.11.2 How to use [I/O Parameter]

- (1) Run XG5000 to create a project. (Refer to XG5000 programming manual for details on how to create the project)
- (2) Double-click [I/O Parameter] on the project window.

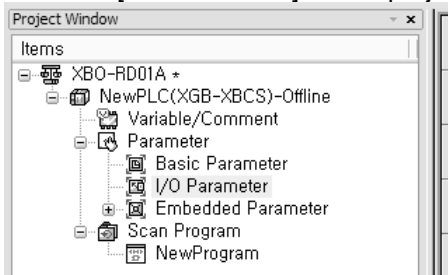

- (3) On the 'I/O parameters setting' screen, find and click the slot of the base where RTD option board is installed on.

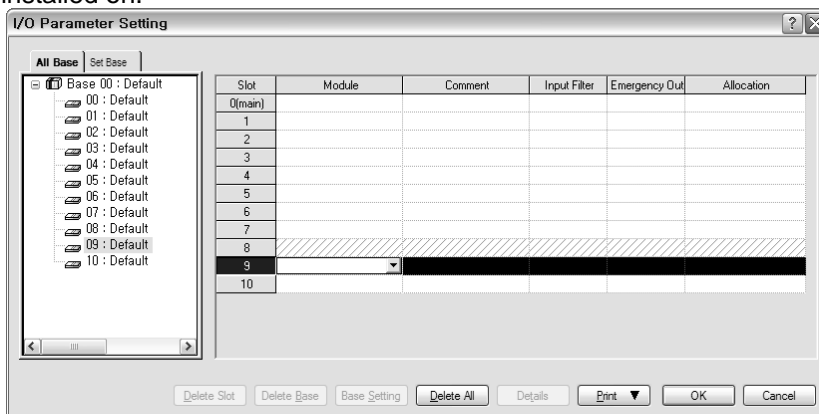

(4) Click the arrow button on the screen to display the screen where an applicable option board can be selected. Search for the applicable option board to select.

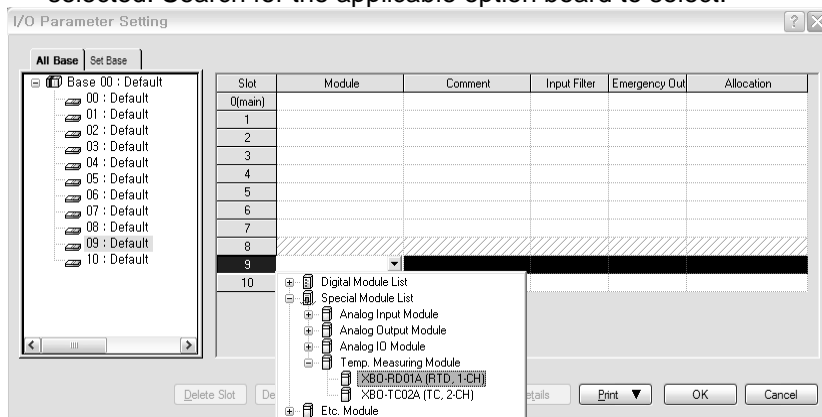

(5) After the option board selected, click [Details] or double-click relevant slot.

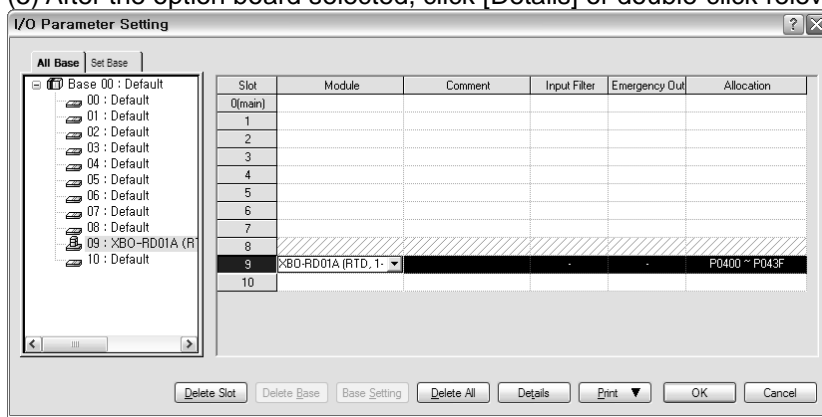

(6) A screen will be displayed to specify parameters for respective channels as shown below. Click a desired item to display parameters to set for respective items.

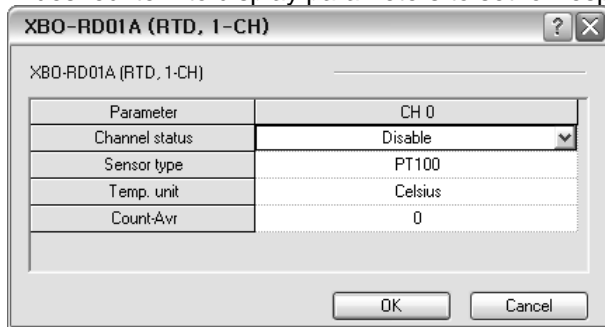

(7) The initial values of respective items are as follows.

(a) Channel status setting screen

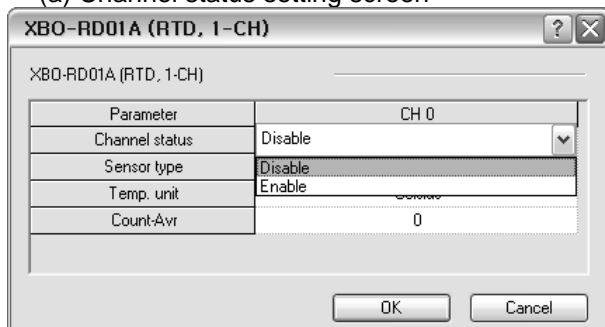

(b) Input sensor type setting screen

Parameter	CH 0
Channel status	Enable
Sensor type	PT100
Temp. unit	PT100
Count-Avr	PT100

Buttons: OK, Cancel

(c) Temp. unit setting screen

Parameter	CH 0
Channel status	Enable
Sensor type	PT100
Temp. unit	Celsius
Count-Avr	Celsius Fahrenheit

Buttons: OK, Cancel

(d) Count average setting screen

Parameter	CH 0
Channel status	Enable
Sensor type	PT100
Temp. unit	Celsius
Count-Avr	0

0, 2~64000

Buttons: OK, Cancel

(8) If necessary setting is complete, press OK.

## 11.12 Special Module Monitoring

Run Special Module Monitoring by selecting [Online] -> [Connect] and [Monitor] -> [Special Module Monitoring]. If the status is not [On-Line], [Special Module Monitoring] menu will not be activated.

### Remark

- 1) If the program is not displayed normally because of insufficient system resource, you may start XG5000 again after close the program and other applications.
- 2) I/O parameters those are specified in the state of [Special Module Monitoring] menu are temporarily set up for the test. They will be disappeared when the [Special Module Monitoring] is finished.
- 3) Testing of [Special Module Monitoring] is the way to test the analog output module. It can test the module without a sequence program.

### 11.12.1 How to use special module monitoring

- (1) Start of [Special Module Monitoring]

Go through [Online] → [Connect] and [Monitor] → [Special module Monitoring] to start. If the status is not online, [Special Module Monitoring] menu will not be activated.

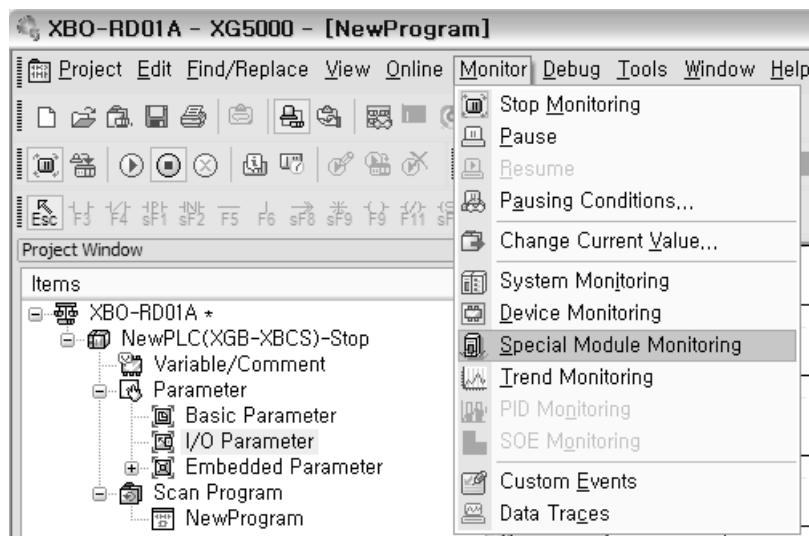



- (2) How to use [Special Module Monitoring]  
 (a) [Special Module List] window will show base/slot information and types of special module by click [Monitor] → [Special Module Monitoring]. In this list box, the modules that are now installed in PLC system will be displayed.

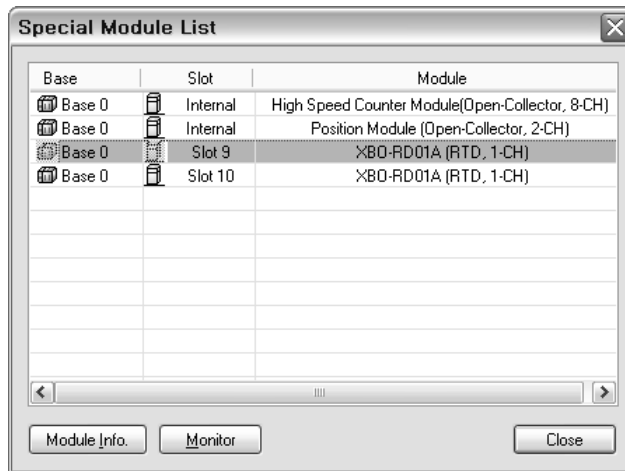

- (b) Select a special module then click [Module Info.] button to display the information as described below.

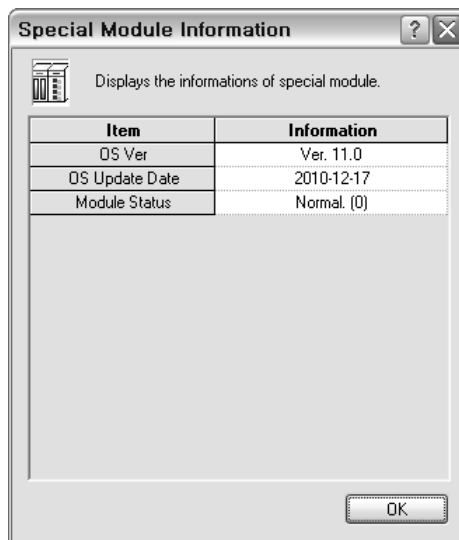

- (c) Select a special module then click [Start Monitoring] button to display the information as described below.

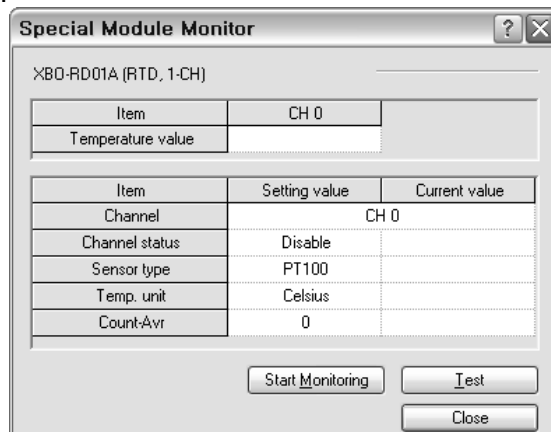

- (d) [Start Monitoring]: [Start Monitoring] button will show you digital input data of the operating channel. The figure below is monitoring screen when all channels are Run status.

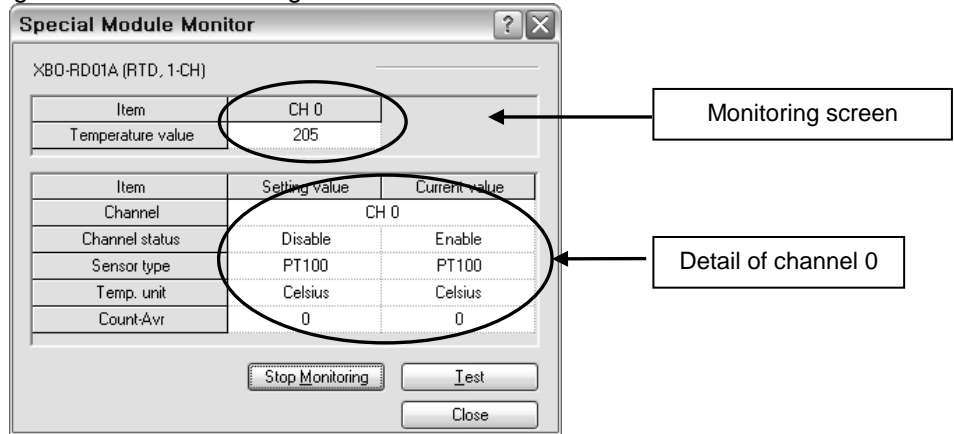

[Start Monitoring] execution screen

- (e) [Test]: [Test] is used to change the parameters of the RTD input module. You can change the parameters when you click the values at the bottom of the screen. It is only available when XGB CPU unit's status is in [Stop].

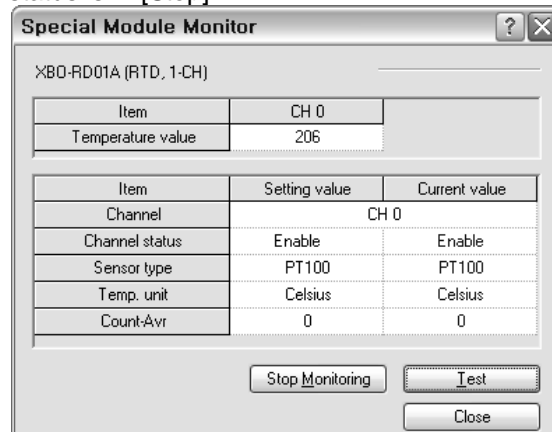

[Test] execution screen

- (g) [Close]: [Close] is used to escape from the monitoring/test screen. When the monitoring/test screen is closed, the max. value, the min. value and the present value will not be saved any more.

**Remark**

[Test] function is only available when XGB CPU unit's status is in [Stop].

## 11.13 Register U devices (Special module variable)

Register the variables for each module referring to the special module information that is set in the I/O parameter. The user can modify the variables and comments.

(1) Procedure

- (a) Select the special module in the [I/O Parameter Setting] window.

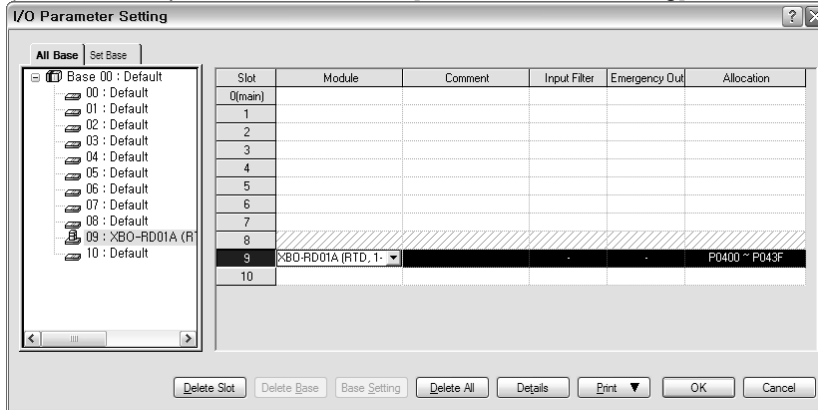

- (b) Double click 'Variable/Comment' from the project window. .

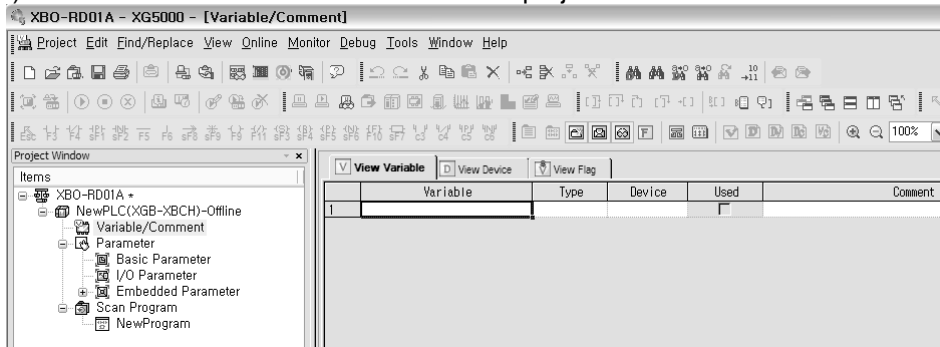

- (c) Select [Edit] – [Register U Device].

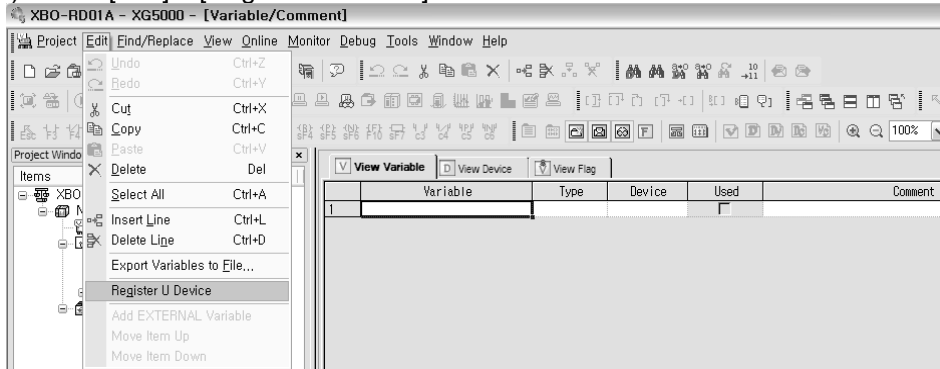

(d) Click 'Yes'.

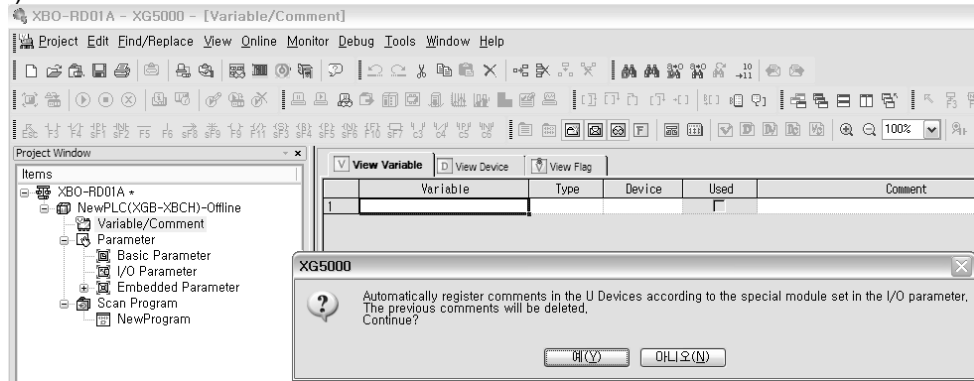

(e) As shown below, the variables are registered.

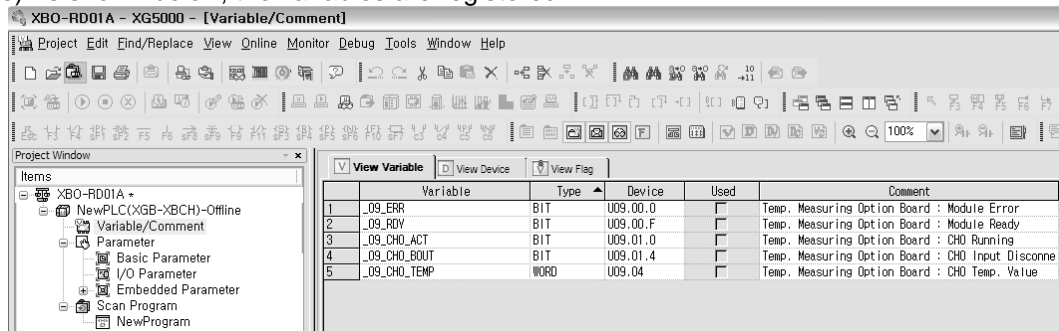

(2) Save variables

- (a) The contents of 'View Variable' can be saved as a text file.
- (b) Select [Edit] -> [Export to File].
- (c) The contents of 'View variable' are saved as a text file.

(3) View variables

Example in the XGB compact "E" type and "S" type are as follows.

(a) The example program of XG5000 is as shown below.

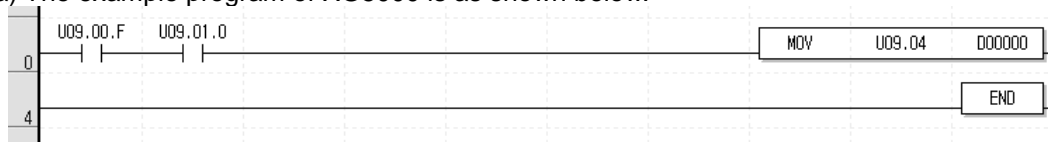

(b) Select [View] -> [Variables]. The devices are changed into variables.

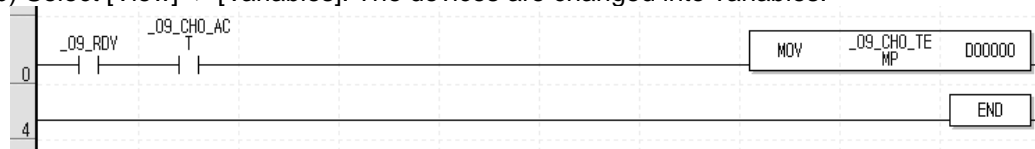

(c) Select [View] -> [Devices/Variables]. Devices and variables are both displayed.

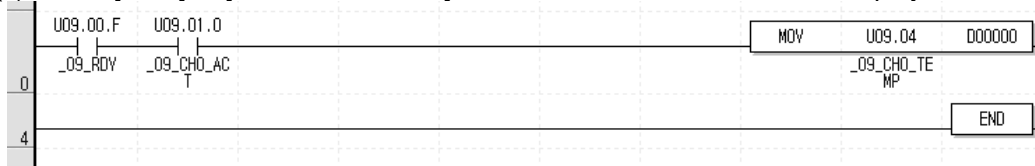

(d) Select [View] -> [Device/Comments]. Devices and comments are both displayed.

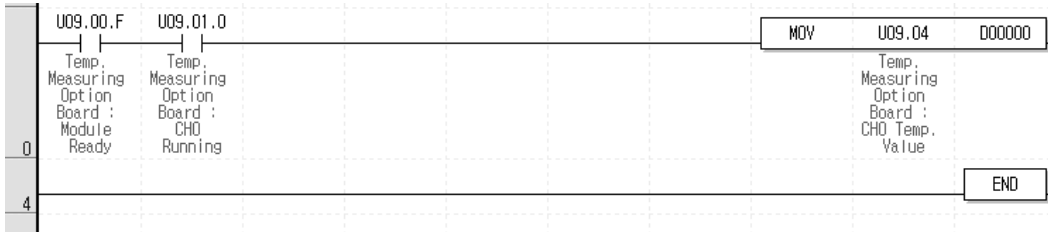

(e) For IEC type also, as shown in Fig. (a) ~ (d), you can look up variables with diversified options in the 'View' menu. The figure below is the case of an IEC type with which the 'View Device/Variables' option.

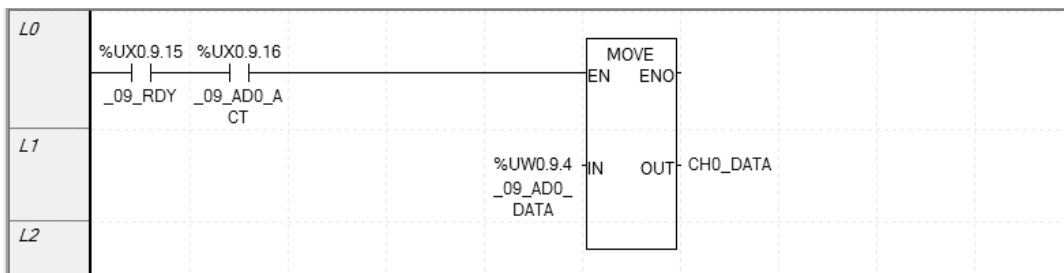

## 11.14 Configuration and Function of Internal Memory

Here describes configuration and function of internal memory.

### 11.14.1 Data I/O area

Data I/O area of RTD input option board is as shown below.

Variable	Type	Device		Description	R/W	Signal direction
		XBC	IEC			
_0y_ERR	Bit	U0y.00.0	%UX0.y.0	Module error	R	Option → CPU
_0y_RDY	Bit	U0y.00.F	%UX0.y.15	Module Ready	R	
_0y_CH0_ACT	Bit	U0y.01.0	%UX0.y.16	CH0 running	R	Option → CPU
_0y_CH0_BOUT	Bit	U0y.01.4	%UX0.y.20	CH0 disconnection	R	Option → CPU
_0y_CH0_TEMP	Word	U0y.04	%UW0.y.4	CH0 temp. value	R	Option → CPU

- In the device allocation, the small letter 'y' is the No. of the slot where the module is installed.
- For example, to read the 'CH0 Temperature Value' of the RTD module installed in the slot 9, write in U09.05. (%UW0.9.4 for IEC types)

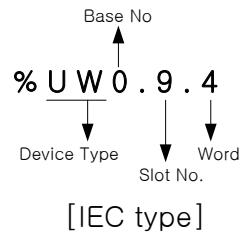
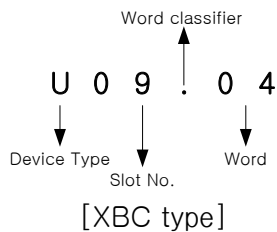

- (1) Module ready/error flag ( ) is for IEC types, y: slot No.)
  - (a) U0x.00.F: It will be ON when PLC CPU is powered or reset with A/D conversion ready to process A/D conversion.
  - (b) U0x.00.0: It is a flag to display the error status of A/D conversion option board.

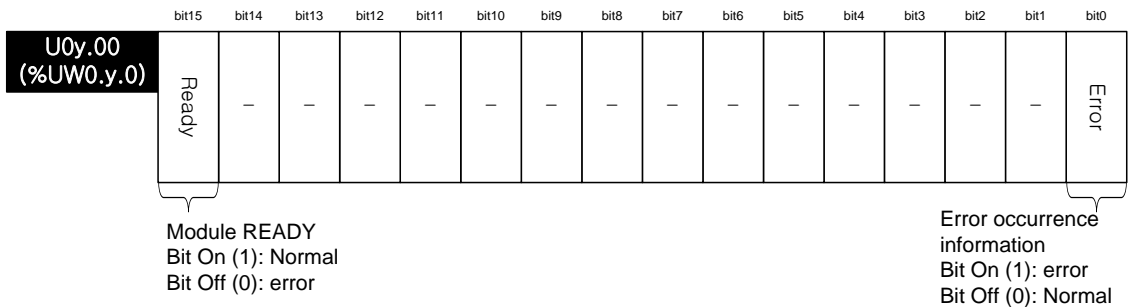

- (2) Channel run, stop information / channel disconnection information flag  
It displays which channel is being used. ( ) is for IEC types, y: slot No.)

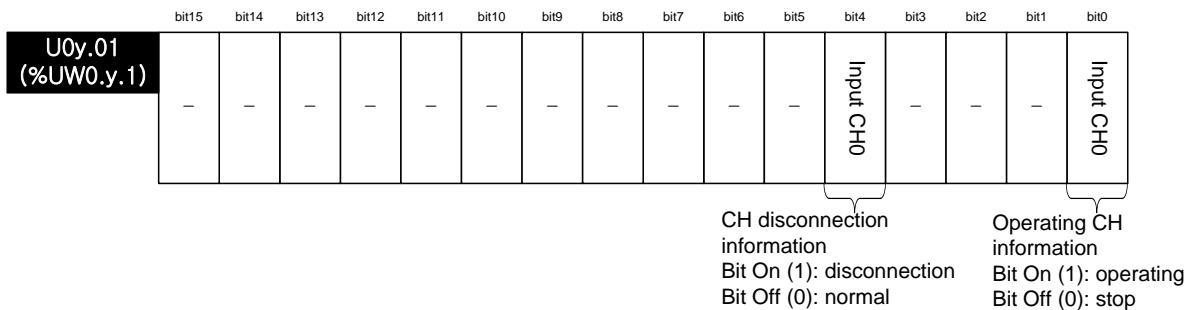

- (3) Temperature value ( ) is for IEC types, y: slot No.)  
It displays current temperature value. Its form is temperature value ×10.



### 11.14.2 Operation parameter setting area

Operation parameter setting areas of RTD input option board are as follows.

Memory address	Contents	Setting value	R/W	Instruction
0	Channel enable/disable setting	CH status setting 0: Stop 1: Run	R/W	PUT/GET
1	sensor type setting	Input range setting 0: PT100 1: JPT100	R/W	
5	Temperature display unit setting	Data type setting 0: Celsius 1: Fahrenheit	R/W	
6	disconnection information	0: Normal 1: Disconnection	R	GET
14	Count average value	0 or 2~64,000	R/W	PUT GET
15	Error information	100: sensor type setting error 300: count average value setting error	R	GET



- (1) Run channel setting (address 0)
  - (a) You can enable/disable the RTD input option board
  - (b) If Run channel is not specified, all channels will be stop status.
  - (c) When using Put instruction, Channel Status address is as follows

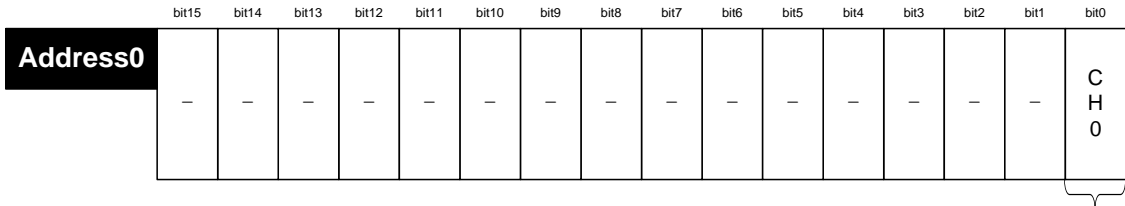

Enable CH  
 Bit On (1): enable  
 Bit Off (0): disable

- (d) Values set in B1 ~ B15 are ignored.
- (e) This area shows the same results with “Channel status” in I/O parameter setting window.

- (2) Sensor type setting (address 1)
  - (a) Sets sensor type with the following code.

Word	Sensor type
0	PT100
1	JPT100

- (b) When input value is larger than 2, 0 (PT100 type) is selected by force.
- (c) In case of using PUT instruction, Sensor Type Setting Area is as follows.

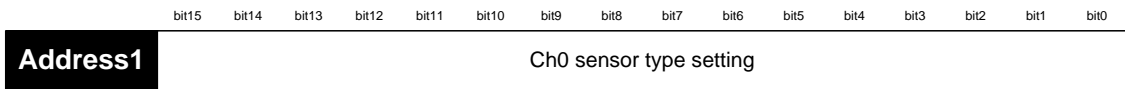

Sensor type setting  
 0: PT100  
 1: JPT 100

- (3) Setting temperature display unit (address 5)
  - (a) Sets temp. display unit with the following code.

Bit	Temp. display unit
0	Celsius
1	Fahrenheit

- (b) When input value is larger than 2, 0 (Celsius) is selected by force.
- (c) In case of using PUT instruction, Output Data Type Area is as follows.



Temp. unit setting  
 Bit Off(0): Celsius  
 Bit On(1): Fahrenheit

- (4) Disconnection information (address 6)
  - (a) Displays disconnection information of channel.
  - (b) In case of using GET instruction, Disconnection Information address is as follows.

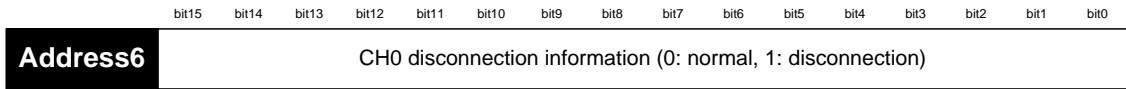

- (5) Count average value setting (address 14)
  - (a) Count average value should be 0 or 2~64000.
  - (b) If count average value is set as 0, averaging process is not applied and sampling-processed temperature value is outputted.
  - (c) When count average value is larger than 64001, 0 (Averaging disabled) is selected by force
  - (d) In case of using PUT instruction, Count Average Value Setting address is as follows.

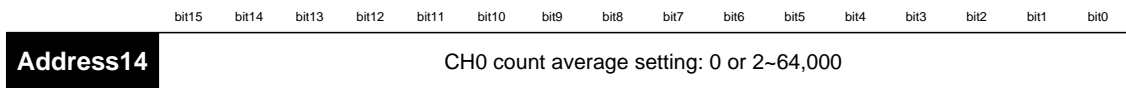

- (6) Error information (address 15)
  - (a) Saves error code detected at setup (in case of setup by the program)
  - (b) Setting error is canceled when invalid setting is corrected by resetting
  - (c) In case of GET instruction, setting error information address is as follows.

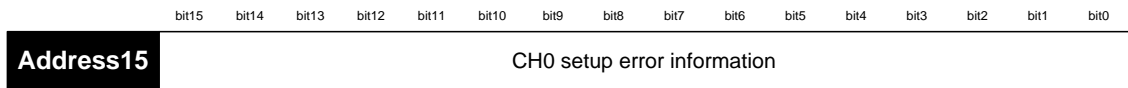

Type	Error code	Description	Priority	Remark
Setup error	100	Input sensor type setting error	1	-
	300	Input count average value rage setting error	2	

11.15 Example Program

- Here describes how to specify the operation condition of RTD input option board.
- RTD input option board is installed on slot 9.
- Initial setting value is saved in internal memory of module with one input.
- The following program is an example to read temperature value and disconnection information.

(1) Program example using [I/O Parameter Setting]

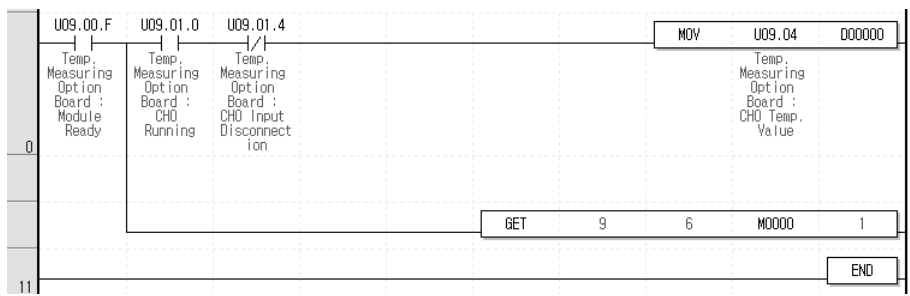
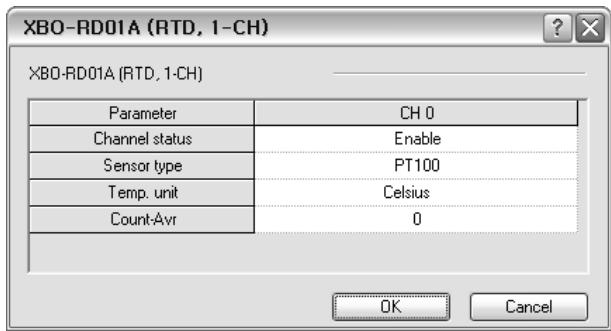
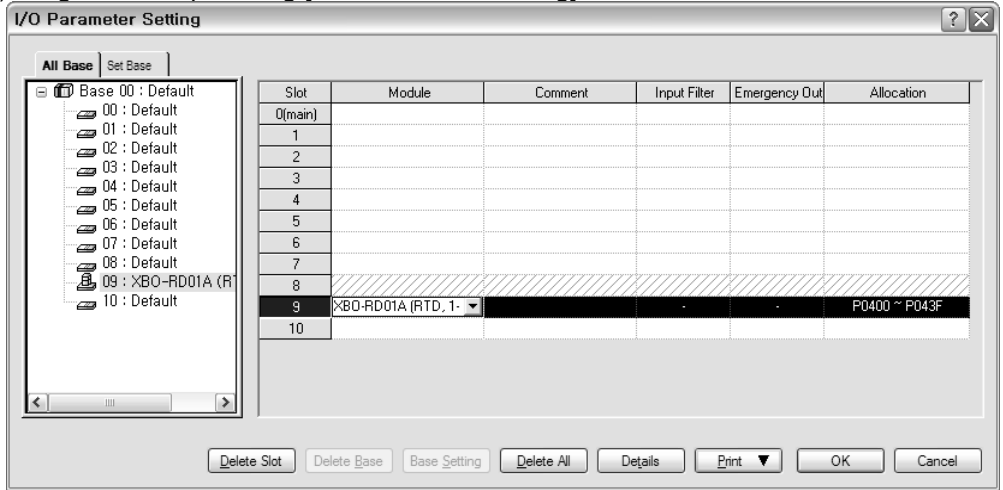

Moving channel 0 temp. value to D0 area

Moving channel 0 disconnection information to M0

(2) Program example using PUT/GET command

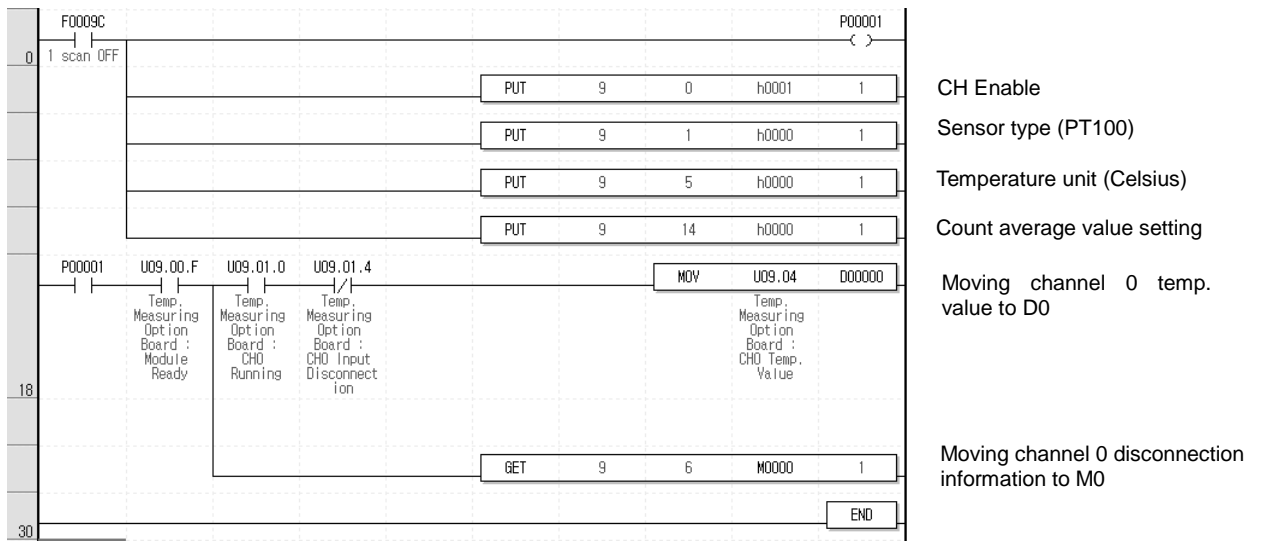

## 11.16 Troubleshooting

Describes troubleshooting about the problem that occurs during using RTD input option board

### 11.16.1 Troubleshooting

(1) Temperature conversion value is not normal.

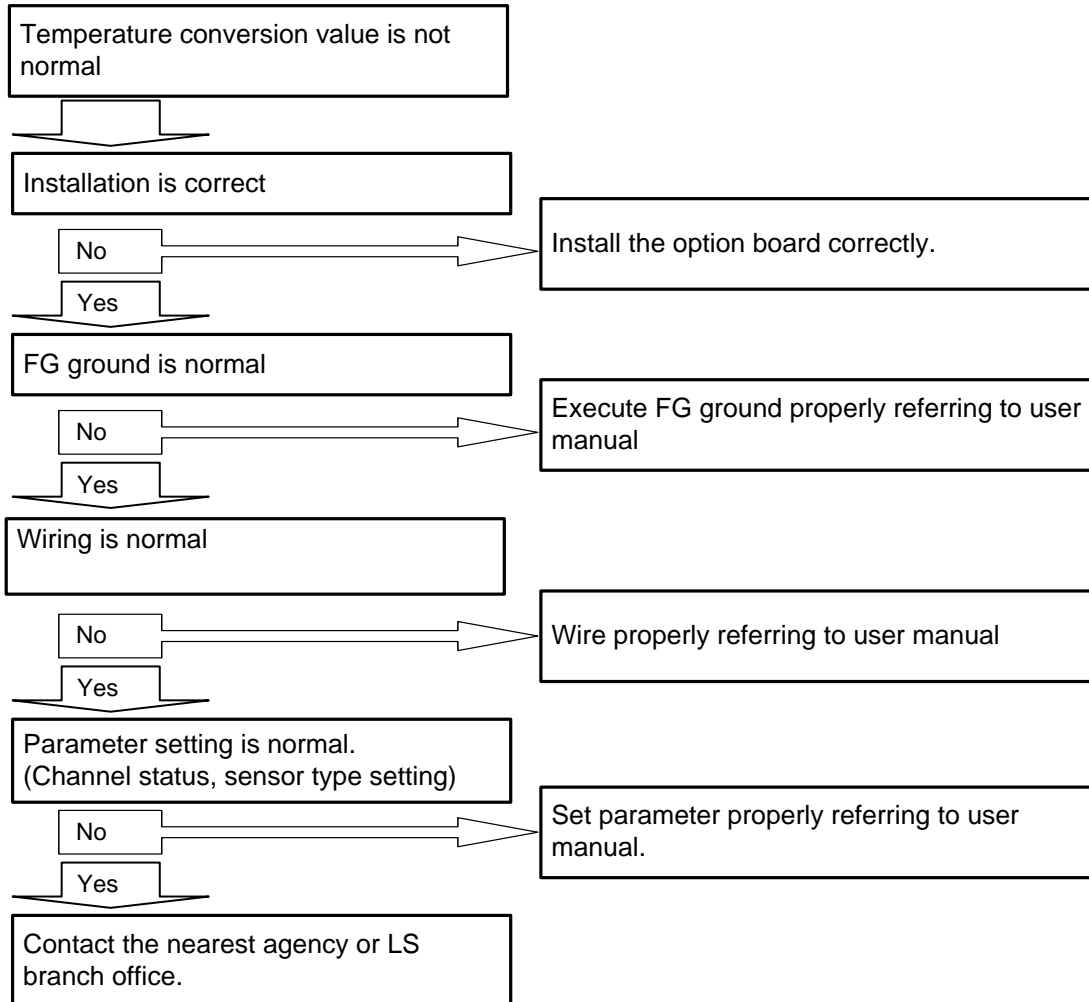

### 11.16.2 Stats check of RTD input option board through XG5000 system monitor

Module type, module information, O/S version and module status of RTD input module can be checked through XG5000 system monitoring function.

(1) Execution sequence

Two routes are available for the execution.

- (a) [Monitor] -> [System Monitoring] -> And on the module screen, click the right mouse button to display [Module Information].
- (b) [Monitor] -> [System Monitoring] -> And Double-click the module screen.

(2) Module information

- (a) Module type: shows the information of the module presently installed.
- (b) Module information: shows the O/S version information of module.
- (c) O/S version: shows the O/S prepared date of module.
- (d) Module status: shows the present error code.



# Chapter 12 Thermocouple Input Option Module

## 12.1 Setting sequence before operation

### Setting sequence before operation

Before using the thermocouple input module, follow steps below.

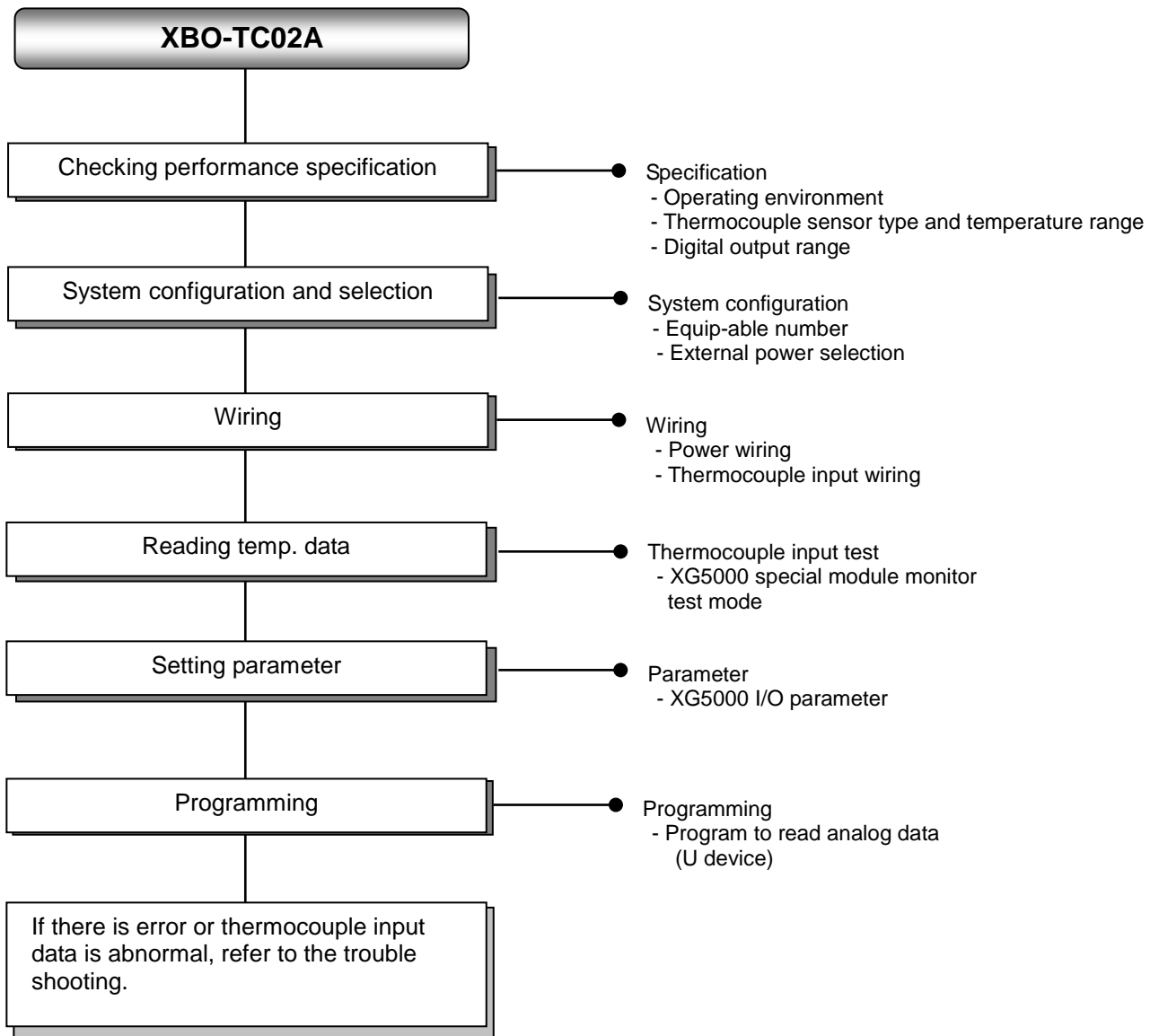

## 12.2 Specification

### 12.2.1 General specification

General specifications of thermocouple input option module are as follows.

No.	Item	Specifications	Related specifications				
1	Ambient temperature	0°C ~ +55°C	-				
2	Storage temperature	-25°C ~ +70°C	-				
3	Ambient humidity	5 ~ 95%RH (Non-condensing)	-				
4	Storage humidity	5 ~ 95%RH (Non-condensing)	-				
5	Vibration resistance	Occasional vibration			-	10 times each directions (X, Y and Z)	IEC61131-2
		Frequency	Acceleration	Amplitude	How many times		
		5 ≤ f < 8.4 Hz	-	3.5 mm	10 times each directions (X, Y and Z)		
		8.4 ≤ f ≤ 150 Hz	9.8 m/s <sup>2</sup> (1G)	-			
		For continuous vibration			10 times each directions (X, Y and Z)		
		Frequency	Acceleration	Amplitude			
		5 ≤ f < 8.4 Hz	-	1.75 mm			
		8.4 ≤ f ≤ 150 Hz	4.9 m/s <sup>2</sup> (0.5G)	-			
6	Shock resistance	<ul style="list-style-type: none"> <li>Peak acceleration: 147 m/s<sup>2</sup>(15G)</li> <li>Duration: 11ms</li> <li>Half-sine, 3 times each direction per each axis</li> </ul>	IEC61131-2				
7	Noise resistance	Square wave Impulse noise	AC: ± 1,500V DC: ± 900V	LSIS standard			
		Electrostatic discharge	Voltage : 4kV (contact discharging)	IEC 61131-2, IEC 61000-4-2			
		Radiated electromagnetic field noise	80 ~ 1,000 MHz, 10V/m	IEC 61131-2, IEC 61000-4-3			
		Fast transient /bust noise	Segment Voltage	Power supply module 2kV	Digital/analog input/output communication interface 1kV	IEC 61131-2, IEC 61000-4-4	
8	Environment	Free from corrosive gasses and excessive dust	-				
9	Altitude	Up to 2,000 ms	-				
10	Pollution degree	Less than equal to 2	-				
11	Cooling	Air-cooling	-				



### 12.2.2 Performance Specification

Performance specifications are as follows

Items		Specification
Number of input channel		2 channels
Type of input sensor		Thermocouple K / J type (JIS C1602-1995)
Range of input temperature	K type sensor	-200.0°C ~ 1300.0°C (-328.0°F ~ 2372.0°F)
	J type sensor	-200.0°C ~ 1200.0°C (-328.0°F ~ 2192.0°F)
Digital output	Temp. display unit	16 bit binary data Displaying down to one decimal place (K, J, type: 0.1°C)
Accuracy		±1.0% or less
Conversion speed		50ms/2channels –note1)
Reference junction compensation	Auto compensation by RJC sensing (Thermistor)	
	Compensation amount	±1.0°C
Additional function	Average process	Count averaging
	Alarm	Input disconnection detection
Warming-up time		15 min or above – note2)
Insulation method		Non-insulation between input channels Non-insulation between input terminal and PLC main unit
I/O terminal		5-point terminal block
Supply power		Internal 5V
I/O occupied points		Fixed type: 64 points
Consumption current(Internal)		50mA
Weight		20g

Note1) Conversion speed can be delayed because of scan delay per channel by XGB main unit

Note2) Warming-up time: for stability of measured temperature, 15 min is necessary after power is on.

- In order to use analog input option board, the following version is needed.

Main Unit	Version
XBC E type	V1.1 or above
XBC S type	V1.1 or above
XBC SU type	V1.0 or above
XEC E type	V1.0 or above
XEC SU type	V1.0 or above
XG5000	V.3.61 or above

### 12.3 Name and Function of Each Part

Describes name and function of each part

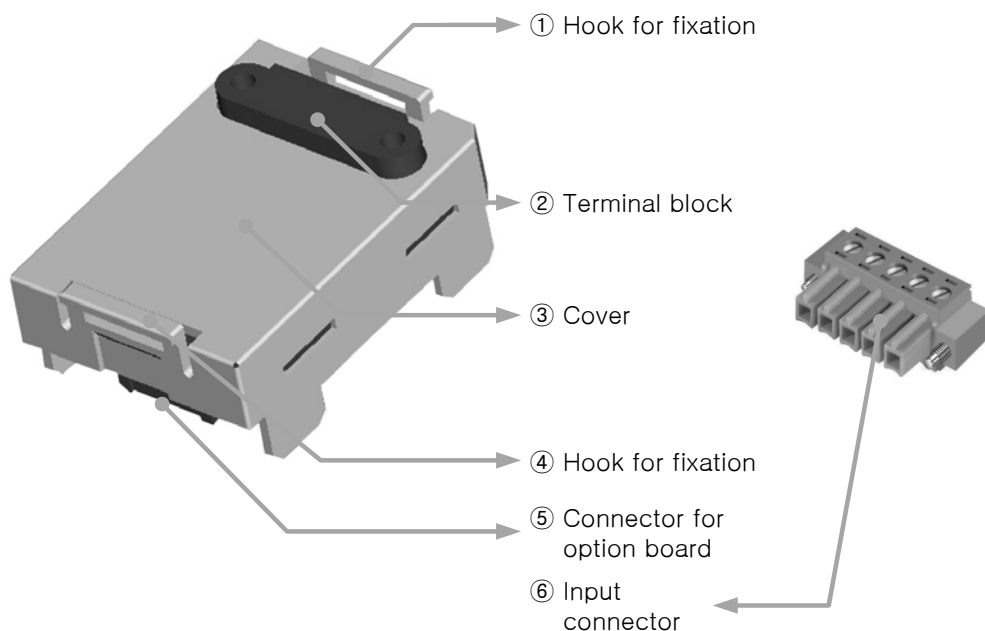

No.	Name	Description
①④	Hook for fixation	▶ Hook for fixing the option board to main unit
②	Terminal block	▶ Wiring terminal block to connect with external device (Analog input)
③	Cover	▶ Option board cover
⑤	Connector for option board	▶ Connection connector for connecting the option board to the main unit
⑥	Input connector	▶ Wiring connector for connecting with the external device

## 12.4 Characteristic of Thermocouple Temperature Conversion

Thermocouple input module connect 2 kinds of thermocouple directly, input characteristic are as described below.

(1) Thermocouple K (JIS C1602-1995): -200 °C(-5891 μV) ~ 1300 °C(52410 μV)

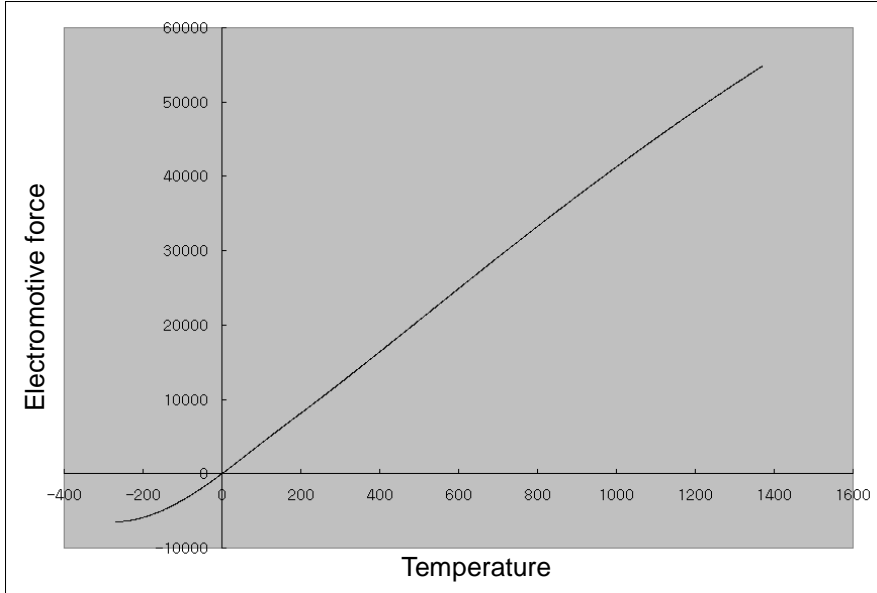

(2) Thermocouple J (JIS C1602-1995): -200 °C(-7890 μV) ~ 1200 °C(69553 μV)

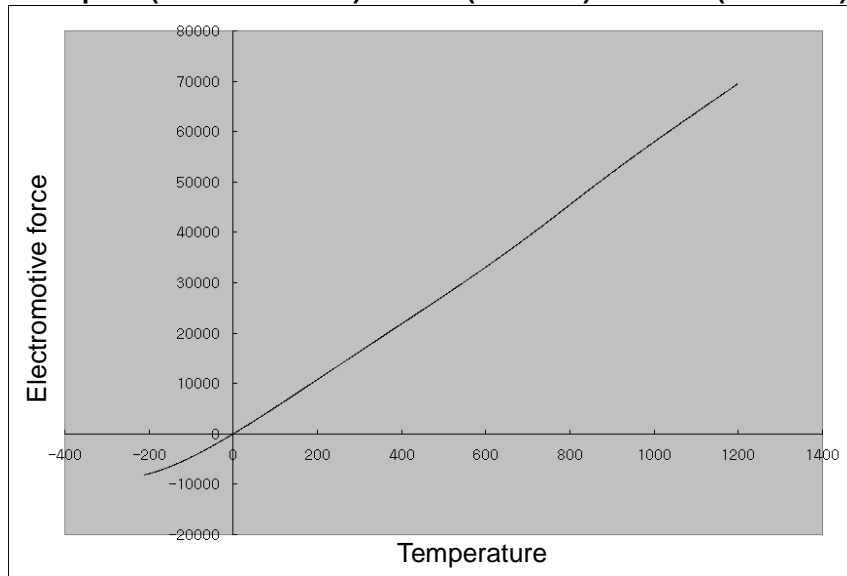

### Remark

Thermocouple characteristics: thermocouple sensor measures temperature by using fine voltage (electromotive force), which occurs when applying temperature gradient to a junction between two different metals.

The temperature-electromotive force relation specification of normal thermocouple sensor provides the electromotive force, which is measured when a sensor's measuring point is at 0 °C. On that account, when measuring temperature by using thermocouple sensor, cold junction compensation (reference junction compensation, RJC) is used. (built-in function of temperature measuring module).

## 12.5 Accuracy

Accuracy / Resolution are as follows according to ambient temperature

Thermocouple type	Measurement temperature range	Indication temperature range	Accuracy - note1)		Resolution
			Normal temperature (25 °C)	Operating temperature - note2) (0 °C ~ 55 °C)	
K	-200.0 °C ~ 1300.0 °C	-200.0 °C ~ 0.0 °C	±15.0 °C		0.2 °C
		0.0 °C ~ 1300.0 °C			0.1 °C
J	-200.0 °C ~ 1200.0 °C	-200.0 °C ~ -100.0 °C	±14.0 °C		0.2 °C
		-100.0 °C ~ 1200.0 °C			0.1 °C

Note1) Total accuracy (normal temp.) = accuracy (normal temp.) + cold junction compensation accuracy  
 = ±(full scale X 0.2% + 1.0 °C)

Cold junction compensation accuracy = ±1.0 °C

Note2) Temp. coefficient: ±100 ppm/°C

(1) When ambient temp. is normal (25 ± 5 °C): within the ±1% of entire measurement temp. range

(2) When ambient temp. is operating temp. (0 ~ 55 °C): within the ±1% of measurement temp. range

Ex.) When K type thermocouple is used and ambient temperature is normal.

In case of measuring 1000 °C temperature, output range of conversion data is

1000 °C - [{1300 - (-200)} x 1 %] - 1 ~ 1000 °C + [{1300 - (-200)} x 1 %] + 1

namely, 984.0 ~ 1016.0 [°C] 입니다.

### Note

- (1) For stabilization of measurement temperature, warming-up time more than 15 min. is necessary, after restart.
- (2) If ambient temperature changes rapidly, measurement temperature may change temporally. Keep the ambient temperature steady for stabilization of measuring temperature.
- (3) If wind of the cooling fan contacts with module directly in the panel, accuracy decreases. Do not contact with wind directly.

## 12.6 Conversion speed

### 12.6.1 Conversion speed function

- (1) Conversion speed: 50ms/2Ch
- (2) Sequential process method

The next channel is converted after conversion of one channel is completed.  
(Run/Stop of the respective channels can be set independently.)

- (3) Concept of conversion time

The time taken to convert the temperature from terminal block to digital value and save it at internal memory

∴ Processing time = less than 50ms + 6 x scan time

Example) PLC average scan time: 1 ms

When using all channels: conversion time = 50ms+6 X1ms = 56 ms

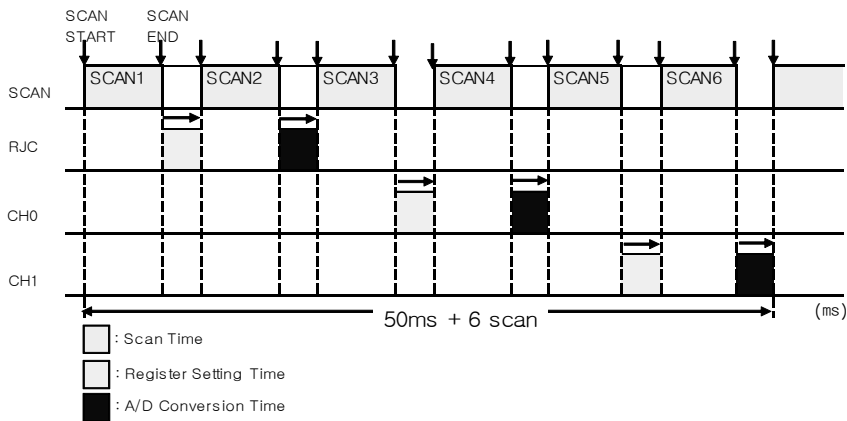

## 12.7 Conversion speed

### 12.6.1 Temperature Display function

- (1) The input temperature is converted to digital value down to the one decimal place.

Ex.) If the detected temperature is 123.4°C, its converted value to be saved to the internal memory will be 1234.

- (2) Temperature can be converted to Celsius or Fahrenheit scale temperature value as desired.

Ex) If Pt100 sensor is used, the temperature of 100.0°C can be converted to 2120 when Fahrenheit scale is used.

- Conversion °C to °F,  $F = \frac{9}{5}C + 32$
- Conversion °F to °C,  $C = \frac{5}{9}(F - 32)$

- (3) temperature input ranges of sensor are as follows;

- K Type : -200.0 ~ 1300.0°C (-328.0°F ~ 2372.0°F)
- J Type: -200.0 ~ 1200.0°C (-328.0°F ~ 2192.0°F)

## 12.8 Disconnection detection

### 12.8.1 Disconnection detection function

Thermocouple input module has a function that detects the disconnection and displays it. That the module detects and displays disconnection means that the following cabling path would have partially bad connection, which requires taking measures

- (1) If disconnection occurs between thermocouple or compensating cable and module, it generates error code.
- (2) Disconnection can be detected by channels. However, it is available for the only channel(s) designated for operation.

Thermocouple connection status	Channel run	Disconnection flag
Normal	Run	Off
	Stop	Off
Thermocouple disconnection	Run	On
	Stop	Off

- (3) In case disconnection occurs, disconnection flag of each channel will be turned on and in case disconnection is canceled, it will be turned off.

Disconnection flag	Contents
U0y.01.4	Ch. 0 disconnection
U0y.01.5	Ch. 1 disconnection

- (4) When disconnection occurs, the min value among indication temperatures is displayed

Type	Displayed temperature in case of disconnection
K type	-250.0℃
J type	-210.0℃

## 12.9 Disconnection detection

### 12.9.1 Average function

(1) Count average

It accumulates temperature conversion values of a selected channel as many as average value and displays the average of the total sum in digital data

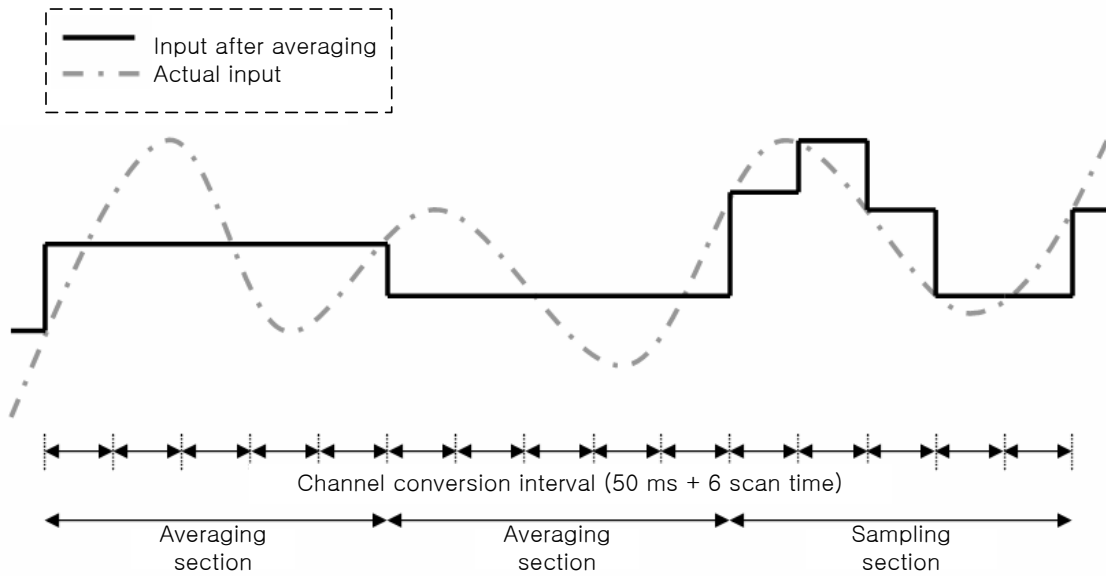

- Setting range = 2 ~ 64000 [times]

- Averaging interval is calculated according to the number of channel used

- Averaging interval[ms] = Averaging count x (50ms + 6 scan time)

#### Remark

(1) Averaging interval varies according to change of scan time.

## 12.10 Disconnection detection

### 12.10.1 Installation environment

Attention should be paid to the followings in order to secure the reliance and stability of the system.

#### (1) Environmental Conditions

- (a) Install on a water-proof and dust-proof control board.
- (b) Place free of continuous impact or vibration.
- (c) Place not directly exposed to direct sunrays.
- (d) Place where dew does not form due to rapid temperature change.
- (e) Place where ambient temperature is maintained between 0 - 55 °C.

#### (2) Installation Construction

- (a) In case of screw hole processing or wiring construction, wiring dregs should not go into PLC.
- (b) Install on a position easy to access.
- (c) Should not install on the same panel which high voltage device is installed on.
- (d) It should be 50mm and longer distant from duct and modules.
- (e) Should ground in the environment where is not interrupted from noise.
- (f) Install not to contact with cooling pan in the panel

#### (3) Cautions in handling

It describes caution in handling from unpacking module to installation.

- (a) Do not fall or apply excessive impact on it.
- (b) Never attempt to separate PCB from the case.
- (c) Make sure that any impurities including wiring dregs should not go into the upper part of module during wiring work.

### 12.10.2 Wiring

#### (1) Cautions in wiring

- (a) Do not place AC power line close to the AUX signal line of the module. To avoid surge or induced noise occurring from AC, make sure to leave a proper space.
- (b) Cable should be selected by considering ambient temperature and allowable current and the specification of cable should be as follows.

Cable specification	
Lower limit	Upper limit
0.18mm <sup>2</sup> (AWG24)	1.5 mm <sup>2</sup> (AWG16)

- (c) If cable is placed too close to any heating device or materials or if it directly contacts oil and similar materials for a long time, it may cause short-circuit, resulting in breakdown and malfunction.
- (d) Check the polarities during terminal strip wiring
- (e) Wiring with high voltage cable or power line may cause induction problem, causing malfunction or trouble.
- (f) External DC24V power should be same with power of XGB. If external DC24 V power of thermocouple input module is turned on/off while power of XGB main unit is on, temperature input value may have an error.
- (g) Thermocouple input module may use 4 types of thermocouple sensors. (K / J / T / R)



- (2) Terminal array  
Terminal array of thermocouple input module is as follows.

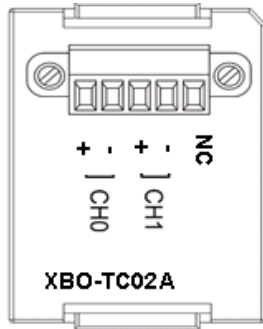

Signal name	Purpose
CH0 +	Channel 0 thermocouple input
CH0 -	
CH1 +	Channel 1 thermocouple input
CH1 -	
NC	Not used

- (3) Wiring example

Thermocouple can be connected with module directly. If point where temperature is measured is far from the module, use the compensating cable to connect  
(The compensating cables are different according to thermocouple type. For more information about the compensating cable, contact the producer of thermocouple.)

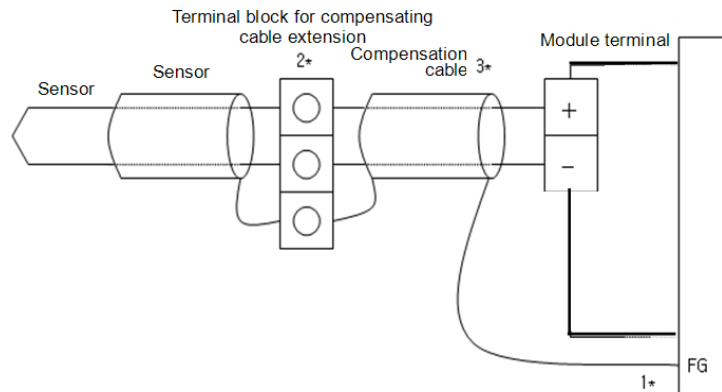

- 1) In case sensor and compensating cable are shielded, shield connection is possible to PLC FG terminal.
- 2) It is necessary to use extension terminal block of which material is kept at uniform temperature in order to reduce error.
- 3) Compensating cable should use the same type of sensor, which was used for measuring.

## 12.11 Operation Setting and Monitor

### 12.11.1 Operation Parameter Setting

Operation parameter of thermocouple input module can be set through [I/O Parameter] of XG5000

(1) Setting items

For user convenience, parameter setting of thermocouple input module is provided by GUI (Graphical User Interface) method in the XG5000. The items which can be set through [I/O Parameter] in the project window are as follows.

Items	Contents
[I/O Parameter]	(a) Sets the following items for operation of module. <ol style="list-style-type: none"> <li>1) Channel status (Disable / Enable)</li> <li>2) Sensor type (K / J)</li> <li>3) Filter setup (Filter constant)</li> <li>4) Averaging process (Count averaging)</li> </ol> (b) The parameter set by the user is saved in the flash memory of XGB main unit after download.

(2) How to use [I/O Parameter]

- (a) Execute the XG5000 and make the project.  
(For how to make the project, refer to the XG5000 user manual)
- (b) Double-click [I/O Parameter] on the project window.

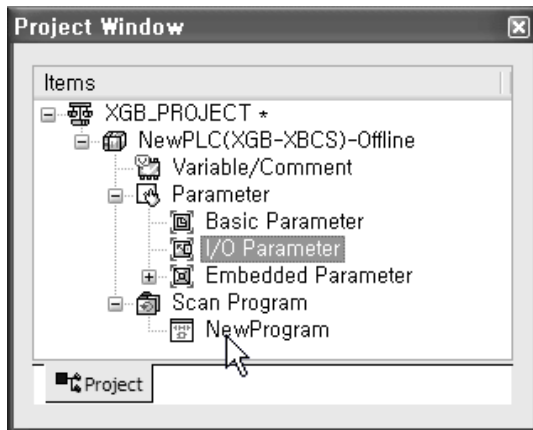

(c) If [I/O Parameter Setting] window shows, find slot of base where module is installed and click it

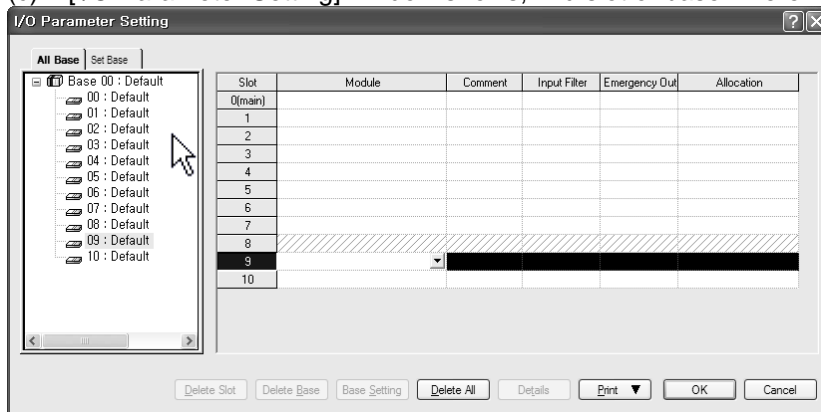

(d) Register the module on a slot where module is installed on as follows.

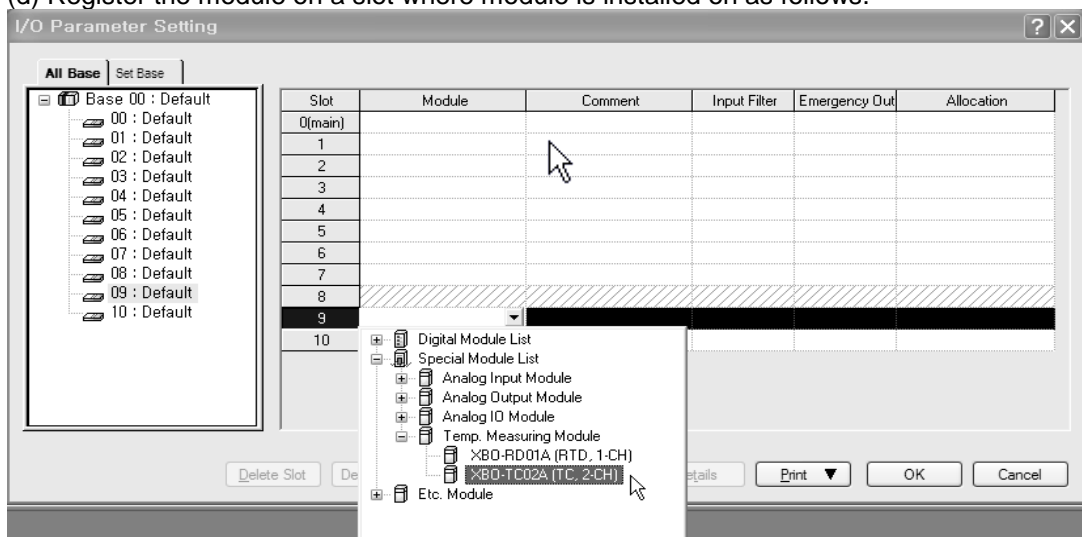

(e) Select a module and click [Details] or double-click a module for parameter setup.

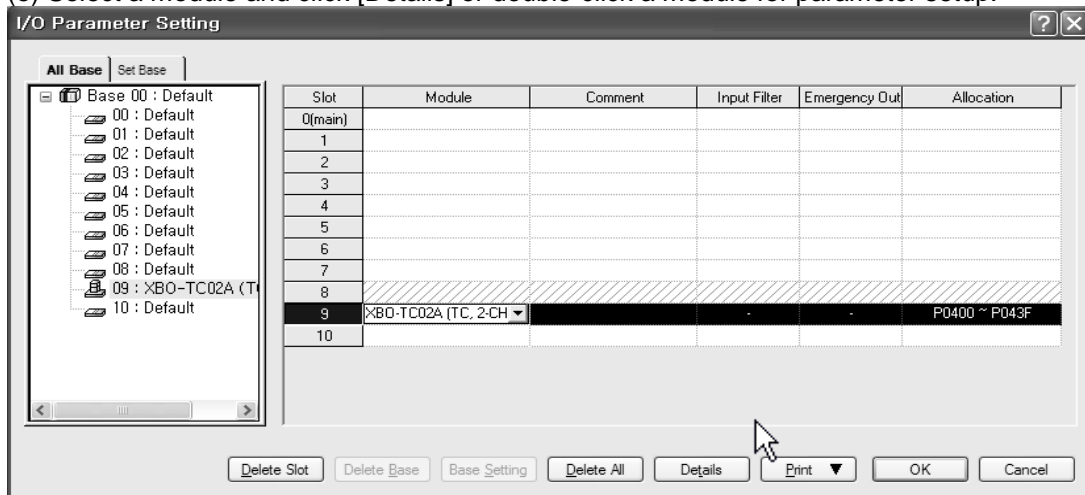

- (f) Parameter setup screen appears as follows. If you click the item you want to set, settable parameter will be displayed.

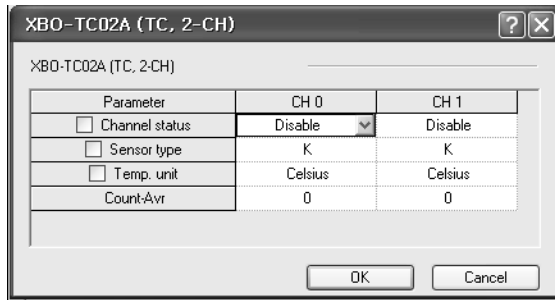

- (g) The initial values of each item are as figure shown below

1) Channel status (Disable / Enable)

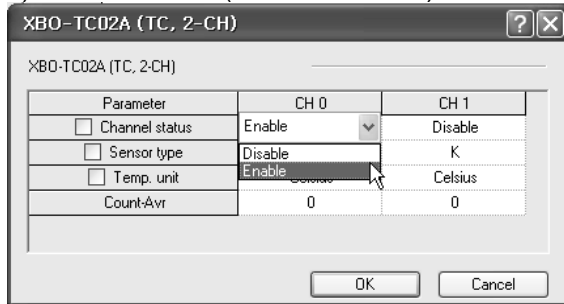

2) Sensor type (K / J)

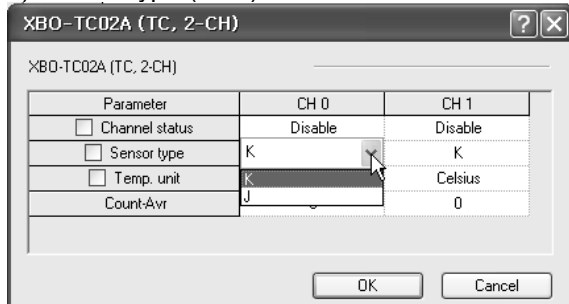

3) Temp. unit (Celsius / Fahrenheit)

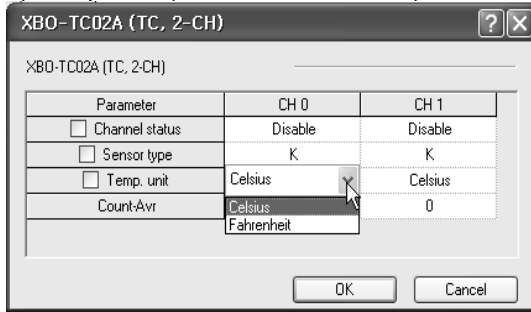

4) Average processing (Count averaging)

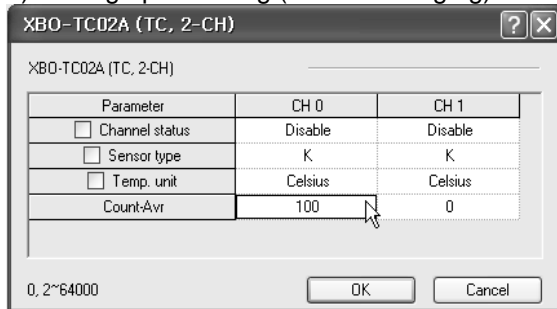

5) If you input invalid number, error message will be displayed.  
(When average value is out o range)

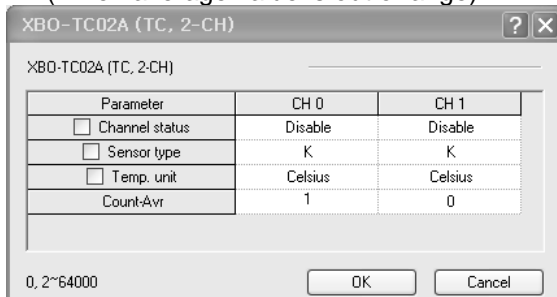

### 12.11.2 Special module monitoring function

While XG5000 is connected with PLC, through [Monitor] -> [Special Module Monitoring], the user can test the operation of the module.

**Remark**

- 1) If system resource is short, the screen may not be displayed properly. In case of this, shut down other application program and restart the XG5000.
- 2) On the [Special Module Monitoring] status, I/O parameter is set temporarily to execute the test. So if [Special Module Monitoring] status ends, I/O parameter is not saved.
- 3) By test function of [Special Module Monitoring], the user can check if analog module operates properly or not without any sequence program.

(1) How to use special module monitoring

(a) Start of [Special Module Monitoring]

While XG5000 is connected with PLC, start [Monitor] -> [Special Module Monitoring]. If that is not online status, [Special Module Monitoring] is not activated.

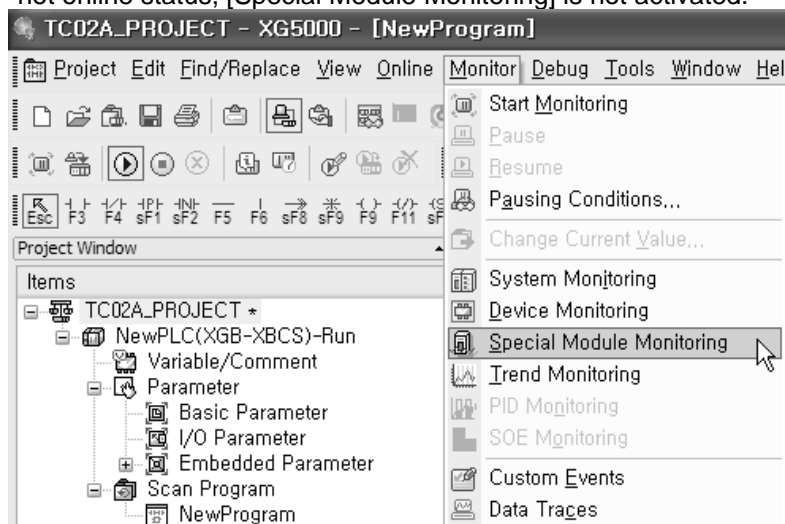

(b) How to use [Special Module Monitoring]

- 1) Click [Monitor] -> [Special Module Monitoring] while XG5000 is connected with PLC basic unit. 'Special Module List' screen is displayed as shown below and displays information of base/slot with special module type. On the list dialog box, the modules currently equipped at the PLC are displayed.

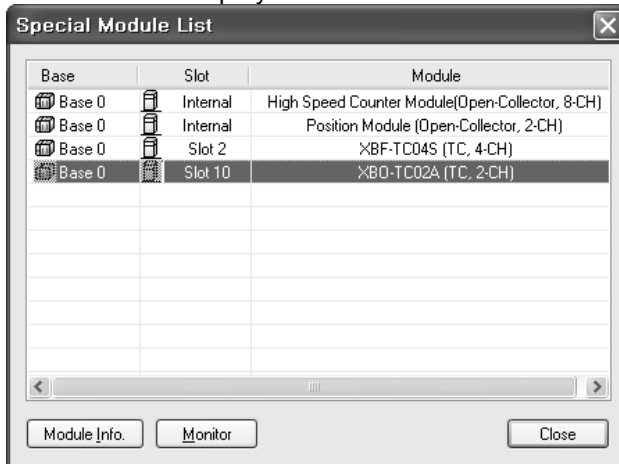

- 2) Clicking [Module Info.] shows the information of special module

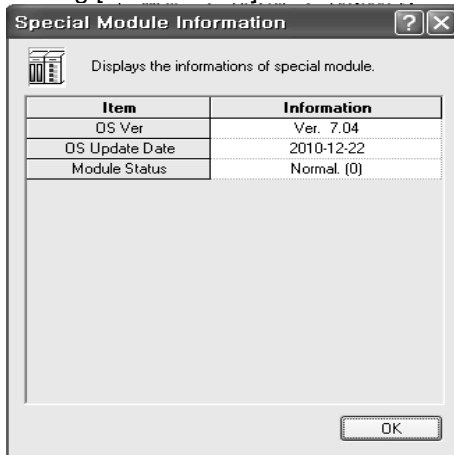

- 3) Clicking [Monitor] shows the following screen

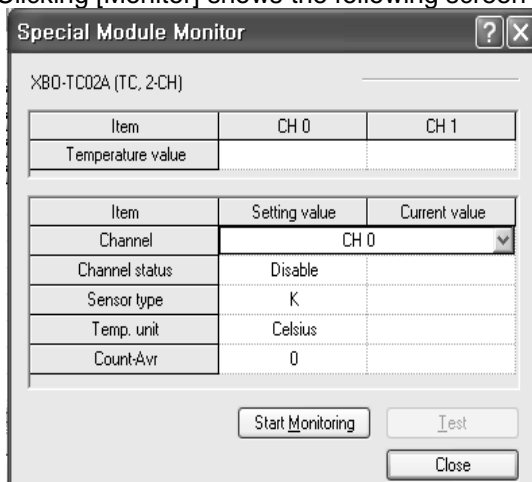

- 4) [Start Monitoring]: [Start Monitoring] button will show you digital input data of the operating channel. The figure below is monitoring screen when all channels are “Run” status.

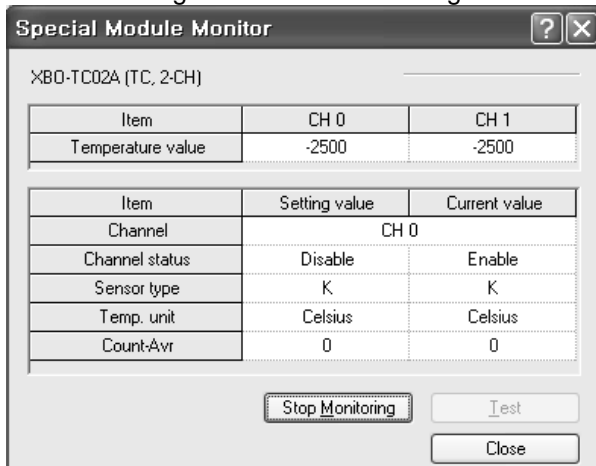

[Start Monitoring] execution screen

- 5) [Test]: [Test] is used to change the parameters of the Thermocouple input module. You can change the parameters when you click the values at the bottom of the screen. It is only available when XGB CPU unit's status is in [Stop].

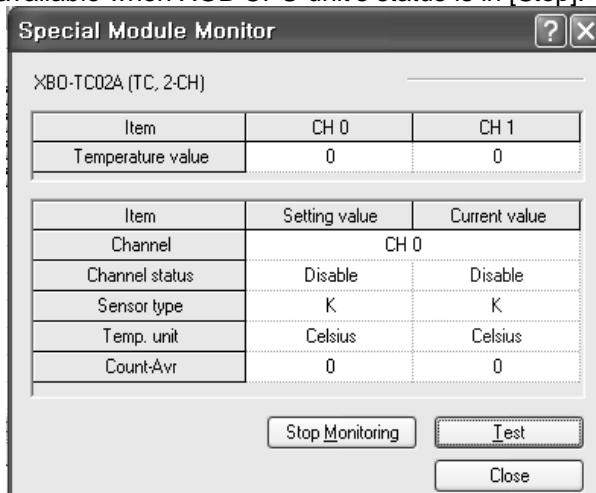

[Test] execution screen



### 12.11.3 Register U devices (Special module variable)

It registers the variables for each module referring to the special module information that is set in the I/O parameter. The user can modify the variables and comments.

(1) Procedure

(a) Select the special module type in the [I/O Parameter Setting] window.

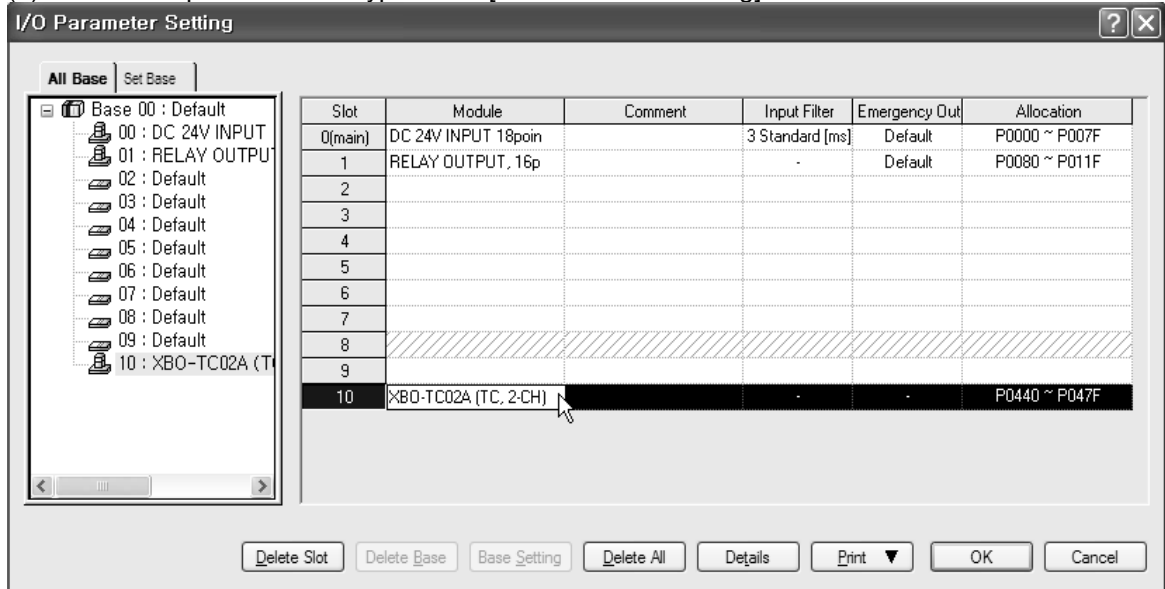

(b) Double click 'Variable/Comment' from the project window.

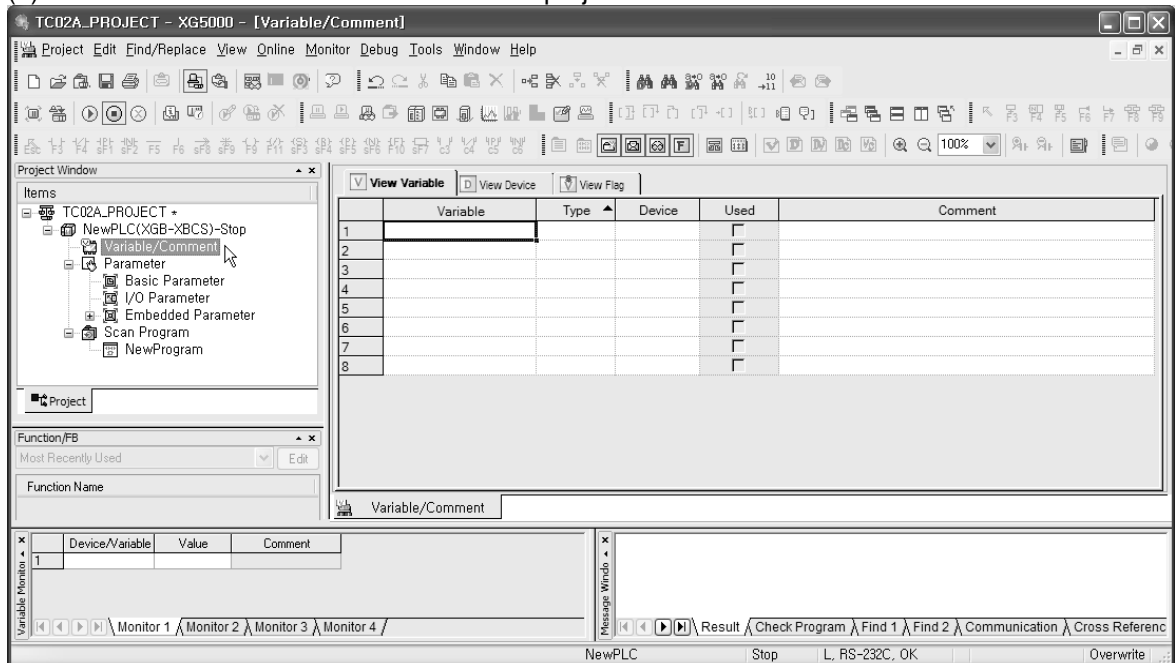

- (c) Select [Edit] – [Register U Device].  
 In case of XEC, select [Edit] - [Register special module variable]

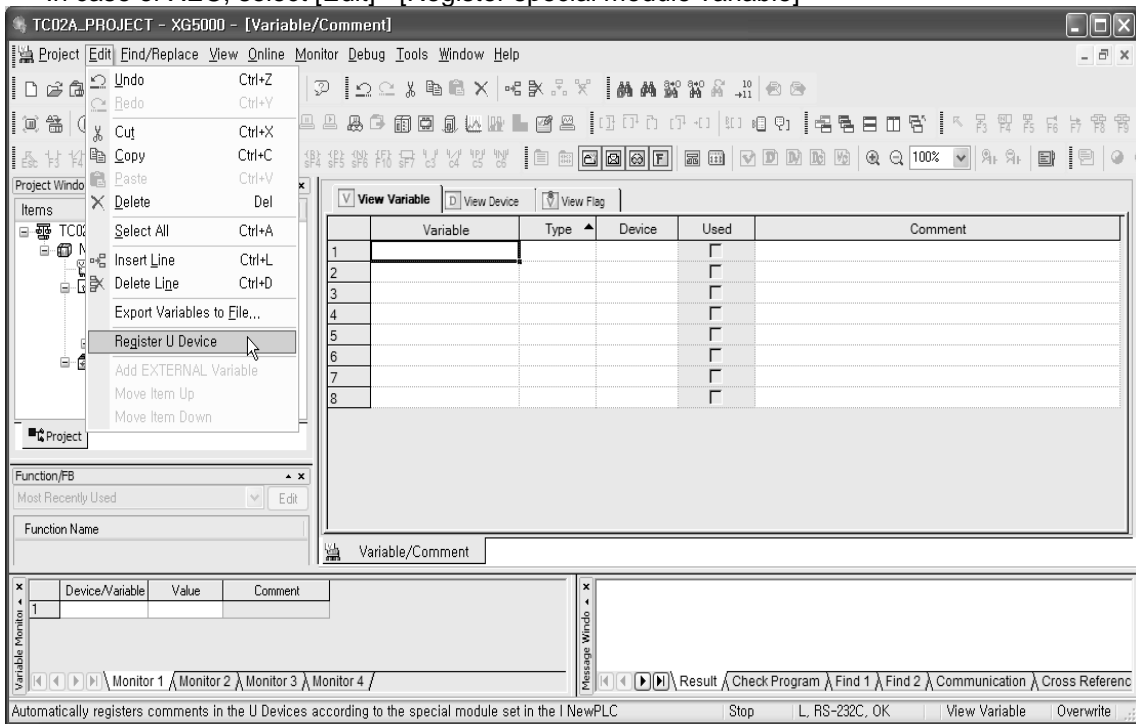

(d) If you click “yes”, U device will be registered automatically. At this time, if there is U device comment inputted previously, the previous comment will be removed.

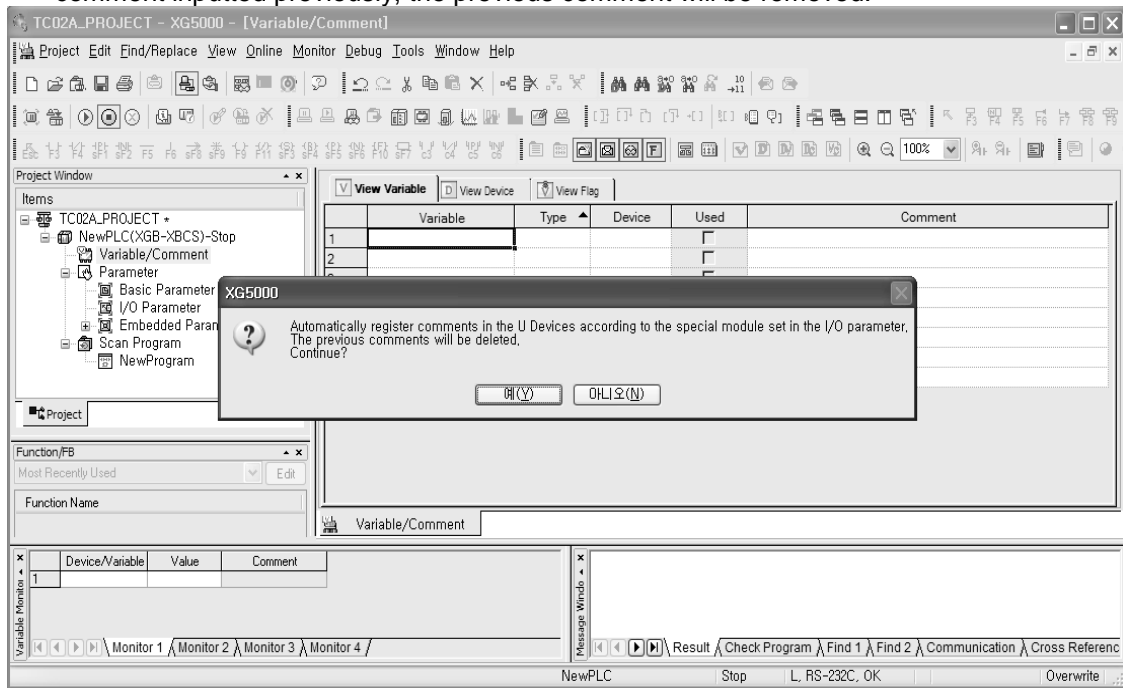

(e) As shown below, the variables are registered.

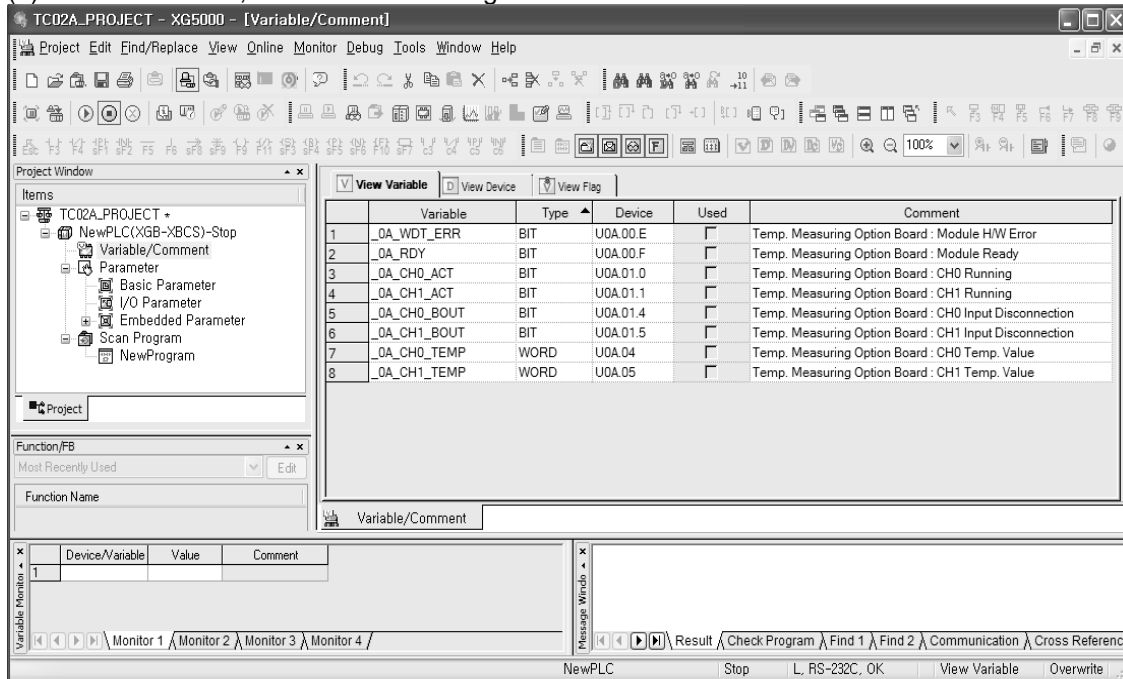

(2) Save variables

- (a) The contents of 'View Variable' can be saved as a text file.
- (b) Select [Edit] -> [Export to File].
- (c) The contents of 'View variable' are saved as a text

(3) View variables

(a) The example program of XG5000 is as shown below

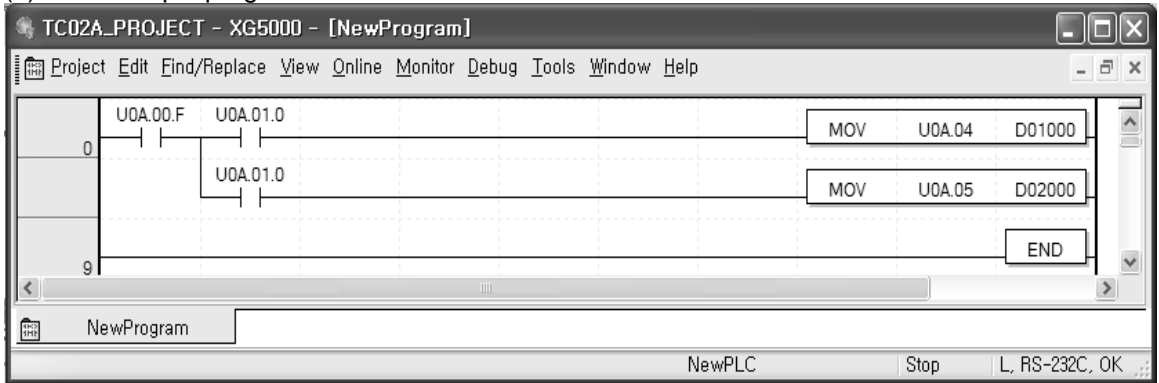

(b) Select [View] -> [Variables]. The devices are changed into variables.

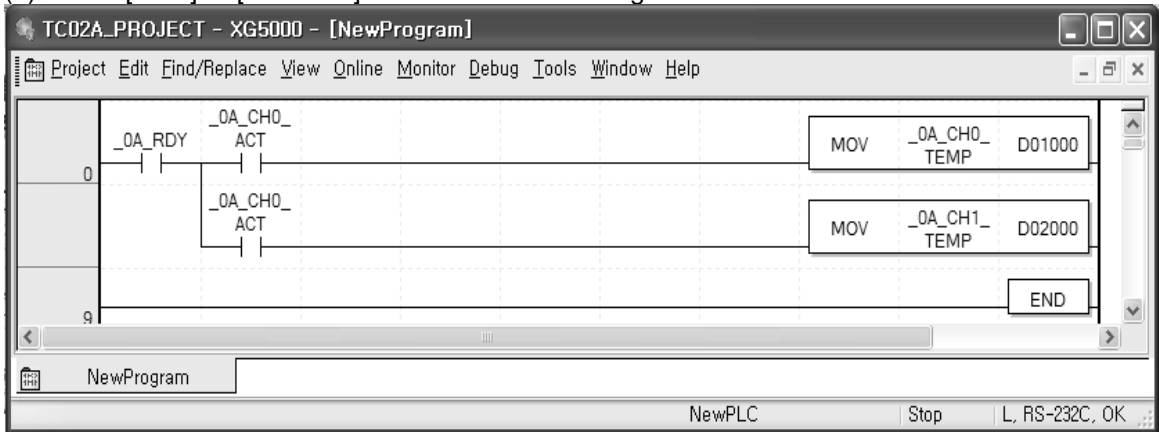

(c) Select [View] -> [Devices/Variables]. Devices and variables are both displayed

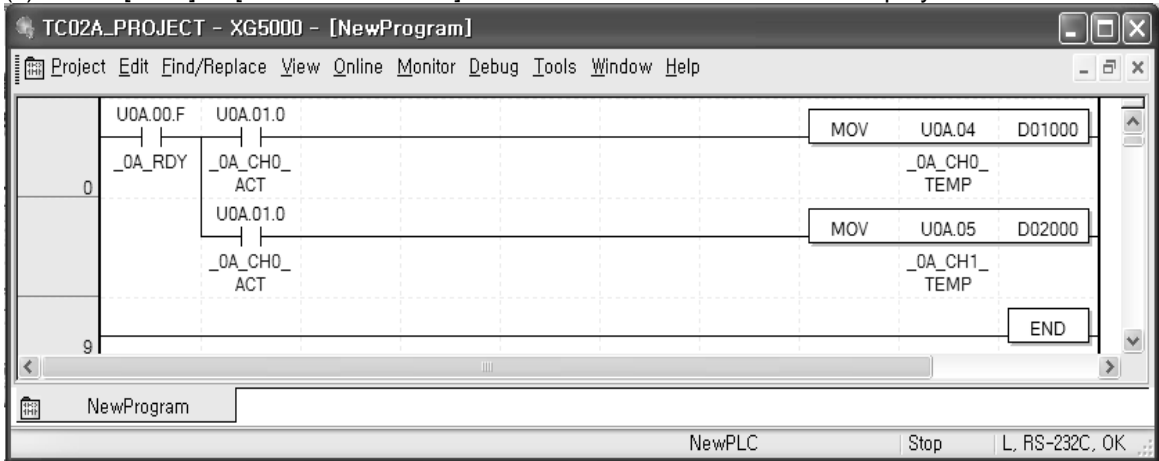

(d) Select [View] -> [Device/Comments]. Devices and comments are both displayed.

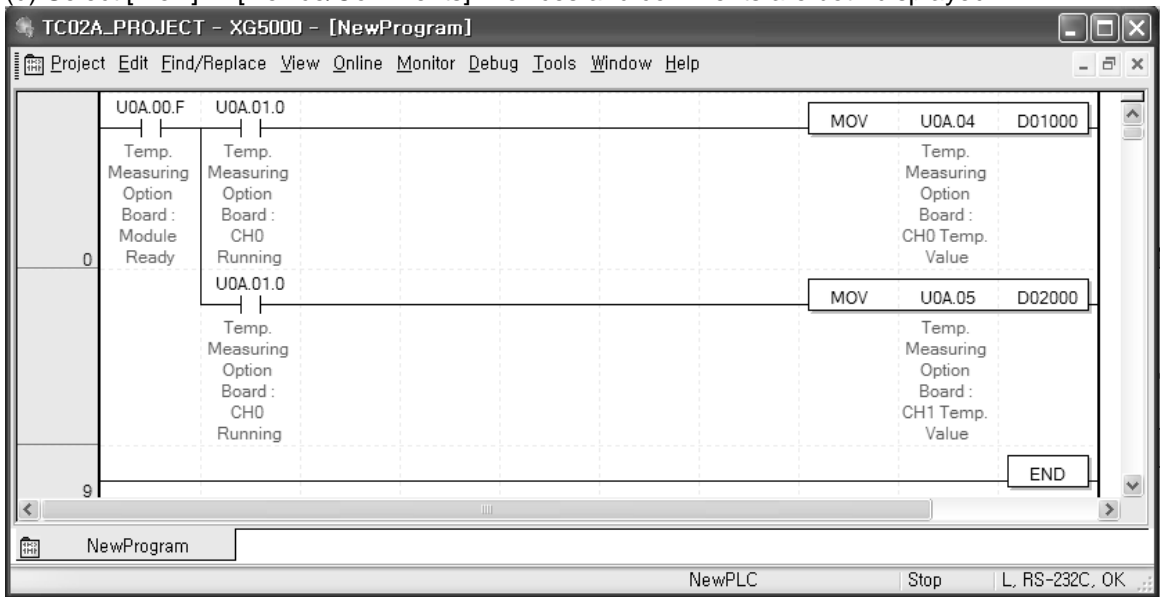

## 12.12 Configuration and Function of Internal Memory

It describes the configuration and function of internal memory

### 12.12.1 Data I/O area (U device)

(1) Data sent from module to XGB main unit (XGB PLC input area, read only)

Device assignment	Type	Device assignment		Comment	R/W	Signal direction
		XBC	IEC			
_0y_ERR	BIT	U0x.00.E	%UX0.y.14	Module H/W error	R	TC02A→CPU
_0y_RDY	BIT	U0x.00.F	%UX0.y.15	Module Ready	R	
_0y_CH0_ACT	BIT	U0x.01.0	%UX0.y.16	CH 0 running	R	TC02A→CPU
_0y_CH1_ACT	BIT	U0x.01.1	%UX0.y.17	CH 1 running	R	
_0y_CH0_BOUT	BIT	U0x.01.4	%UX0.y.20	CH 0 disconnection	R	
_0y_CH1_BOUT	BIT	U0x.01.5	%UX0.y.21	CH 1 disconnection	R	
_0y_CH0_TEMP	WORD	U0x.04	%UW0.y.4	CH 0 temp. conversion value	R	TC02A→CPU
_0y_CH1_TEMP	WORD	U0x.05	%UW0.y.5	CH 1 temp. conversion value	R	

- In the device allocation, the small letter 'y' is the No. of the slot where the module is installed.
- For example, to read the 'CH0 Temperature Value' of the TC module installed in the slot 9, write in U09.05. (%UW0.9.4 for IEC types)

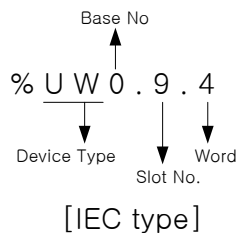
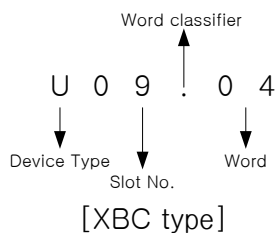

(2) Writing operation parameters through program (PUT instruction is used.)

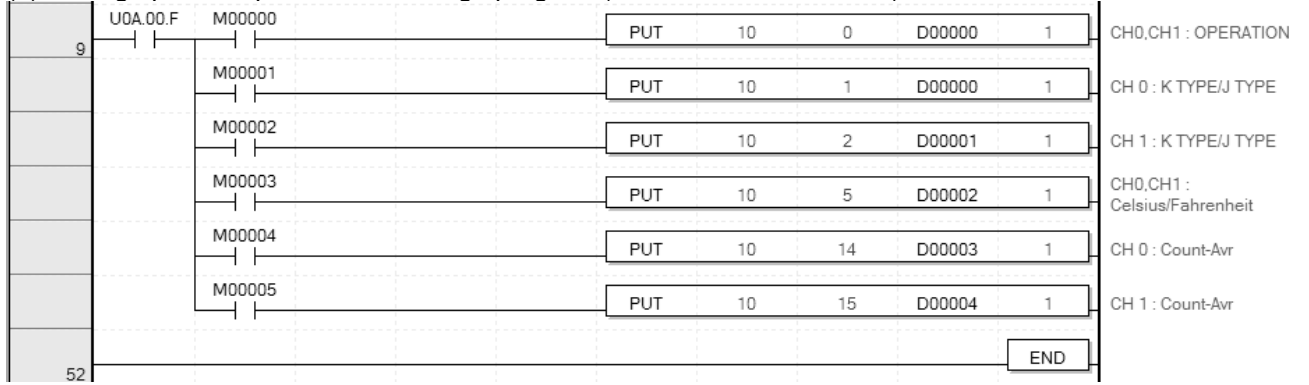

**Remark**

How to use PUT instruction

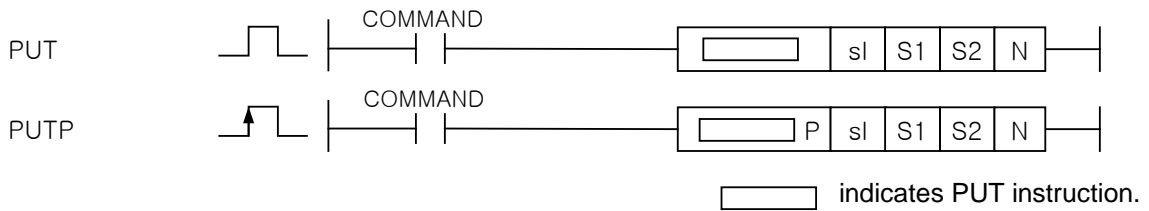

[Area setting]

Operand	Description	Data size
sl	Slot no. where special module is mounted	WORD
S1	Internal memory address of special module	WORD
S2	Device to save in special module	WORD
N	The number of data	WORD

### 12.12.2 How to set operation parameter

Operation parameter of thermocouple input module can be set by two methods.

- (1) Setting operation parameters through [I/O parameter setting] window.

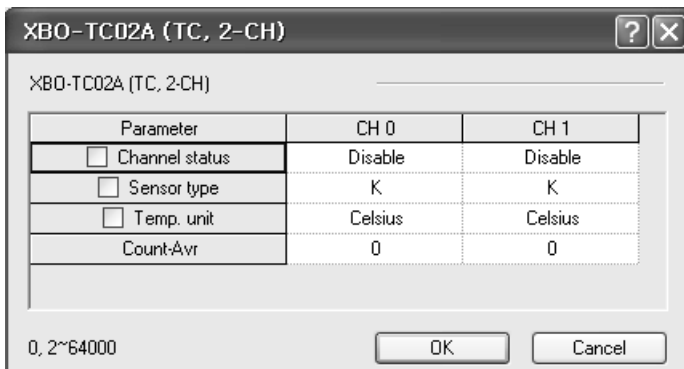



12.12.3 Operation parameter setting area

It describes operation parameter setting area of thermocouple input module.

Memory address		Description	Setting value	R/W	Instruction
Hex.	Dec.				
00 <sub>H</sub>	0	Designate a channel to use	bit0: bit3, 0: stop, 1: run	R/W	PUT/GET
01 <sub>H</sub>	1	Set sensor type of CH 0	K:0, J:1	R/W	
02 <sub>H</sub>	2	Set sensor type of CH 1			
05 <sub>H</sub>	5	Designate temperature metric system	bit0: bit3, 0: Celsius, 1: Fahrenheit	R/W	
0E <sub>H</sub>	14	CH0 average value	Count average: 2~64000 times	R/W	
0F <sub>H</sub>	15	CH1 average value			
10 <sub>H</sub>	16	Error information	10#: sensor type setting error 20#: count average value setting error	R	GET
11 <sub>H</sub>	17	Cold junction compensation temp.	Measured value of cold junction compensation temp.	R	GET
12 <sub>H</sub> ~18 <sub>H</sub>	18 ~24	System area (Offset gain storage area)	Read/Write unavailable	unavailable	-

**Remark**

 Warning (1) System area (Offset gain storage area) is area where Read/Write is unavailable. If this area changes, malfunction or breakdown may occur.

**(1) Designating Channel (Address 0)**

- (a) Temperature conversion module Enable/Disable can be set to each channel.
- (b) By prohibiting a channel not to use from conversion, conversion interval by channels can be shortened.
- (c) If channel to use is not designated, every channel can not be used.
- (d) In case of using PUT instruction, temperature conversion module Enable/Disable are as follows.

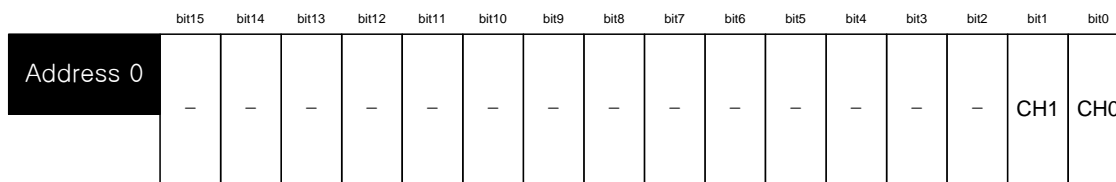

Channel status  
 Bit On (1): Enable  
 Bit Off (0): Disable

Bit	Description
0	Stop
1	Run

- (e) Values set in B4 ~ B15 are ignored.
- (f) This area shows the same results with "Channel status" in I/O parameter setting window.

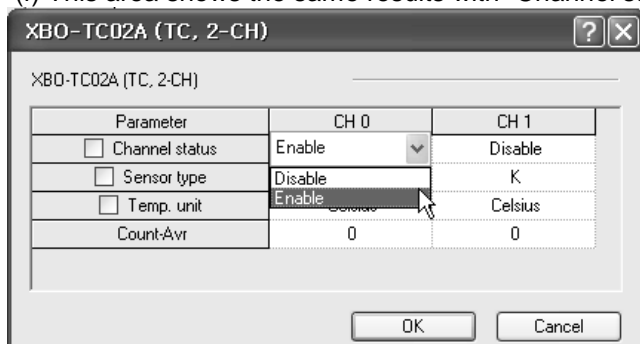

**(2) Sensor type setting area (Address 1~2)**

- (a) Sets sensor type with the following code.

Word	Sensor type
0	K
1	J

- (b) When input value is larger than 2, 0 (K type) is selected by force
- (c) In case of using PUT instruction, Sensor Type Setting Area is as follows.

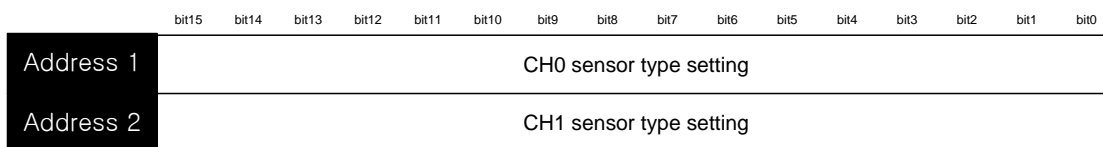

- (d) Values set in B8 ~ B15 are ignored.
- (e) This area shows the same results with sensor type designation in I/O parameter setting window.

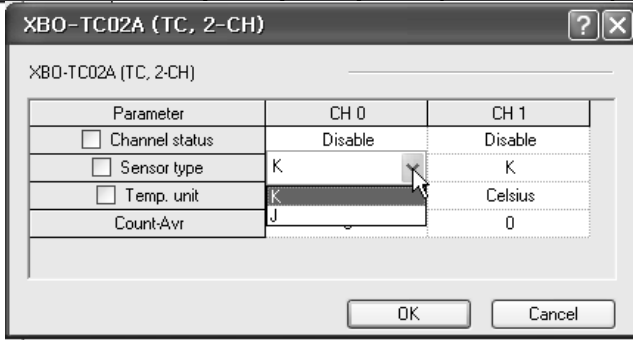

**(3) Temp. unit setting area (Address 5)**

- (a) Temp. unit (Celsius/ Fahrenheit) of thermocouple input module can be set per channel.
- (b) In case of PUT instruction, Temp. unit setting area is as follows.

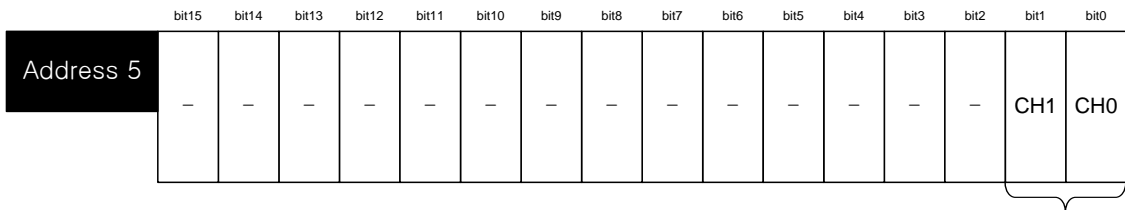

Temp unit setting  
0: Celsius  
1: Fahrenheit

Bit	Description
0	Celsius
1	Fahrenheit

- (c) Values set in B2 ~ B15 are ignored.
- (d) This area shows the same results with temp. unit setting in I/O parameter setting window.

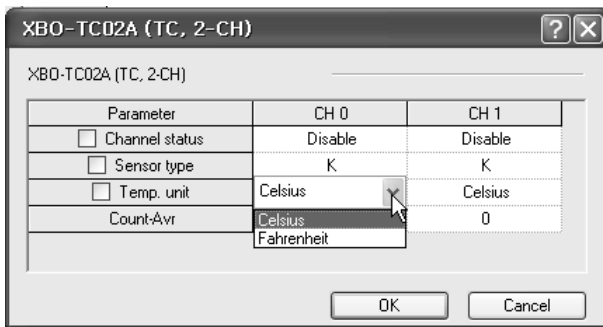

**(4) Average value setting area (Address 14~15)**

- (a) Average value can be set per channel.
- (b) If count average value is set as 0, averaging process is not applied and sampling-processed thermocouple input value is outputted.
- (c) In case of using PUT instruction, average value setting address is as follows.



- (d) This area shows the same results with count average value setting in I/O parameter setting window.
- (e) In the I/O parameter setting window, prohibition function is provided not to set value that is out of range. (In case of setting value that is out of range, error message is displayed.)

1) Count-Avr. setting

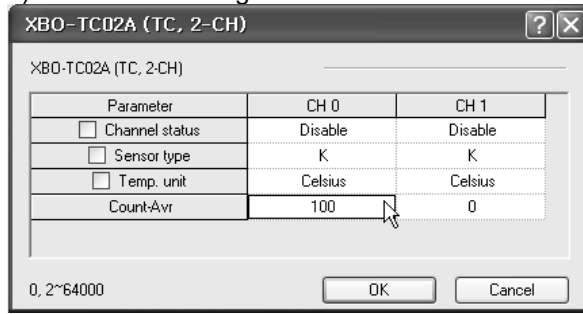

(5) Setting error information area (Address 16)

- (a) Saves error code detected at setup by the program
- (b) Setting error is canceled when invalid setting is corrected by resetting
- (c) When U0X.01.8~ U0X.01.9 (setting error flag) is on, you can cancel the error by checking this area and resetting
- (d) In case of GET instruction, setting error information address is as follows.

bit15	bit14	bit13	bit12	bit11	bit10	bit9	bit8	bit7	bit6	bit5	bit4	bit3	bit2	bit1	bit0
Address 16 CH0, 1 setting error information															

Type	Error code	Description	Priority	Remark
Setting error	10#	Input sensor type setting error	1	# means channel number Input channel 0,1
	20#	Input count average value range setting error	2	

- (e) If there are more than one errors, error code having higher priority will be saved.

(10) Cold junction compensation temp. area (Address 17)

- (a) Cold junction compensation temp. can be seen per channel.
- (b) In case of GET instruction, cold junction compensation temp. area is as follows.

bit15	bit14	bit13	bit12	bit11	bit10	bit9	bit8	bit7	bit6	bit5	bit4	bit3	bit2	bit1	bit0
Address 17 CH0,1 cold junction compensation temp.															

(11) System area (offset gain storage area: address 18~24)

- (a) In the system area (18~24: offset gain storage area), Read/Write is unavailable

	<b>Caution</b>	If the user changes this area, it may cause malfunction or breakdown. So do not handle this area.
--	----------------	--

## 12.13 Example Program

- (1) It describes how to set operation parameter.
- (2) The initial settings are saved in the internal memory of thermocouple module
- (3) The following is program example that reads the temp. value of thermocouple input module of slot 1 and check whether disconnection occurs or not.

### 12.13.1 Example using [I/O Parameter]

(1) I/O parameter setting window

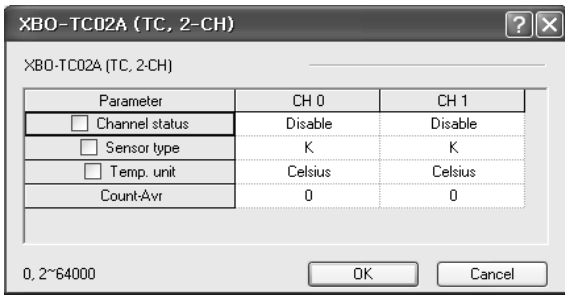
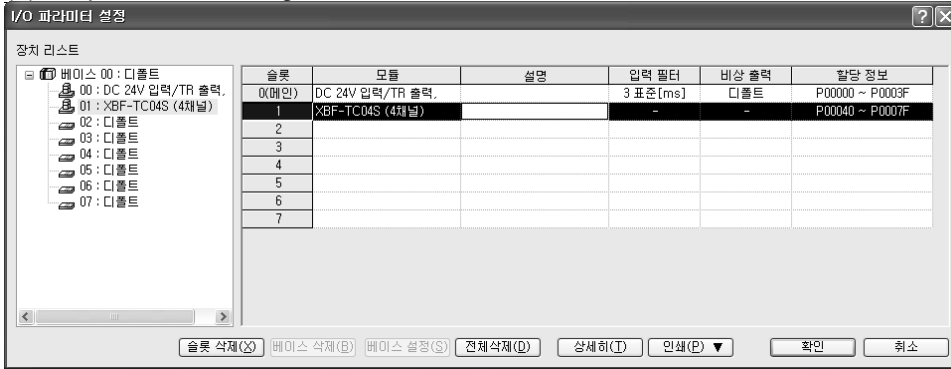

(2) Program example

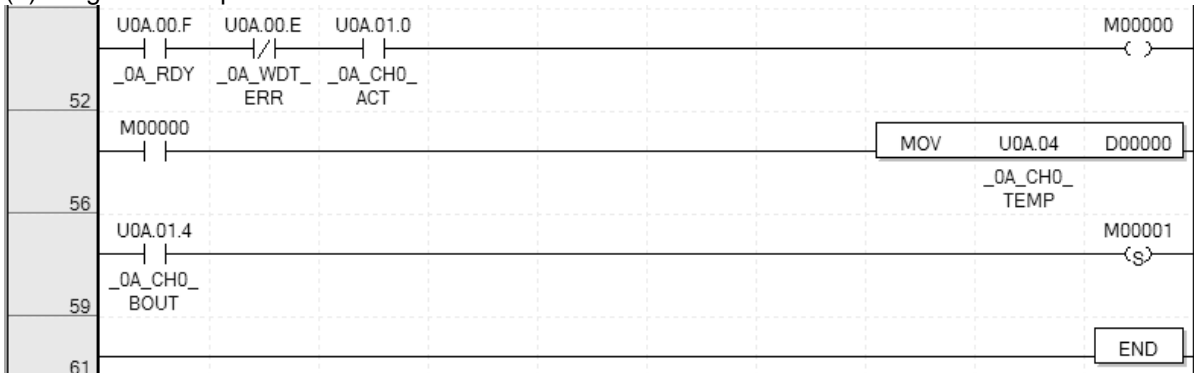

- (a) If module is under normal operation, M0000 is on.  
 U0A.00.F(module Ready) = On  
 U0A.00.E(module H/W error) = Off  
 U0A.01.0(CH0 running) = On
- (b) If M0000 is on, temp. conversion value (U0A.04) of CH0 moves to D0000.
- (c) If disconnection error occurs at CH0, U0A.01.4 (CH0 disconnection) is on and M0001 bit is set.

12.13.2 Program example using PUT/GET instruction

(1) Program example (XBC Type)

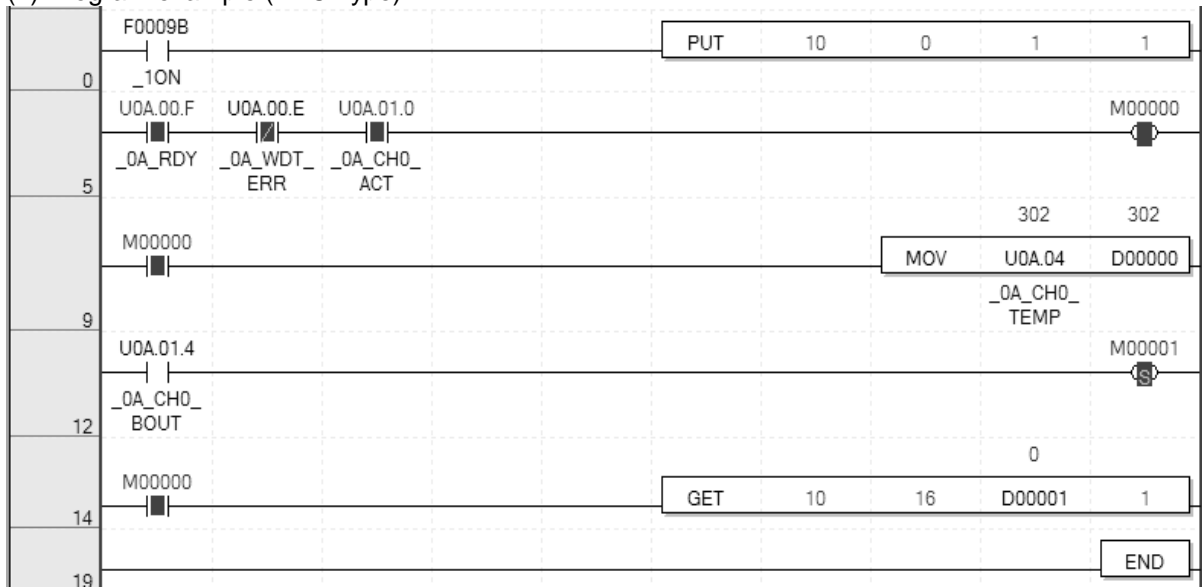

- (a) It writes h0001 at address 0 of slot 1 in order to enable CH0 by using PUT instruction.
- (b) If module is under normal operation, M0000 is on.  
 U0A.00.F(Module Ready) = On  
 U0A.00.E(Module H/W error) = Off  
 U0A.01.0(CH 0 running) = On
- (c) If M0000 is on, temp. conversion value of CH0 moves to D0000.  
 Current temp. conversion value, 278(27.8°C<sup>2</sup>) is saving in U0A.04.
- (d) If disconnection error occurs at CH0, U0A.01.4 (CH0 disconnection) is on and M0001 bit is set.
- (e) If M0000 is on, setting error (address 16) of CH0 moves to D0001. Since setting error (address 16) of CH0 is 0, there is no setting error.

(2) Program example (IEC Type)

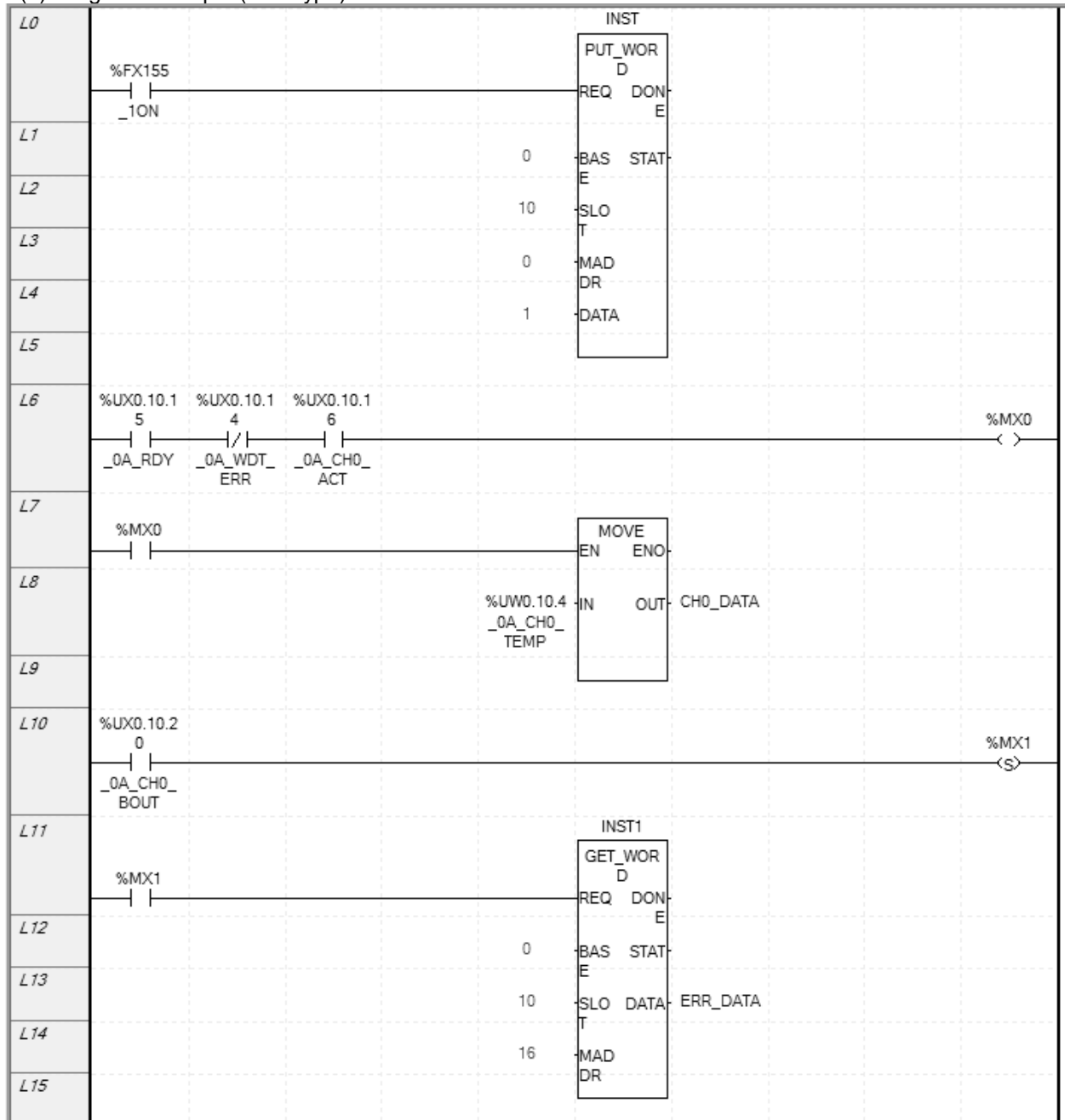

- (a) It writes 1 at address 0 of slot 1 in order to enable CH0 by using PUT instruction.
- (b) If module is under normal operation, %MX0 is on.  
 %UX0.10.15 (Module Ready) = On  
 %UX0.10.14 (Module H/W error) = Off  
 %UX0.10.16 (CH 0 running) = On
- (c) If M0000 is on, temp. conversion value of CH0 moves to CH0\_DATA.  
 Current temp. conversion value, CH0 Temp Value(%UW0.10.4) is saving in CH0\_DATA.
- (d) If disconnection error occurs at CH0, %UX0.10.20 (CH0 disconnection) is on and %MX1 bit is set.
- (e) If %MX0 is on, setting error (address 16) of CH0 moves to ERR\_DATA. Since setting error (address 16) of CH0 is 0, there is no setting error.

12.13.3 Example when error occurs

(1) Program Example

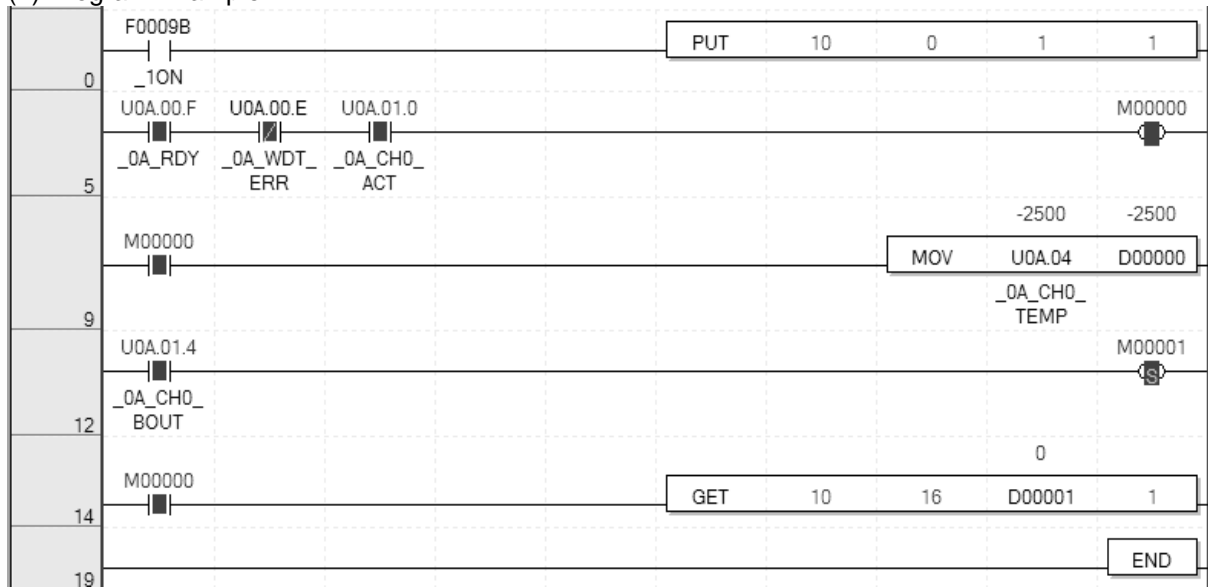

- (a) If disconnection error occurs at CH0, U0A.01.4 (CH0 disconnection) is on and M0001 bit is set
- (b) If disconnection error occurs at CH0, min. value within the range of K type temperature sensor is displayed at U01.04.
- (c) It is monitored as follows according to monitor display type.  
When monitoring the temp. conversion value, select "Unsigned Decimal".

Monitor display type	Display content
Unsigned Decimal	63036
Signed Decimal	-2500 (-250.0℃)
Hexadecimal	hF63C
As Instruction	63036



## 12.14 Troubleshooting

The chapter describes diagnostics and measures in case any trouble occurs during use of thermocouple input module.

### 12.14.1 Status in case of error

You can check whether there is error or not according to the module status.

Items	Normal	Disconnection	Module H/W error (Heavy error)
Operation	Normal operation Every function works	Normal operation Min. temp. is displayed	Module function stops
Measure	-	Checking sensor wiring	Customer service

### 12.14.2 Stats check of module

Module type, module information, O/S version and module status of thermocouple input module can be checked through XG5000 system monitoring function.

(1) Execution sequence

Two routes are available for the execution.

(a) [Monitor] -> [System Monitoring] -> And on the module screen, click the right mouse button to display [Module Information].

(b) [Monitor] -> [System Monitoring] -> And Double-click the module screen.

(2) Module information

(a) Module type: shows the information of the module presently installed.

(b) Module information: shows the O/S version information of module.

(c) O/S version: shows the O/S prepared date of module.

12.14.3 Troubleshooting

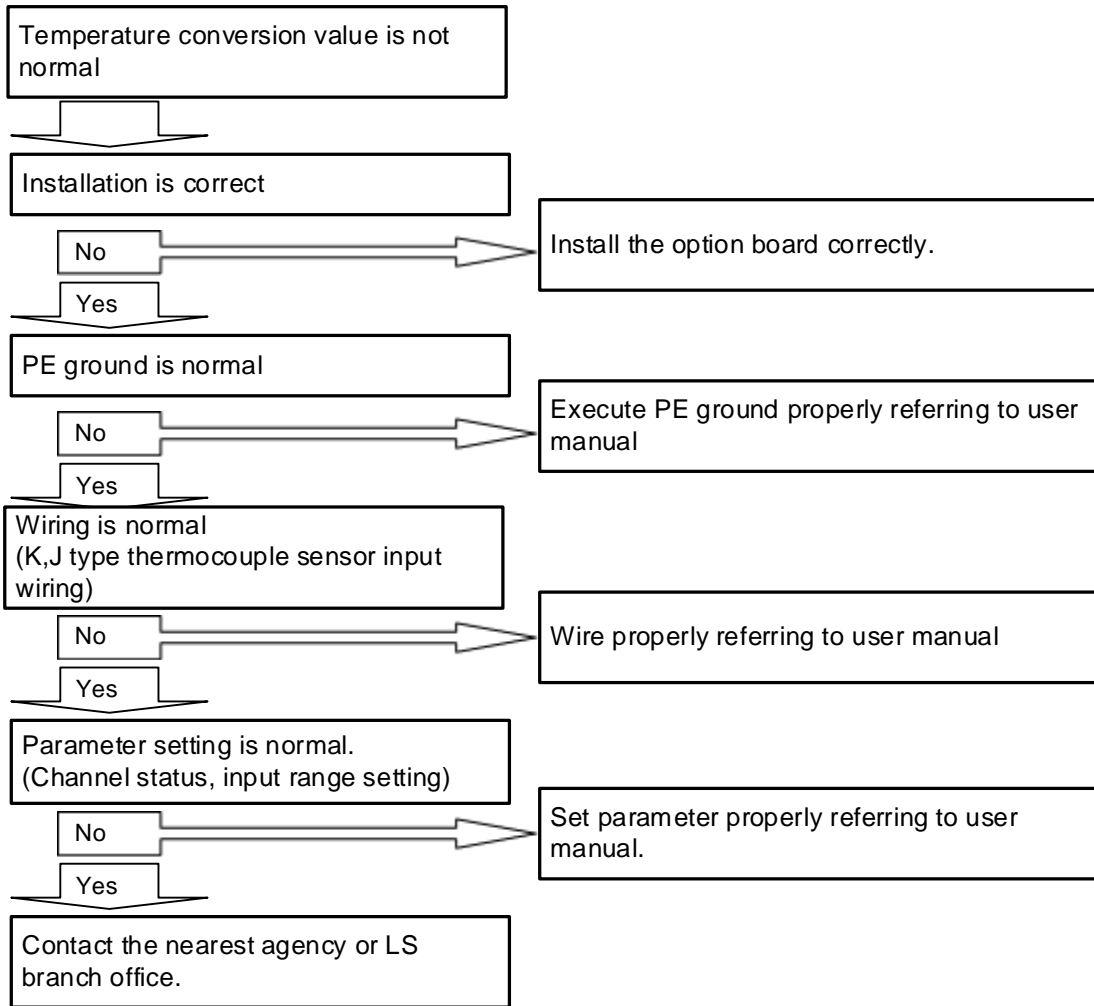

**13.1 Setting Sequence before Operation**

Before using the analog input module, follow steps below.

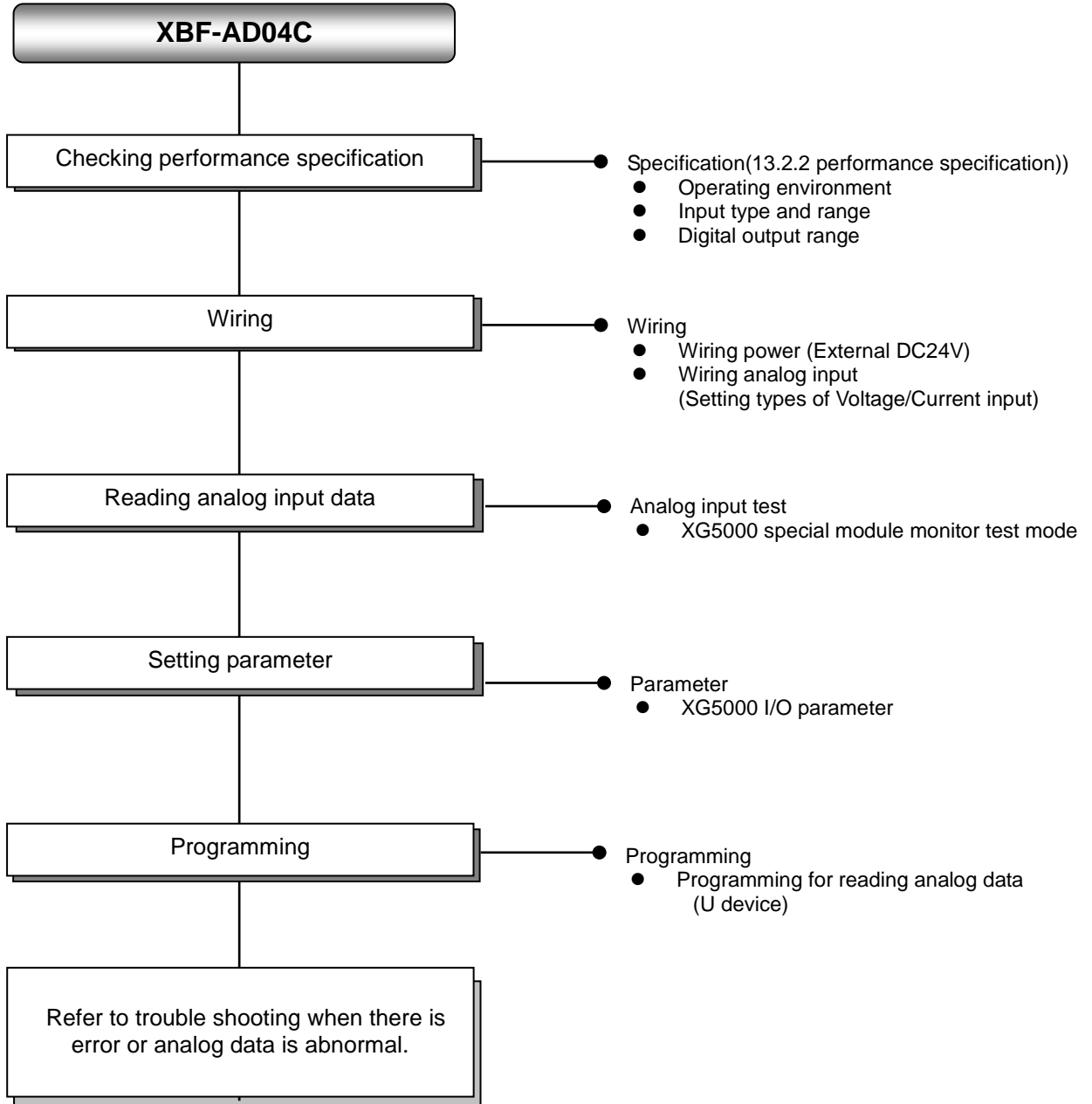

## 13.2 Specifications

### 13.2.1 General specifications

General specifications are as follows.

No.	Item	Specifications	Related specifications			
1	Ambient temperature	0°C ~ +55°C	-			
2	Storage temperature	-25°C ~ +70°C	-			
3	Ambient humidity	5 ~ 95%RH (Non-condensing)	-			
4	Storage humidity	5 ~ 95%RH (Non-condensing)	-			
5	Vibration resistance	Occasional vibration			-	-
		Frequency	Acceleration	Amplitude	How many times	
		5 ≤ f < 8.4 Hz	-	3.5 mm	10 times each directions (X, Y and Z)	
		8.4 ≤ f ≤ 150 Hz	9.8 m/s <sup>2</sup> (1G)	-		
		For continuous vibration				
		Frequency	Acceleration	Amplitude		
		5 ≤ f < 8.4 Hz	-	1.75 mm	IEC61131-2	
8.4 ≤ f ≤ 150 Hz	4.9 m/s <sup>2</sup> (0.5G)	-				
6	Shock resistance	<ul style="list-style-type: none"> <li>Peak acceleration: 147 m/s<sup>2</sup>(15G)</li> <li>Duration: 11ms</li> <li>Half-sine, 3 times each direction per each axis</li> </ul>	IEC61131-2			
7	Noise resistance	Square wave Impulse noise	AC: ± 1,500V DC: ± 900V		LSIS standard	
		Electrostatic discharge	Voltage : 4kV (contact discharging)		IEC 61131-2, IEC 61000-4-2	
		Radiated electromagnetic field noise	80 ~ 1,000 MHz, 10V/m		IEC 61131-2, IEC 61000-4-3	
		Fast transient /bust noise	Segment	Power supply module	Digital/analog input/output communication interface	IEC 61131-2, IEC 61000-4-4
Voltage	2kV	1kV				
8	Environment	Free from corrosive gasses and excessive dust	-			
9	Altitude	Up to 2,000 ms	-			
10	Pollution degree	Less than equal to 2	-			
11	Cooling	Air-cooling	-			

13.2.2 Performance specifications

Performance specifications are as follows.

Items		Performance specification		
Number of channels		4 channels		
Analog input	Type	Voltage	Current	
	Range	DC 1 ~ 5V DC 0 ~ 5V DC 0 ~ 10V DC -10 ~ 10V (Input resistance: 1 MΩ min)	DC 4 ~ 20mA DC 0 ~ 20mA (Input resistance: 250 Ω)	
	Current input or Voltage input can be selected through the external terminal wiring setting. ▶ In voltage mode, use V+ and COM terminal for the channel. In current mode, short V+ and COM terminal and then use I+ and COM terminal.			
Digital output	Type	16 bit binary data (Data : 14Bit)		
	Range	Unsigned value	0 ~ 16,000	
		Signed value	-8,000 ~ 8,000	
		Precise value	1,000 ~ 5,000 (1 ~ 5V) 0 ~ 5,000 (0 ~ 5V) 0 ~ 10,000 (0 ~ 10V) -10,000 ~ 10,000 (±10V)	4,000 ~ 20,000 (4 ~ 20mA) 0 ~ 20,000 (0 ~ 20mA)
		Percentile value	0 ~ 10,000	
Max. resolution		1/16,000		
		0.250mV (1 ~ 5V) 0.3125mV (0 ~ 5V) 0.625mV (0 ~ 10V) 1.250mV (±10V)	1.0μA (4 ~ 20mA) 1.25μA (0 ~ 20mA)	
Accuracy		±0.2% or less (When ambient temperature 25℃) ±0.3% or less (When ambient temperature 0 ~ 55℃)		
Max. conversion speed		1ms/ channel		
Absolute max. input		DC ±15V	DC ±30mA	
Addition function	Filter	Digital filter(4 ~ 64,000ms)		
	Average	Time average (4~16,000ms)		
		Count average (2~64,000times)		
	Detection alarm	Disconnection(DC 1~5V, DC 4~20mA)		
	Hold last value	When input signal exceeds the effective range, holds the last effective value.		
Alarm function	When input signal exceeds the effective range, relevant flag turns on.			
Insulation method		Photo-coupler insulation between input terminal and PLC power (No insulation between channels)		
Connection terminal		15 point terminal block		
I/O points occupied		Fixed type assignment: 64		
Max. attachable number		7 [When using XBM-Dxxx□ (□: "S", "H", "H2", "HP") type] 7 (when using XB(E)C-DxxxSU type) 10 (when using XB(E)C-DxxxH type or XB(E)C-DxxxU type) Not Available (when using XB(E)C-DxxxE type)		
Consumption current	Internal (DC 5V)	105mA		
	External (DC 24V)	100mA		
Weight		72g		
Module input power		DC 20.4~28.8V		

Remark 1) To use the analog input module (14 Bit), It needs the basic unit more than below table.

Segment	Version
XBM-DxxxS Type	V3.30 or above
XBC-DxxxH Type	V2.20 or above
XBC-DxxxSU Type	V1.30 or above
XBC-DxxxS Type	V1.20 or above
XEC-DxxxH Type	V1.50 or above
XEC-DxxxSU Type	V1.10 or above
XG5000	V3.64 or above

### 13.3 Name of each Part and Functions

Respective designations of the parts are as described below.

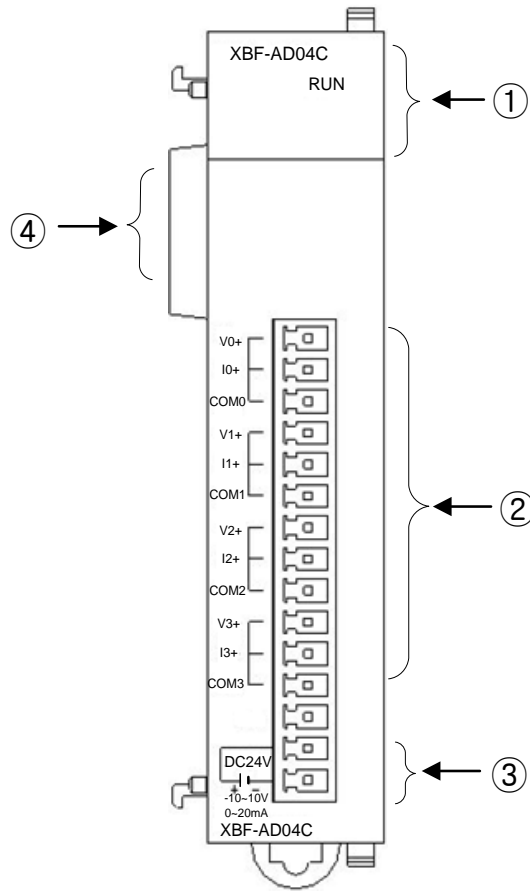

No.	Name	Description
①	RUN LED	▶ Displays the operation status of module On: Operation normal Blinks: Error occurs (Flickering 1s intervals) Off: Power off or module error
②	Terminal	▶ Wiring terminal block to connect with external device
③	External power supply	▶ Terminal for supplying the external DC24V
④	Ext. Connector	▶ Connector for extension modules.

### 13.4 Characteristic of I/O Conversion

Voltage/Current input ranges are able to set from each channel by using user program or I/O parameter. Data output type of digital is defined as below.

- (1) Unsigned Value
- (2) Signed Value
- (3) Precise Value
- (4) Percentile Value

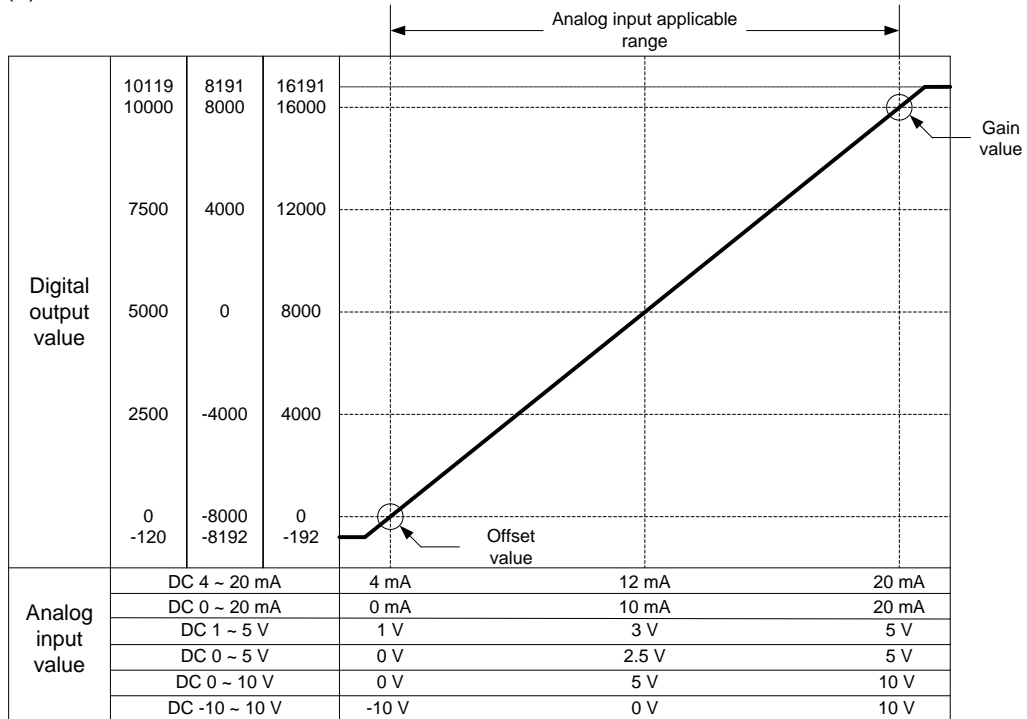

(1) DC 4 ~ 20mA Input range

Digital output range	Analog input current (mA)						
	3.808	4	8	12	16	20	20.191
Unsigned value (-192 ~ 16191)	-192	0	4,000	8,000	12,000	16,000	16,191
Signed value (-8192 ~ 8191)	-8,192	-8,000	-4,000	0	4,000	8,000	8,191
Precise value (3808 ~ 20191)	3,808	4,000	8,000	12,000	16,000	20,000	20,191
Percentile value (-120 ~ 10119)	-120	0	2,500	5,000	7,500	10,000	10,119

(2) DC 0 ~ 20mA Input range

Digital output range	Analog input current (mA)						
	-0.24	0	5	10	15	20	20.239
Unsigned value (-192 ~ 16191)	-192	0	4,000	8,000	12,000	16,000	16,191
Signed value (-8192 ~ 8191)	-8,192	-8,000	-4,000	0	4,000	8,000	8,191
Precise value (-240 ~ 20239)	-240	0	5,000	10,000	15,000	20,000	20,239
Percentile value (-120 ~ 10119)	-120	0	2,500	5,000	7,500	10,000	10,119



(3) DC 1 ~ 5V Input range

Digital output range	Analog input voltage (V)						
	0.952	1	2	3	4	5	5.047
Unsigned Value (-192 ~ 16,191)	-192	0	4,000	8,000	12,000	16,000	16,191
Signed Value (-8,192 ~ 8,191)	-8,192	-8,000	-4,000	0	4,000	8,000	8,191
Precise Value (952 ~ 5,047)	952	1,000	2,000	3,000	4,000	5,000	5,047
Percentile Value (-120 ~ 10,119)	-120	0	2,500	5,000	7,500	10,000	10,119

(4) DC 0 ~ 5V Input range

Digital output range	Analog input voltage (V)						
	-0.06	0	1.25	2.5	3.75	5	5.059
Unsigned Value (-192 ~ 16,191)	-192	0	4,000	8,000	12,000	16,000	16,191
Signed Value (-8,192 ~ 8,191)	-8,192	-8,000	-4,000	0	4,000	8,000	8,191
Precise Value (-60 ~ 5,059)	-60	0	1,250	2,500	3,750	5,000	5,059
Percentile Value (-120 ~ 10,119)	-120	0	2,500	5,000	7,500	10,000	10,119

(5) DC 0 ~ 10V Input range

Digital output range	Analog input voltage (V)						
	-0.12	0	2.5	5	7.5	10	10.119
Unsigned Value (-192 ~ 16,191)	-192	0	4,000	8,000	12,000	16,000	16,191
Signed Value (-8,192 ~ 8,191)	-8,192	-8,000	-4,000	0	4,000	8,000	8,191
Precise Value (-120 ~ 10,119)	-120	0	2,500	5,000	7,500	10,000	10,119
Percentile Value (-120 ~ 10,119)	-120	0	2,500	5,000	7,500	10,000	10,119

(6) DC -10 ~ 10V Input range

Digital output range	Analog input voltage (V)						
	-10.24	-10	-5	0	5	10	10.239
Unsigned Value (-192 ~ 16,191)	-192	0	4,000	8,000	12,000	16,000	16,191
Signed Value (-8,192 ~ 8,191)	-8,192	-8,000	-4,000	0	4,000	8,000	8,191
Precise Value (-10,240 ~ 10,239)	-10,240	-10,000	-5,000	0	5,000	10,000	10,239
Percentile Value (-120 ~ 10,119)	-120	0	2,500	5,000	7,500	10,000	10,119

## 13.5 Accuracy

Accuracy of digital output value does not change even if input range is changed. Figure below shows the range of the accuracy with analog input range of 0 ~ 10 V and digital output type of unsigned value selected.

Accuracy of XBF-AD04C is  $\pm 0.2\%$  (ambient temperature of 25 degrees)

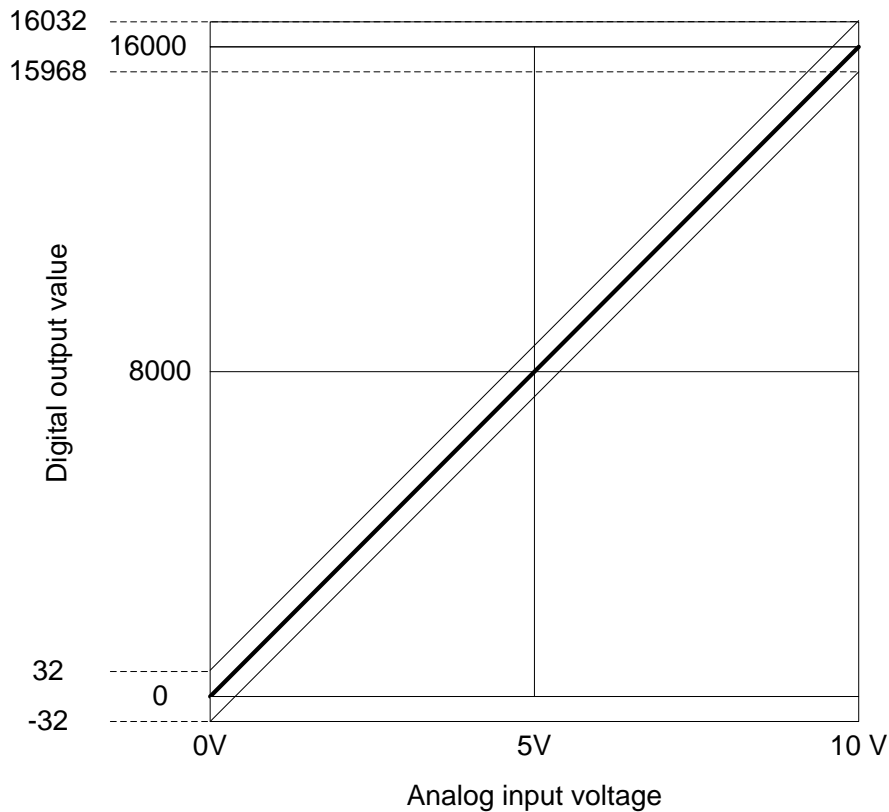

(1) Accuracy when using 5V input

$$16,000 \times 0.2\% = 32$$

Therefore the range of the accuracy will become  $(8,000-32) \sim (8,000+32) = 7,968 \sim 8,032$  when using 5V input.

(2) Accuracy when using 10V input

$$16,000 \times 0.2\% = 32$$

Therefore the range of the accuracy will become  $(16,000-32) \sim (16,000+32) = 15,968 \sim 16,032$  when using 10V input.

## 13.6 Functions of Analog Input Module

Functions of XBF-AD04C conversion module are as described below.

Function	Description
Channel Run/Stop setting	<ul style="list-style-type: none"> <li>● Specify Run/Stop of the channel to execute A/D conversion.</li> <li>● If the unused channel is set to Stop, whole Run time can be reduced.</li> </ul>
Input voltage/current range setting	<ul style="list-style-type: none"> <li>● Specify analog input range to be used.</li> <li>● Select range in parameter setting after select Voltage/Current switch.</li> <li>● Analog input module provides two kinds of current input ranges (4~20mA, 0~20mA) and four kinds of voltage input ranges (1~5V, 0~5V, 0~10V, 10~10V)</li> </ul>
Output data format setting	<ul style="list-style-type: none"> <li>● Specify digital output type.</li> <li>● 4 output data formats are provided in this module. (Unsigned value, Signed value, Precise value, Percentile value)</li> </ul>
A/D conversion methods	<ul style="list-style-type: none"> <li>● Sampling processing                             <ul style="list-style-type: none"> <li>- Sampling process will be performed if A/D conversion type is not specified.</li> </ul> </li> <li>● Filter processing                             <ul style="list-style-type: none"> <li>- Used to delay the sudden change of input value.</li> </ul> </li> <li>● Average processing                             <ul style="list-style-type: none"> <li>- Outputs average A/D conversion value based on frequency or time.</li> </ul> </li> <li>● Detection alarm                             <ul style="list-style-type: none"> <li>- After detecting whether disconnection of the input circuit, the alarm is displayed by a single flag. (Input signal range : 4 ~ 20mA, 1 ~ 5 V)</li> </ul> </li> <li>● Maintenance function of valid conversion value.                             <ul style="list-style-type: none"> <li>- When valid conversion value is exceeded, whether conversion value retains will be able to set.</li> </ul> </li> <li>● Alarm function                             <ul style="list-style-type: none"> <li>- When exceeding valid input range, alarm and maximum /minimum flag will be generated.</li> </ul> </li> </ul>

### 13.6.1 Sampling processing

It collects analog input sign through general A/D conversion processing at a specific interval to convert to digital. The time required for A/D conversion of analog input sign till saved on the memory depends on the number of channels used.

$$\text{(Processing time)} = \text{(Number of channels used)} \times \text{(Conversion speed)}$$

(Ex.) If the number of channels used is 3, its process time will be

$$3 \times 1 \text{ ms} = 3 \text{ ms}$$

Sampling is to calculate the sampling value of continuous analog sign at a specific interval.

### 13.6.2 Filter processing

Pre-filter input value and specified channel are calculated as below.

$$\text{Filtered Value} = \frac{(\text{Pre - Filtered Input Value} \times \text{Filter Constant}) + (\text{Current Input Value} \times 1\text{ms} \times \text{Number of used channels})}{\text{Filter Constant} + (1\text{ms} \times \text{Number of used channels})}$$

Setting range of Filter constant = 4 ~ 64,000 [ms]

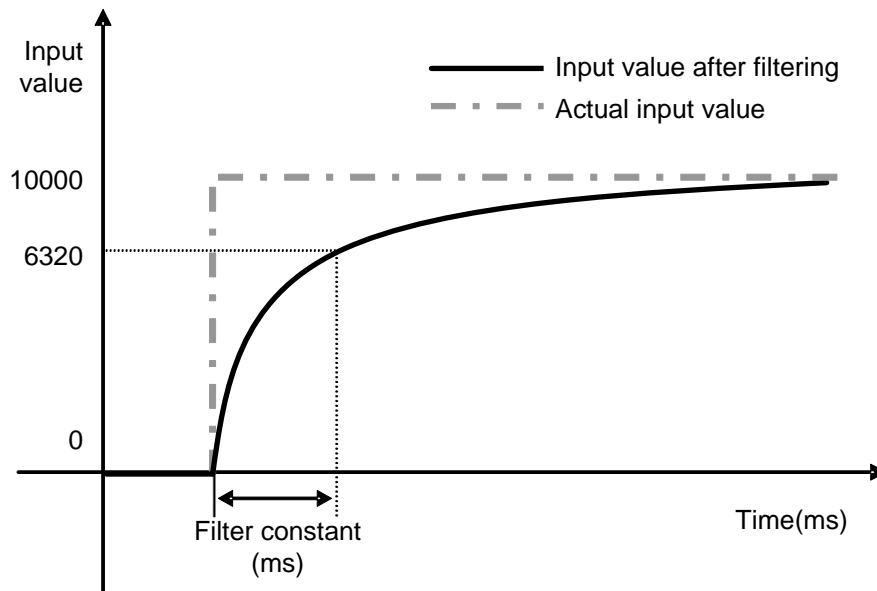

As the above graph, if the input value rapidly decreases from 0 to 10,000, the input value will be filtered. Specified time with filter constant is that the input value is the time to change by 63.2% of actual time constant.

### 13.6.3 Average processing

1) Time average

Input value of specified channel accumulates during setting time and then the average value of the sum is shown with digital data.

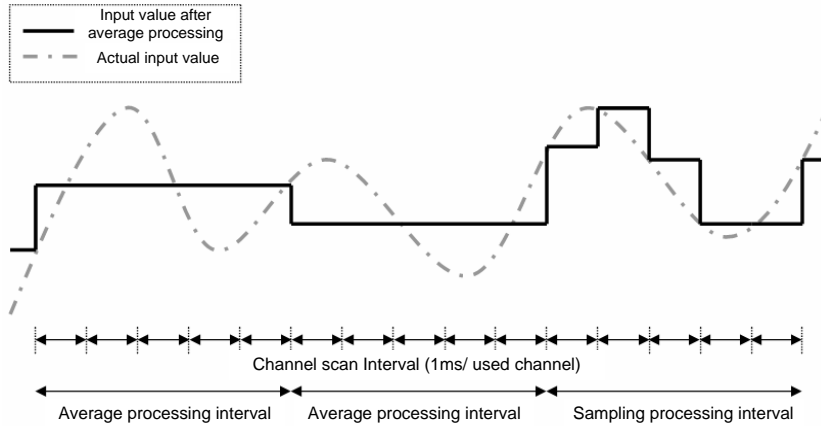

Setting range = 4 ~ 16,000 [ms]

In case of the time average, the average processing count is calculated by depending on the number of used channels.

$$\text{Average processing count} = \frac{\text{Average time}}{\text{Number of used channels} \times 1\text{ms}}$$

2) Number of averages

Input value of specified channel accumulates during setting numbers and then the average value of the sum is shown with digital data.

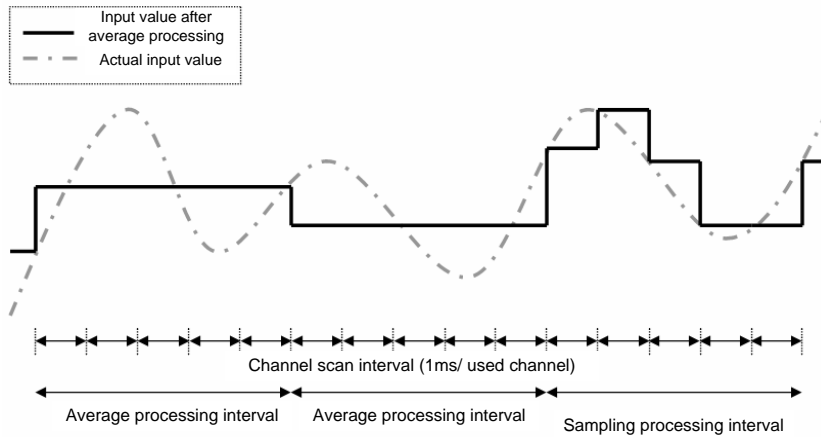

Setting range = 2 ~ 64,000 [times]

In case of number of averages, the average processing interval is calculated by depending on used channels.

**Average processing interval [ms]**

**= Number of averages × Number of used channels × 1ms**

### Notes

- (1) In case of the time/number of average, every conversion time input value is not outputted. And precondition is retained until the average time/number is arrived.
- (2) Two kinds of average functions and introduced filtering functions that are above are able to deal with at the same time.

When those are chosen at the same time, the top priority is filter function in the processing sequence. And then the chosen average function is adapted. Finally, digital data is outputted. At that time digital data value is outputted as the final processing value.

### 13.6.4 Detecting disconnection wire

In case that Input voltage(DC 1~5V) or Input current (DC 4~20 mA) is chosen with analog input range, the analog input module has diagnostic function by checking disconnection and showing. If the module shows disconnection, that means the parts of connections in the wiring connection are faulty. If so, check and take action.

(1) Detection conditions

When input signal range of 4~20mA and 1~5V is used, disconnection of input circuit can be detected. The detection conditions of each input signal range are as below.

Input signal range	Voltage/Current recognized as a disconnection
4 ~ 20 mA	0.8 mA or less
1 ~ 5 V	0.2 V or less

(2) When between used wiring and module is disconnected, the LED will be turned on/off 1s intervals and make an error code.

(3) Each channel can detect disconnection. However, Disconnection is only displayed for specified operation channel. The LED can commonly use the channel from 0 to 3. If one or more channel is disconnected, LED will be turned on/off.

Input connections	Channel operation	LED condition	Disconnection flag
Normal	Operation	On	Off
	Stop	On	Off
Input wiring is disconnected or Input is not connected.	Operation	Flickering 1s intervals	On
	Stop	On	Off

(4) In case of disconnection, disconnection flag of relevant channel will turn on and In case of connection, disconnection flag of relevant channel will turn off.

Disconnection flag		Description	Condition
XBM/XBC	XEC		
U0y.10.0	%UX0.y.160	Channel 0 disconnection	Off: Normal On: Disconnection
U0y.10.1	%UX0.y.161	Channel 1 disconnection	
U0y.10.2	%UX0.y.162	Channel 2 disconnection	
U0y.10.3	%UX0.y.163	Channel 3 disconnection	

※ The 'y' is a slot number equipped with a module.

(5) In case of disconnection, the input value displays the lowest value among each input range.

### 13.6.5 Function retaining valid conversion value

When the valid signal is out of the range, the last converted valid input value is retained.  
The function retaining valid conversion value is able to designate for each channel by user program and I/O parameter setting.

#### 1) Used input range

In the channels that allow the function retaining valid conversion value, the actual ranges provided within each digital conversion value are shown.

For example, in case of operating output data type of unsigned value, original digital output value is shown from -192 to 16,191.

However, if this function is allowed, it will be shown from 0 to 16,000.

#### (1) Digital output value depending on input range ( unsigned value, signed value, percentile value)

Classification	Unsigned value	Signed value	Precise value	Percentile value
Unapplied case	-192~16,191	-8,192~8,191	(2) Reference	-120~10,119
Applied case	0~16,000	-8,000~8,000		0~10,000

#### (2) Digital output value depending on input range (Precise value)

Analog input range	Classification	Precise value
4 ~ 20mA	Unapplied case	3,808~20,191
	Applied case	4,000~20,000
0 ~ 20mA	Unapplied case	-240~20,239
	Applied case	0~20,000
1 ~ 5V	Unapplied case	952~5,047
	Applied case	1,000~5,000
0 ~ 5V	Unapplied case	-60~5,059
	Applied case	0~5,000
0 ~ 10V	Unapplied case	-120~10,119
	Applied case	0~10,000
-10 ~ 10V	Unapplied case	-10,240~10,239
	Applied case	-10,000~10,000

#### 2) Operation

When operating with 4 ~ 20mA while being allowed this function, output value for input value change of the moment is as follows. (Output data type : In case of 0~16,000)

Input current(mA)	12mA	3mA	4mA	12mA	21mA	20mA
Digital output value	8,000	8,000	0	12,000	12,000	16,000
Remarks for reference	-	Retaining previous value	-	-	Retaining previous value	-



13.6.6 Alarm function

When the input signal is exceeded from valid value, the alarm will be shown through alarm flag of relevant channel.

1) Input detection function

Detection condition for each input signal range is as below.

Analog input range	Difference	Permission range	Low limit	High limit
4 ~ 20mA	16mA	1.2%	3.808mA	20.192mA
0 ~ 20mA	20mA		-0.24mA	20.24mA
1 ~ 5V	4V		0.952V	5.048V
0 ~ 5V	5V		-0.06V	5.06V
0 ~ 10V	10V		-0.12V	10.12V
-10 ~ 10V	20V		-10.24V	10.24V

2) Alarm sign of each channel

Alarm detection signal about each input channel is shown on U0y.11 and U0y.12. If the input signal come back, the alarm detection sign will automatically come back. (The 'y' is the slot number of equipped modules.)

(1) High limit alarm (U0X.11)

Device assignment		Description	Status description
XBM/XBC	XEC		
U0y.11.0	%UX0.y.176	Channel0 high limit alarm	Off: Normal On: Maximum alarm occurrence
U0y.11.1	%UX0.y.177	Channel1 high limit alarm	
U0y.11.2	%UX0.y.178	Channel2 high limit alarm	
U0y.11.3	%UX0.y.179	Channel3 high limit alarm	

(2) Low limit alarm (U0X.12)

Device assignment		Description	Status description
XBM/XBC	XEC		
U0y.12.0	%UX0.y.192	Channel0 low limit alarm	Off: Normal On: Maximum alarm occurrence
U0y.12.1	%UX0.y.193	Channel1 low limit alarm	
U0y.12.2	%UX0.y.194	Channel2 low limit alarm	
U0y.12.3	%UX0.y.195	Channel3 low limit alarm	

## 13.7 Installation and Wiring

### 13.7.1 Installation and separation of module

Notices in handling

Use the PLC within general specification ranges from instructions.

When the PLC is used out of the specified ranges, it will cause burning, getting electric shock, abnormal operation.



### Caution

- ▶ Fix the module after being equipped with binding bump of module.  
If the module is incorrectly attached, the module will be broken and malfunction.
- ▶ Please be careful for external impact, like falling the case of module, terminal connector.
- ▶ Do not separate the PCB board of module from the case.

#### (1) Installation of module

- Remove the extension cover above the module to connect.
- Push modules to connect each other after situating four positions binding correctly.
- After connection, fix the binding hook that is in the upward part and downward part completely.

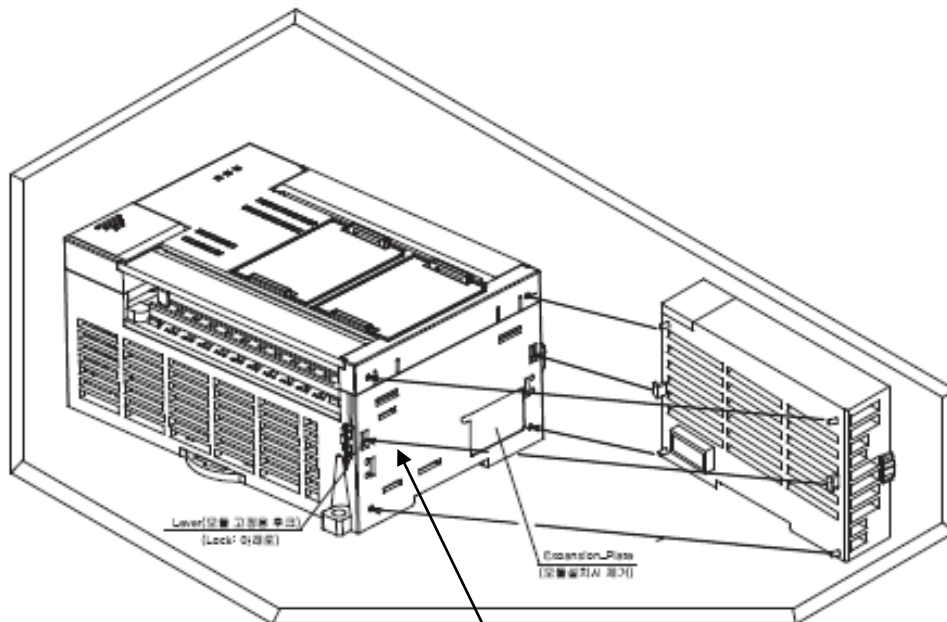

Hook for module fixing

(2) Separation of module

- Divide connections by lifting hook for module fixing in the upward part and downward part.
- Separate modules by holding modules with both hands. (Do not hold strongly in the module.)

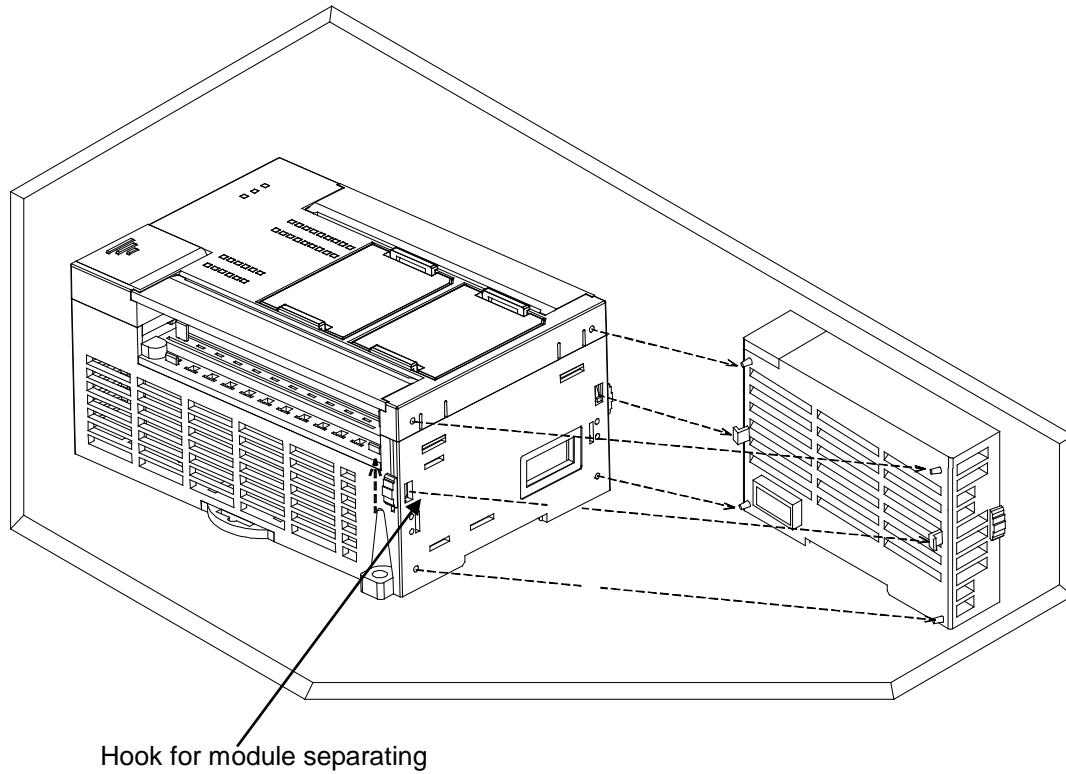

 **Caution**

- ▶ When you try to separate the modules strongly, the hook and bump for fixing will be broken.

### 13.7.2 Notices in wiring

- (1) Do not put the power line near the external I/O signal line of analog input module. You have to secure enough distance to avoid the interruption from the induced noise and the surge.
- (2) The wire has to select by considering permitted current and the ambient temperature.  
The maximum wire size is good in case of AWG22 (0.3mm<sup>2</sup>) or more.
- (3) When the wire is so near with high temperature machines and materials and touched with oil for a long time, it can be short circuit and malfunction.
- (4) When doing terminal ports wiring, check the polarity.
- (5) In case that the high voltage line and the power line are wired at the same time, the induced interruption is caused. So it can be a reason for breakdown.

### 13.7.3 Example for the wiring

- (1) The input resistance of current input circuit is 250Ω (typ.).
- (2) The input resistance of voltage input circuit is 1 MΩ (min.).
- (3) Set the operation mode only if you want to use channels.
- (4) The analog input module doesn't provide the power for input device.  
Use the external power device.
- (5) Example for analog input wiring

When inputting the voltage, relevant channel V+ and COM terminal is used. When inputting the current, relevant channel V+ and COM terminal is used after connecting between V+ and I+ terminal.

#### a) Voltage wiring

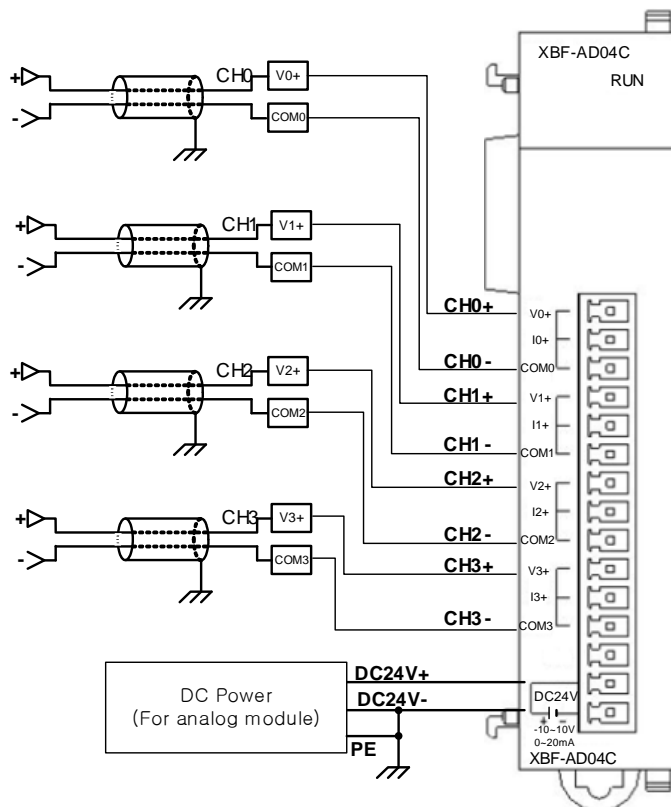

※ DC power for analog power supply have to connect DC24V- with PE.

b) Current wiring

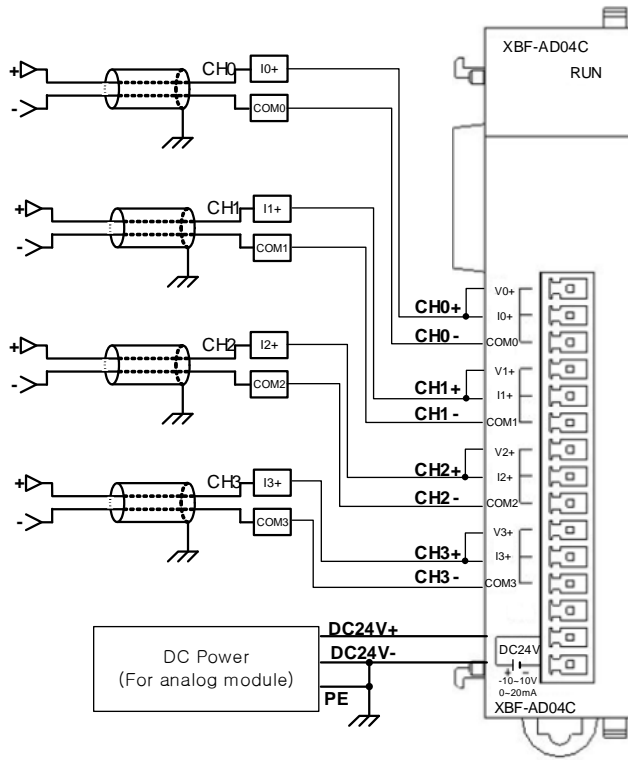

※ DC power for analog power supply have to connect DC24V- with PE.

- (6) The example of analog input 2-Wire sensor/transmitter wiring(The current wiring)  
Use the I+ and COM terminal after connecting V+ with I+ terminal.

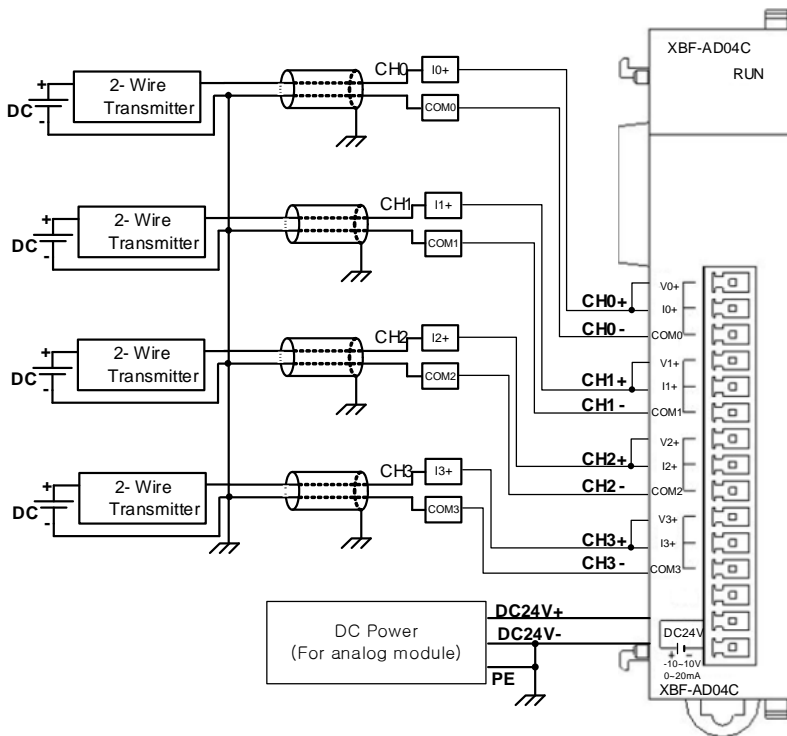

※ DC power for analog power supply have to connect DC24V- with PE.

(7) The example of analog input 4-Wire sensor/transmitter wiring(The current input)  
 Use the I+ and COM terminal after connecting V+ with I+ terminal.

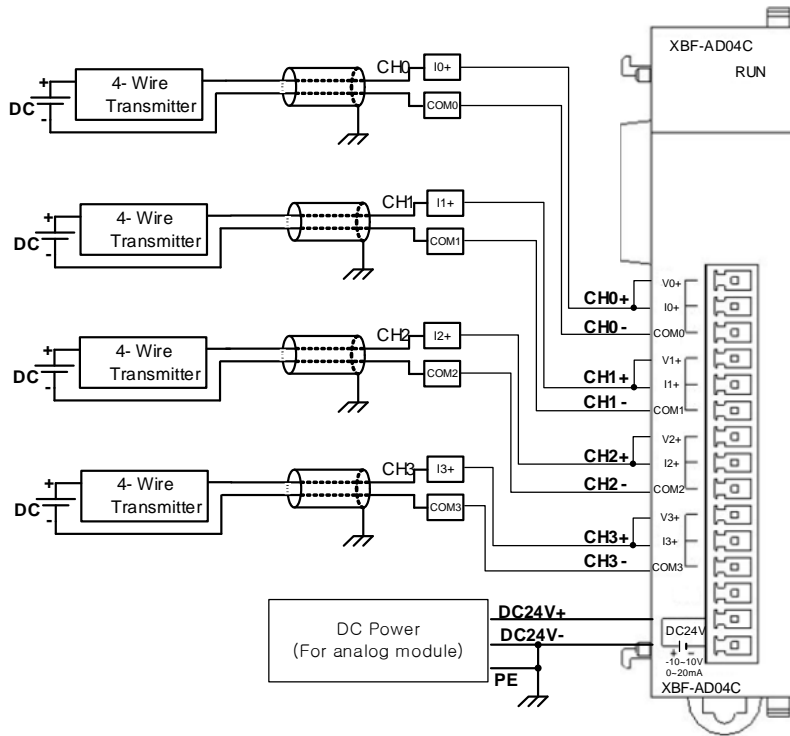

※ DC power for analog power supply have to connect DC24V- with PE.

(8) Relationship between voltage input accuracy and wiring length

In voltage input, the wiring (cable) length between transmitter or sensor and module has an effect on digital-converted values of the module as specified below;

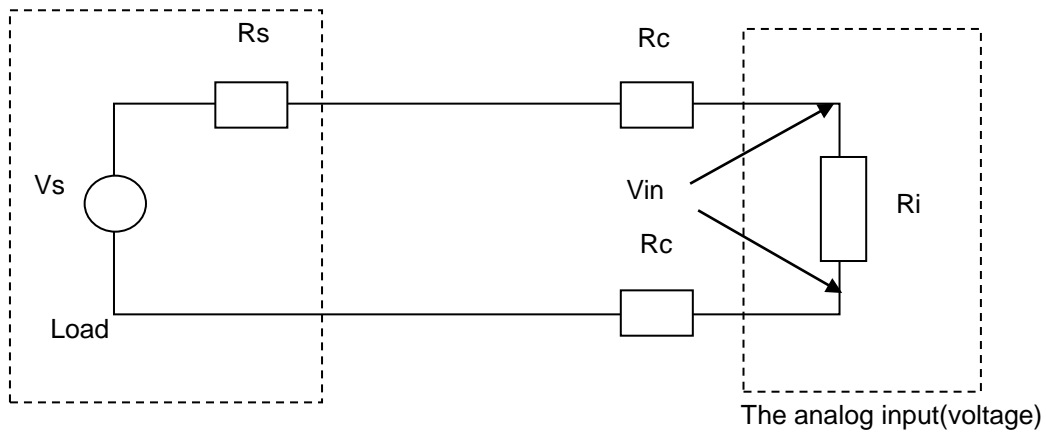

Where,

$R_c$ : Resistance value due to line resistance of cable

$R_s$ : Internal resistance value of transmitter or sensor

$R_i$ : Internal resistance value ( $1M\Omega$ ) of voltage input module

$V_{in}$ : Voltage allowed to analog input module

%  $V_i$ : Tolerance of converted value (%) due to source and cable length in voltage input

$$V_{in} = \frac{R_i \times V_s}{[R_s + (2 \times R_c) + R_i]}$$

$$\% V_i = \left(1 - \frac{V_{in}}{V_s}\right) \times 100\%$$

**Remark**

(1) While using a input voltage range among 1~5V, 0~5V, 0~10V, -10~10V  
 If the external wiring is disconnected, It will take a certain amount of time to display output data value of 0V. If you want to reduce that time, connect the resistance about  $0.1M\Omega \sim 1M\Omega$  between input channel V+ and COM.

## 13.8 Operation Parameter Setting

A/D conversion module's operation parameters can be specified through XG5000's [I/O parameters].

### (1) Settings

For the user's convenience of A/D conversion module, XG5000 provides GUI (Graphical User Interface) for parameters setting of A/D conversion module. Setting items available through [I/O parameters] on the XG5000 project window are as described below in the table.

Item	Details
[I/O parameter]	<p>(a) Parameter setting Specify the following setting items necessary for the module operation.</p> <ol style="list-style-type: none"> <li>1) Channel Enable/Disable setting</li> <li>2) Input voltage(current) range</li> <li>3) Output data format setting</li> <li>4) Filter constant setting</li> <li>5) Average processing method setting</li> <li>6) Average value setting</li> </ol> <p>(b) When the parameters set by user in XG5000 is downloaded, that data is saved in flash memory of XGB basic unit.</p>

### 2) [I/O Parameter] Using method

- (1) Run XG5000 to create a project.  
(Refer to XG5000 program manual for details on how to create the project)
- (2) Double-click [I/O parameters] on the project window.

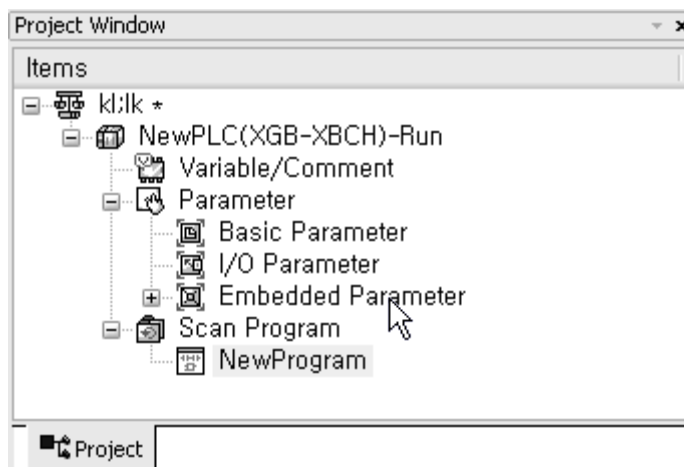



(3) [I/O Parameter setting] On the 'I/O parameters setting' screen, find and click the slot equipped with analog input module.

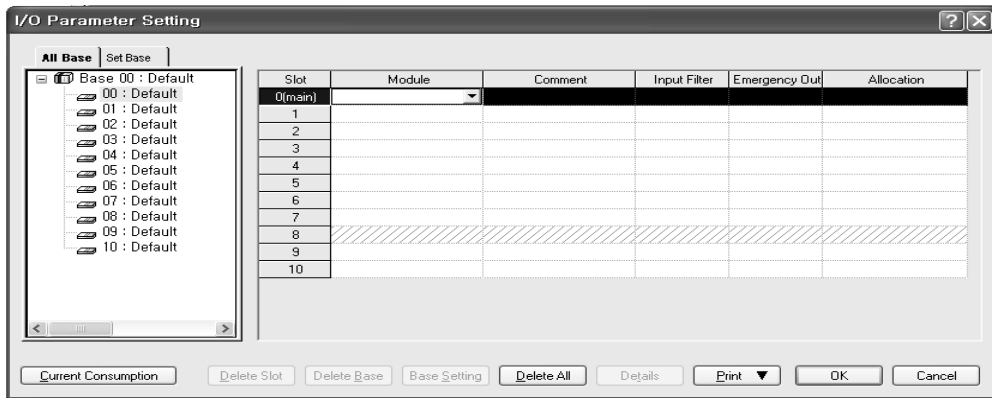

(4) Click the arrow button on the screen above to display the screen where an applicable module can be selected. Search for the applicable module to select.

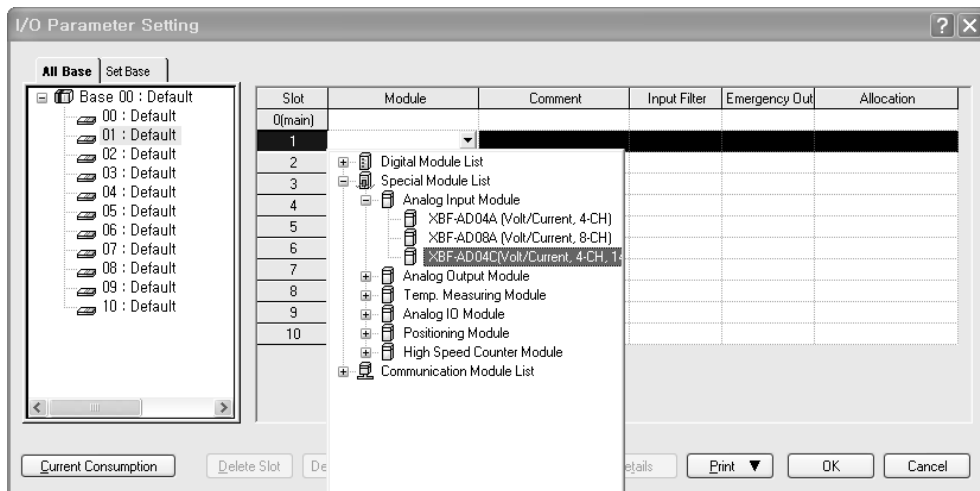

(5) After the module selected, click [Details].

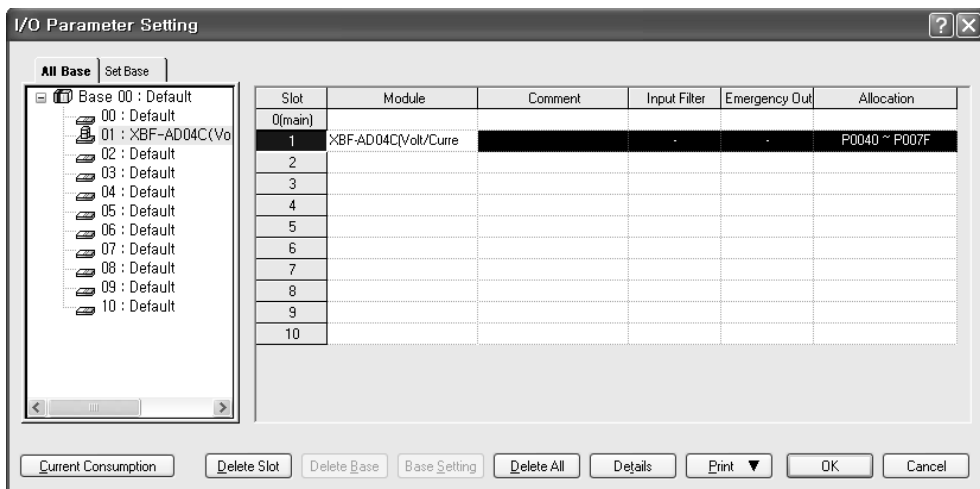

- (6) A screen will be displayed for you to specify parameters for respective channels as below. Click a desired item to display parameters to set for respective items.

XBF-AD04C(Volt/Current, 4-CH, 14bit) ? X

XBF-AD04C(Volt/Current, 4-CH, 14bit)

Parameter	CH0	CH1	CH2	CH3
<input type="checkbox"/> Channel status	Disable	Disable	Disable	Disable
<input type="checkbox"/> Input range	4~20mA	4~20mA	4~20mA	4~20mA
Output type	0~16000	0~16000	0~16000	0~16000
Filter constant	0	0	0	0
<input type="checkbox"/> Average processing	Sampling	Sampling	Sampling	Sampling
Average value	0	0	0	0
<input type="checkbox"/> Hold last value	Disable	Disable	Disable	Disable

## 13.9 Special Module Monitoring Functions

Functions of Special Module Monitoring are as described below.

**1) Start of [Special Module Monitoring]**

Go through [Online] → [Connect] and [Monitor] → [Special module Monitoring] to start. If the status is not online, [Special Module Monitoring] menu will not be activated.

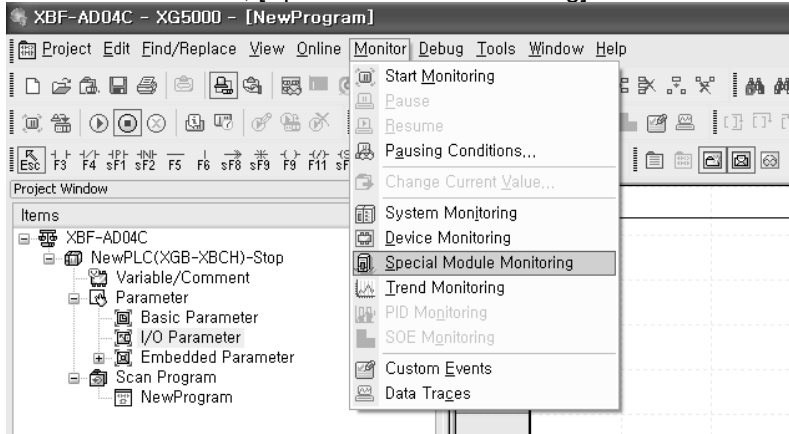

**Notes**

- 1) The screen may not normally be shown due to the lack of system resource. In this case, terminate all applications and try to start XG5000 again.
- 2) I/O parameter set in status of [Special Module Monitor] is temporarily set to implement the test. So, If status of [Special Module Monitor] is ended, I/O parameter which is set becomes extinct.
- 3) The test of [Special Module Monitor] is a examination function to check operation of the analog input module when the sequence program is not made up.

**2) How to use special module monitoring**

- (1) With XG5000 connected to PLC CPU (on-line status), click [Monitor] -> [Special Module Monitoring] to display 'Special Module Select' screen as below showing base/slot information in addition to special module type. The module installed on the present PLC system will be displayed on the list dialog box.

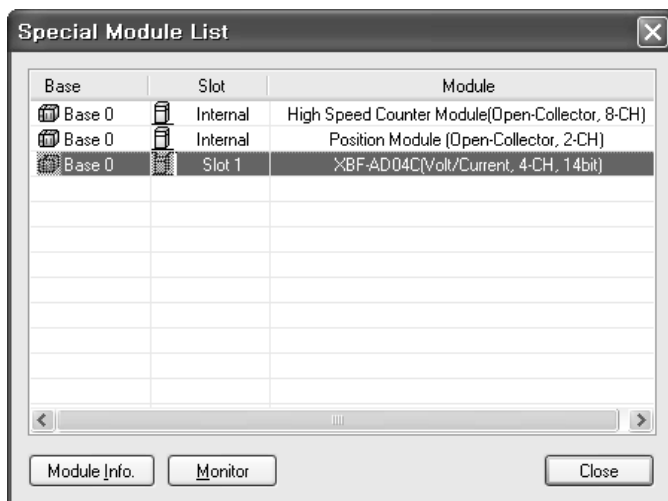

- (2) Select “Special Module” and click [Module information] to display the information as below.

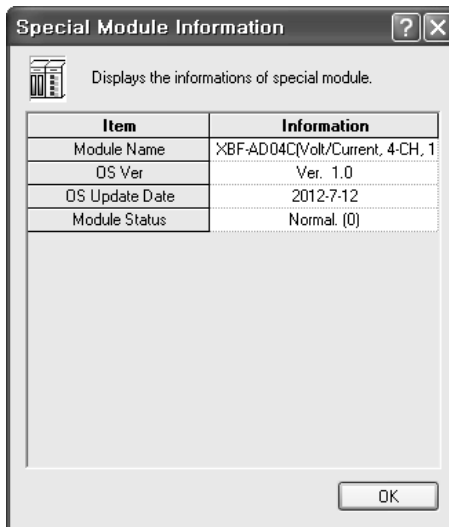

- (3) Click [Monitor] on the “Special Module” screen in [Special Module List] to display [Special Module Monitoring] screen as below.

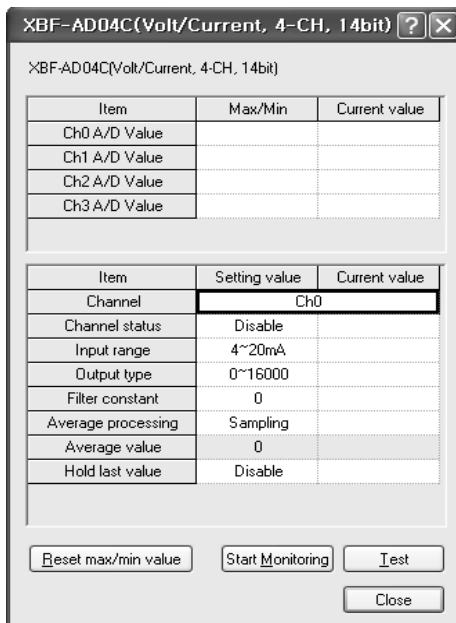

- (4) Start Monitoring: Click [Start Monitoring] to show digital input data of current operated channel. When the channel is operating you can see the painting through monitor.

The screenshot shows the 'XBF-AD04C(Volt/Current, 4-CH, 14bit)' monitoring window. It contains two tables and several buttons.

Item	Max/Min	Current value
Ch0 A/D Value	0 / 0	0
Ch1 A/D Value	0 / 0	0
Ch2 A/D Value	0 / 0	0
Ch3 A/D Value	0 / 0	0

Item	Setting value	Current value
Channel	Ch0	
Channel status	Disable	Disable
Input range	4~20mA	4~20mA
Output type	0~16000	0~16000
Filter constant	0	0
Average processing	Sampling	Sampling
Average value	0	0
Hold last value	Disable	Disable

Buttons at the bottom: Reset max/min value, Stop Monitoring, Test, Close.

Annotations: 'Monitoring' points to the first table, and 'CH0 details' points to the second table.

Execution screen of [Start Monitoring]

- (5) Test: [Test] is a function to change the parameter of the analog input module which is presently set. In case of clicking the setting value in the bottom of the screen, you can change the parameter. [Test] is able to set only if operation status of XGB's basic unit is stop.

The screenshot shows the 'XBF-AD04C(Volt/Current, 4-CH, 14bit)' monitoring window after the 'Test' button was clicked. The 'Channel status' in the second table has changed from 'Disable' to 'Enable'.

Item	Max/Min	Current value
Ch0 A/D Value	0 / 0	0
Ch1 A/D Value	0 / 0	0
Ch2 A/D Value	0 / 0	0
Ch3 A/D Value	0 / 0	0

Item	Setting value	Current value
Channel	Ch0	
Channel status	Enable	Enable
Input range	4~20mA	4~20mA
Output type	0~16000	0~16000
Filter constant	0	0
Average processing	Sampling	Sampling
Average value	0	0
Hold last value	Disable	Disable

Buttons at the bottom: Reset max/min value, Stop Monitoring, Test, Close.

Execution screen of [Test]

## (6) Max/Min Value Monitor

Max/Min value of input channel in operation can be monitored. However, visible Max/Min values are based on present value.

So Max/Min value is not saved when [Monitoring/Test Screen] is closed.

XBF-AD04C(Volt/Current, 4-CH, 14bit) [?] [X]

XBF-AD04C(Volt/Current, 4-CH, 14bit)

Item	Max/Min	Current value
Ch0 A/D Value	0 / 0	0
Ch1 A/D Value	0 / 0	0
Ch2 A/D Value	0 / 0	0
Ch3 A/D Value	0 / 0	0

Monitoring of Max/Min value

Item	Setting value	Current value
Channel	Ch0	
Channel status	Disable	Enable
Input range	-10~10V	4~20mA
Output type	0~16000	0~16000
Filter constant	0	0
Average processing	Sampling	Sampling
Average value	0	0
Hold last value	Disable	Disable

Reset of Max/Min value

[Reset max/min value] [Stop Monitoring] [Test] [Close]

[Max/Min Value Monitor] execution screen

## (7) Close

[Close]: [Close] is used to escape from the monitoring/test screen. When the monitoring/test screen is closed, the max. value, the min. value and the present value will not be saved any more.

## 13.10 Register U Devices

Register the variables for each module referring to the special module information that is set in the I/O parameter. The user can modify the variables and comments.

### 1) Procedure

(1) Select the special module type in the [I/O Parameter Setting] window.

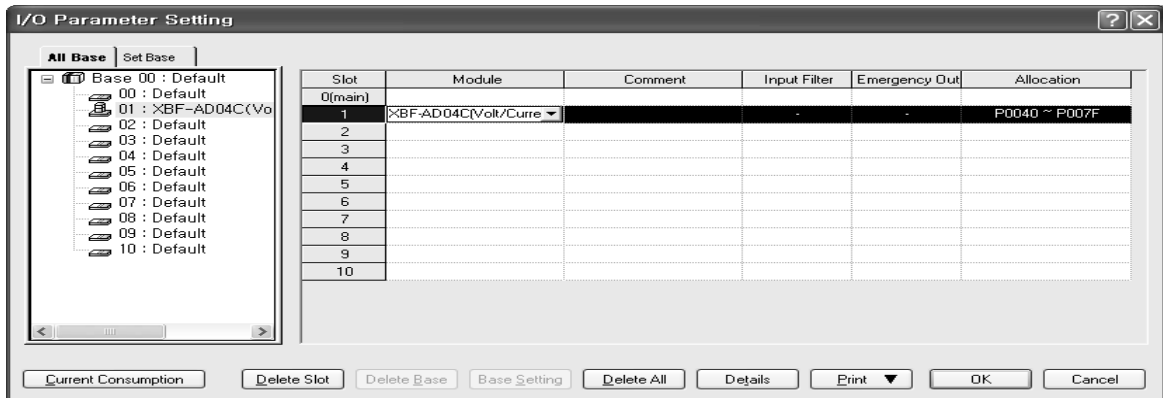

(2) Double click 'Variable/Comment' from the project window.

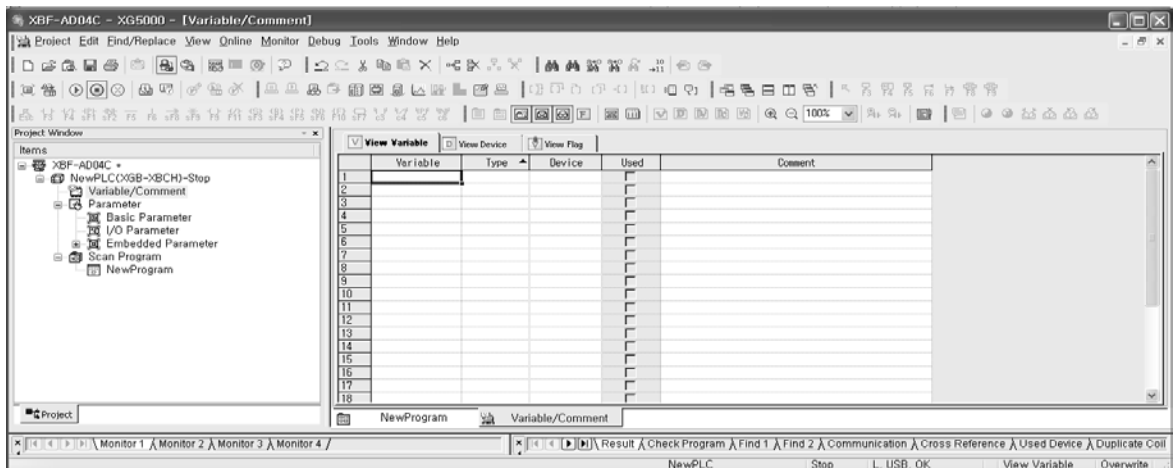

(3) Select [Edit] – [Register U Device].

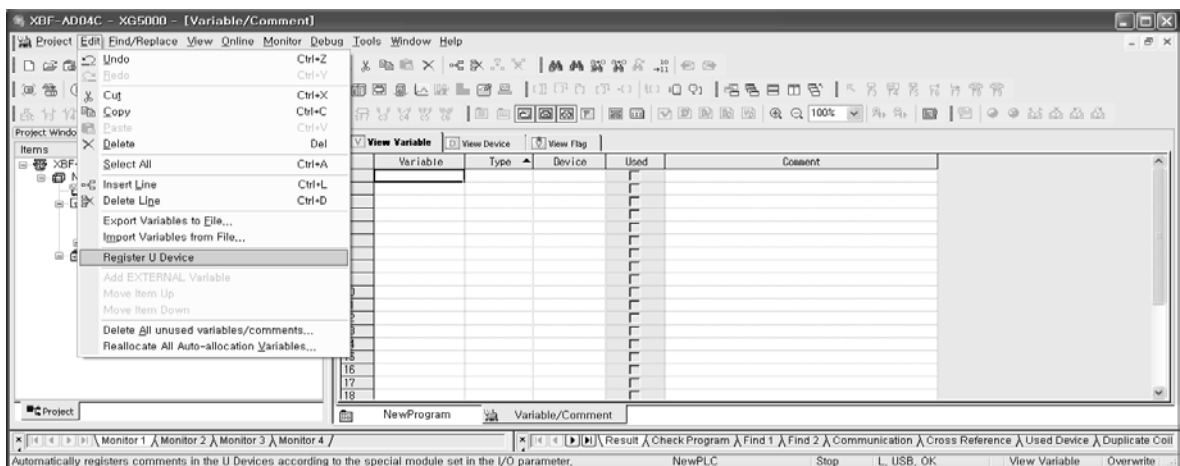

(4) Click 'Yes'

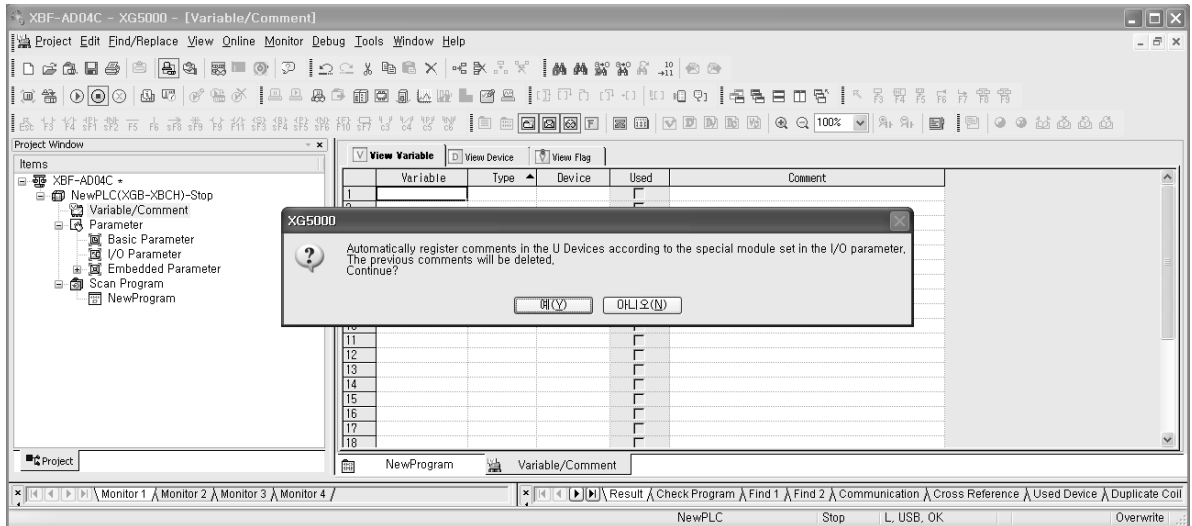

(5) As shown below, the variables are registered.

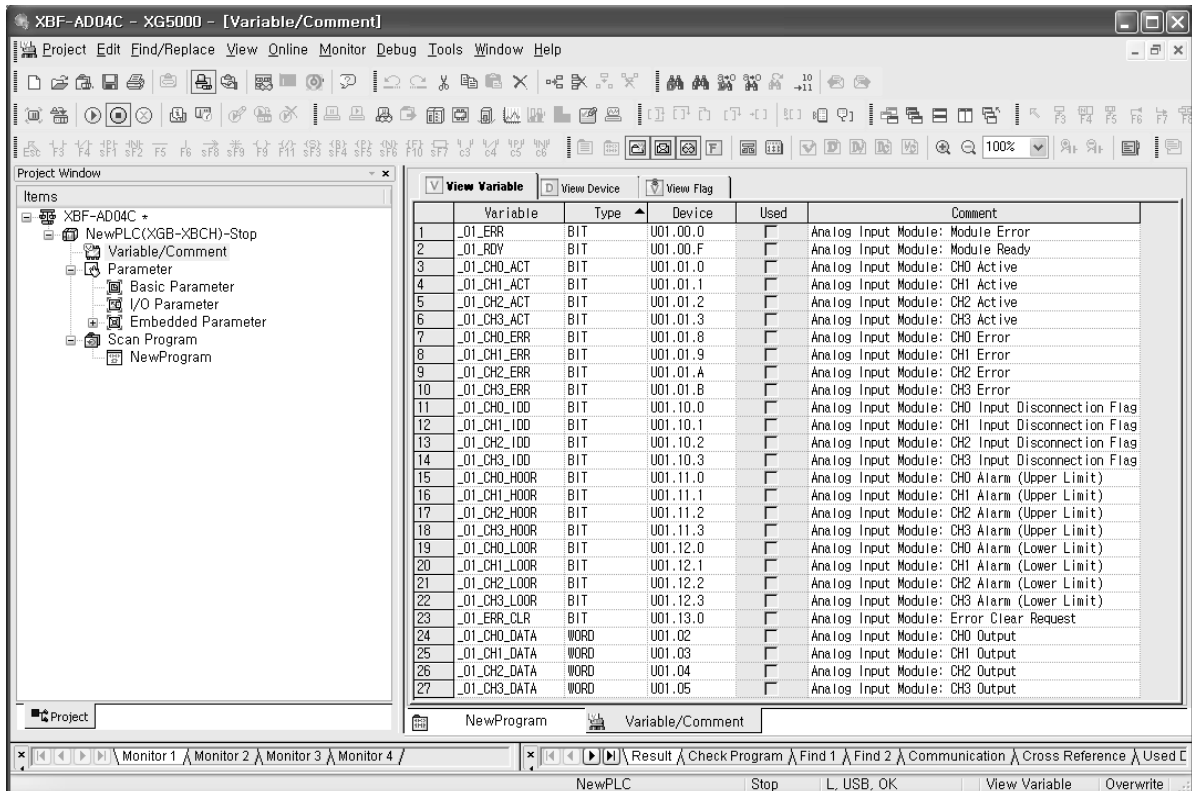



(6) For IEC type, as shown below, the variables are registered.

Variable Kind	Variable	Type	Address	Initial Value	Retain	Used	EIP	Comment
1	VAR_GLOBAL	_01_CH0_ACT	BOOL	\$XUD.1.16		<input type="checkbox"/>	<input type="checkbox"/>	Analog Input Module: CH0 Active
2	VAR_GLOBAL	_01_CH0_DATA	WORD	\$XUD.1.2		<input type="checkbox"/>	<input type="checkbox"/>	Analog Input Module: CH0 Output
3	VAR_GLOBAL	_01_CH0_ERR	BOOL	\$XUD.1.24		<input type="checkbox"/>	<input type="checkbox"/>	Analog Input Module: CH0 Error
4	VAR_GLOBAL	_01_CH0_HOOR	BOOL	\$XUD.1.176		<input type="checkbox"/>	<input type="checkbox"/>	Analog Input Module: CH0 Alarm (Upper Limit)
5	VAR_GLOBAL	_01_CH0_IDO	BOOL	\$XUD.1.160		<input type="checkbox"/>	<input type="checkbox"/>	Analog Input Module: CH0 Input Disconnection Flag
6	VAR_GLOBAL	_01_CH0_LOOR	BOOL	\$XUD.1.192		<input type="checkbox"/>	<input type="checkbox"/>	Analog Input Module: CH0 Alarm (Lower Limit)
7	VAR_GLOBAL	_01_CH1_ACT	BOOL	\$XUD.1.17		<input type="checkbox"/>	<input type="checkbox"/>	Analog Input Module: CH1 Active
8	VAR_GLOBAL	_01_CH1_DATA	WORD	\$XUD.1.3		<input type="checkbox"/>	<input type="checkbox"/>	Analog Input Module: CH1 Output
9	VAR_GLOBAL	_01_CH1_ERR	BOOL	\$XUD.1.25		<input type="checkbox"/>	<input type="checkbox"/>	Analog Input Module: CH1 Error
10	VAR_GLOBAL	_01_CH1_HOOR	BOOL	\$XUD.1.177		<input type="checkbox"/>	<input type="checkbox"/>	Analog Input Module: CH1 Alarm (Upper Limit)
11	VAR_GLOBAL	_01_CH1_IDO	BOOL	\$XUD.1.161		<input type="checkbox"/>	<input type="checkbox"/>	Analog Input Module: CH1 Input Disconnection Flag
12	VAR_GLOBAL	_01_CH1_LOOR	BOOL	\$XUD.1.193		<input type="checkbox"/>	<input type="checkbox"/>	Analog Input Module: CH1 Alarm (Lower Limit)
13	VAR_GLOBAL	_01_CH2_ACT	BOOL	\$XUD.1.18		<input type="checkbox"/>	<input type="checkbox"/>	Analog Input Module: CH2 Active
14	VAR_GLOBAL	_01_CH2_DATA	WORD	\$XUD.1.4		<input type="checkbox"/>	<input type="checkbox"/>	Analog Input Module: CH2 Output
15	VAR_GLOBAL	_01_CH2_ERR	BOOL	\$XUD.1.26		<input type="checkbox"/>	<input type="checkbox"/>	Analog Input Module: CH2 Error
16	VAR_GLOBAL	_01_CH2_HOOR	BOOL	\$XUD.1.178		<input type="checkbox"/>	<input type="checkbox"/>	Analog Input Module: CH2 Alarm (Upper Limit)
17	VAR_GLOBAL	_01_CH2_IDO	BOOL	\$XUD.1.162		<input type="checkbox"/>	<input type="checkbox"/>	Analog Input Module: CH2 Input Disconnection Flag
18	VAR_GLOBAL	_01_CH2_LOOR	BOOL	\$XUD.1.194		<input type="checkbox"/>	<input type="checkbox"/>	Analog Input Module: CH2 Alarm (Lower Limit)
19	VAR_GLOBAL	_01_CH3_ACT	BOOL	\$XUD.1.19		<input type="checkbox"/>	<input type="checkbox"/>	Analog Input Module: CH3 Active
20	VAR_GLOBAL	_01_CH3_DATA	WORD	\$XUD.1.5		<input type="checkbox"/>	<input type="checkbox"/>	Analog Input Module: CH3 Output
21	VAR_GLOBAL	_01_CH3_ERR	BOOL	\$XUD.1.27		<input type="checkbox"/>	<input type="checkbox"/>	Analog Input Module: CH3 Error
22	VAR_GLOBAL	_01_CH3_HOOR	BOOL	\$XUD.1.179		<input type="checkbox"/>	<input type="checkbox"/>	Analog Input Module: CH3 Alarm (Upper Limit)
23	VAR_GLOBAL	_01_CH3_IDO	BOOL	\$XUD.1.163		<input type="checkbox"/>	<input type="checkbox"/>	Analog Input Module: CH3 Input Disconnection Flag
24	VAR_GLOBAL	_01_CH3_LOOR	BOOL	\$XUD.1.195		<input type="checkbox"/>	<input type="checkbox"/>	Analog Input Module: CH3 Alarm (Lower Limit)
25	VAR_GLOBAL	_01_ERR	BOOL	\$XUD.1.0		<input type="checkbox"/>	<input type="checkbox"/>	Analog Input Module: Module Error
26	VAR_GLOBAL	_01_ERR_CLR	BOOL	\$XUD.1.208		<input type="checkbox"/>	<input type="checkbox"/>	Analog Input Module: Error Clear Request
27	VAR_GLOBAL	_01_RDY	BOOL	\$XUD.1.15		<input type="checkbox"/>	<input type="checkbox"/>	Analog Input Module: Module Ready
28								

2) Save variables

- (1) The contents of 'View Variable' can be saved as a text file.
- (2) Select [Edit] -> [Export to File].
- (3) The contents of 'View variable' are saved as a text file.

3) View variables

The example of XBC type is as follows.

(1) The example program of XG5000 is as shown below.

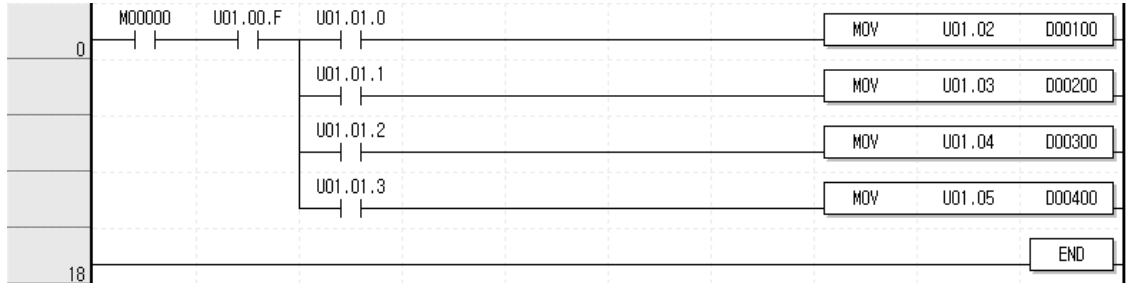

(2) Select [View] -> [Variables]. The devices are changed into variables.

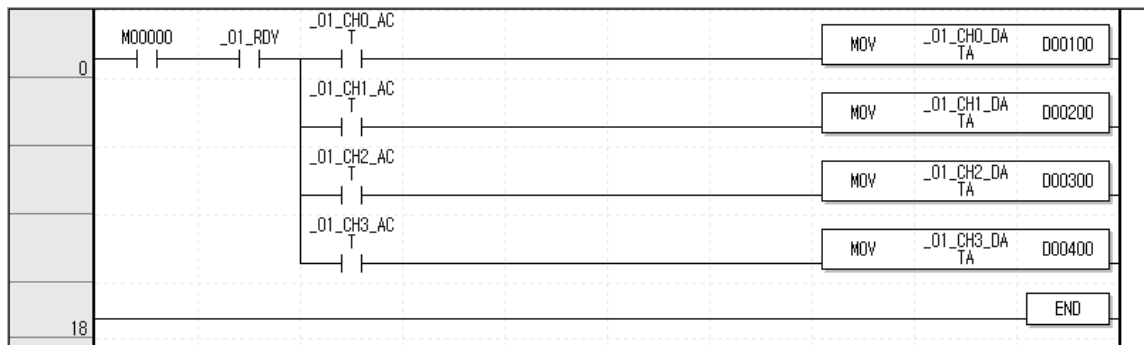

(3) Select [View] -> [Devices/Variables]. Devices and variables are both displayed.

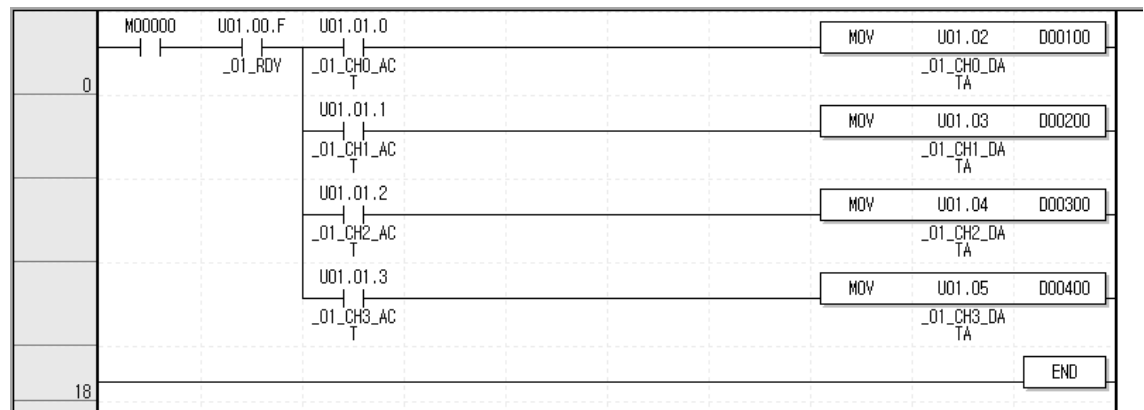

(4) Select [View] -> [Device/Comments]. Devices and comments are both displayed.

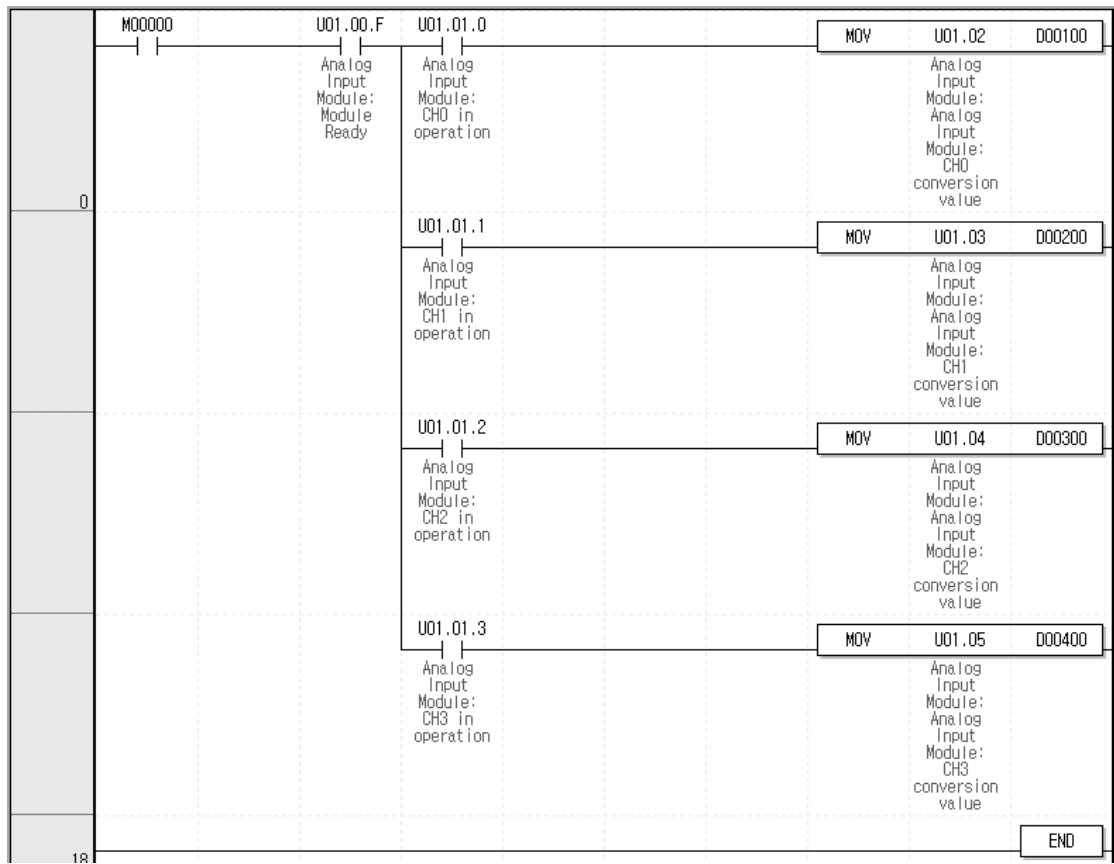

(5) Select [View] -> [Variables/Comments]. Variables and comments are both displayed.

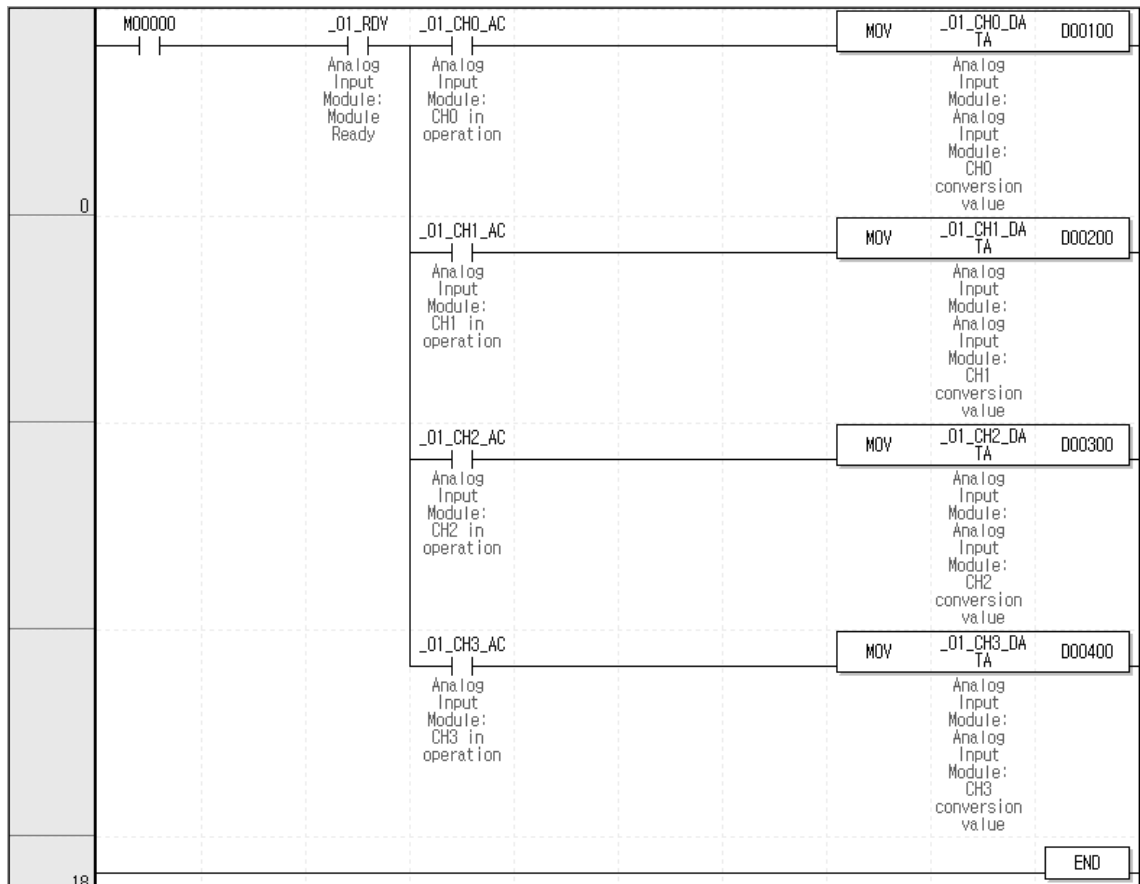

(6) In case of IEC, you can see variables with diverse option at 'View' menu like (1)~(5).  
 The following is example selecting 'View Variable/Comment' at IEC type.

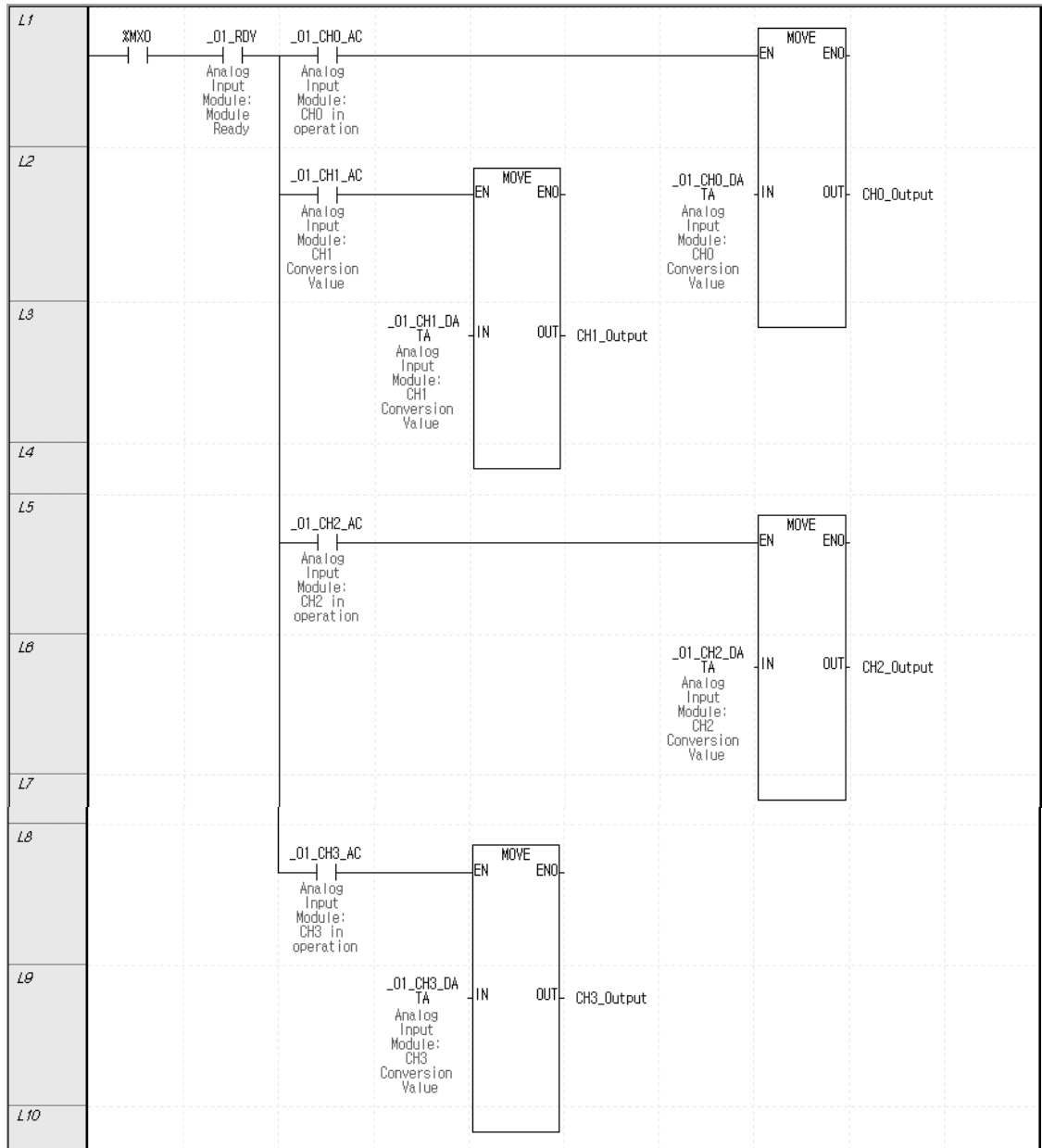

### 13.11 Configuration and Function of Internal Memory

A/D conversion module has the internal memory to transmit/receive data to/from PLC CPU.

#### 13.11.1 I/O area of A/D converted data

I/O area of A/D converted data is as displayed in table.

Variable name	Type	Device assigned		Details	R/W	Direction of signal
		XBM/XBC	XEC (IEC type)			
_0y_ERR	BIT	U0y.00.0	%UX0.y.0	Module Error	R	AD04C → CPU
_0y_RDY	BIT	U0y.00.F	%UX0.y.15	Module Ready		
_0y_CH0_ACT	BIT	U0y.01.0	%UX0.y.16	Channel 0 Run	W	AD04C → CPU
_0y_CH1_ACT	BIT	U0y.01.1	%UX0.y.17	Channel 1 Run		
_0y_CH2_ACT	BIT	U0y.01.2	%UX0.y.18	Channel 2 Run		
_0y_CH3_ACT	BIT	U0y.01.3	%UX0.y.19	Channel 3 Run		
_0y_CH0_ERR	BIT	U0y.01.8	%UX0.y.24	Channel 0 Error	R	AD04C → CPU
_0y_CH1_ERR	BIT	U0y.01.9	%UX0.y.25	Channel 1 Error		
_0y_CH2_ERR	BIT	U0y.01.A	%UX0.y.26	Channel 2 Error		
_0y_CH3_ERR	BIT	U0y.01.B	%UX0.y.27	Channel 3 Error		
_0y_CH0_DATA	WORD	U0y.02	%UW0.y.2	Channel 0 Conversion value	R	AD04C → CPU
_0y_CH1_DATA	WORD	U0y.03	%UW0.y.3	Channel 1 Conversion value		
_0y_CH2_DATA	WORD	U0y.04	%UW0.y.4	Channel 2 Conversion value		
_0y_CH3_DATA	WORD	U0y.05	%UW0.y.5	Channel 3 Conversion value		
_0y_CH0_IDD	BIT	U0y.10.0	%UX0.y.160	Channel 0 Disconnection detection	R	AD04C → CPU
_0y_CH1_IDD	BIT	U0y.10.1	%UX0.y.161	Channel 1 Disconnection detection		
_0y_CH2_IDD	BIT	U0y.10.2	%UX0.y.162	Channel 2 Disconnection detection		
_0y_CH3_IDD	BIT	U0y.10.3	%UX0.y.163	Channel 3 Disconnection detection		
_0y_CH0_HOOR	BIT	U0y.11.0	%UX0.y.176	Channel 0 High limit alarm	R	AD04C → CPU
_0y_CH1_HOOR	BIT	U0y.11.1	%UX0.y.177	Channel 1 High limit alarm		
_0y_CH2_HOOR	BIT	U0y.11.2	%UX0.y.178	Channel 2 High limit alarm		
_0y_CH3_HOOR	BIT	U0y.11.3	%UX0.y.179	Channel 3 High limit alarm		
_0y_CH0_LOOR	BIT	U0y.12.0	%UX0.y.192	Channel 0 Low limit alarm	R	AD04C → CPU
_0y_CH1_LOOR	BIT	U0y.12.1	%UX0.y.193	Channel 1 Low limit alarm		
_0y_CH2_LOOR	BIT	U0y.12.2	%UX0.y.194	Channel 2 Low limit alarm		
_0y_CH3_LOOR	BIT	U0y.12.3	%UX0.y.195	Channel 3 Low limit alarm		
_0y_ERR_CLR	BIT	U0y.13.0	%UX0.y.208	Error clear request	W	AD04C ← CPU

- In the device assigned, 'y' means slot number equipped with module.
- In order to read 'CH3 conversion value' of A/D conversion module installed on Slot No.4, it shall be displayed as U04.05. (In case of IEC type %UW0.4.5)

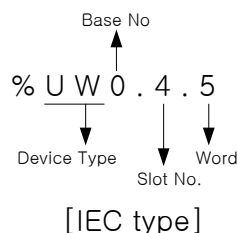
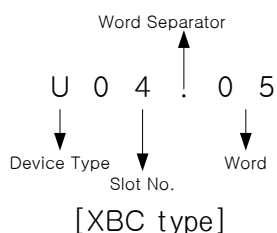

- 1) Module Ready/Error flag ( ' ( ) ' means the case of IEC type, y: slot number)
  - (1) U0y.00.F(%UX0.y.15) : It will be ON when PLC CPU is powered or reset with A/D conversion ready to process A/D conversion.
  - (2) U0y.00.0(%UX0.y.0) : It is a flag to display the error status of A/D conversion module.

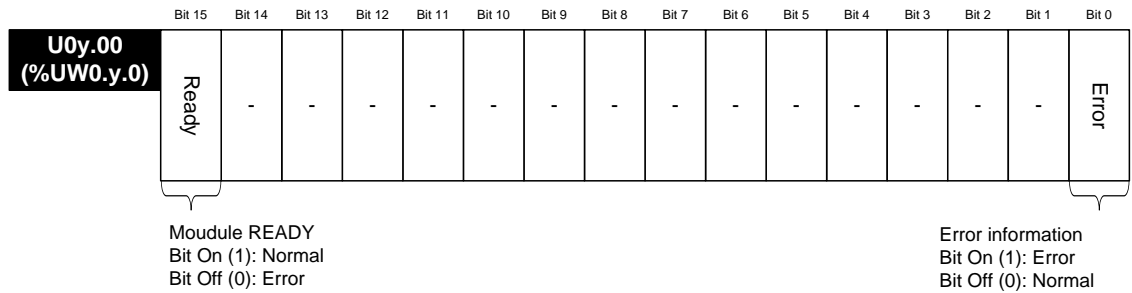

- 2) Run channel flag ( ' ( ) ' means the case of IEC type, y: slot number)
 

The area where Run information of respective channels is saved

\* XGB series base number is 0.

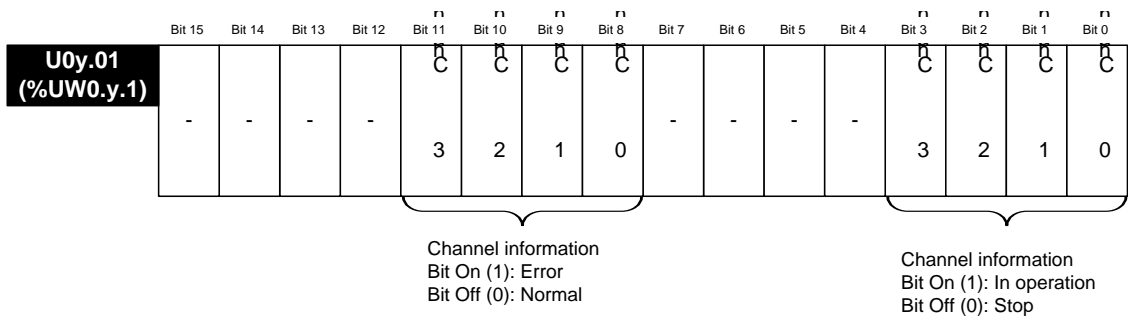

- 3) Digital output value ( ' ( ) ' means the case of IEC type, y: slot number)
  - (1) A/D converted-digital output value will be output to buffer memory addresses UXY.02 ~ UXY.05 (%UW0.x.2 ~ %UW0.x.5) for respective channels.
  - (2) Digital output value will be saved in 16-bit binary.

※ XGB PLC's base number is 0.

Bit 15	Bit 14	Bit 13	Bit 12	Bit 11	Bit 10	Bit 9	Bit 8	Bit 7	Bit 6	Bit 5	Bit 4	Bit 3	Bit 2	Bit 1	Bit 0
<b>U0y.02 (%UW0.y.2)</b>															
Channel 0 conversion value															
<b>U0y.03 (%UW0.y.3)</b>															
Channel 1 conversion value															
<b>U0x.04 (%UW0.x.4)</b>															
Channel 2 conversion value															
<b>U0x.05 (%UW0.x.5)</b>															
Channel 3 conversion value															

- 4) Input disconnection flag (( ) means the case of IEC type, y: slot number)  
 The area where the input disconnection detection signal of each channel is saved.  
 U0y.10.0 ~ U0y.10.3 (%UX0.y.160 ~ %UX0.y.163)  
 ※ XGB PLC's base number is 0.

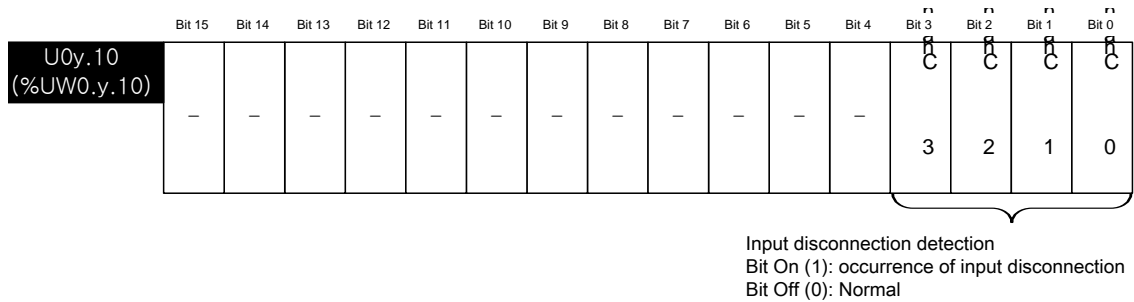

- 5) High limit alarm flag (( ) means the case of IEC type, y: slot number)  
 The area where the high limit alarm detection signal of each channel is saved.  
 U0y.11.0 ~ U0y.11.3 (%UX0.y.176 ~ %UX0.y.179)  
 ※ XGB PLC's base number is 0.

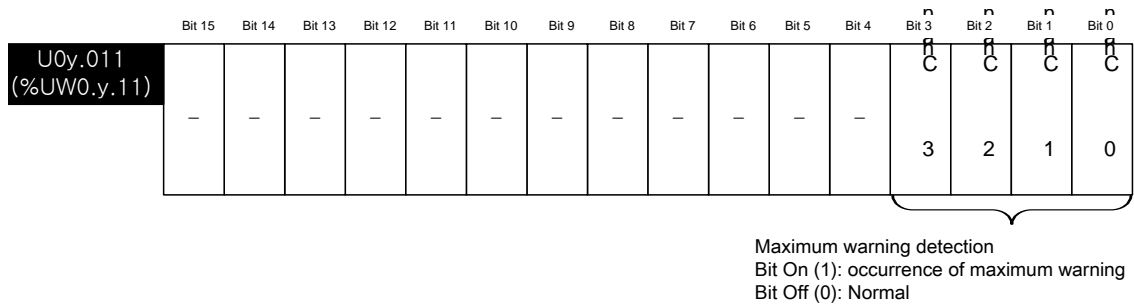

- 6) Low limit alarm flag (( ) means the case of IEC type, y: slot number)  
 The area where the low limit alarm detection signal of each channel is saved.  
 U0y.12.0 ~ U0y.12.3 (%UX0.y.192 ~ %UX0.y.195)  
 ※ XGB PLC's base number is 0.

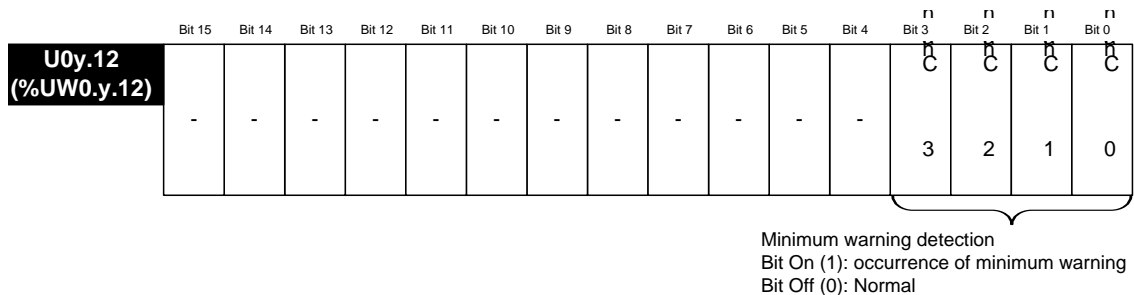

**Notes**

(1) If the external 24V power is not provided, operating channel information [U0y.01.0~U0y.01.3 (%UX0.y.16 ~ %UX0.y.19)], input disconnection flag [U0y.10.0~U0y.10.3(%UX0.y.160~ %UX0.y.163)], high limit alarm flag [U0y.11.0~U0y.11.3(%UX0.y.176~%UX0.y.179)], low limit alarm flag [U0y.12.0~U0y.12.3 (%UX0.y.192 ~ %UX0.y.195)] will be off.



## 13.11.2 Operation parameters setting area

Setting area of A/D conversion module's Run parameters is as described in Table.

Memory address	Descriptions	Details	R/W	Remark
0	Specify channel to use	Bit 0 ~ Bit 3 0: Stop, 1: Run	R/W	PUT/GET
1	Specify range of input voltage/current	Input range setting (4 Bits) 0000 : 4 ~ 20mA 0001 : 0 ~ 20mA 0010 : 1 ~ 5 V 0011 : 0 ~ 5 V 0100 : 0 ~ 10 V 0101 : -10 ~ 10V	R/W	
3	Specify range of output data	Output data format setting (2 Bit) 00: 0 ~ 16,000 01: -8,000 ~ 8,000 10: Precise value 11: 0 ~ 10,000 - In case of precise value 4 ~ 20mA: 4,000 ~ 20,000 0 ~ 20mA: 0 ~ 20,000 1 ~ 5V: 1,000 ~ 5,000 0 ~ 5V: 0 ~ 5,000 0 ~ 10V: 0 ~ 10,000 -10 ~ 10V: -10,000 ~ 10,000	R/W	
4	CH0 filter constant	0 or 4 ~ 64,000	R/W	
5	CH1 filter constant			
6	CH2 filter constant			
7	CH3 filter constant			
12	Specify average processing method	Average process (2 Bits) 00 : Sampling process 01 : Time average process 10 : Number of average process	R/W	
13	CH0 average value	Input channe average type setting Time average : 4 ~ 16,000 [ms] Count average : 2 ~ 64,000 [times]	R/W	
14	CH1 average value			
15	CH2 average value			
16	CH3 average value			
21	Hold last value	Bit 0 ~ Bit 3 0: Disable, 1: Enable	R/W	
22	Setting error	0-3: CH 0-3 (10Dec, #: Channel No.) 10#: Channel range over 20#: Filter constant range over 30#: Average constant range over	R/W	GET

**Notes**

- (1) When memory addresses of 1, 4~7, 13~16 areas are entered from external setting values, U0y.01.8~U0y.01.B (representative flag of setting error, in case of IEC type) is on and operates with basic setting value. Error information is shown on error information area(No. 22).
- (2) The system area (after No. 23 ) is prohibited for reading/writing. If this area is changed, malfunction and breakdown can be made.

1) Setting operation channels

If the channel to use is not specified, all the channels will be set to Prohibited.

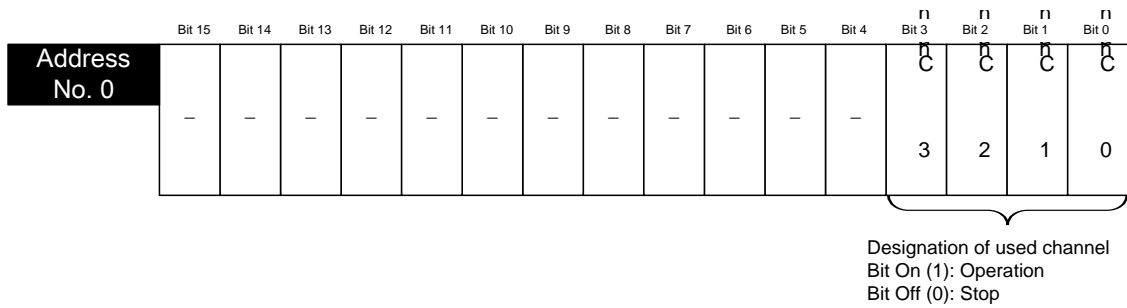

2) Setting input range

(1) The range of analog input voltage are DC 1~5V, DC 0~5V, DC 0~10V, DC -10~10V, the range of analog current input are DC 4~20mA, DC 0~20mA.

(2) When the input range is not set, it is handled as range of DC 4~20mA.

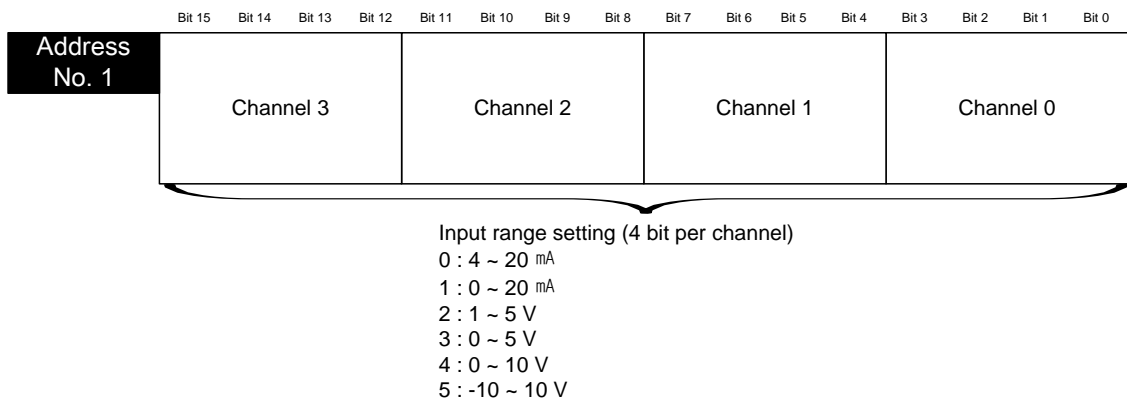

3) Setting output data type

(1) The range of digital output data for analog input can be specified for respective channels.

(2) If the output data range is not specified, the range of all the channels will be set to 0 ~ 16000.

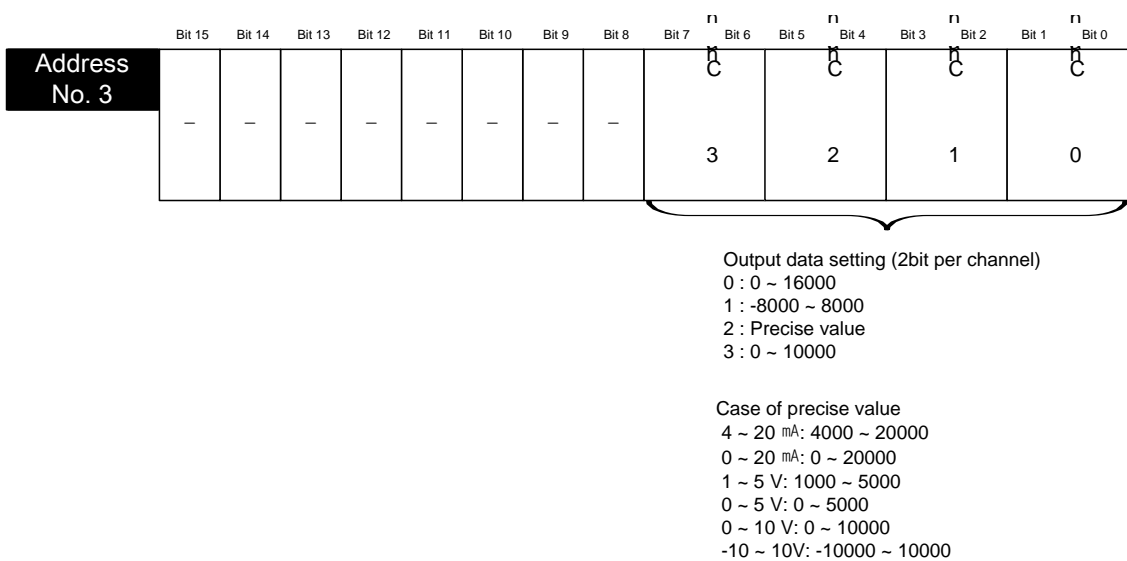

4) Setting filter constant

- (1) When the filter constant is specified with 0, the filter will not be operated.
- (2) If the filter constant is not specified with anything, it can't filter and it will be handled in 0.

	Bit 15	Bit 14	Bit 13	Bit 12	Bit 11	Bit 10	Bit 9	Bit 8	Bit 7	Bit 6	Bit 5	Bit 4	Bit 3	Bit 2	Bit 1	Bit 0
Address No. 4	Channel 0 filter constant (0 or 4 ~ 64000 ms)															
Address No. 5	Channel 1 filter constant(0 or 4 ~ 64000 ms)															
Address No. 6	Channel 2 filter constant(0 or 4 ~ 64000 ms)															
Address No. 7	Channel 3 filter constant(0 or 4 ~ 64000 ms)															

5) Setting average process method

- (1) When setting average process, the average process method is selected among time average, number of averages, moving average.
- (2) If setting average process is not specified, all channels will not handle the average process.

	Bit 15	Bit 14	Bit 13	Bit 12	Bit 11	Bit 10	Bit 9	Bit 8	Bit 7	Bit 6	Bit 5	Bit 4	Bit 3	Bit 2	Bit 1	Bit 0
Address No. 12	-	-	-	-	-	-	-	-	-	n C	n C	n C	n C			
										3	2	1	0			

Designation of average processing method(2bit per channel)  
 0 : Sampling processing  
 1 : Time average processing  
 2 : Average of number of rocessing

6) Setting average value

- (1) The average value is set depending on setting area of average process method.
- (2) When the average value is out of the setting area, the average process will not be made.

	Bit 15	Bit 14	Bit 13	Bit 12	Bit 11	Bit 10	Bit 9	Bit 8	Bit 7	Bit 6	Bit 5	Bit 4	Bit 3	Bit 2	Bit 1	Bit 0
Address No. 13	Channel 0 average value															
Address No. 14	Channel 1 average value															
Address No. 15	Channel 2 average value															
Address No. 16	Channel 3 average value															

Input channel average value setting  
 Time average : 4 ~ 16000 [ms]  
 Number of average : 2 ~ 64000 [times]

7) Maintaining valid conversion value

- (1) In case that retaining valid conversion value is set at the same time, if the invalid value is come, the late valid value will only be retained. For example, firstly, it is operated with 4 ~20mA. Secondly, 10mA comes in. Finally, the signal is immediately falling down to 3mA without falling down the current continually. In this case, relevant channels will retain the output value of 10mA.
- (2) When this function is set, digital output value related with actual range of analog input is only shown. Refer to the actual range of the analog from "chapter 13.4".
- (3) This function can only be operated within input range.
  - 1) 4 ~ 20mA
  - 2) 0 ~ 20mA
 Refer to the using method from "chapter 13.6.5" for detail..
- (4) Setting of retaining valid conversion value is as below.

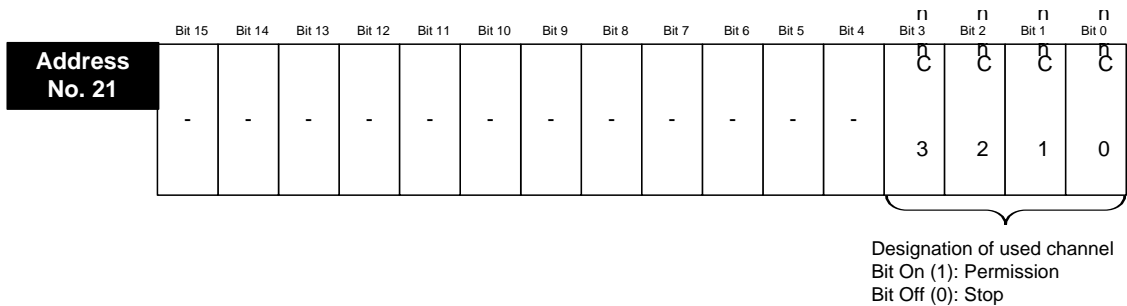

8) Error code

- (1) It saves the error code detected from A/D conversion module.
- (2) Error type and details is as below.

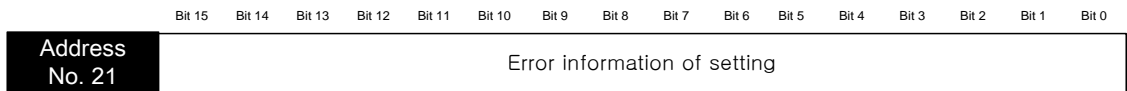

Type	Error code	LED sign	Details	Priority of error code	Remarks for reference
Error	10#	LED	Setting error of channel range	1	'#' is the number of CH 1~3
	20#	Flickering	Setting error of channel filter value	2	
	30#	1s intervals	Setting error of channel average value	3	

- (3) When errors of two or more are caused, the high priority error code is saved. And when the same error code is caused in channels of two or more, the error code of low channel number is saved preferentially.

9) System area (after No. 23)

- (1) The system area (after No. 23) is prohibited for reading/writing.

**Caution**

▶ If this area is changed, the product can malfunction and be broken.

## 13.12 Example Program

- (1) Setting of operation parameter of analog input module is explained.
- (2) The initial setting condition is saved in internal memory of the analog input module by inputting once.
- (3) As below, these example programs are that the analog input modules of the slot No. 1 control the output data of the analog input module and detect whether wire is disconnect.

### 13.12.1 Analog input program

#### 1) Setting I/O parameter

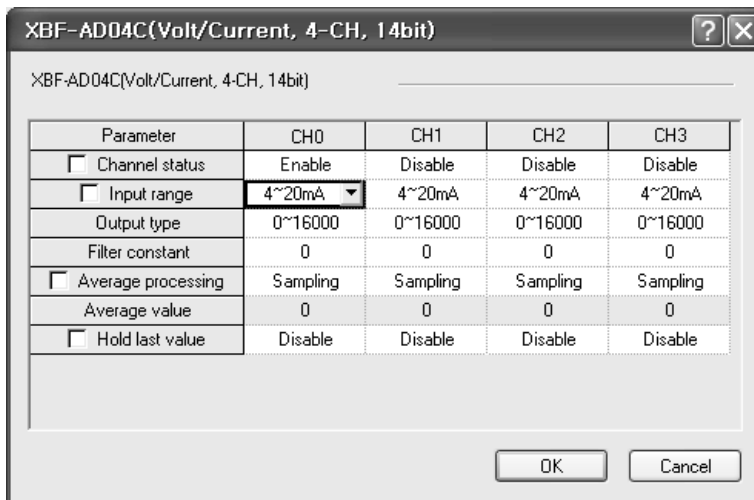
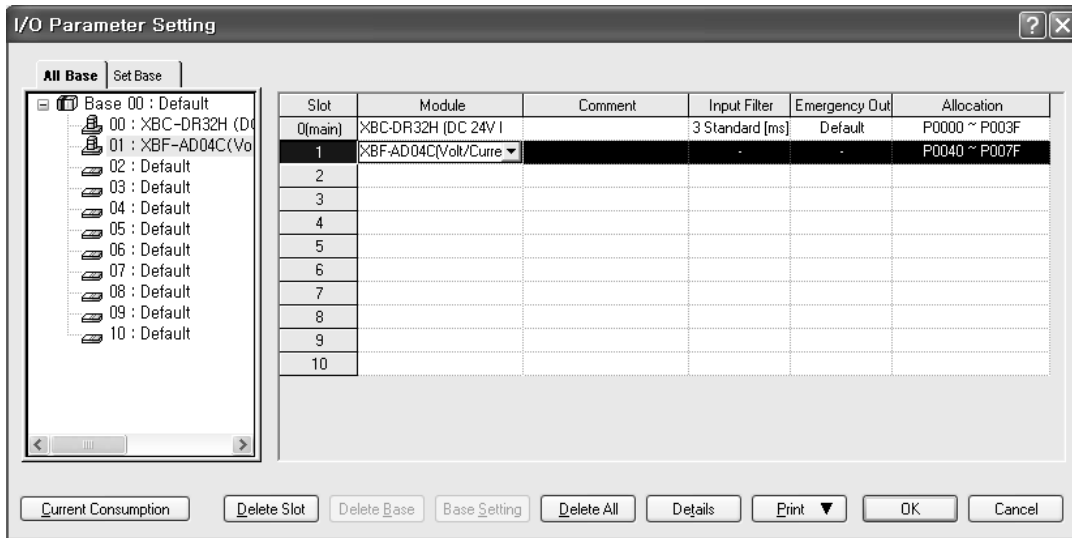

- (1) The channel 0 is set with operation channel, the ranges are set with 4~20mA.

2) Example program

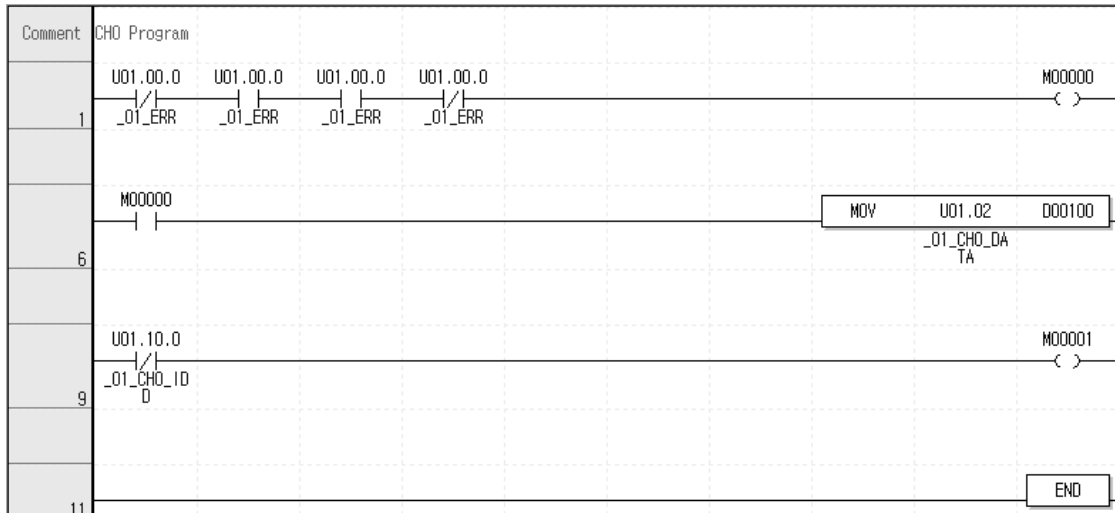

- (1) The 'M0000' is on while the module normally operates.  
 U01.00.0(Module Error) = Off  
 U01.00.F(Module Ready) = On  
 U01.01.0(CH0 Run) = On  
 U01.01.8(CH0 Error) = Off
- (2) When the 'M0000' is on, conversion value (U01.02) of CH0 is moved to the 'D00100'.
- (3) If the error is caused on CH0, U01.10.0 Bit(CH0 disconnection) and the M00001 will be on.

3) Example Program (In case of IEC)

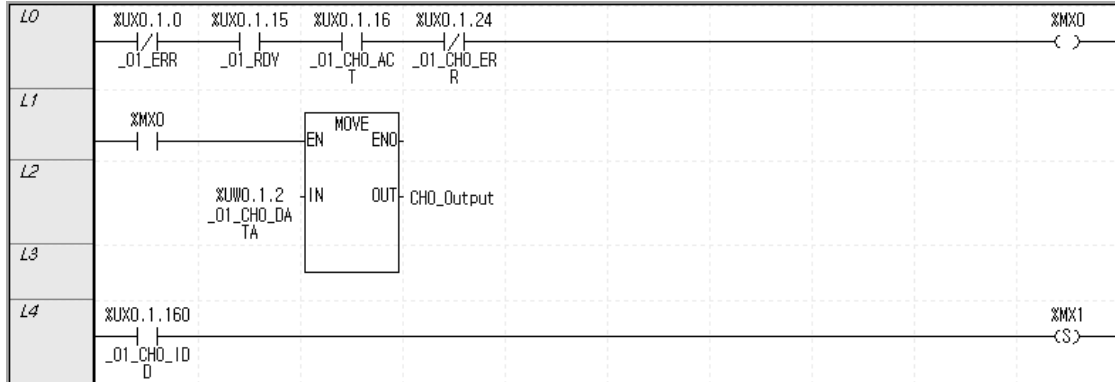

- (1) If the module operation is normal, the '%MX0' will be on.  
 %UX0.1.0(Module Error) = Off  
 %UX0.1.15(Module Ready) = On  
 %UX0.1.16(CH0 Run) = On  
 %UX0.1.24(CH0 Error) = Off
- (2) If the '%MX0' is on, conversion value (%UW0.1.2) of CH0 will be moved to the variable of "input value of CH0".
- (3) If the disconnection error of CH0 is caused, %UX0.1.160 (CH0 disconnection) and the 'MX1' Bit will be on.

## 13.13 Breakdown test

Explain the test and measure method of breakdown while using the analog input module.

### 13.13.1 Checking the LED status in case of error

The analog input module has a LED and is able to check whether there is error of the module through the sign of LED.

Item	Normal Status	When CH is disconnected (Input)	When parameter setting is error
LED	Light on	Flickering 1s intervals	Flickering 1s intervals (When the input parameter setting is error)
Module Operation	Normal operation Operation of all functions	Operation of all functions Sign of minimum input value	Operation of all functions (Operation by basic value of parameter)
Measure	-	Check wiring	Check parameter setting

### 13.13.2 Check the module status

The status of analog input module (Module type/information/OS version) can be checked through the system monitor of XG5000.

#### 1) The order of execution

It can be implemented through one of the methods among next items.

- (1)[Monitor] -> [System Monitor] -> Click the right button of mouse on the painting of module.  
-> [Module Information]
- (2)[Monitor] -> [System Monitor] -> Double click the painting of module
- (3)[Monitor] -> [Special Module Monitor] -> [XBF-AD04C] Selection ->Click the module information
- (4)[Online] -> [I/O Information] -> [XBF-AD04C] Selection -> Click the details
- (5)[Online] -> [I/O Information] -> [XBF-AD04C] Double click

#### 2) Module information

- (1) Module Name: Information of recently equipped module device is shown.
- (2) OS Version: OS version of module is shown.
- (3) OS Update Date: The OS prepared date of module is shown.
- (4) Module status: The present error code is shown.

13.13.3 Check and Measure the breakdown

1) The LED is turned off.

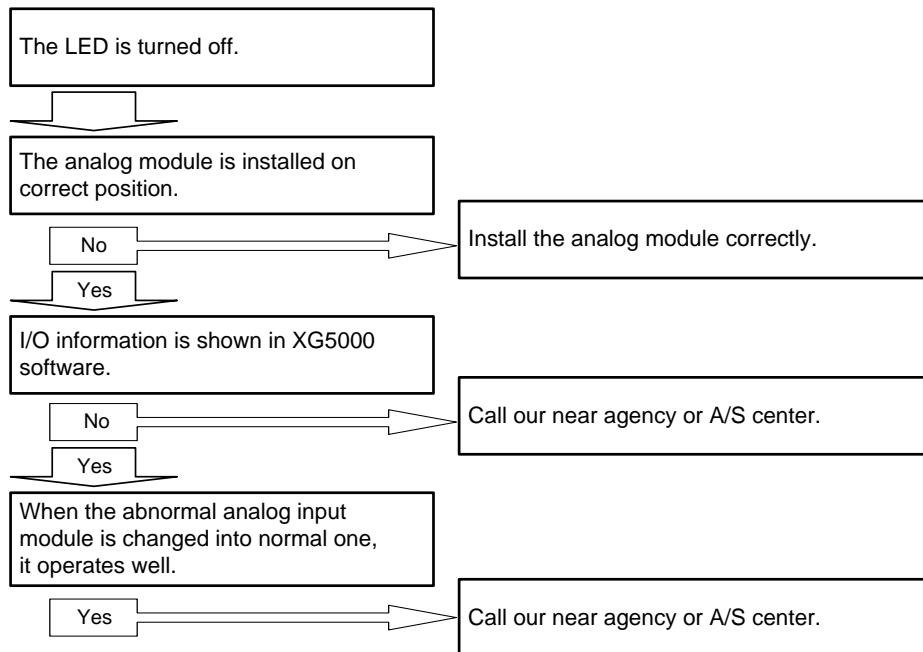

2) The LED is flickering.

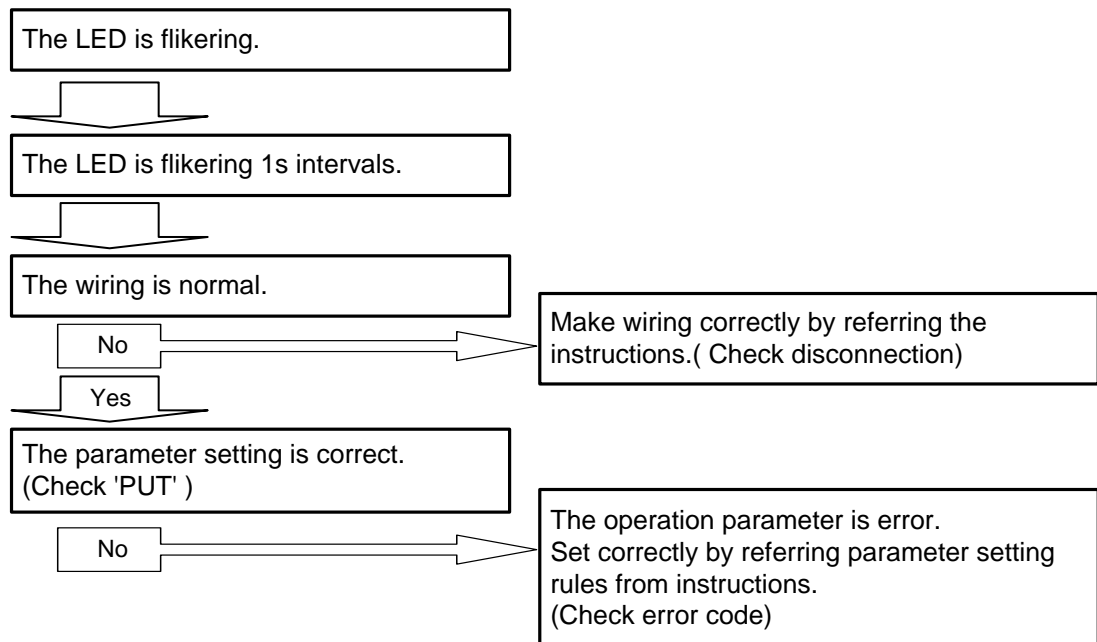



3) The analog input value is abnormal.

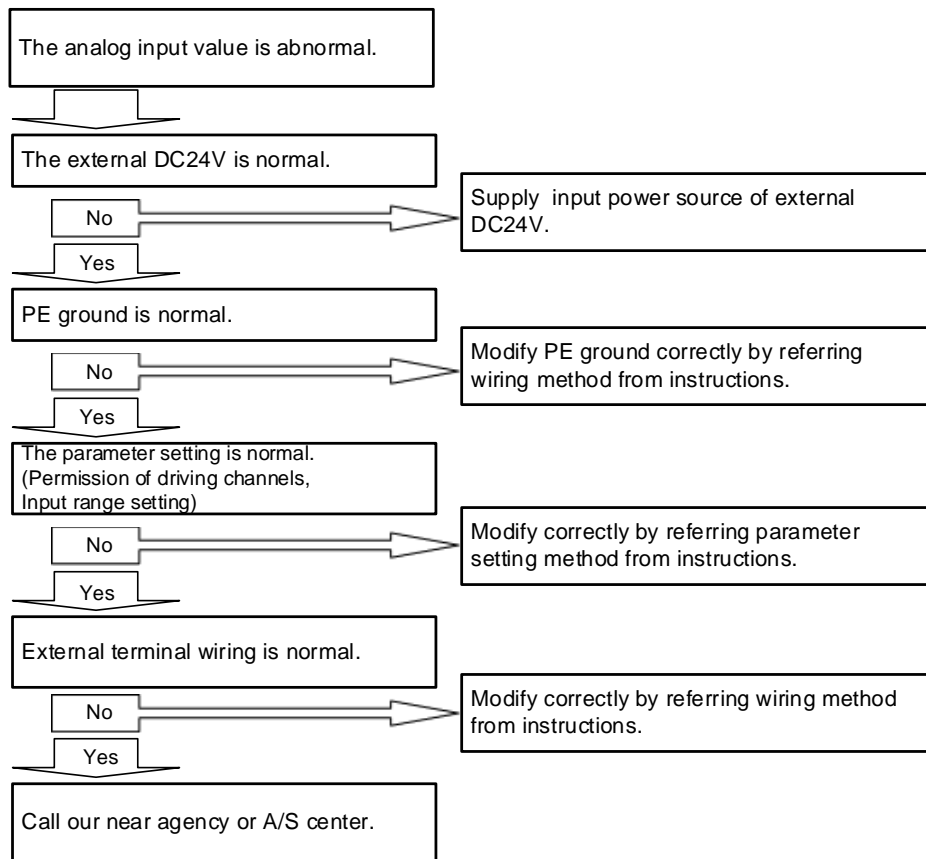

# Chapter 14 Analog Output Module (XBF-DV04C/XBF-DC04C)

## 14.1 Setting Sequence before Operation

Before using the analog input module, follow steps below.

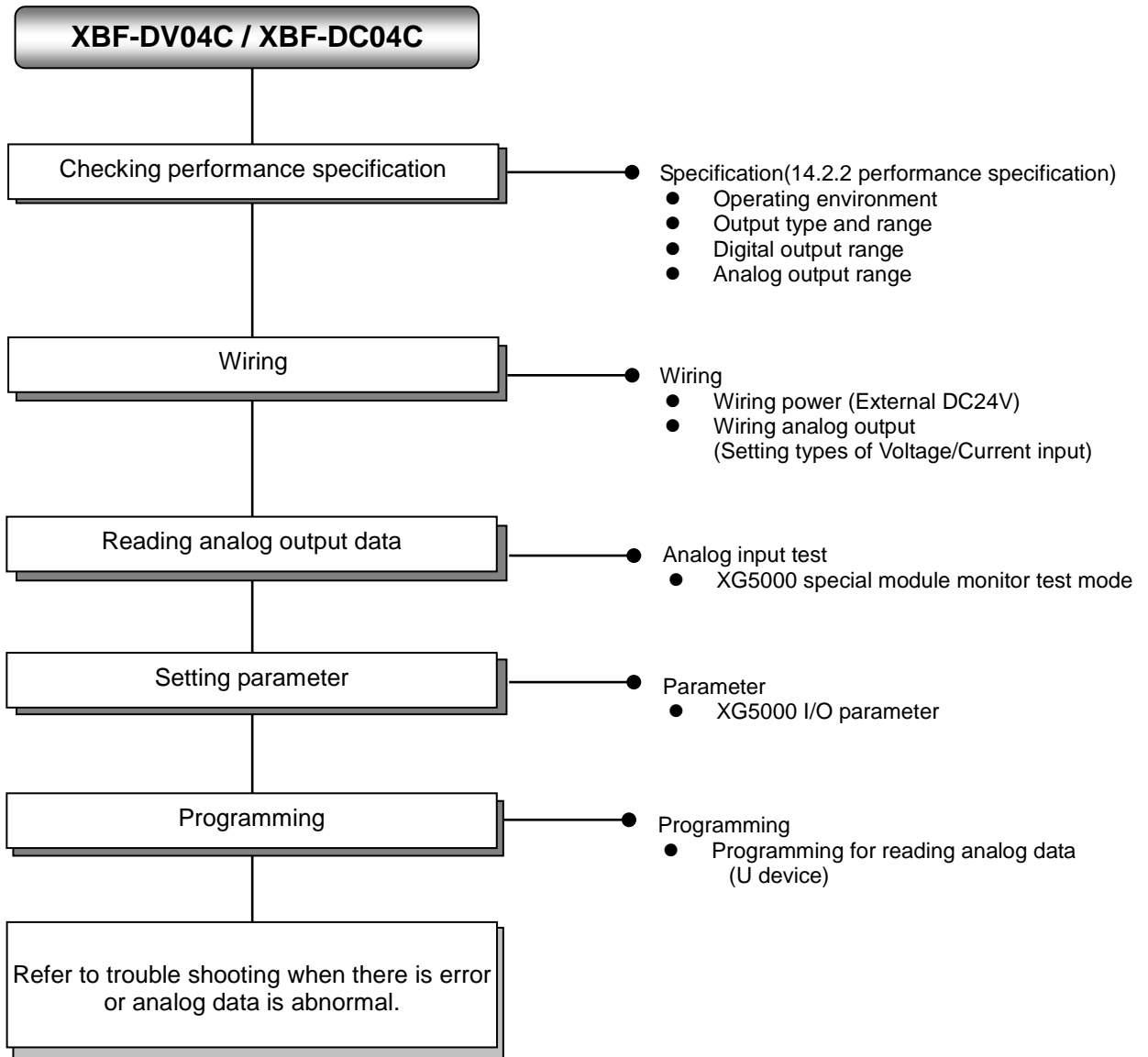

## 14.2 Specifications

### 14.2.1 General specifications

General specifications are as follows.

No.	Item	Specifications	Related specifications				
1	Ambient temperature	0 °C ~ +55 °C	-				
2	Storage temperature	-25 °C ~ +70 °C	-				
3	Ambient humidity	5 ~ 95%RH (Non-condensing)	-				
4	Storage humidity	5 ~ 95%RH (Non-condensing)	-				
5	Vibration resistance	Occasional vibration			-	10 times each directions (X, Y and Z)	IEC61131-2
		Frequency	Acceleration	Amplitude	How many times		
		5 ≤ f < 8.4 Hz	-	3.5 mm			
		8.4 ≤ f ≤ 150 Hz	9.8 m/s <sup>2</sup> (1G)	-			
		For continuous vibration					
		Frequency	Acceleration	Amplitude			
		5 ≤ f < 8.4 Hz	-	1.75 mm			
8.4 ≤ f ≤ 150 Hz	4.9 m/s <sup>2</sup> (0.5G)	-					
6	Shock resistance	<ul style="list-style-type: none"> <li>Peak acceleration: 147 m/s<sup>2</sup>(15G)</li> <li>Duration: 11ms</li> <li>Half-sine, 3 times each direction per each axis</li> </ul>	IEC61131-2				
7	Noise resistance	Square wave Impulse noise	AC: ± 1,500V DC: ± 900V	LSIS standard			
		Electrostatic discharge	Voltage : 4kV (contact discharging)	IEC 61131-2, IEC 61000-4-2			
		Radiated electromagnetic field noise	80 ~ 1,000 MHz, 10V/m	IEC 61131-2, IEC 61000-4-3			
		Fast transient /bust noise	Segment Power supply module Voltage 2kV	Digital/analog input/output communication interface 1kV	IEC 61131-2, IEC 61000-4-4		
8	Environment	Free from corrosive gasses and excessive dust	-				
9	Altitude	Up to 2,000 ms	-				
10	Pollution degree	Less than equal to 2	-				
11	Cooling	Air-cooling	-				

## 14.2.2 Performance specifications

Performance specifications are as follows.

Items		Performance specification		
		XBF-DV04C	XBF-DC04C	
Channels		4 channels		
Analog output range	Type	Voltage	Current	
	Range	DC 1 ~ 5V DC 0 ~ 5V DC 0 ~ 10V DC -10 ~ 10V (Load resistance: 1k $\Omega$ or more)	DC 4 ~ 20mA DC 0 ~ 20mA (Load resistance: 600 $\Omega$ or less)	
	Output ranges are set in user program or I/O parameter per each channel.			
Digital input	Type	16 bit binary data (Data : 14Bit)		
	Range	Unsigned value	0 ~ 16,000	
		Signed value	-8,000 ~ 8,000	
		Precise value	1,000 ~ 5,000 (1 ~ 5V) 0 ~ 5,000 (0 ~ 5V) 0 ~ 10,000 (0 ~ 10V) -10,000 ~ 10,000 ( $\pm$ 10V)	4,000 ~ 20,000 (4 ~ 20mA) 0 ~ 20,000 (0 ~ 20mA)
		Percentile value	0 ~ 10,000	
Max. resolution		1/16,000		
		0.250mV (1 ~ 5V) 0.3125mV (0 ~ 5V) 0.625mV (0 ~ 10V) 1.250mV ( $\pm$ 10V)	1.0 $\mu$ A (4 ~ 20mA) 1.25 $\mu$ A (0 ~ 20mA)	
Accuracy		$\pm$ 0.2% or less (When ambient temperature is 25 $^{\circ}$ C) $\pm$ 0.3% or less (When ambient temperature is 0 ~ 55 $^{\circ}$ C)		
Max. conversion speed		1ms/ channel		
Additional function		Setting of channel output status (Select one among previous, Min, Max value) Setting of interpolation method (Linear interpolation, S-type interpolation)		
Insulation method		Photo-coupler insulation between output terminal and PLC power (no insulation between channels)		
Terminal connected		11 point terminal		
I/O occupied points		Fixed point assignment: 64 points		
Max. attachable number		7 [When using XBM-Dxxx $\square$ ( $\square$ : "S", "H", "H2", "HP") type] 7 (when using XB(E)C-DxxxSU type) 10 (when using XB(E)C-DxxxH type or XB(E)C-DxxxU type) Not Available (when using XB(E)C-DxxxE type)		
Weight		68g	69g	
Consumed current	Internal (DC 5V)	70mA		
	External (DC 24V)	160mA		
Power Supply		DC 20.4V ~ 28.8V		

Remark 1) To use the analog input module (14 Bit), It needs the basic unit more than below table.

Segment	Version
XBM-DxxxS Type	V3.30 or above
XBC-DxxxH Type	V2.20 or above
XBC-DxxxSU Type	V1.30 or above
XBC-DxxxS Type	V1.20 or above
XEC-DxxxH Type	V1.50 or above
XEC-DxxxSU Type	V1.10 or above
XG5000	V3.64 or above

### 14.3 Name of each Part and Functions

Respective designations of the parts are as described below.

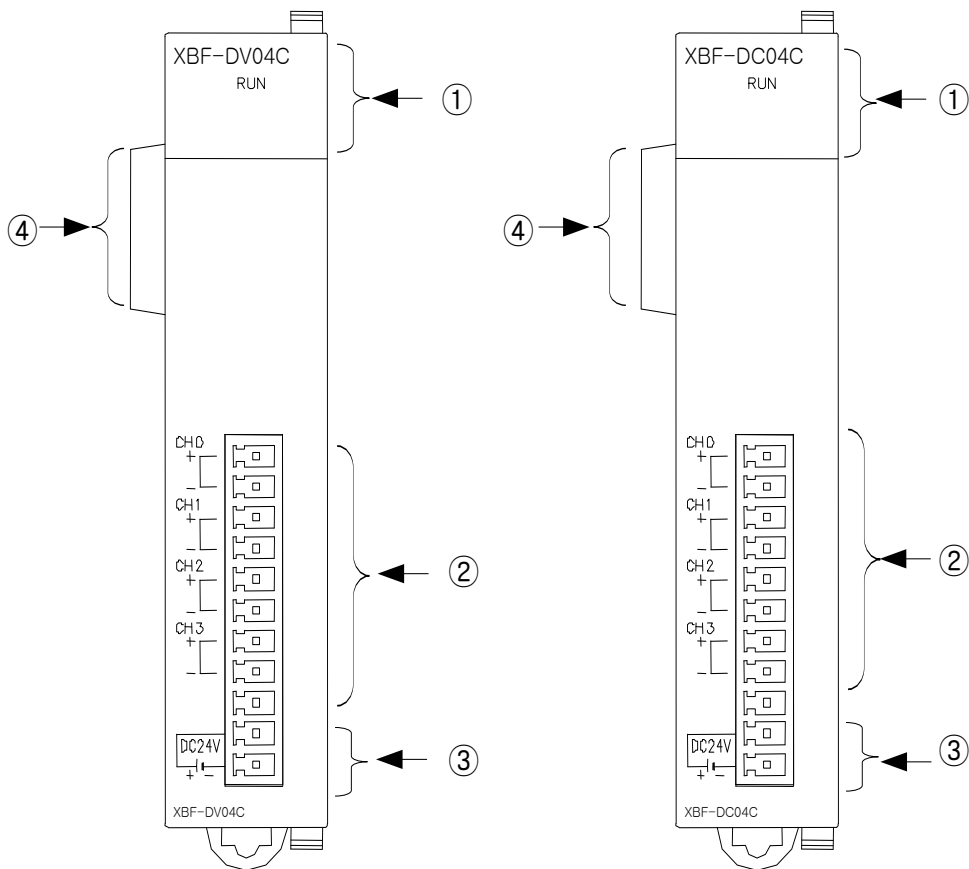

No.	Name	Description
①	RUN LED	<ul style="list-style-type: none"> <li>▶ Displays the operation status of analog output module</li> <li>On: Normal operation</li> <li>Flickers: Error occurs (Flickering 1s intervals)</li> <li>Off: Power off or Module error</li> </ul>
②	Terminal block	<ul style="list-style-type: none"> <li>▶ Analog output(voltage, current) terminal, whose respective channels can be connected with external devices</li> </ul>
③	External power supply terminal	<ul style="list-style-type: none"> <li>▶ Terminal for supplying the external DC24V</li> </ul>
④	Ext. Connector	<ul style="list-style-type: none"> <li>▶ Connector for extension modules</li> </ul>

## 14.4 Conversion Characteristic of each Output Range

The output conversion characteristic is described by graphs as follows after changing digital input set from XBG basic unit to analog output (Voltage, Current).

In the digital input range, there are four kinds of value. Those are unsigned value, signed value, precise value, percentile value.

I/O conversion characteristic is as follows depending on each range of digital input.

### 1) Conversion characteristic of analog output module (XBF-DV04C)

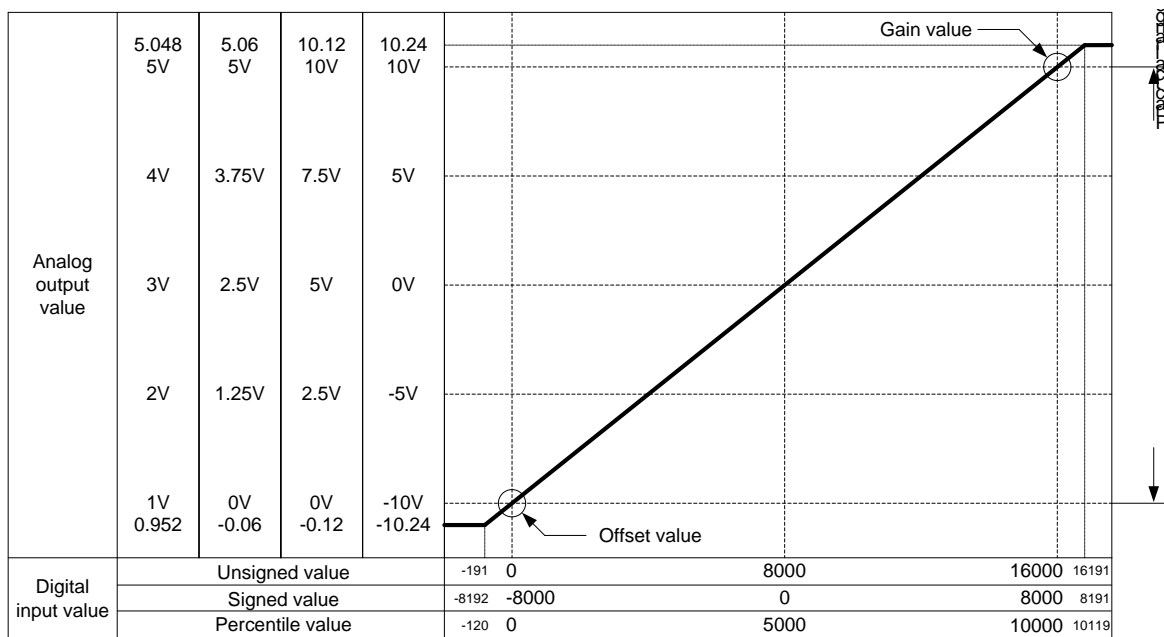

#### (1) DC 1 ~ 5V Output range

Digital input	Analog output voltage (V)						
	0.952	1	2	3	4	5	5.047
Unsigned value (-192 ~ 16,191)	-192	0	4,000	8,000	12,000	16,000	16,191
Signed value (-8,192 ~ 8,191)	-8,192	-8,000	-4,000	0	4,000	8,000	8,191
Precise value (952 ~ 5,047)	952	1,000	2,000	3,000	4,000	5,000	5,047
Percentile value (-120 ~ 10,119)	-120	0	2,500	5,000	7,500	10,000	10,119

#### (2) DC 0 ~ 5V Output range

Digital value	Analog output voltage (V)						
	-0.06	0	1.25	2.5	3.75	5	5.059
Unsigned value (-192 ~ 16,191)	-192	0	4,000	8,000	12,000	16,000	16,191
Signed value (-8,192 ~ 8,191)	-8,192	-8,000	-4,000	0	4,000	8,000	8,191
Precise value (-60 ~ 5,059)	-60	0	1,250	2,500	3,750	5,000	5,059
Percentile value (-120 ~ 10,119)	-120	0	2,500	5,000	7,500	10,000	10,119

(3) DC 0 ~ 10V Output range

Digital input	Analog output voltage (V)						
	-0.12	0	2.5	5	7.5	10	10.119
Unsigned value (-192 ~ 16,191)	-192	0	4,000	8,000	12,000	16,000	16,191
Signed value (-8,192 ~ 8,191)	-8,192	-8,000	-4,000	0	4,000	8,000	8,191
Precise value (-120 ~ 10,119)	-120	0	2,500	5,000	7,500	10,000	10,119
Percentile value (-120 ~ 10,119)	-120	0	2,500	5,000	7,500	10,000	10,119

(4) DC -10 ~ 10V Output range

Digital input	Analog output voltage (V)						
	-10.24	-10	-5	0	5	10	10.239
Unsigned value (-192 ~ 16,191)	-192	0	4,000	8,000	12,000	16,000	16,191
Signed value (-8,192 ~ 8,191)	-8,192	-8,000	-4,000	0	4,000	8,000	8,191
Precise value (-10,240 ~ 10,239)	-10,240	-10,000	-5,000	0	5,000	10,000	10,239
Percentile value (-120 ~ 10,119)	-120	0	2,500	5,000	7,500	10,000	10,119



2) Conversion characteristic of analog output module (XBF-DC04C: Current)

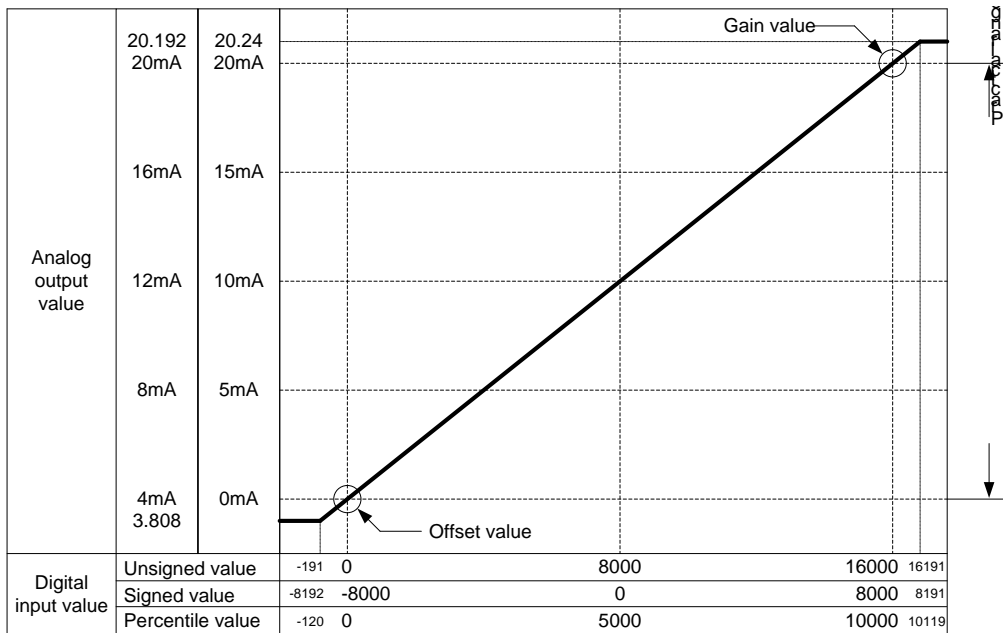

(1) DC 4 ~ 20mA Output range

Digital input range	Analog output current (mA)						
	3.808	4	8	12	16	20	20.191
Unsigned value (-192 ~ 16,191)	-192	0	4,000	8,000	12,000	16,000	16,191
Signed value (-8,192 ~ 8,191)	-8,192	-8,000	-4,000	0	4,000	8,000	8,191
Precise value (3,808 ~ 20,191)	3,808	4,000	8,000	12,000	16,000	20,000	20,191
Percentile value (-120 ~ 10,119)	-120	0	2,500	5,000	7,500	10,000	10,119

(2) DC 0 ~ 20mA Output range

Digital input range	Analog output current (mA)						
	-	0	5	10	15	20	20.239
Unsigned value (-192 ~ 16,191)	-	0	4,000	8,000	12,000	16,000	16,191
Signed value (-8,192 ~ 8,191)	-	-8,000	-4,000	0	4,000	8,000	8,191
Precise value (0 ~ 20,239)	-	0	5,000	10,000	15,000	20,000	20,239
Percentile value (-120 ~ 10,119)	-	0	2,500	5,000	7,500	10,000	10,119

## 14.5 Accuracy

Accuracy of digital output value does not change even if input range is changed. When digital input range is selected with unsigned value, accuracy is  $\pm 0.2\%$  (Ambient temperature of  $25 \pm 5 \text{ }^\circ\text{C}$ )

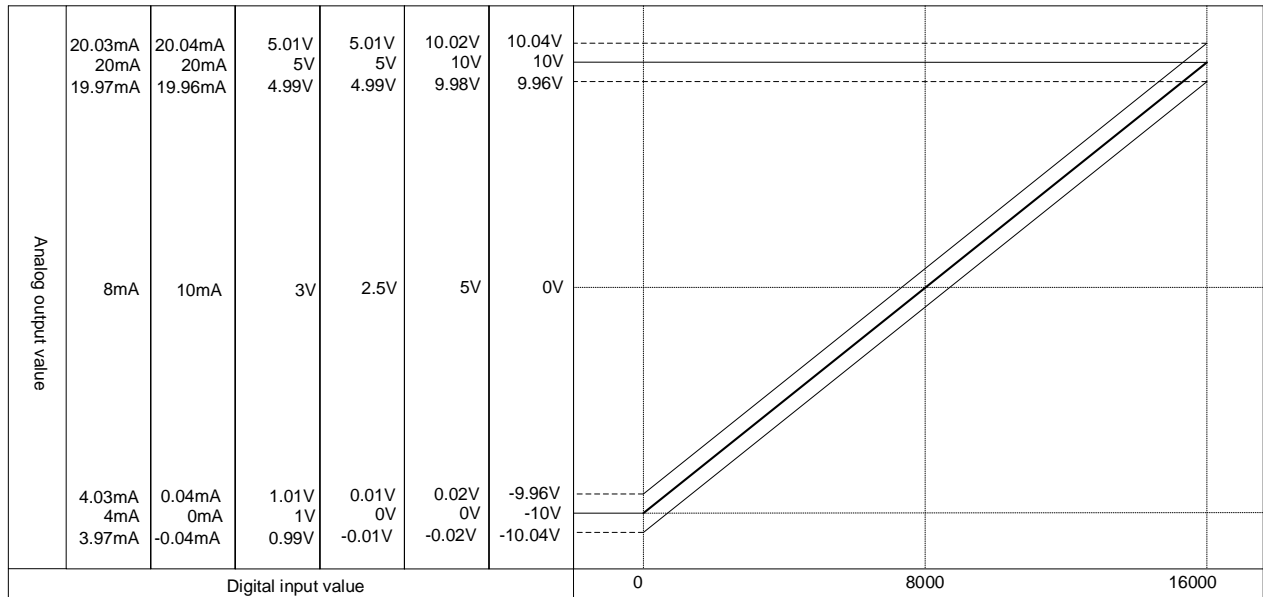

(1) Accuracy when using -10~10V output

$$16000 \times 0.2\% = 32$$

Accuracy range when using -10V output will become

$$(-10V - 32 \times 1.25\text{mV}) \sim (-10V + 32 \times 1.25\text{mV}) = -10.04 \sim -9.96\text{V},$$

Accuracy range when using 10V output will become

$$(10V - 32 \times 1.25\text{mV}) \sim (10V + 32 \times 1.25\text{mV}) = 9.96 \sim 10.04\text{V}$$

(2) Accuracy when using 4~20mA output

$$16000 \times 0.2\% = 32$$

Accuracy range when using 4mA output will become

$$(4\text{mA} - 32 \times 1\mu\text{A}) \sim (4\text{mA} + 32 \times 1\mu\text{A}) = 3.97\text{mA} \sim 4.03\text{mA}$$

Accuracy range when using 20mA output will become

$$(20\text{mA} - 32 \times 1\mu\text{A}) \sim (20\text{mA} + 32 \times 1\mu\text{A}) = 19.97\text{mA} \sim 20.03\text{mA}$$

## 14.6 Functions of Analog Output Module

Functions of XBF-DV04C / DC04C conversion module are as described below.

Function	Description
Channel Run/Stop setting	<ul style="list-style-type: none"> <li>Specify Run/Stop of channel to execute analog output.</li> <li>If the unused channel is set with Stop, whole operation time can be shorter.</li> </ul>
Range setting of the output data	<ul style="list-style-type: none"> <li>Set analog output range.</li> <li>The analog voltage output module provides four kinds of output ranges (DC 1~5V, DC 0~5V, DC 0~10V, DC -10~10V). And the analog current output module provides two kinds of output ranges (DC 4~20mA, DC 0~20mA).</li> </ul>
Range setting of the Input data	<ul style="list-style-type: none"> <li>Set digital input range.</li> <li>The four kinds of digital input ranges are provided. (Refer from 14.2.2)</li> </ul>
Channel output status	<ul style="list-style-type: none"> <li>Set the output status of channel when changing 'Run' to 'Stop'.</li> <li>The four kinds of output statuses (Previous, Min, Mid, Max value) are provided.</li> </ul>
Interpolation method setting	<ul style="list-style-type: none"> <li>Set linear interpolation, S-type interpolation method.</li> </ul>

### 14.6.1 Setting function of channel output status

Set the output against stop and abnormal condition of PLC.

#### 1) Function

When initialization of module and error of PLC system are happened, use to prevent abnormal output.

#### 2) Type

You can set an output status of channel among Previous, Min, Mid, Max value.

(1) Previous value: The last output operated normally is retained.

(2) Min: The Min value of each range is outputted.

(3) Mid: The Mid value of each range is outputted.

(4) Max: The Max value of each range is outputted.

#### 3) Example

When the range of output channel is set by 4 ~ 20mA and the output is 10mA, and then If the system is changed from 'Run' to 'Stop', the output will be as follows depending on setting data of channel output status.

(1) Previous value: 10mA which is previous output value is retained.

(2) Min value: 4mA which is min value of relevant range is outputted.

(3) Mid value: 12mA which is mid value of relevant range is outputted

(4) Max value: 20mA which is max value of relevant range is outputted.

### 14.6.2 Interpolation method setting

1) Functions

The output signal of module is used in order to execute interpolation output depending on set interpolation time. When the voltage and current is outputted, it can be used to prevent transient response of load system as a suddenly changed output.

2) Interpolation method setting

Interpolation method can set the one among interpolation prohibition, linear interpolation S-type interpolation.

(1) Interpolation prohibition : It doesn't execute interpolation operation.

And it outputs digital input value intactly.

(2) Linear interpolation : The output is changed up to objective value with linear during the interpolation time.

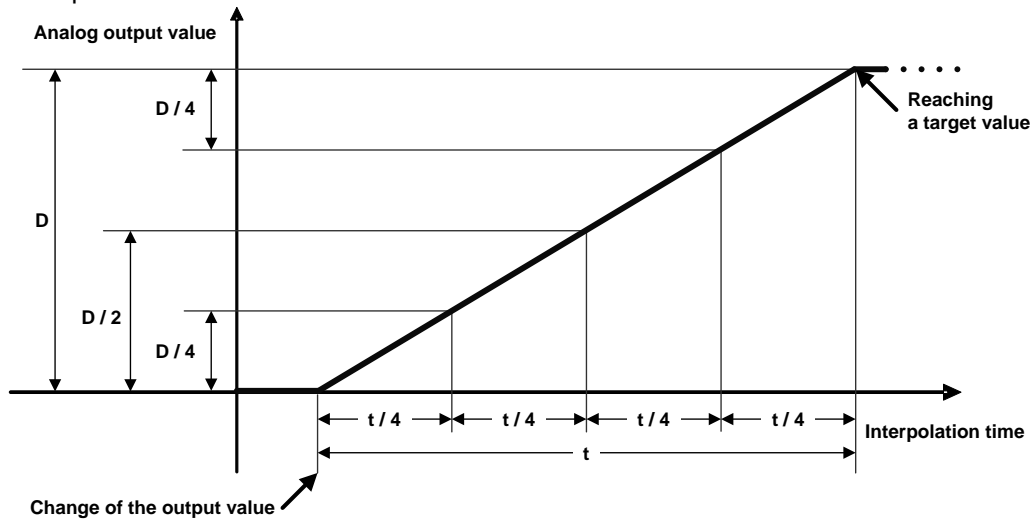

(3) S-type interpolation : The output is changed up to objective value with S-type during the interpolation time.

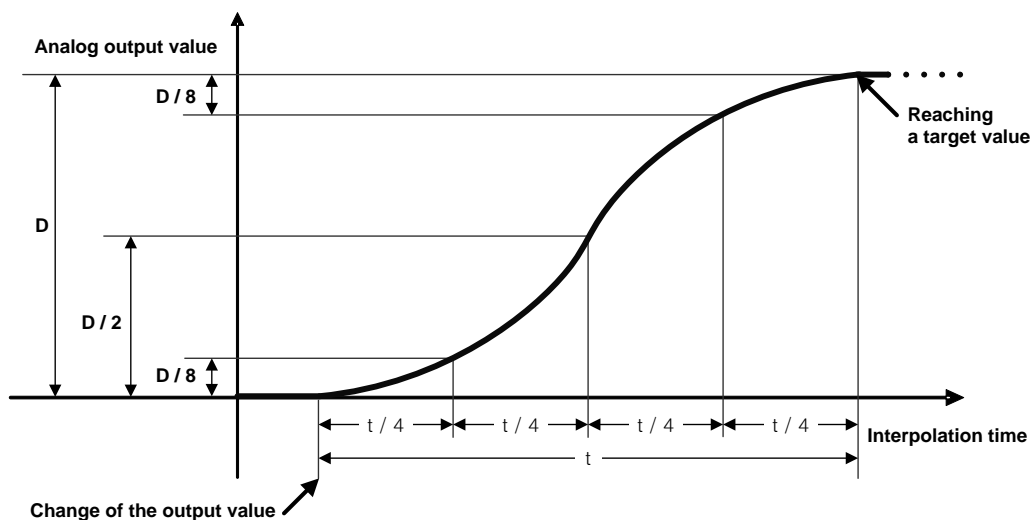

3) Interpolation time setting

The interpolation time can be set with the one among 10[ms], 100[ms], 1[s], 60[s]. The output is changed depending on interpolation method setting during the set interpolation time.

4) Interpolation output value

The interpolation operation value that is currently being outputted can check in parameter area (Address No. 17 ~ 20) while using interpolation function.

Address of interpolation output value	Details
No.17	Channel 0 interpolation operation value
No.18	Channel 1 interpolation operation value
No.19	Channel 2 interpolation operation value
No.20	Channel 3 interpolation operation value

5) Interpolation flag turns on while the interpolation is outputted. And when the interpolation output value is reached at objective value, It will turn off.

Interpolation flag	Details
U0y.01.8	Channel 0 interpolation output in operation
U0y.01.9	Channel 1 interpolation output in operation
U0y.01.A	Channel 2 interpolation output in operation
U0y.01.B	Channel 3 interpolation output in operation

6) Example

The output is changed from 4mA to 20mA and then when it is reached at 20mA, if the output comes back 4mA again, you have to do as follows.

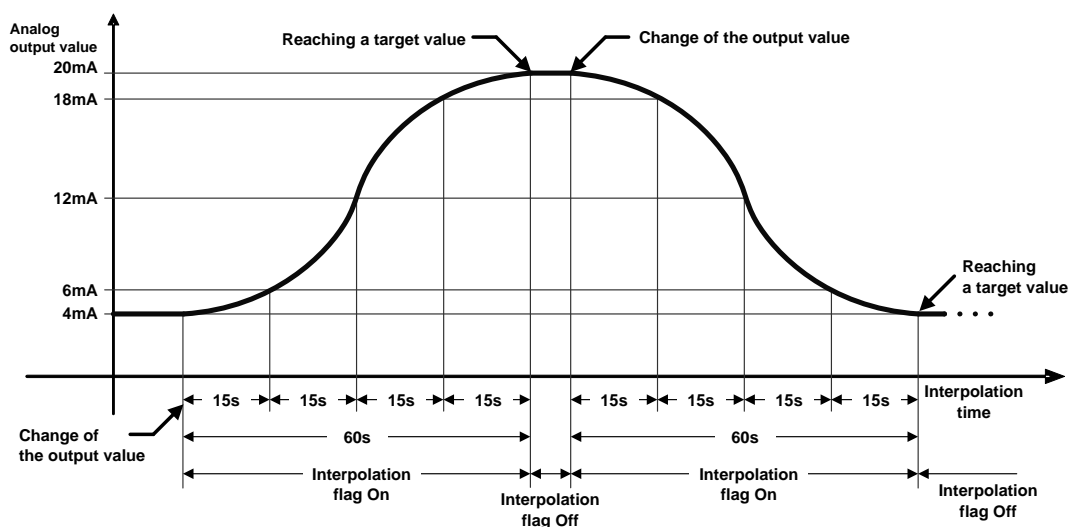

**Notes**

- 1) During the interpolation output, If the internal parameter is changed, the interpolation operation will be temporarily stopped and the output can be immediately changed to objective value.
- 2) If the change of internal parameter is needed, change the parameter during interpolation output after the flag turns off when the analog output value is not changed.

**14.6.3 Disconnection detecting function  
(Only for current output module XBF-DC04C)**

If the analog current output module detects disconnection of output, it can show the status of module.

In case that the module checks the disconnection and it is shown as the disconnection status, there are faulty in parts of wiring connection paths. Please check and take action.

- 1) In case that the disconnection between used output wiring and module is caused, LED can flicker 1s intervals and make an error flag.
- 2) The disconnection can be detected per each channel only for designed channels for operation. LED can use from channel 0 to 3 in common.  
If the one channel or more is disconnected, flickering will be generated.

Output connections	Channel operation	LED condition	Disconnection flag
Normal	Operation	On	Off
	Stop	On	Off
Output wiring is disconnected or Output is not connected	Operation	Flickering 1s intervals	On
	Stop	On	Off

- 3) If the disconnection is happened, disconnection flag of relevant channel will turn.  
However, if the disconnection is changed to connection, the disconnection flag will turn off.

Disconnection flag	Details
U0y.01.C	Channel 0 Disconnection
U0y.01.D	Channel 1 Disconnection
U0y.01.E	Channel 2 Disconnection
U0y.01.F	Channel 3 Disconnection

## 14.7 Installation and Wiring

### 14.7.1 Installation and separation of module

Notices in handling

Use the PLC within general specification ranges from instructions.

When the PLC is used out of the specified ranges, it will cause burning, getting electric shock, abnormal operation.

#### Caution

- ▶ Fix the module after being equipped with binding bump of module.  
If the module is incorrectly attached, the module will be broken and malfunction.
- ▶ Please be careful for external impact, like falling the case of module, terminal connector.
- ▶ Do not separate the PCB board of module from the case.

#### (1) Installation of module

- Remove the extension cover above the module to connect.
- Push modules to connect each other after situating four positions binding correctly.
- After connection, fix the binding hook that is in the upward part and downward part completely.

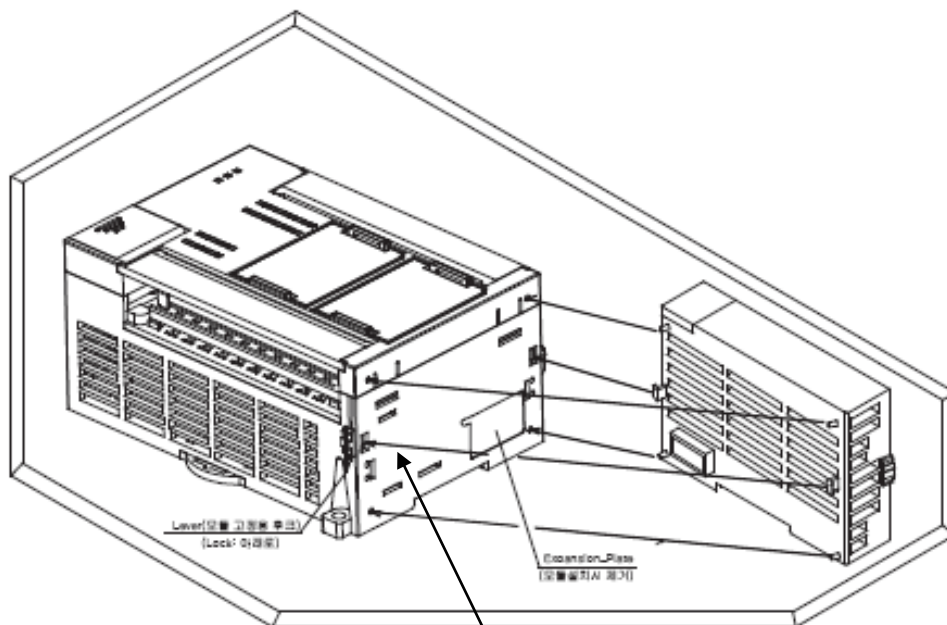

### (2) Separation of module

- Divide connections by lifting hook for module fixing in the upward part and downward part.
- Separate modules by holding modules with both hands. (Do not hold strongly in the module.)

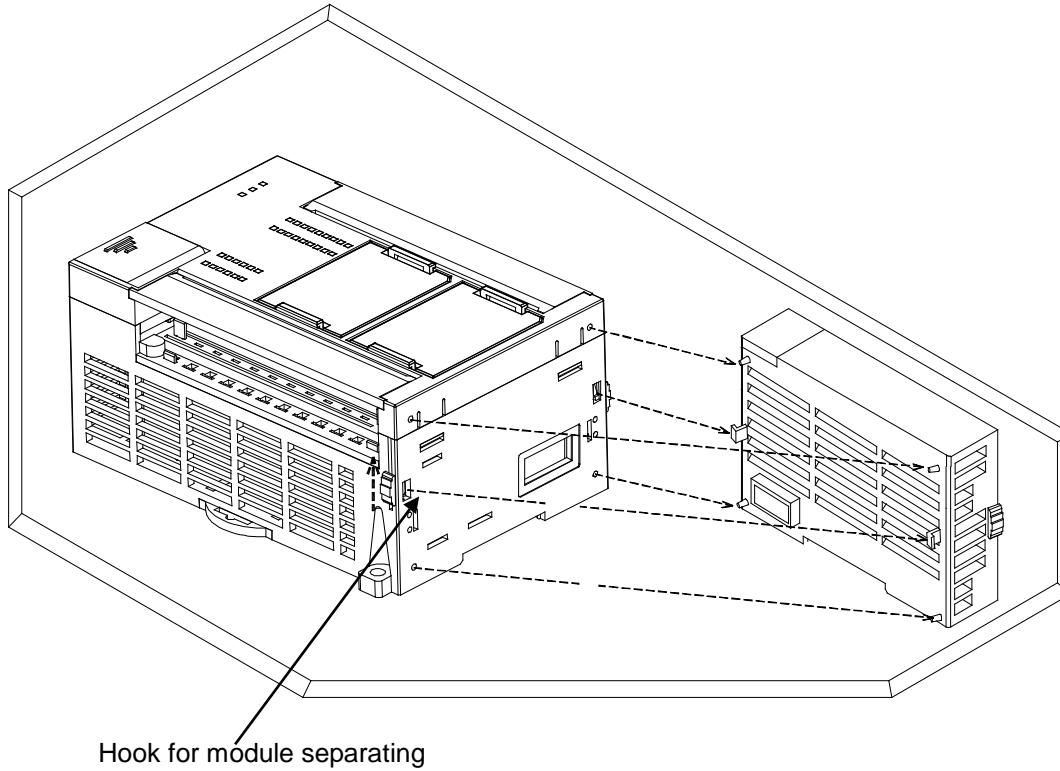

### ⚠ Caution

- ▶ When you try to separate the modules strongly, the hook and bump for fixing will be broken.



### 14.7.2 Notices in wiring

- (1) Do not put the power line near the external I/O signal line of analog input module. You have to secure enough distance to avoid the interruption from the induced noise and the surge.
- (2) The wire has to select by considering permitted current and the ambient temperature.  
The maximum wire size is good in case of AWG22 (0.3mm<sup>2</sup>) or more.
- (3) When the wire is so near with high temperature machines and materials and touched with oil for a long time, it can be short circuit and malfunction.
- (4) When doing terminal ports wiring, check the polarity.
- (5) In case that the high voltage line and the power line are wired at the same time, the induced interruption is caused. So it can be a reason for breakdown.

### 14.7.3 Example for wiring

- (1) Example for analog voltage output wiring (XBF-DV04C : Voltage)

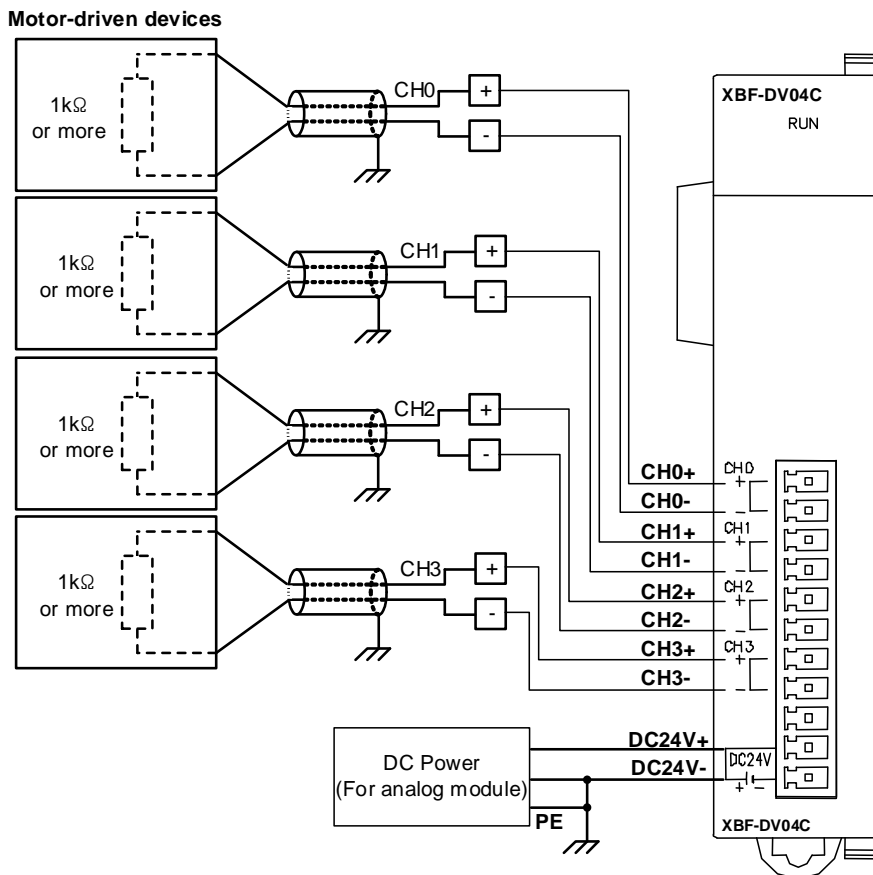

※1: Two-core twisted shield wire should be used as wire.

※2: DC power for analog power supply has to connect DC24V- with PE.

(2) Example for analog current output wiring (XBF-DC04C : Current)

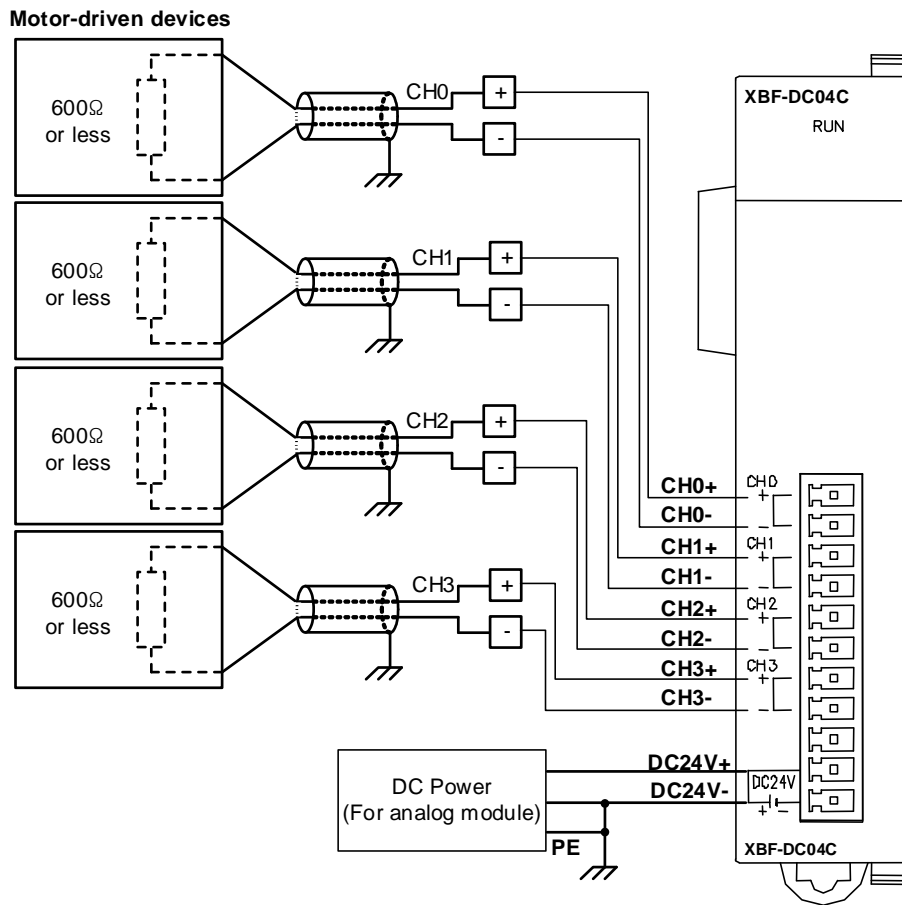

- ※ 1: Two-core twisted shield wire should be used as wire.
- ※ 2: DC power for analog power supply has to connect DC24V- with PE.

## 14.8 Operation Parameter Setting

A/D conversion module's operation parameters can be specified through XG5000's [I/O parameters].

### (1) Settings

For the user's convenience of D/A conversion module, XG5000 provides GUI (Graphical User Interface) for parameters setting of D/A conversion module. Setting items available through [I/O parameters] on the XG5000 project window are as described below in the table.

Item	Details
[I/O parameter]	<p>(1) Specify the following setting items necessary for the module operation.</p> <ul style="list-style-type: none"> <li>- Channel Enable/Disable setting</li> <li>- Output voltage(current) range</li> <li>- Input data format setting</li> <li>- Channel output status setting</li> <li>- Interpolation method setting</li> <li>- Interpolation time</li> </ul> <p>(2) When the parameters set by user in XG5000 is downloaded, that data is saved in flash memory of XGB basic unit.</p>

### 2) [I/O Parameter] Using method

- (1) Run XG5000 to create a project.  
(Refer to XG5000 program manual for details on how to create the project)
- (2) Double-click [I/O parameters] on the project window.

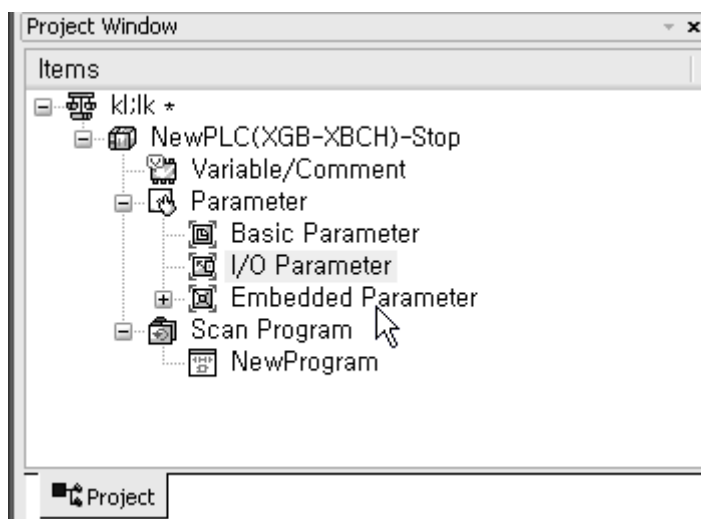

(3) [I/O Parameter setting] On the 'I/O parameters setting' screen, find and click the slot equipped with analog input module.

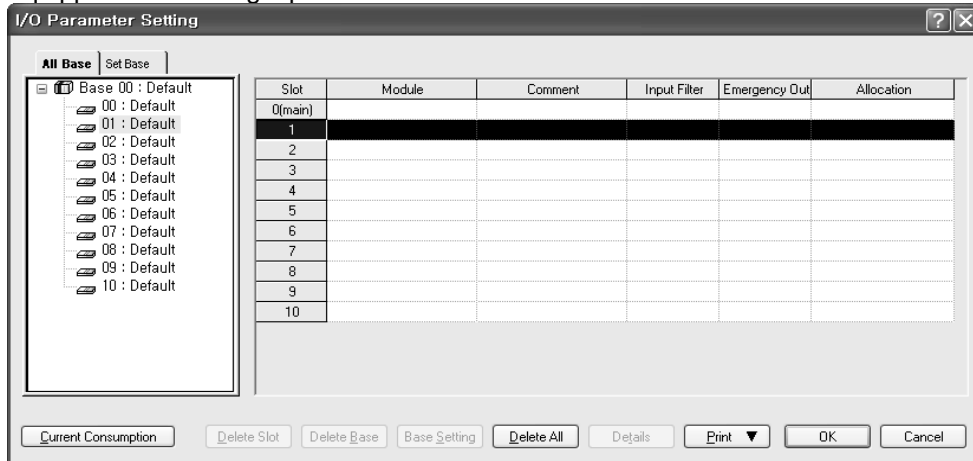

(4) Click the arrow button on the screen above to display the screen where an applicable module can be selected. Search for the applicable module to select.

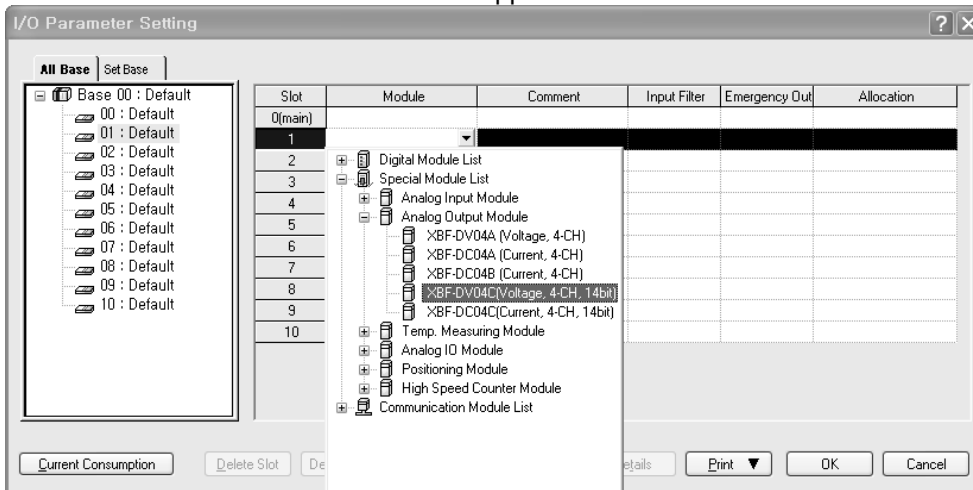

(5) After the module selected, click [Details].

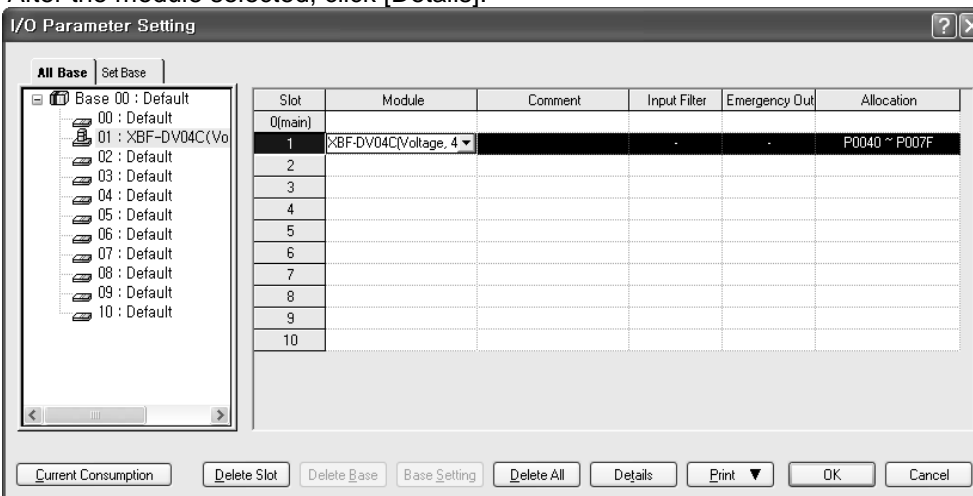

- (6) A screen will be displayed for you to specify parameters for respective channels as below. Click a desired item to display parameters to set for respective items.

XBF-DV04C(Voltage, 4-CH, 14bit) ? X

XBF-DV04C(Voltage, 4-CH, 14bit)

Parameter	CH0	CH1	CH2	CH3
<input type="checkbox"/> Channel status	Disable	Disable	Disable	Disable
<input type="checkbox"/> Output range	1~5V	1~5V	1~5V	1~5V
Input type	0~16000	0~16000	0~16000	0~16000
<input type="checkbox"/> Ch.Output type	Formal value	Formal value	Formal value	Formal value
<input type="checkbox"/> Interpolation method	Disable	Disable	Disable	Disable
Interpolation period	10[ms]	10[ms]	10[ms]	10[ms]

OK Cancel

## 14.9 Special Module Monitoring Functions

You can start to test the analog output module connecting by [Online] → [Connect] and then click [Monitor] → [Special Module Monitoring] menu in XG5000.

### 14.9.1 How to use special module monitoring

Special module monitoring function is described below based on the analog voltage output module (XGF-DV04C).

1) Start of [Special Module Monitoring]

Go through [Online] → [Connect] and [Monitor] → [Special module Monitoring] to start. If the status is not online, [Special Module Monitoring] menu will not be activated.

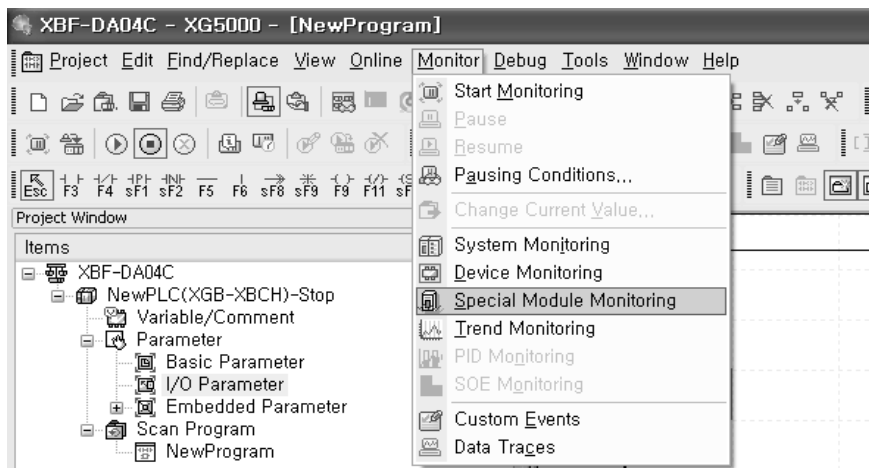

**Notes**

- 1) The screen may not normally be shown due to the lack of system resource. In this case, terminate all applications and try to start XG5000 again.
- 2) I/O parameter set in status of [Special Module Monitor] is temporarily set to implement the test. So, If status of [Special Module Monitor] is ended, I/O parameter which is set becomes extinct.
- 3) The test of [Special Module Monitor] is an examination function to check operation of the analog input module when the sequence program is not made up.

2) How to use [Special Module Monitoring]

- (1) Connecting XG5000 with PLC basic unit, [Special Module List] window will show base/slot information and types of special module by click [Monitor] → [Special Module Monitoring]. Special Module List will display the modules that are installed in PLC now.

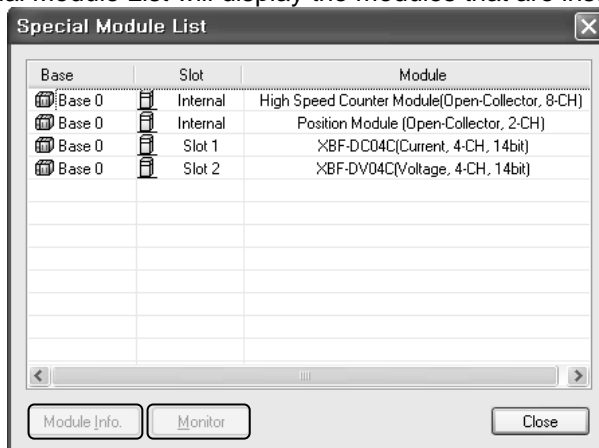

- (2) Select a special module then click [Module Info.] button to display the information as described below.

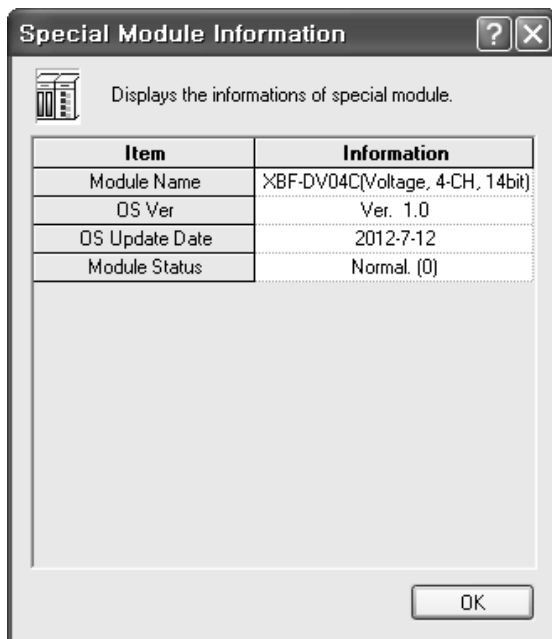

- (3) Click [Monitor] button in the [Special Module List] window to display the [Special Module Monitor] window as below.

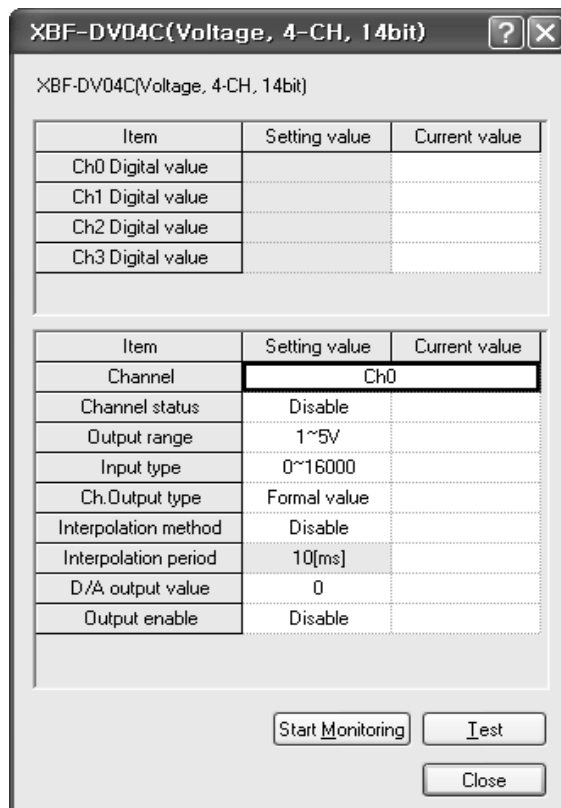

(4) [Start Monitoring] button will show you digital input data of the operating channel.

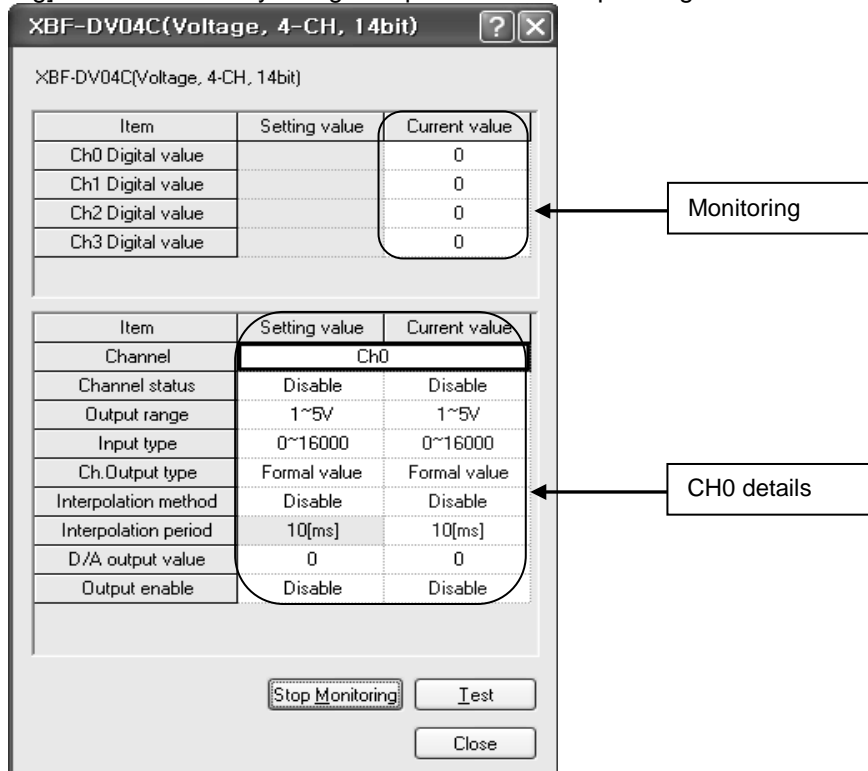

Execution screen of [Start Monitoring]

(5) [Test] is used to change the parameters of the voltage output module. You can change the parameters when you click the values at the bottom of the screen. It is only available when XGB CPU unit's status is in [Stop Monitoring].

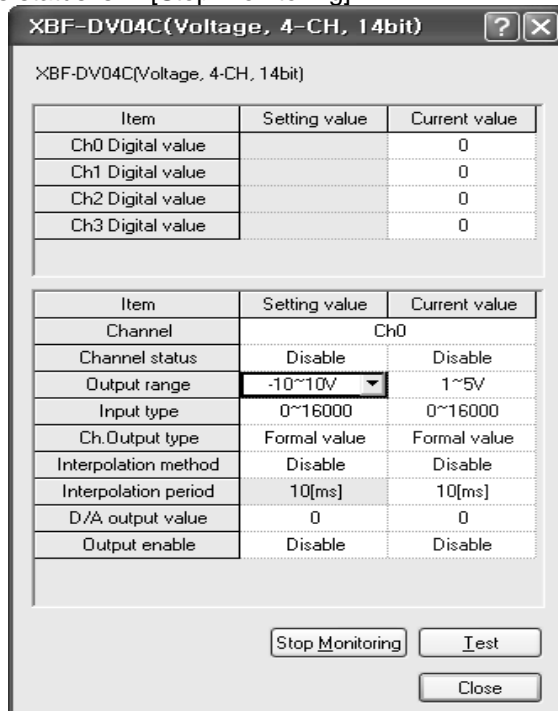

Execution screen of [Test]

(6) [Close] is used to escape from the monitoring/test screen. The Max value, Min value, current value will not saved anymore after the monitoring/test screen is closed.



## 14.10 Register U Devices

Register the variables for each module referring to the special module information that is set in the I/O parameter. The user can modify the variables and comments.

### 1) Procedure

(1) Select the special module type in the [I/O Parameter Setting] window.

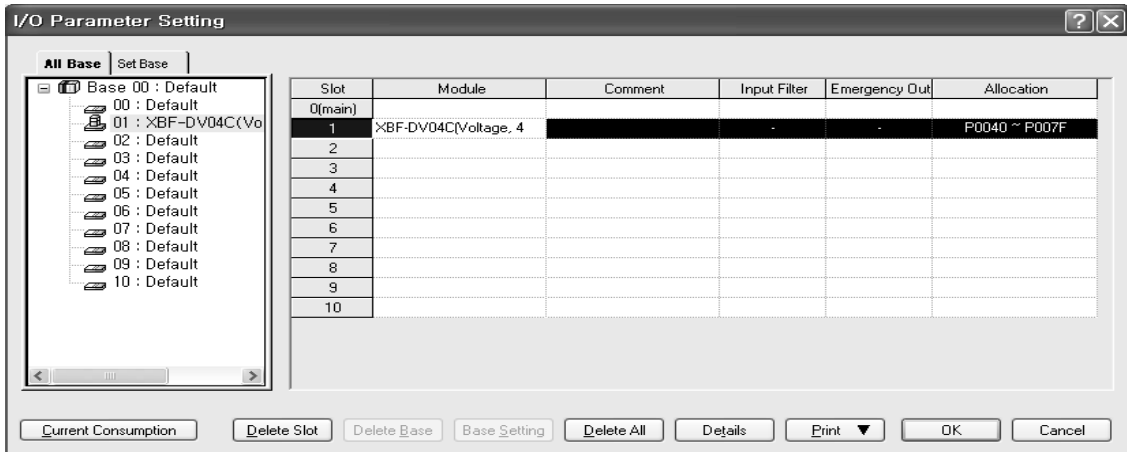

(2) Double click 'Variable/Comment' from the project window.

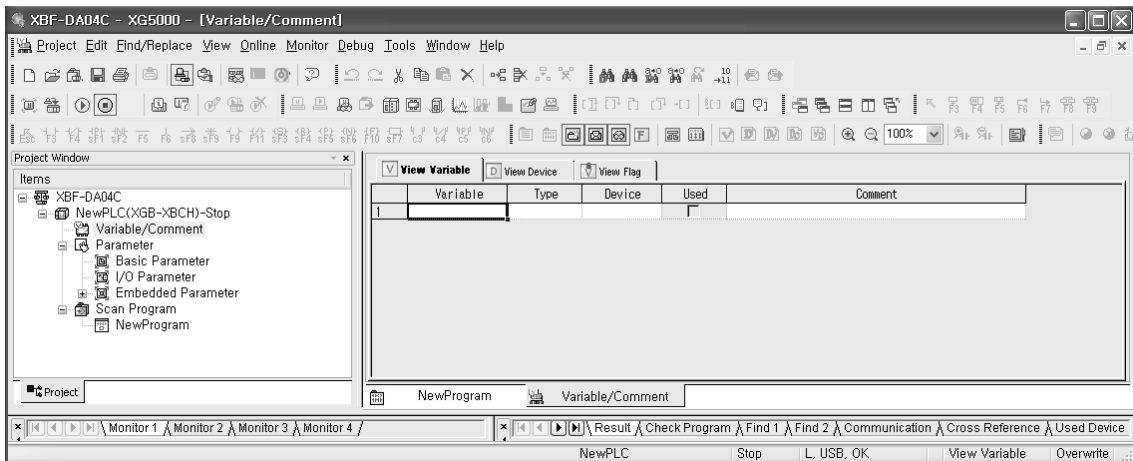

(3) Select [Edit] – [Register U Device].

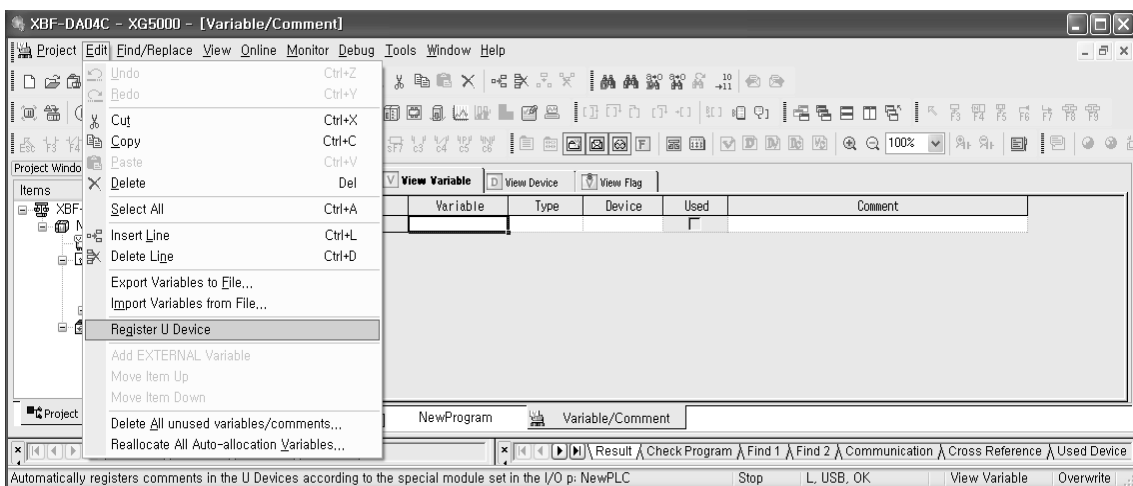

(4) Click 'Yes'

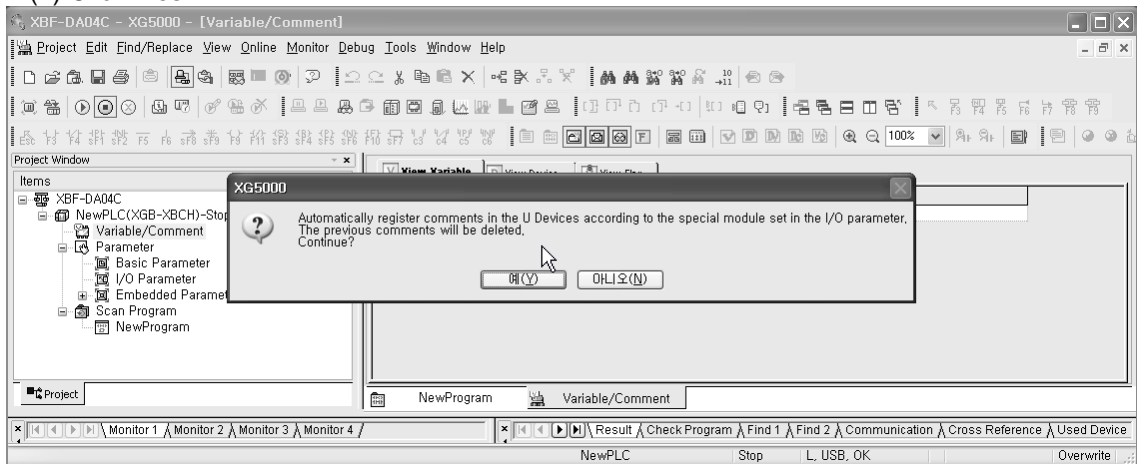

(5) As shown below, the variables are registered.

Variable	Type	Device	Used	Comment
1	_01_CH0_ERR	BIT	U01.00.0	Analog Output Module: CH0 Error
2	_01_CH1_ERR	BIT	U01.00.1	Analog Output Module: CH1 Error
3	_01_CH2_ERR	BIT	U01.00.2	Analog Output Module: CH2 Error
4	_01_CH3_ERR	BIT	U01.00.3	Analog Output Module: CH3 Error
5	_01_RDY	BIT	U01.00.F	Analog Output Module: Module Ready
6	_01_CH0_ACT	BIT	U01.01.0	Analog Output Module: CH0 Active
7	_01_CH1_ACT	BIT	U01.01.1	Analog Output Module: CH1 Active
8	_01_CH2_ACT	BIT	U01.01.2	Analog Output Module: CH2 Active
9	_01_CH3_ACT	BIT	U01.01.3	Analog Output Module: CH3 Active
10	_01_CH0_INTP	BIT	U01.01.8	Analog Output Module: CH0 Interpolation Enabled
11	_01_CH1_INTP	BIT	U01.01.9	Analog Output Module: CH1 Interpolation Enabled
12	_01_CH2_INTP	BIT	U01.01.A	Analog Output Module: CH2 Interpolation Enabled
13	_01_CH3_INTP	BIT	U01.01.B	Analog Output Module: CH3 Interpolation Enabled
14	_01_CH0_OUTEN	BIT	U01.02.0	Analog Output Module: CH0 Output Status Setting
15	_01_CH1_OUTEN	BIT	U01.02.1	Analog Output Module: CH1 Output Status Setting
16	_01_CH2_OUTEN	BIT	U01.02.2	Analog Output Module: CH2 Output Status Setting
17	_01_CH3_OUTEN	BIT	U01.02.3	Analog Output Module: CH3 Output Status Setting
18	_01_OUTEN	WORD	U01.02	Analog Output Module: Output Status Setting
19	_01_CH0_DATA	WORD	U01.03	Analog Output Module: CH0 Input
20	_01_CH1_DATA	WORD	U01.04	Analog Output Module: CH1 Input
21	_01_CH2_DATA	WORD	U01.05	Analog Output Module: CH2 Input
22	_01_CH3_DATA	WORD	U01.06	Analog Output Module: CH3 Input

(6) For IEC type, as shown below, the variables are registered.

Variable Kind	Variable	Type	Address	Initial Value	Retain	Used	EIP	Comment
1	VAR_GLOBAL _01_CH0_ACT	BOOL	XU0.1.16					Analog Output Module: CH0 Active
2	VAR_GLOBAL _01_CH0_DATA	WORD	XU0.1.3					Analog Output Module: CH0 Input
3	VAR_GLOBAL _01_CH0_ERR	BOOL	XU0.1.0					Analog Output Module: CH0 Error
4	VAR_GLOBAL _01_CH0_INTP	BOOL	XU0.1.24					Analog Output Module: CH0 Interpolation Enabled
5	VAR_GLOBAL _01_CH0_OUTEN	BOOL	XU0.1.32					Analog Output Module: CH0 Output Status Setting
6	VAR_GLOBAL _01_CH1_ACT	BOOL	XU0.1.17					Analog Output Module: CH1 Active
7	VAR_GLOBAL _01_CH1_DATA	WORD	XU0.1.4					Analog Output Module: CH1 Input
8	VAR_GLOBAL _01_CH1_ERR	BOOL	XU0.1.1					Analog Output Module: CH1 Error
9	VAR_GLOBAL _01_CH1_INTP	BOOL	XU0.1.25					Analog Output Module: CH1 Interpolation Enabled
10	VAR_GLOBAL _01_CH1_OUTEN	BOOL	XU0.1.33					Analog Output Module: CH1 Output Status Setting
11	VAR_GLOBAL _01_CH2_ACT	BOOL	XU0.1.18					Analog Output Module: CH2 Active
12	VAR_GLOBAL _01_CH2_DATA	WORD	XU0.1.5					Analog Output Module: CH2 Input
13	VAR_GLOBAL _01_CH2_ERR	BOOL	XU0.1.2					Analog Output Module: CH2 Error
14	VAR_GLOBAL _01_CH2_INTP	BOOL	XU0.1.26					Analog Output Module: CH2 Interpolation Enabled
15	VAR_GLOBAL _01_CH2_OUTEN	BOOL	XU0.1.34					Analog Output Module: CH2 Output Status Setting
16	VAR_GLOBAL _01_CH3_ACT	BOOL	XU0.1.19					Analog Output Module: CH3 Active
17	VAR_GLOBAL _01_CH3_DATA	WORD	XU0.1.6					Analog Output Module: CH3 Input
18	VAR_GLOBAL _01_CH3_ERR	BOOL	XU0.1.3					Analog Output Module: CH3 Error
19	VAR_GLOBAL _01_CH3_INTP	BOOL	XU0.1.27					Analog Output Module: CH3 Interpolation Enabled
20	VAR_GLOBAL _01_CH3_OUTEN	BOOL	XU0.1.35					Analog Output Module: CH3 Output Status Setting
21	VAR_GLOBAL _01_OUTEN	WORD	XU0.1.2					Analog Output Module: Output Status Setting
22	VAR_GLOBAL _01_RDY	BOOL	XU0.1.15					Analog Output Module: Module Ready
23								

2) Save variables

- (1) The contents of 'View Variable' can be saved as a text file.
- (2) Select [Edit] -> [Export to File].
- (3) The contents of 'View variable' are saved as a text file.

3) View variables

- (1) The example of XBC type is as follows.

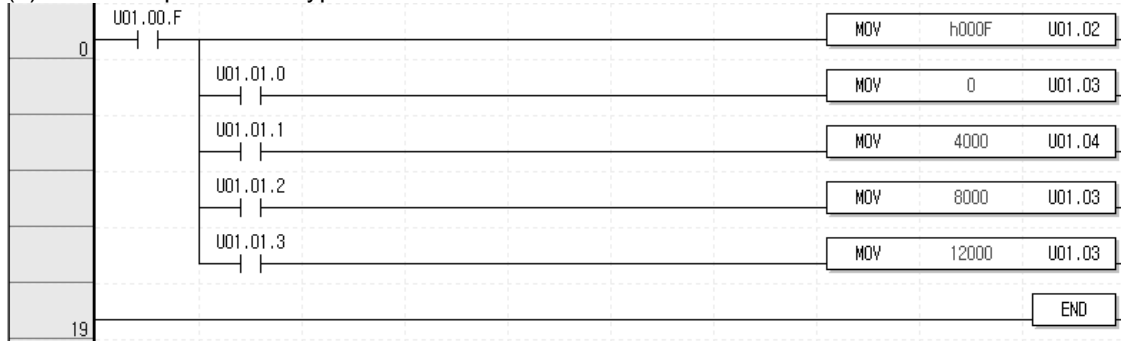

- (2) Select [View] -> [Variables]. The devices are changed into variables.

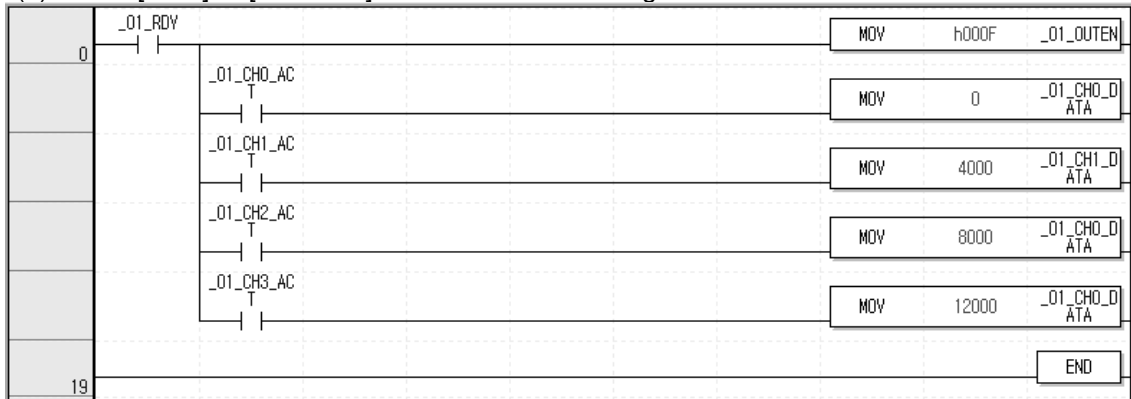

- (3) Select [View] -> [Devices/Variables]. Devices and variables are both displayed.

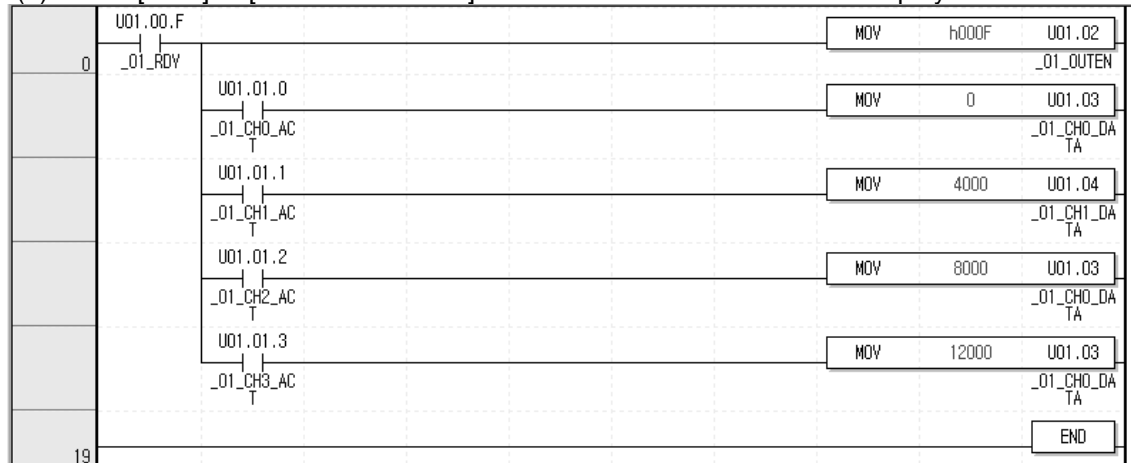

(4) Select [View] -> [Device/Comments]. Devices and comments are both displayed

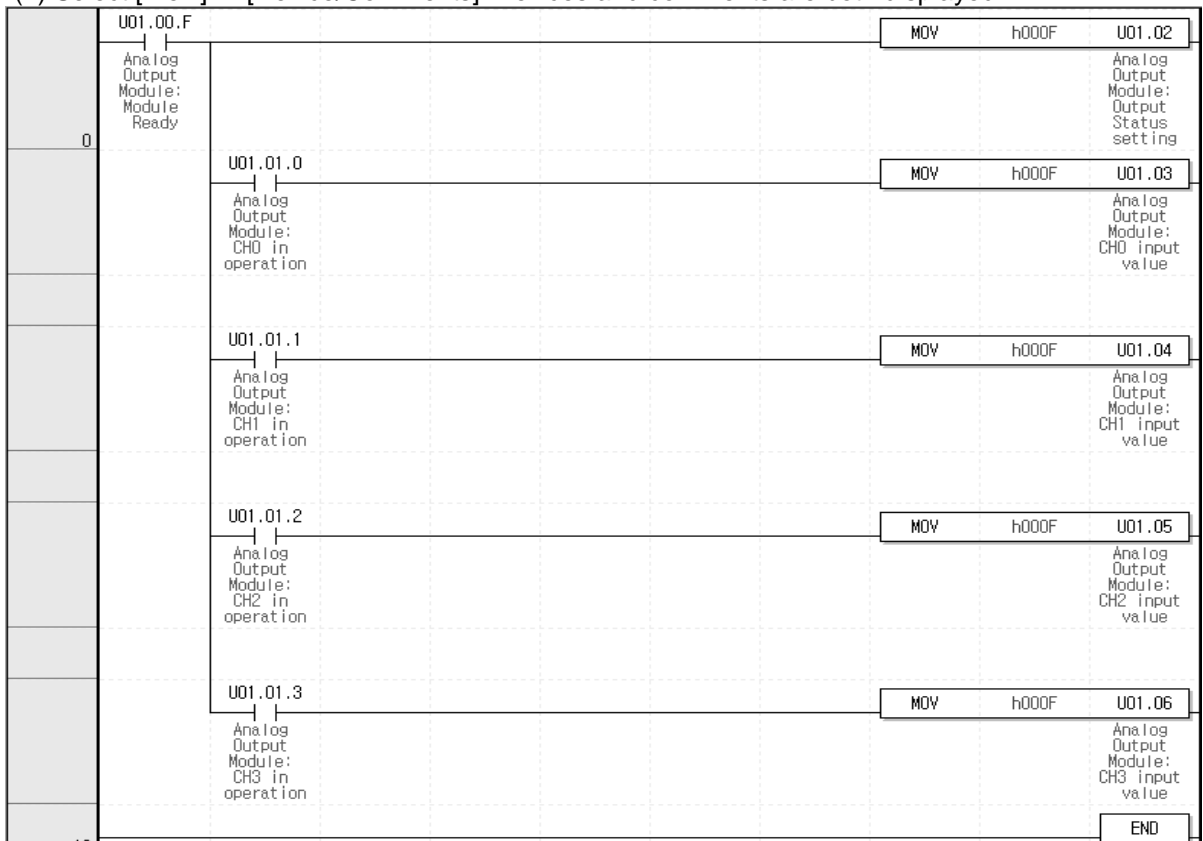

(5) In case of IEC-type can also see variety option variables like (1) ~ (4). As shown below, there is an example when 'Variable/Instruction window' is selected in the IEC-type.

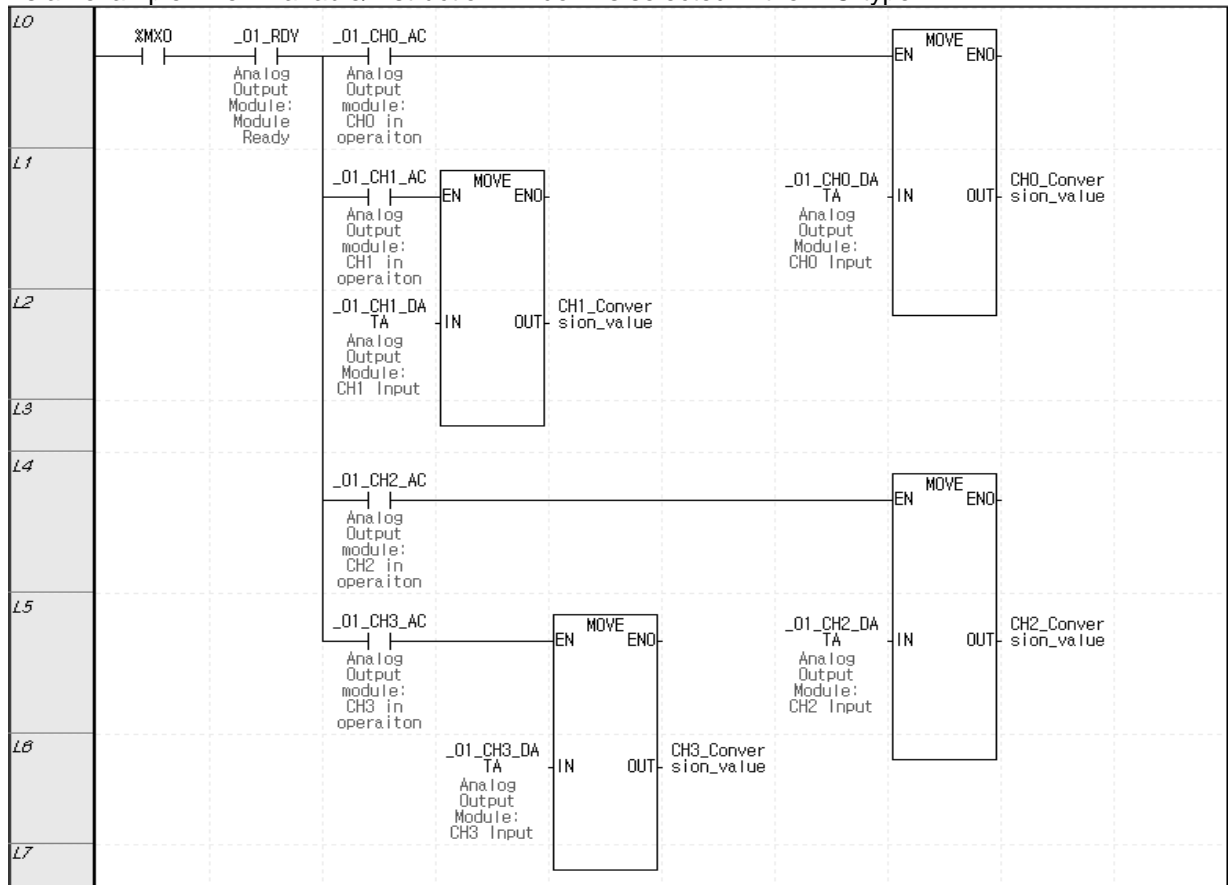

## 14.11 Internal Memory

Describes configuration and function of internal memory

### 14.11.1 Data I/O area

Describes data I/O area of analog output module.

Device assigned		Type	Description	Details	R/W	Direction of signal
XBM/XBC	XEC					
U0y.00.0	%UX0.y.0	BIT	Channel0 Error	Parameter setting On(1): Setting error Off(0): Setting normal	R	DV04C / DC04C → CPU
U0y.00.1	%UX0.y.1	BIT	Channel1 Error			
U0y.00.2	%UX0.y.2	BIT	Channel2 Error			
U0y.00.3	%UX0.y.3	BIT	Channel3 Error			
U0y.00.F	%UX0.y.15	BIT	Module Ready	On(1): Ready for action Off(0): Not ready		
U0y.01.0	%UX0.y.16	BIT	Channel0 In operation	Channel operation On(1): Operation Off(0): Stop	R	DV04C / DC04C → CPU
U0y.01.1	%UX0.y.17	BIT	Channel1 In operation			
U0y.01.2	%UX0.y.18	BIT	Channel2 In operation			
U0y.01.3	%UX0.y.19	BIT	Channel3 In operation			
U0y.01.8	%UX0.y.24	BIT	Channel 0 Interpolation output	Interpolation output status On(1): Interpolation output Off(0): Stop	R	DV04C / DC04C → CPU
U0y.01.9	%UX0.y.25	BIT	Channel 1 Interpolation output			
U0y.01.A	%UX0.y.26	BIT	Channel 2 Interpolation output			
U0y.01.B	%UX0.y.27	BIT	Channel 3 Interpolation output			
U0y.01.C	%UX0.y.28	BIT	Channel0 disconnection detection	Disconnection detection On(1): Disconnection detection Off(0): Stop (Only for XBF-DC04C)	R	DC04C → CPU
U0y.01.D	%UX0.y.29	BIT	Channel1 disconnection detection			
U0y.01.E	%UX0.y.30	BIT	Channel2 disconnection detection			
U0y.01.F	%UX0.y.31	BIT	Channel3 disconnection detection			
U0y.02	%UW0.y.2	WORD	Output enable setting	Output status setting	W	DV04C / DC04C ↔ CPU
U0y.02.0	%UX0.y.32	BIT	Channel0 Output enable setting	Output enable setting On(1): Output enable Off(0): Output prohibition	W	DV04C / DC04C ↔ CPU
U0y.02.1	%UX0.y.33	BIT	Channel1 Output enable setting			
U0y.02.2	%UX0.y.34	BIT	Channel Output enable setting			
U0y.02.3	%UX0.y.35	BIT	Channel3 Output enable setting			
U0y.03	%UW0.y.3	WORD	Channel0 Input value	Output conversion value	W	DV04C / DC04C ↔ CPU
U0y.04	%UW0.y.4	WORD	Channel1 Input value		W	DV04C / DC04C ↔ CPU
U0y.05	%UW0.y.5	WORD	Channel2 Input value		W	DV04C / DC04C ↔ CPU
U0y.06	%UW0.y.6	WORD	Channel3 Input value		W	DV04C/ DC04C↔ CPU

- In the device assigned, 'y' means slot number equipped with module.
- In order to read 'CH2 conversion value' of A/D conversion module installed on Slot No.4, it shall be displayed as U04.05. (In case of IEC type %UW0.4.5)



- In order to read 'CH1 conversion value' of A/D conversion module installed on Slot No.5, it shall be displayed as U05.02.1 (In case of IEC type %UX0.5.33)

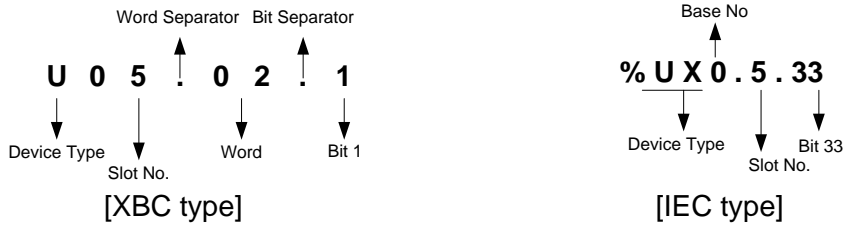

- 1) Module Ready/Error flag ( '(' ) means the case of IEC type, y: slot number)
    - (1) U0y.00.F(%UX0.y.15): It will be ON when PLC CPU is powered or reset with D/A conversion ready to process A/D conversion.
    - (2) U0y.00.0 ~ U0y.00.3(%UX0.y.0 ~ %UX0.y.3): It is a flag to display the error status of D/A conversion module.
- ※ The base number of XGB PLC is '0'.

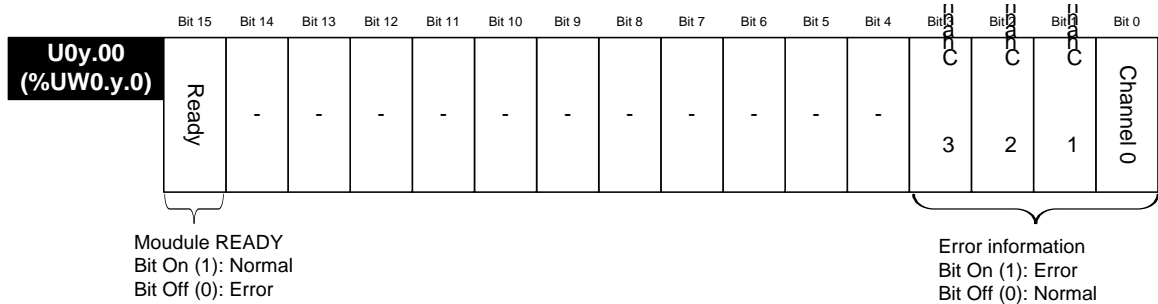

2) Channel operation information

(1) This area shows the channel being used.

※ The base number of XGB PLC is '0'.

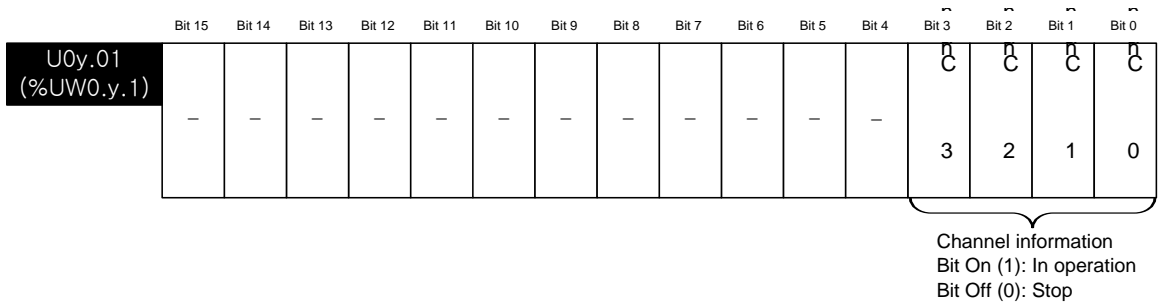

3) Status of interpolation output

(1) This area shows the channel being outputting interpolation.

※ The base number of XGB PLC is '0'.

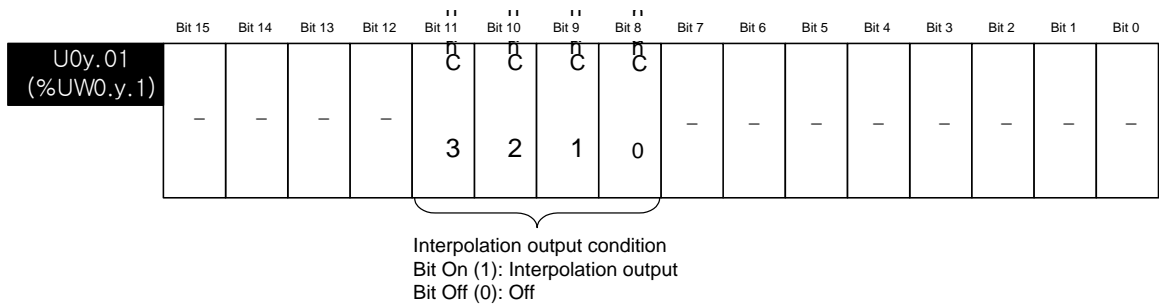

4) Output disconnection detection (Only for current output module XBF-DC04C)

(1) This area shows the channel detecting output disconnection.

※ The base number of XGB PLC is '0'.

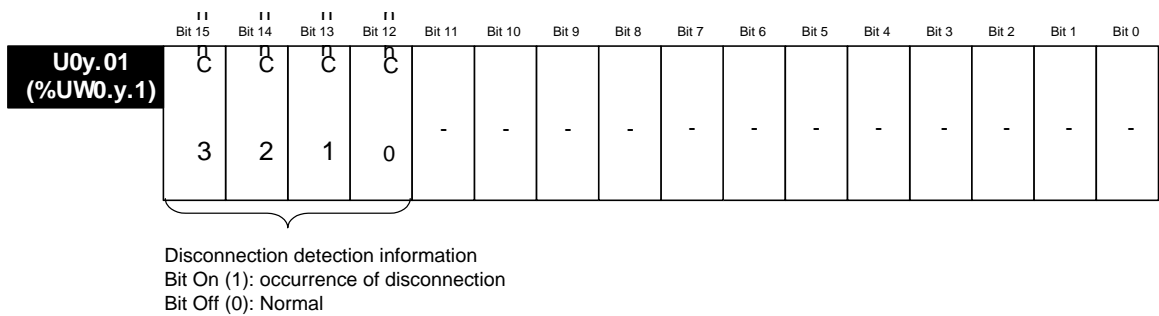

5) Output permission setting

- (1) The output enable / disable for each channel can be set.
  - (2) When the output permission is not set, the output of all channels will be prohibited.
- ※ The base number of XGB PLC is '0'.

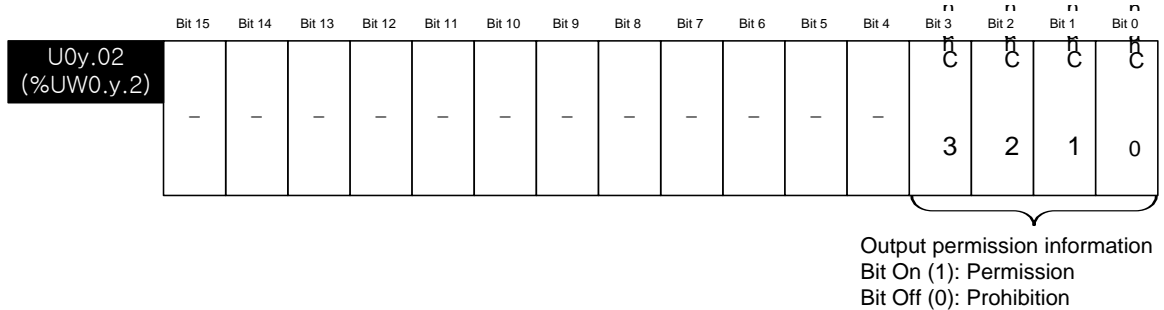

6) Digital input value

- (1) Unsigned value(-192~16,191 / 0~16,191), Signed value(-8,192~8,191 / -8,000~8,191), Precise value(-952~5,047 / -60~5,059 / -120~10,119 / -10,240~10,239 / 3,808~20,191 / 0~20,239), Percentile value(-120~10,119 / 0~10,119) can be used within these ranges depending on the setting of input data type.
  - (2) If the digital input value is not set, it will be handled as '0'.
- ※ The base number of XGB PLC is '0'.

	Bit 15	Bit 14	Bit 13	Bit 12	Bit 11	Bit 10	Bit 9	Bit 8	Bit 7	Bit 6	Bit 5	Bit 4	Bit 3	Bit 2	Bit 1	Bit 0
U0y.03 (%UW0.y.3)	Channel 0 Digital input data															
U0y.04 (%UW0.y.4)	Channel 1 Digital input data															
U0y.05 (%UW0.x.5)	Channel 2 Digital input data															
U0y.06 (%UW0.y.6)	Channel 3 Digital input data															

**Notes**

(1) If the external 24V is not supplied, the operation channel information [U0y.01.0 ~ U0y.01.3, (%UX0.y.16 ~ %UX0.y.19)], interpolation output status flag [U0y.01.8 ~ U0y.01.B (%UX0.y.24 ~ %UX0.y.27)], output disconnection detection flag [U0y.01.C ~ U0y.01.F (%UX0.y.28 ~ %UX0.y.31) ], will be turned off.



## 14.11.2 Operation parameters setting area

Setting area of D/A conversion module's Run parameters is as described in Table.

Memory address	Descriptions	Details	R/W	Remark	
0	Specify channel to use	Bit 0 ~ Bit 3 0: Stop, 1: Operation	R/W	PUT/GET	
1	Specify voltage output range	Output range setting (2Bit) 00 : 1 ~ 5 V (4 ~ 20mA) 01 : 0 ~ 5 V (0 ~ 20mA) 10 : 0 ~ 10 V 11 : -10 ~ 10V	R/W		
2	Specify input type	Input data type setting (2Bit) 00: 0 ~ 16,000 01: -8,000 ~ 8,000 10: Precise value 11: 0 ~ 10,000 - In case of precise value 4 ~ 20mA: 4,000 ~ 20,000 0 ~ 20mA: 0 ~ 20,000 1 ~ 5V: 1000 ~ 5,000 0 ~ 5V: 0 ~ 5,000 0 ~ 10V: 0 ~ 10,000 -10 ~ 10V: -10,000 ~ 10,000	R/W		
3	Specify Ch0 output setting	Output status setting (2Bit) 00: Previous value output 01: Min value output 10: Mid value output 11: Max value output	R/W		
4	Specify Ch1 output setting				
5	Specify Ch2 output setting				
6	Specify Ch3 output setting				
11	Interpolation method	Interpolation method setting (2Bit) 00: Prohibition 01: Linear interpolation 10: S-type interpolation	R/W		
12	Interpolation time	Interpolation time setting (2Bit) 00: 10[ms] 01: 100[ms] 10: 1[s] 11: 60[s]	R/W		
13	CH0 setting error	0: Normal operation 31#: Excess error of output range setting 41#: Excess error of digital input value range 51#: Excess error of interpolation method range (Decimal, #:Channel number, CH 0-3)	R		GET
14	CH1 setting error				
15	CH2 setting error				
16	CH3 setting error				
17	CH 0 interpolation value	When the interpolation operates: Show operated current output digital value. When the interpolation is prohibited: Show the output value in the data I/O area. (U0y.03~06, %UW0.y.3~6)	R	GET	
18	CH 1 interpolation value				
19	CH 2 interpolation value				
20	CH 3 interpolation value				
22 ~ 44	System area (Offset/Gain save area)	Read / Write Prohibited	-	-	

**Notes**

- (1) In case of U0y.00.0~U0y.00.3 and IEC type, %UX0.y.0~%UX0.y.3 turns on and operates as the basic setting value when Inputting except set value in 1, 2, 11 area of memory address.
- (2) The system area (after No. 22) is prohibited to read/write.  
If this area is changed, malfunctions or breakdowns will be happened.

1) Operation channel setting

If the operation channel is not set, all channels will be stopped.

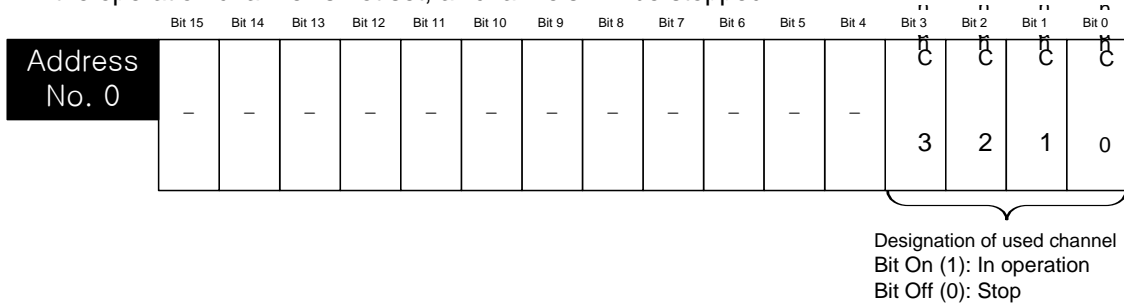

2) Output range setting

The range of analog output voltage is DC 0 ~ 10V. And the range of analog output current is DC 4 ~ 20mA, DC 0 ~ 20mA.

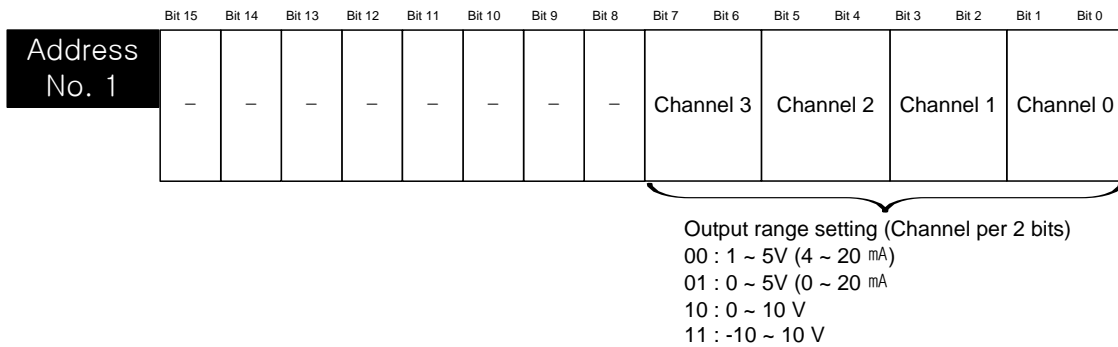

3) Input data type setting

- (1) Input data type can be set for each channel.
- (2) All channels will be handled as the range of 0~ 16,000 when the input data type is not set.

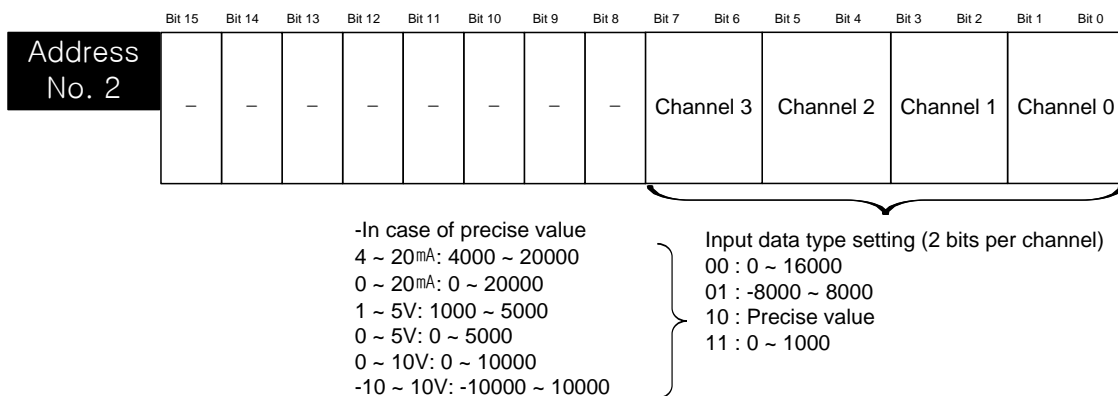

4) Output status setting

- (1) When the XGB basic unit is stopped, set the analog output status.
- (2) When the output status setting is not specified, output the previous value.

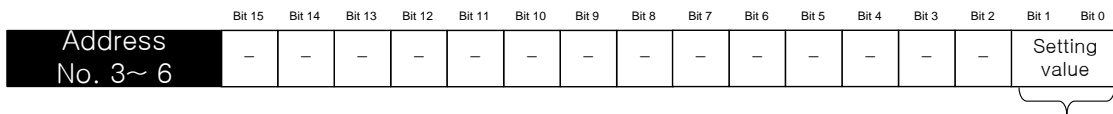

Set the output status ( 2 bits)  
 00 : Previous value output  
 01 : Min value output  
 10 : Mid value output  
 11 : Max value output

Address	Details	Setting
3	Channel 0 Output status setting	Input data type setting (bit) → 00: Previous value → 01: Min value → 10: Mid value → 11: Max value
4	Channel 1 Output status setting	
5	Channel 2 Output status setting	
6	Channel 3 Output status setting	

5) Interpolation method setting

Show the setting of the interpolation method of each channel.

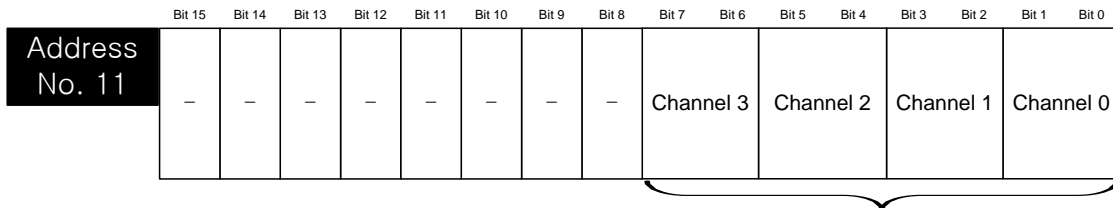

Interpolation method setting (2 bits per channel)  
 00 : Prohibition  
 01 : Direct interpolation  
 10 : S type interpolation

6) Interpolation time setting

Show the setting of interpolation time of each channel.

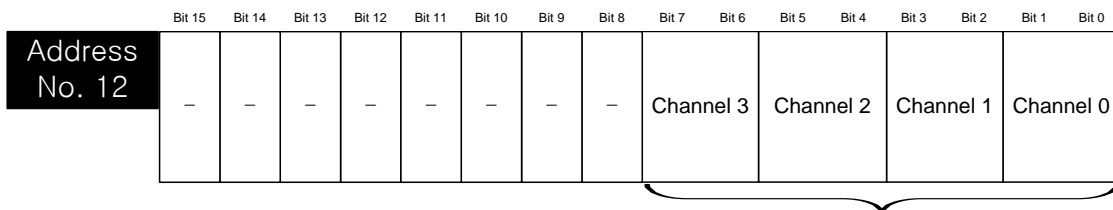

Interpolation time setting (2 bits per channel)  
 00 : 10[ms]  
 01 : 100[ms]  
 10 : 1[s]  
 11 : 60[s]

7) Channel error

Show the error code of each channel.

When two error or more are happened, the high priority of error code will be saved.

	Bit 15	Bit 14	Bit 13	Bit 12	Bit 11	Bit 10	Bit 9	Bit 8	Bit 7	Bit 6	Bit 5	Bit 4	Bit 3	Bit 2	Bit 1	Bit 0
Address No. 13	Channel 0 error code															
Address No. 14	Channel 1 error code															
Address No. 15	Channel 2 error code															
Address No. 16	Channel 3 error code															

Error code (Decimal)	Details	Error code order of priority	Remarks
0	Normal operation	—	#:CH number 0-3
31#	Excess error of output range setting	2	
41#	Excess error of digital input value range	1	
51#	Excess error of interpolation method range	3	

8) Interpolation operation value

Show the interpolation operation value of each channel.

	Bit 15	Bit 14	Bit 13	Bit 12	Bit 11	Bit 10	Bit 9	Bit 8	Bit 7	Bit 6	Bit 5	Bit 4	Bit 3	Bit 2	Bit 1	Bit 0
Address No. 17	Channel 0 Interpolation operation value															
Address No. 18	Channel 1 Interpolation operation value															
Address No. 19	Channel 2 Interpolation operation value															
Address No. 20	Channel 3 Interpolation operation value															

9) System area

The system area (after No. 22) is prohibited to read/write.

 <b>Warning</b>	If this area is changed, malfunctions or breakdowns will be happened. So do not control this area.
--	--

## 14.12 Example Program

### 14.12.1 Analog output program

(1) Program example using [I/O Parameter Setting].

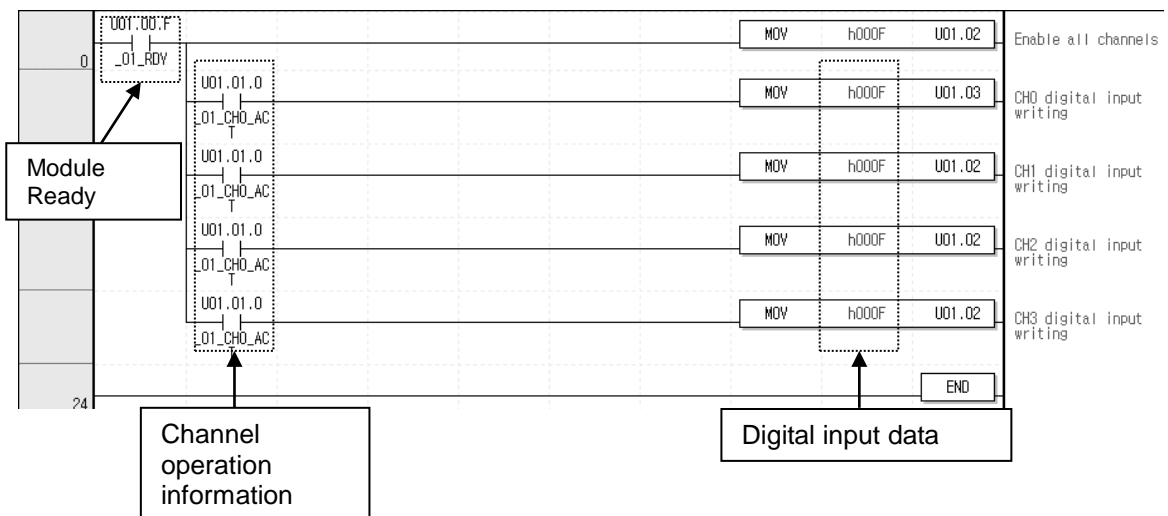
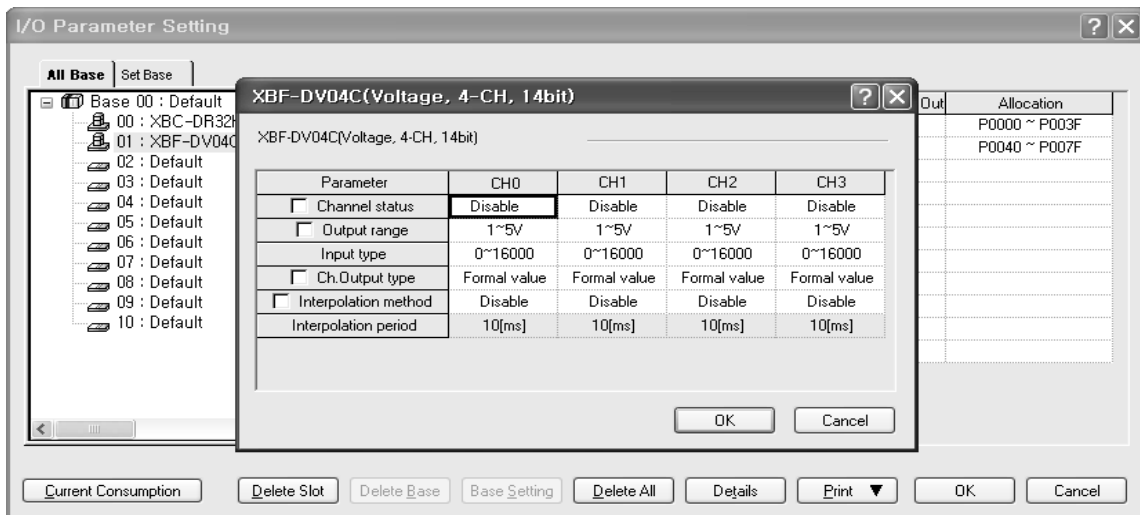
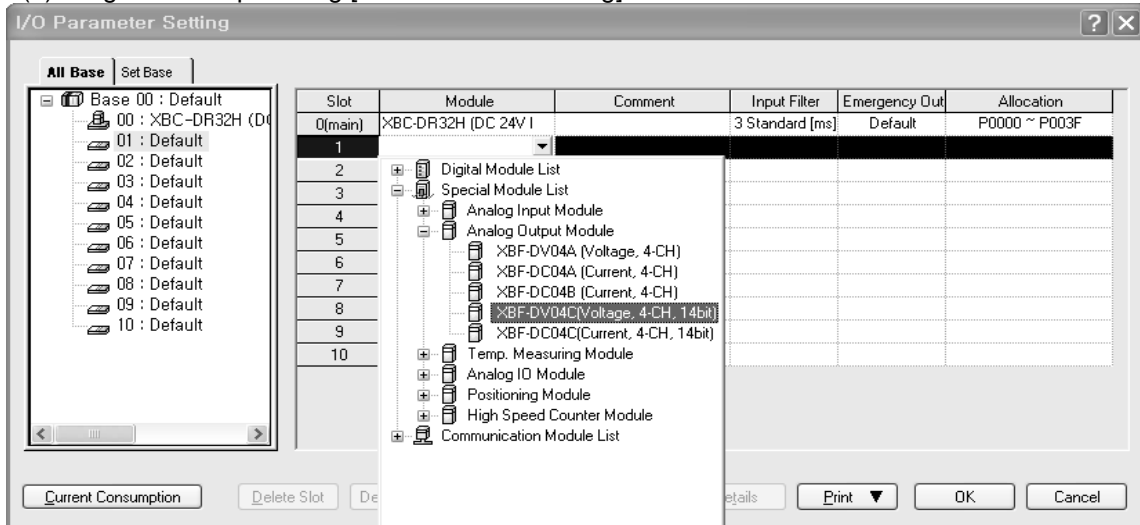

(2) Program example with PUT/GET instruction

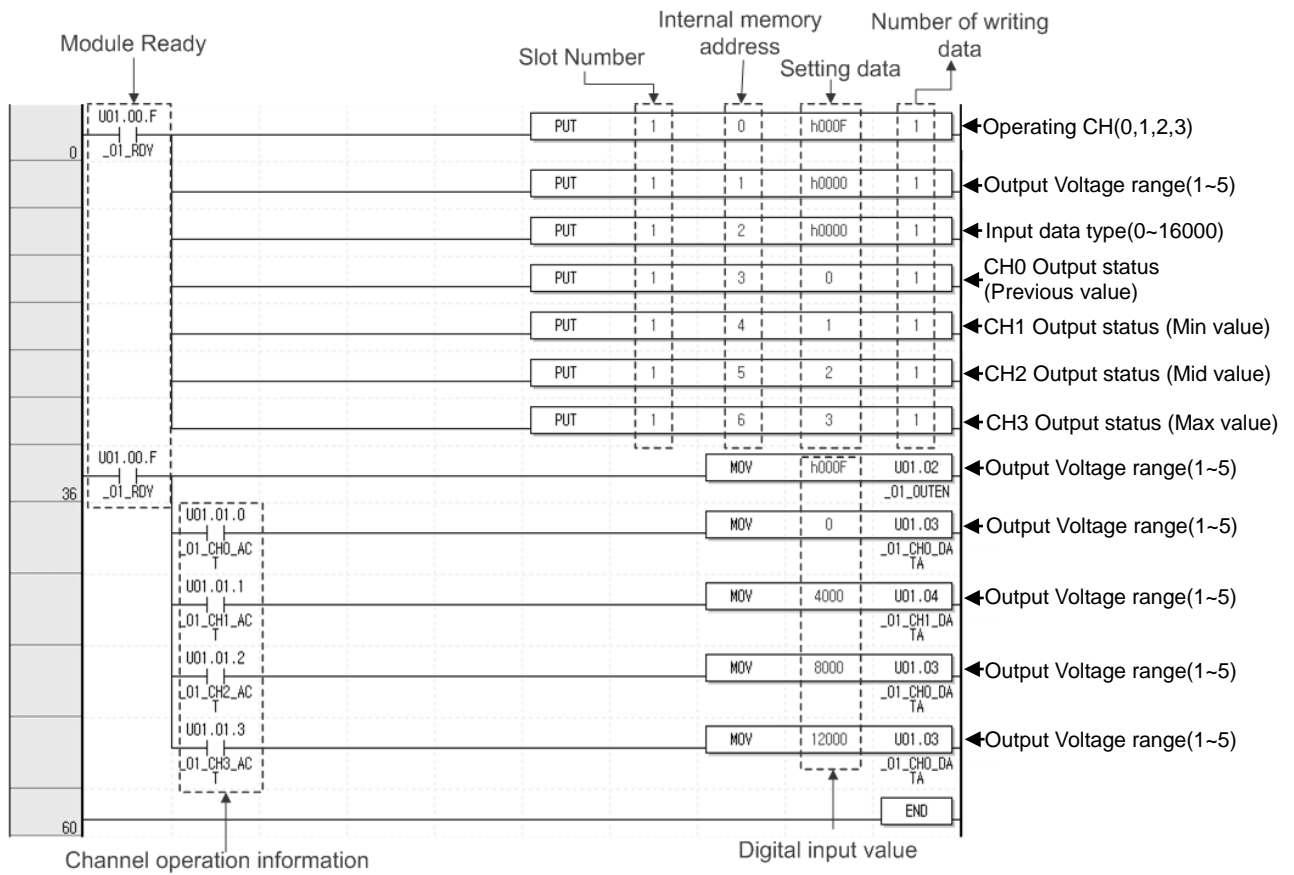

(3) Program example using parameter in case of IEC type

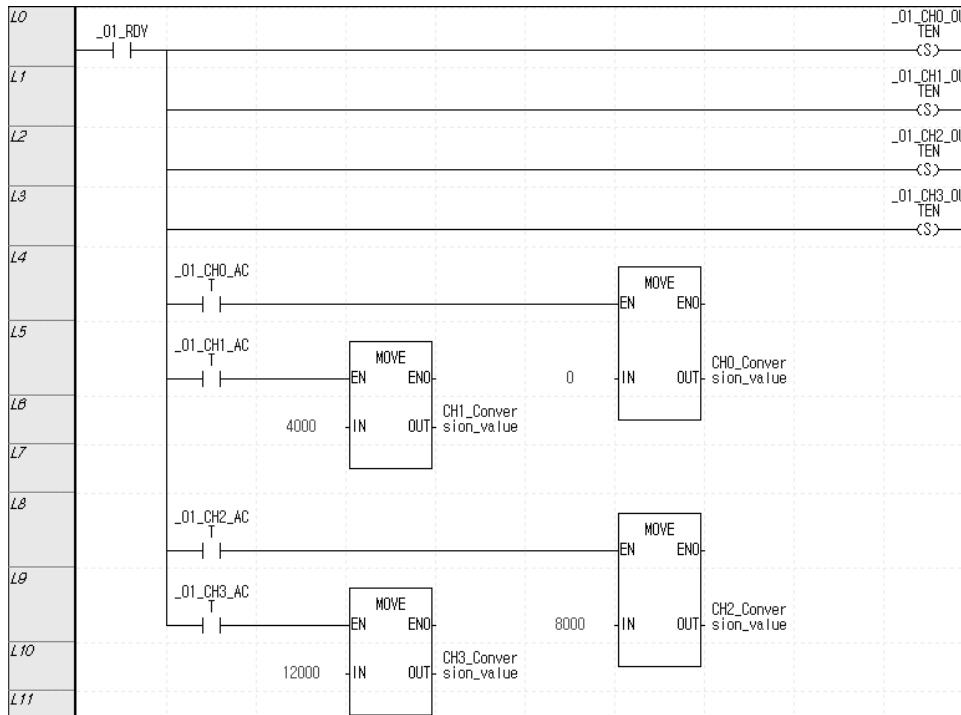

(4) Program example using PUT/GET instruction in case of IEC type

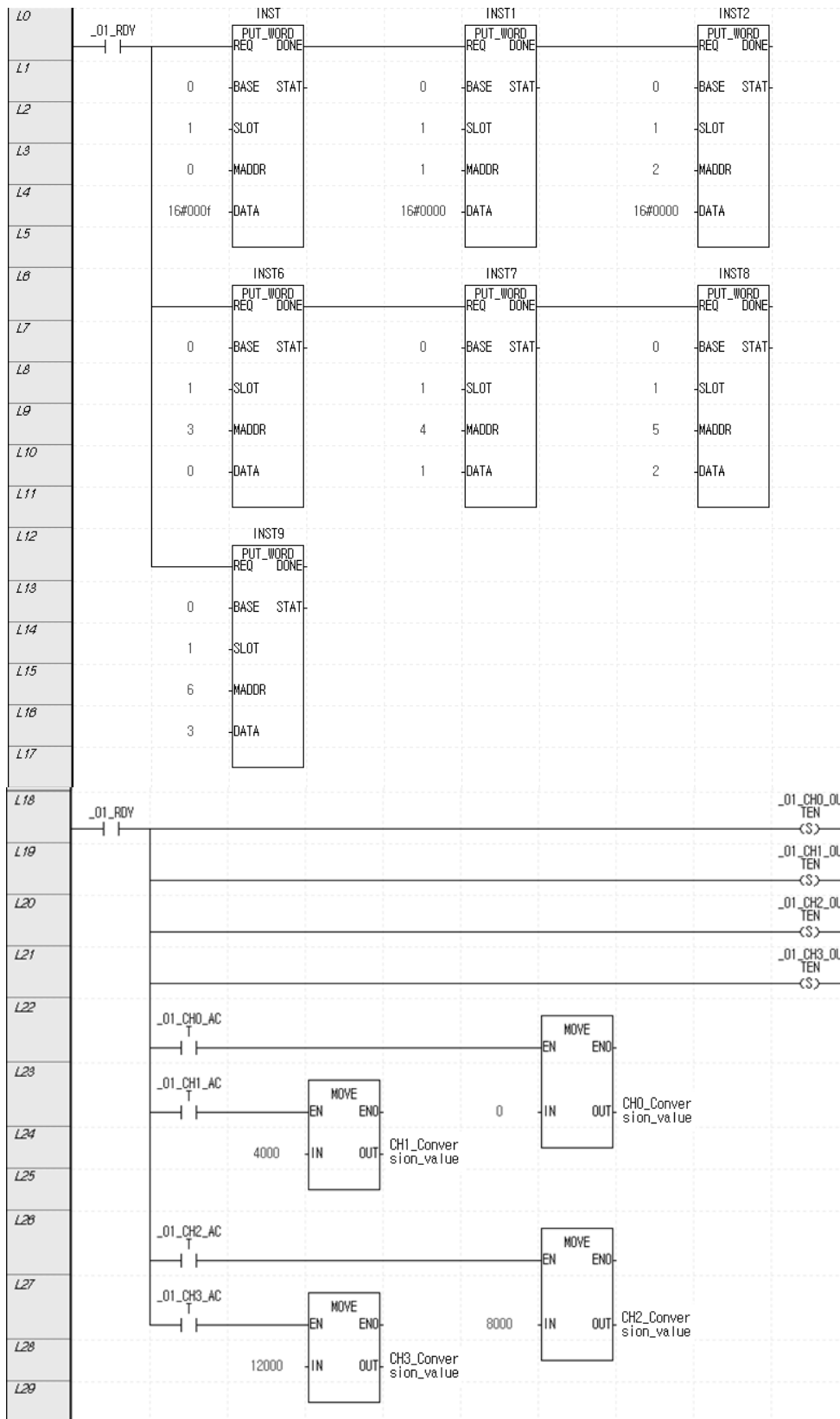

## 14.13 Breakdown Test

Explain the test and measure method of breakdown while using the analog input module.

### 14.13.1 Checking the LED status in case of error

The analog input module has a LED and is able to check whether there is error of the module through the sign of LED.

Item	Normal Status	When CH is disconnected	When parameter setting is error
LED	Light on	Flickering 1s intervals	Flickering 1s intervals (When the output parameter setting is error)
Module Operation	Normal operation Operation of all functions	Operation of all functions	Operation of all functions (Operation by basic value of parameter)
Measure	–	Check output wiring	Check parameter setting

### 14.13.2 Check the module status

The status of analog input module (Module type/information/OS version) can be checked through the system monitor of XG5000.

#### 1) The order of execution

It can be implemented through one of the methods among next items.

- (1)[Monitor] -> [System Monitor] -> Click the right button of mouse on the painting of module.  
-> [Module Information]
- (2)[Monitor] -> [System Monitor] -> Double click the painting of module
- (3)[Monitor] -> [Special Module Monitor] -> [XBF-AD04C] Selection ->Click the module information
- (4)[Online] -> [I/O Information] -> [XBF-AD04C] Selection -> Click the details
- (5)[Online] -> [I/O Information] -> [XBF-AD04C] Double click

#### 2) Module information

- (1) Module Name: Information of recently equipped module device is shown.
- (2) OS Version: OS version of module is shown.
- (3) OS Update Date: The OS prepared date of module is shown.
- (4) Module status: The present error code is shown.



14.13.3 Check and Measure the breakdown

(1) RUN LED is turned off.

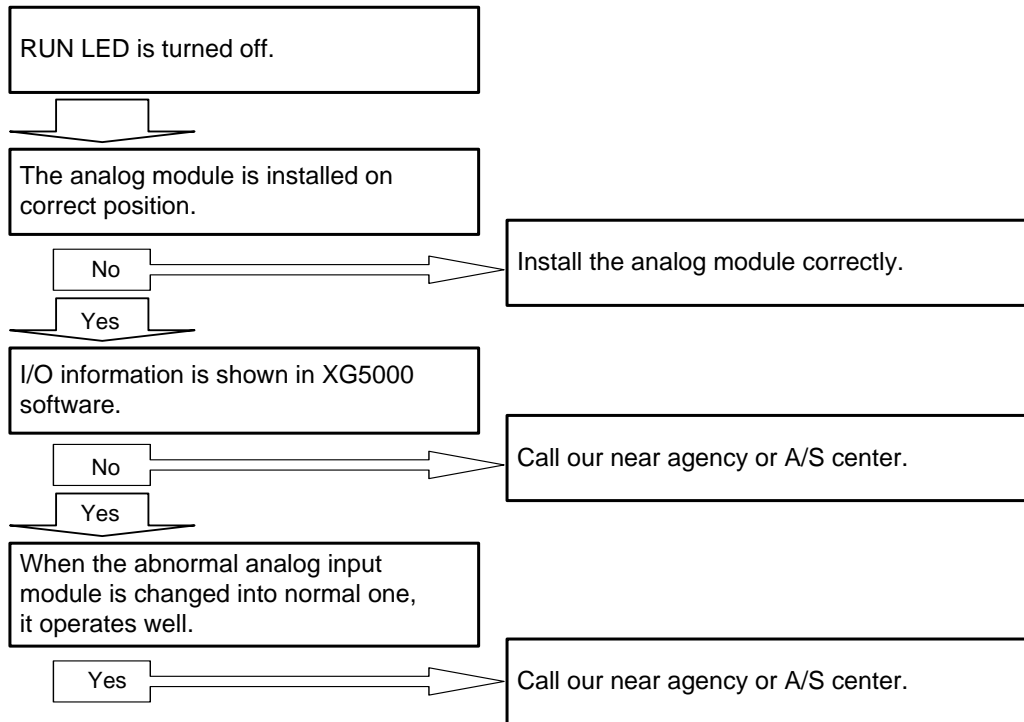

(2) RUN LED is flickering.

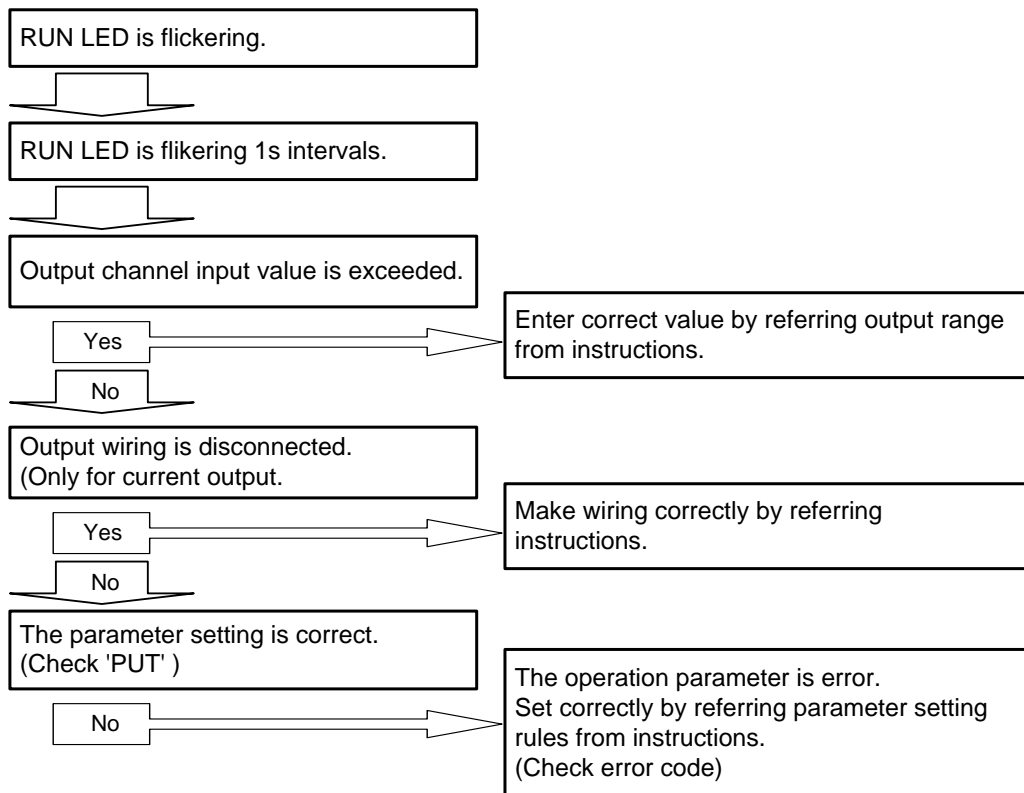

(3) The analog output value is abnormal.

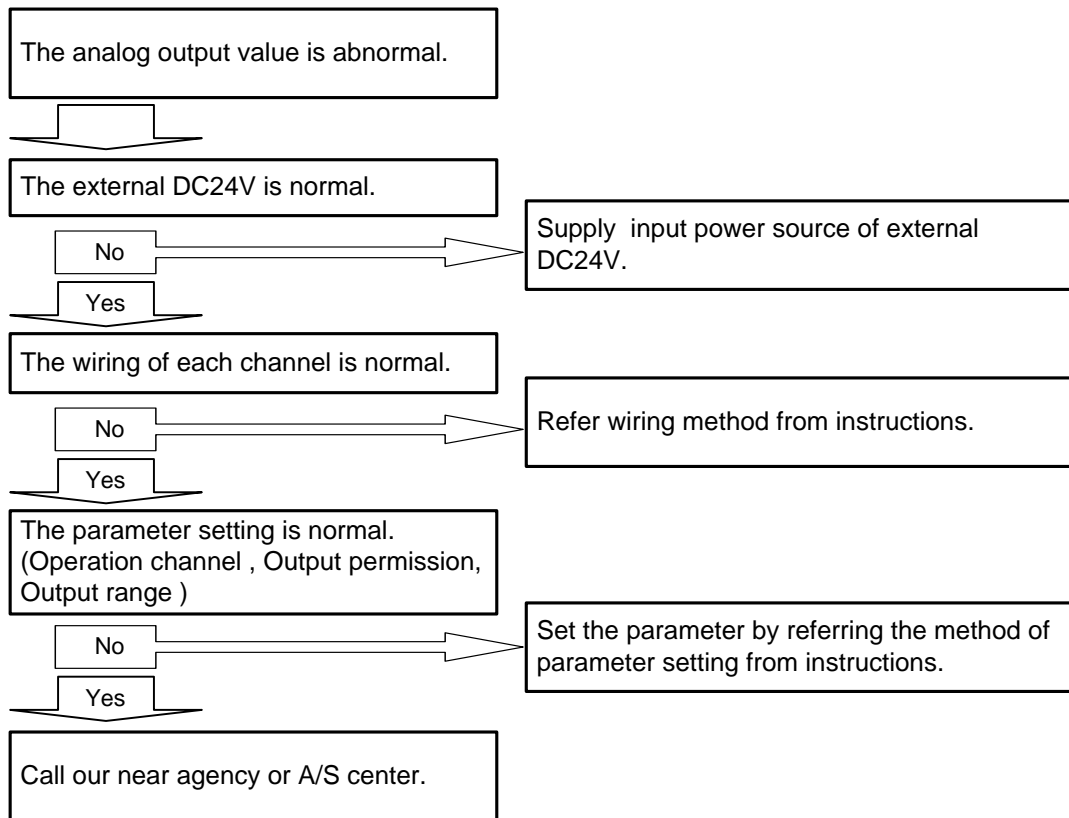

## 15. 1General

### 15.1.1 General

Here describes built-in PID (Proportional Integral Derivative) function. When there is plant (target of control), Control means that the user changes the status such as velocity, temperature, position, voltage, current etc. as the user wishes. Here describes PID control that is most frequently used among diverse control methods. Basic concept of PID control is as follows. First, it detects the PV (Process Value) through sensor and calculates what the difference with SV (Set value) is. Then it outputs MV (Manipulated Value) for PV to be same with SV.

At this time, 3 types of operation, such as Proportion, Integration, Derivation is executed according to the requirement of the user. PID control has high compatibility, flexibility, affordability in comparison with Robust control and Linear optimal control. In case of other control methods, since control device can be applied to the system after mathematical analysis of system, if system or the requirement of the user changes, the analysis of system is done again. But in case of PID control, PID device copes with change of system or requirement of the user with simple auto-tunings without analysis of system rapidly.

The figure 6.1 is example indicating system configuration of temperature control of heating system.

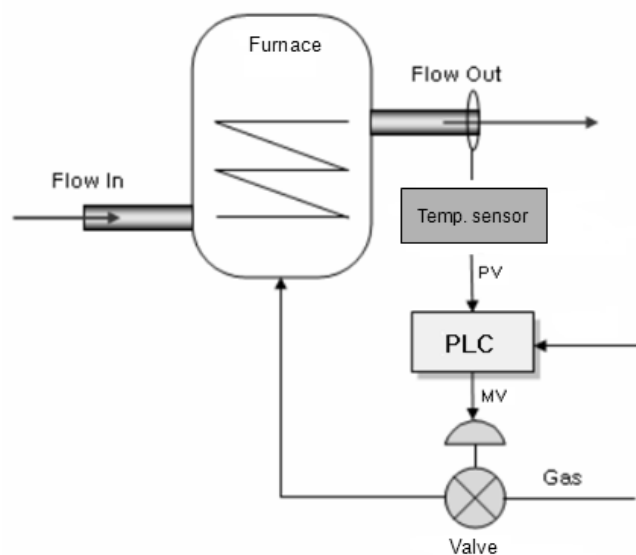

< Figure 15.1 PID Temperature control system with PLC >

At this time, PLC becomes control device for this system, output temperature of heating system becomes target for control. And temperature sensor and valve becomes devices to detect and manipulate the status of system respectively. If temperature sensor detects the output temperature and inputs that to PLC, PLC manipulate the valve status through PID operation and control the quantity of gas that goes into heating system. So temperature of heating system changes. This process is called control loop and PID control is executed by repeating the control loop. The control loop is repeated with a cycle of ms ~ s.

### 15.1.2 Features

The built-in PID control functions of XGB series feature as follows.

- (1) Since operations are executed within CPU part, it can be controlled by PID parameters and PLC program without PID module.
- (2) A variety of controls can be selected
  - That is, a user can easily select P operation, PI operation and PID operation.
- (3) Precise control operation
  - It can make precise PID control operations possible through floating point operations.
- (4) PWM (Pulse Width Modulation) output available.
  - It outputs control operation results to the output contact point designated by a user through PWM.
- (5) Improving convenience of control settings and monitoring
  - Through parameter setting method and K area flag, it maximizes control parameter settings during operation and convenience of monitoring
- (6) Freely selectable operation direction
  - Forward, reverse and mixed forward/reverse operations are available
- (7) Cascade operation realizing quick and precise PID control
  - It can increase quickness of response to disturbance through cascade loop.
- (8) Various additional functions
  - PID control can be achieved by various methods a user wishes because set value ramp, the present value follow-up, limiting change of values and types of alarm functions are provided.

## 15.2 PID Control

### 15.2.1 Basic theory of PID control

Here describes basic theory of PID control and how to configure PID control.

(1) Terms

Terms used in this user manual are as follows.

- PV: status of plant detected by sensor (Process value)
- SV: Target value (Set Value) to control plant, if control is done normally, PV should follow the SV.
- E: error between SV and PV. It can be expressed as (SV-PV).
- Kp: proportional coefficient
- Ti: Integral time constant. Sometimes called integral time
- Td: Derivative time constant. Sometimes called derivative time
- MV: Control input or control device output. The input to plant to make PV follow the V
- Ts: Sampling time, a cycle of operation to execute PID control

(2)PID operation expression

Basic PID operation expressions are as follows.

$$E = SV - PV \tag{15.2.1}$$

$$MV_P = K_P E \tag{15.2.2}$$

$$MV_i = \frac{K_P}{T_i} \int E dt \tag{15.2.3}$$

$$MV_d = K_P T_d \frac{dE}{dt} \tag{15.2.4}$$

$$MV = MV_P + MV_i + MV_d \tag{15.2.5}$$

PID control operation expressions of XGB series are more complicate than expression (15.2.1) ~ (15.2.5) mathematically but those are base on the above expression. The followings describe the characteristics of control process with an example that controls the output temperature of heating system in figure 15.1. At this example, the system and PID parameters imaginary to help the comprehension and those may be different with real heating system. If the heating system in figure 15.1 is expressed as second order system with transfer function like expression (15.2.6) in frequency domain, it is expressed as differential equation like expression (15.2.6) in the time domain.

$$\text{Transfer function} = \frac{32}{(2s + 1)(3s + 5)} \tag{15.2.6}$$

$$\frac{6}{32} \frac{d^2 y(t)}{dt^2} + \frac{13}{32} \frac{dy(t)}{dt} + 5y(t) = x(t) \tag{15.2.7}$$

That is, x(t) is Manipulated value and y(t) is Process value.

At this system, we assume that the PID parameter is specified as shown below to describe the PID control operation.

Items	Value	Items	Value
Output temperature of heating system (PV)	0°C	Proportional coefficient (K <sub>P</sub> )	5
Target temperature (SV)	50°C	Integral time (T <sub>i</sub> )	3s
Cycle of operation	0.01s	Derivative time (T <sub>d</sub> )	0.19s

<Table 15.1 example of control of heating system>

At this system, if we assume that target value of output temperature is 50°C and initial value of output temperature is 0°C, SV and PV becomes 50 and 0 respectively. In case of this, PID controller acts as follows.

(3) Proportional control (P control)

In the proportional control, the controller yields output that is proportional to error. Manipulated value of controller by Proportional control is as follows.

$$MV_P = E \times K_P \tag{15.2.8}$$

(a) If P control starts, output of controller by initial P operation is as follows.

$$MV_0 = 50 \times 4 = 200$$

If P control is executed for 10 seconds, output temperature will be as table 15.2. If this is expressed with graph, it will be as Figure 15.2.

Time	Target temp.	Proportional coefficient	Output temp.	Error
0	50	5	0	50
1	50	5	44.98	5.02
2	50	5	53.08	-3.08
3	50	5	50.15	-0.15
4	50	5	48.42	1.58
5	50	5	48.28	1.72
6	50	5	48.44	1.56
7	50	5	48.49	1.51
8	50	5	48.49	1.51
9	50	5	48.49	1.51

< Table 15.2 example of Proportional control >

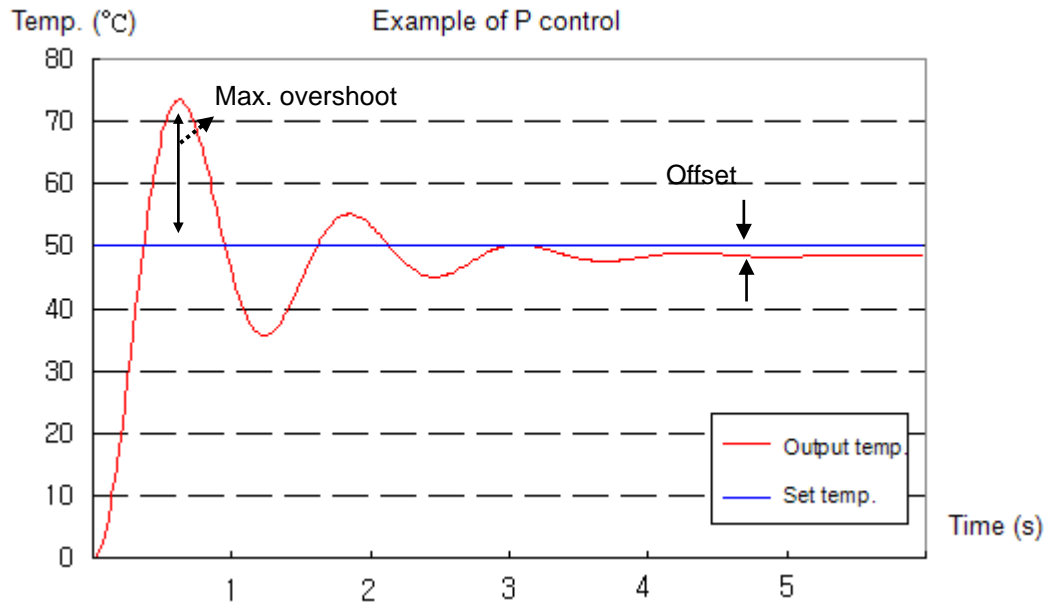

< Figure 15.2 simulation of proportional control >

- (b) Concerning the result of simulation, it has the maximum overshoot of about 23.4°C at 0.62s and after 7s, it converges at 48.49°C with offset of 1.51°C (about 3%).
- (c) Offset is an unavoidable error when only P control is executed. Offset decreases proportional to P coefficient but overshoot increases proportional to P coefficient. Table 15.3 and Figure 15.3 is simulation of offset and overshoot according to P coefficient.

Time	Target temperature	Kp = 5	Kp = 2.5	Kp = 1
0	50	0	0	0
1	50	45.02	63.46	46.67
2	50	53.11	42.52	46.77
3	50	50.15	47.93	41.38
4	50	50.22	47.25	41.60
5	50	48.27	46.96	43.30
6	50	48.35	46.92	43.25
7	50	48.44	46.90	43.21
8	50	48.53	46.90	43.18
9	50	48.53	46.90	43.18

<Table 15.3 Temperature- time table according to P coefficient>

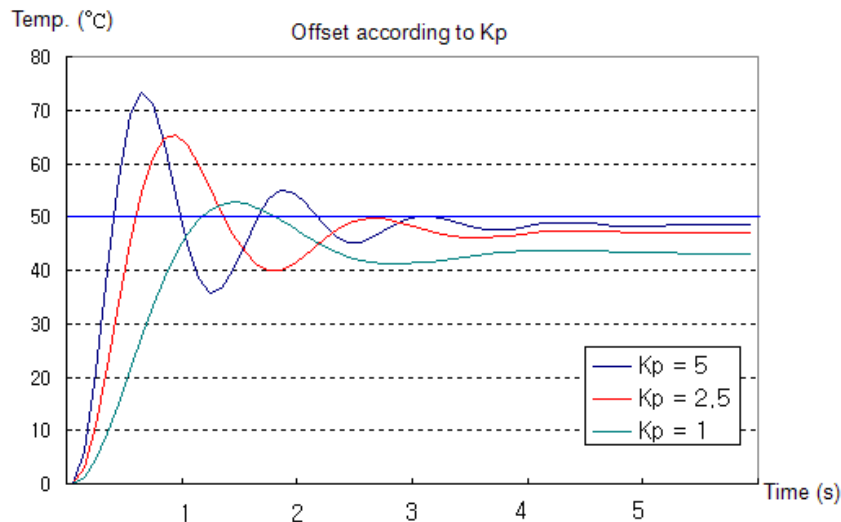

< Figure 15.3 Temperature- time graph according to P coefficient >

- (c) Considering table 15.3, as P coefficient decreases, offset increases but overshoot decreases.
- (d) Generally, offset can't be solved with only P control. In order to remove the offset, P control and I control is used together.

(4) Proportional Integral Control (PI Control)

In I control, it yields the output proportional to error accumulated according to time. And the expression is as follows.

$$MV_i = \frac{K_P}{T_i} \int E dt \tag{15.2.9}$$

- (a) In the expression 15.2.9,  $T_i$  means the time takes for  $MV_i$ , output by I control, to be added into real output.
- (b) Generally, I control is used with P control. So the expression of PI control is as follows.

$$MV = MV_P + MV_i = E \times K_P + \frac{K_P}{T_i} \int E dt \tag{15.2.10}$$

- (c) In the above heating system, the simulation results are as shown in the table 15.4 when proportional coefficient is 2.5 and integral time is 1.5s.

Time	Target temp.	Proportional coefficient	Integral time	P Control	PI Control
0	50	2.5	1.5	0	0
1	50	2.5	1.5	63.46	74.41
2	50	2.5	1.5	42.52	40.63
3	50	2.5	1.5	47.93	52.99
4	50	2.5	1.5	47.05	49.67



Time	Target temp.	Proportional coefficient	Integral time	P Control	PI Control
5	50	2.5	1.5	46.96	49.70
6	50	2.5	1.5	47.12	50.38
7	50	2.5	1.5	47.03	49.76
8	50	2.5	1.5	47.07	50.14
9	50	2.5	1.5	47.06	49.94
10	50	2.5	1.5	47.06	50.02
11	50	2.5	1.5	47.06	49.99
12	50	2.5	1.5	47.06	50.00
13	50	2.5	1.5	47.06	50.00
14	50	2.5	1.5	47.06	50.00
15	50	2.5	1.5	47.06	50.00

< Table 15.4 Temp.- time table >

- (d) Considering table 15.4 and Figure 15.4, if P and I control is used together, offset is removed and temp. converges at 50°C, target temp. after 12s
- (e) But in this case, convergence time is longer than that of P control and overshoot is larger. Generally, as integral time increases, overshoot decrease. About this, refer to the Figure 15.5.

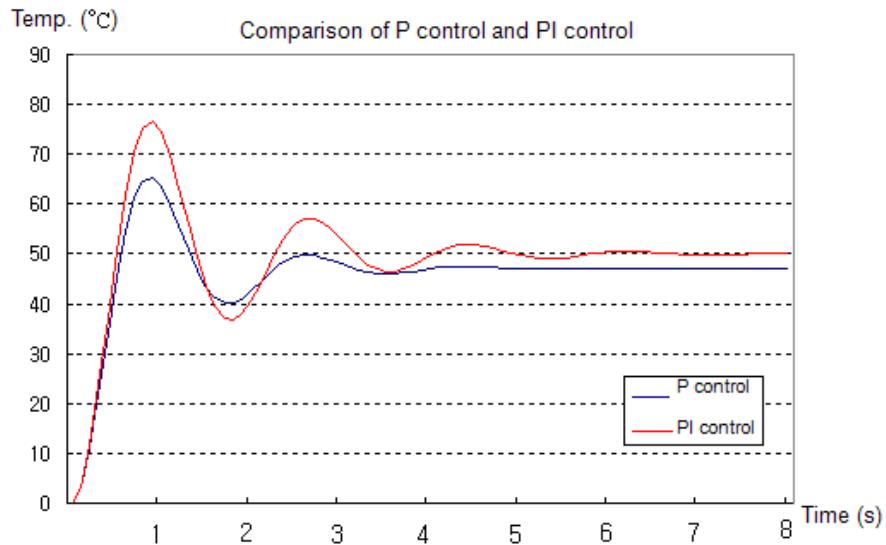

< Figure 15.4 Temp.- time graph >

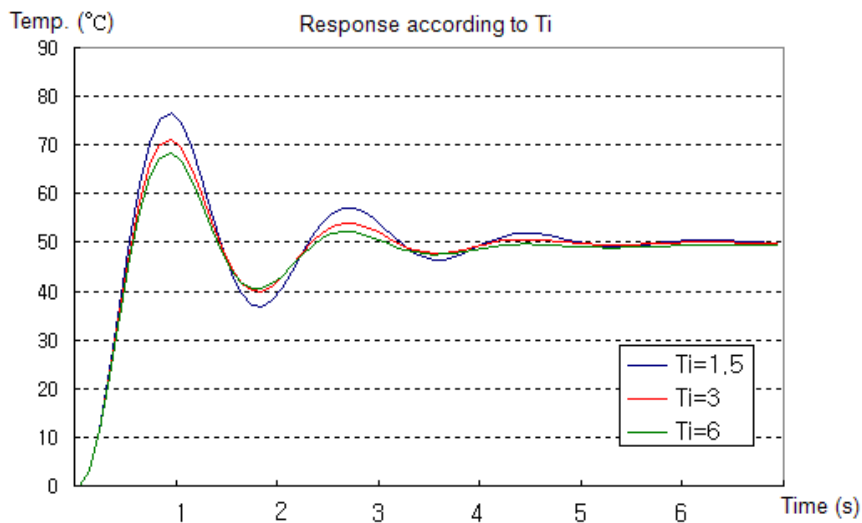

< Figure 15.5 overshoot according to integral time >

(f) Like this, if I control is used, overshoot is larger. According to system, large overshoot can be problem. In order to solve this, PID control is used.

(5) Proportional integral derivative control (PID control)

In D control, when status of system changes rapidly, D control yields the output to reduce the error. Namely, D control yields the output proportional to change velocity of current status. So if D control is used, response speed of controller about status change of system increases, and overshoot decreases. Output of controller by D control is as shown in expression 15.2.11.

$$MV_d = K_p T_d \frac{dE}{dt} \quad (15.2.11)$$

(a) In the expression 15.2.11,  $T_d$  means the time takes for  $MV_d$  output by I control, to be added into real output.

(b) Generally, D control is not used solely but with PD control. So PID control is expressed as expression 15.2.12.

$$MV = MV_p + MV_i + MV_d = E \times K_p + \frac{K_p}{T_i} \int E dt + K_p T_d \frac{dE}{dt} \quad (15.2.12)$$

(c) The Figure 15.6 is simulation result when PID control is applied to above heating system.

Time	Target temp.	Proportional coefficient	Integral time	Derivative time	PI Control	PID Control
0	50	2.5	1.5	0.3	0	0
1	50	2.5	1.5	0.3	74.41	55.50
2	50	2.5	1.5	0.3	40.63	56.33
3	50	2.5	1.5	0.3	52.99	52.50
4	50	2.5	1.5	0.3	49.67	50.92
5	50	2.5	1.5	0.3	49.70	50.34
6	50	2.5	1.5	0.3	50.38	50.12
7	50	2.5	1.5	0.3	49.76	50.05
8	50	2.5	1.5	0.3	50.14	50.02
9	50	2.5	1.5	0.3	49.94	50.01
10	50	2.5	1.5	0.3	50.02	50.00
11	50	2.5	1.5	0.3	49.99	50.00
12	50	2.5	1.5	0.3	50.00	50.00
13	50	2.5	1.5	0.3	50.00	50.00

< Table 15.5 comparison of PI control and PID control >

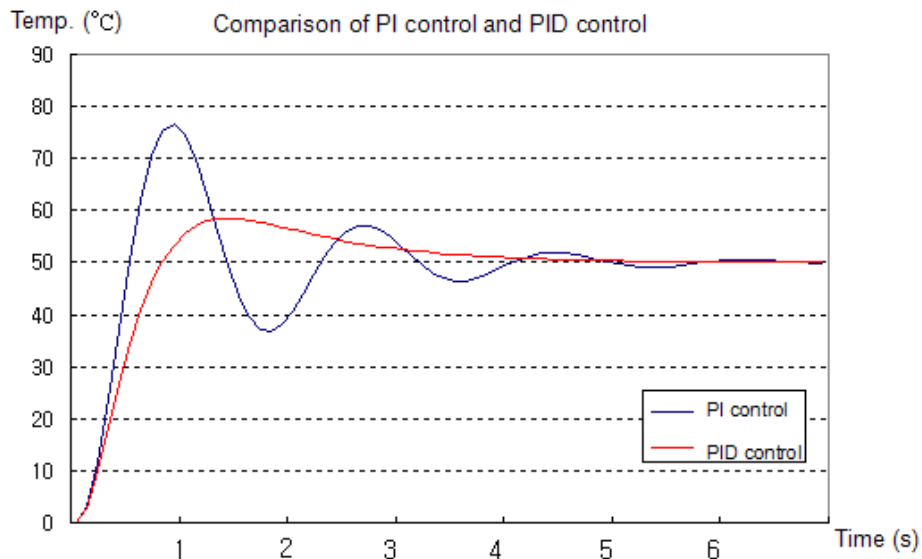

< Figure 15.6 comparison of PI control and PID control >

(d) Considering table 15.5, in case PID control is used, max. overshoot decreases from 16.5°C to 8.5°C. At this time, P coefficient, integral time, derivative time are not optimal values, just one of the examples. Actually, P coefficient, integral time, derivative time values vary according to PID control system.

## 15.2.2 Functional specifications of PID control

### (1) Functional Specifications

The performance specifications of the built-in PID control function in XGB series are summarized in the below table.

Item		Specifications
No. of loops		16 Loop
Scope of setting PID constants	Proportional constant(P)	Real number (0 ~ 3.40282347e+38)
	Integral constant(I)	Real number (0 ~ 3.40282347e+38), unit: second
	Differential constant(D)	Real number (0 ~ 3.40282347e+38), unit: second
Scope of set value		INT (-32,768 ~ 32,767)
Scope of present value		INT (-32,768 ~ 32,767)
Scope of maneuver value		INT (-32,768 ~ 32,767)
Scope of manual maneuver value		INT (-32,768 ~ 32,767)
Indication	RUN/STOP	Operation: PID RUN Flag On (by loops) Stop: PID RUN Flag Off (by loops)
	Error	Normal: PID Error Flag Off (by loops) Error: PID Error Flag On, Error code occurrence (by loops)
	Warning	Normal: PID Warning Flag Off (by loops) Error: PID Warning Flag On, Warnig code occurrence (by loops)
Control operation		Control of P,PI,PD and PID, control of forward/reverse operation
Control interval		10.0ms ~ 6,553.6ms (0.1msUnit)
Additional functions	PWM output	Supportable
	Mixed forward/reverse output	Supportable
	Limiting change of present value	INT (-32,768 ~ 32,767)
	Limiting change of maneuver value	INT (-32,768 ~ 32,767)
	Equally dividing set value	0 ~ 65,536 (frequency of control cycle time)
	Present value follow-up	0 ~ 65,536 (frequency of control cycle time)
	Cascade control	Supportable.
	Min./max. present value	-32,768 ~ 32,767
	Differential filter	0.01 ~ 655.35 (x 100 Scaled Up)
	Dead band setting	0 ~ 65,535
	Prevention of dual integral accumulation	Supportable
	PID operation pause	Supportable

< Table 15.6 built-in PID control performance specification >

### 15.2.3 PID control parameter setting

To use the built-in PID control function of XGB series, it is necessary to set PID control parameters by loops in the parameter window and operate it through the commands. Here, it explains parameters to use PID control functions and how to set them.

(1) PID parameter settings

Follow the steps below to set the PID control function parameters of XGB series.

- (a) If selecting the built-in parameters in Parameter of the project window, it shows the built-in parameter setting window as in below figure.

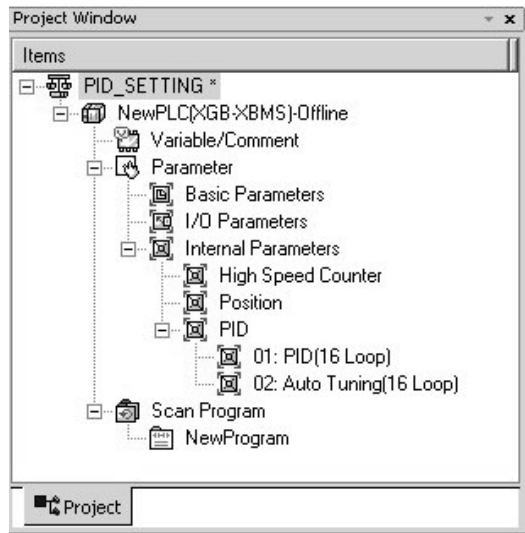

< Figure 15.7 Parameters setting window >

- (b) If selecting PID Control, it shows the PID control parameter setting window as in below figure.

Parameter	LOOP 0	LOOP 1	LOOP 2	LOOP 3
Operational Mode	Auto Opr	Auto Opr	Auto Opr	Auto Opr
Operational Direction	Forward	Forward	Forward	Forward
Secondary Anti windup	Disable	Disable	Disable	Disable
Derivative term Cal. Method	By Error	By Error	By Error	By Error
Enable PWM Output	Disable	Disable	Disable	Disable
Set Value	0	0	0	0
Scan Period	100	100	100	100
Proportional Gain	1	1	1	1
Integral Time	0	0	0	0
Derivative Time	0	0	0	0
Delta PV Limit	0	0	0	0
Delta MV Limit	0	0	0	0
Max. MV	4000	4000	4000	4000
Min. MV	0	0	0	0
Manual MV	0	0	0	0
DeadBand Setting Value	0	0	0	0
Set filtering coefficient	0	0	0	0
PWM Contact	P20	P20	P20	P20
PWM Output Period	100	100	100	100
Set SV Ramp	0	0	0	0
Set PV Tracking	0	0	0	0
Min PV	0	0	0	0
Max PV	4000	4000	4000	4000

[ Figure 15.8 Built-in PID function parameters setting window ]

(c) Input items

The items to set in the built-in PID function parameter window and the available scope of them are summarized in below table.

Items	Description	Scope
RUN mode	Set the operation mode of PID control.	Auto/manual operation
RUN direction	Set the operation direction of PID control.	Forward/reverse
Prevention of dual integral accumulation	Set whether to allow dual integral accumulation.	Disabled/enabled
PWM output	Set whether to allow PWM output of maneuver value.	Disabled/enabled
Operation cycle time	Set the operation cycle time of PID control cycle.	100 ~ 65535
Set value	Set target control value.	-32,768 ~ 32,767
Proportional gain	Set proportional gain.	Real number
Integral time	Set integral time.	Real number
Differential time	Set differential time.	Real number
Limiting change of present value	Set the limited change of present value per operation cycle.	-32,768 ~ 32,767
Limiting change of maneuver value	Set the limited change of maneuver value per operation cycle.	-32,768 ~ 32,767
Max. maneuver value	Set the max. maneuver value for control.	-32,768 ~ 32,767
Min. maneuver value	Set the min. maneuver value for control.	-32,768 ~ 32,767
Manual maneuver value	Set the manual maneuver value for control.	-32,768 ~ 32,767
DeadBand setting	Set the deadband width of the set value.	0 ~ 65,535
Differential filter value	Set the filter coefficient of differential operation.	0 ~ 65,535
PWM junction	Set the junction to which PWM output is out.	P20 ~ P3F (%QX0.0.0~%QX0.0.31)
PWM output cycle	Set the output cycle of PWM output.	100 ~ 65,535
Set value ramp	Set the frequency of set value ramp.	0 ~ 65,535
Present value follow-up	Set the follow-up frequency of the present value follow-up function.	0 ~ 65,535
Min. present value	Set the min. value of the input present value.	-32,768 ~ 32,767
Max. present value	Set the max. value of input present value.	-32,768 ~ 32,767

&lt; Table 15.7 PID function parameter setting items &gt;

(2) Description of Setting of PID Parameters

(a) Operation mode

It is the mode to set the operation for PID control of a loop in question.

The available scope is automatic operation or manual operation.

If automatic operation is selected, it outputs the PID control result internally operated by the input PID control parameter as the maneuver value while if manual operation is selected, it outputs the value input to the manual maneuver value parameter without PID operation modified. The default is automatic operation.

(b) Operation direction

It is designed to set the operation direction for PID control of a loop in question. The available scope is forward or reverse direction. At the moment, forward direction means increase of PV when MV increases; reverse direction means decrease PV when MV increases. For instance, a heater is a kind of forward direction system because PV(temperature) increases when output(heating) increases. A refrigerator is a kind of reverse direction system in which PV(temperature) decreases when output increases.

(c) Prevention of dual integral accumulation

It makes dual integral accumulation function enabled/disabled. To understand integral accumulation prevention function, it is necessary to explain the phenomenon of integral accumulation first of all. Every drive has a limit. That is, a motor is limited to the speed and a valve can become status overcoming the complete open/close. If it happens that MV output from a control is beyond the output limit of a drive, its output is maintained as saturated, which may deteriorate the control performance of a system and shorten the life of a drive. Formula (7.2.3) shows that the integral control among PID control output components accumulates errors as time goes on, from which it may take more time to return the normal status after the actuator is saturated in a system of which response characteristically is slow. It is so called integral accumulation phenomenon as illustrated in Fig. 7.9, which shows that if the initial error is very large, the error is continuously accumulated by integral control. Accordingly, a drive is saturated within its output upper limit while the control signal is getting larger, keeping being saturated for a long while until the drift becomes negative and the integral term turns small enough. Due to the operation, the PV may have a large over-shoot as seen in the figure. Such a wind-up phenomenon may occur if the initial drift is large or by a large disturbance or due to malfunction of a device.

The PID function of XGB series is basically with the integral accumulation prevention function, cutting off any integral accumulation phenomenon. In addition, it can detect a time when SV is suddenly decreased, providing a more strong dual integral accumulation prevention function.

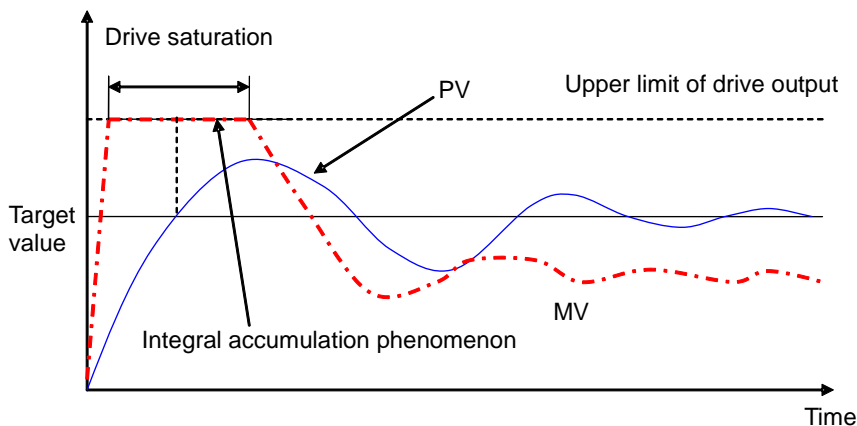

< Figure 15.9 Integral accumulation phenomenon >

(d) PWM Output Enabled

PWM output means an output method to turn a junction on – off with a duty proportional to control output calculated by a uniform output cycle. If PWM output is enabled, it realizes PWM output in

accordance with PWM output cycle set in the parameter of PWM output junction(P20 ~ P3F) designated in the parameter. At the moment, the PWM output cycle follows the PWM output cycle separately set in PID operation cycle. PWM output cycle is available between 10ms ~ 6553.5ms (setting value: 100 ~ 65,535) while it is set at a unit of integer per 0.1ms. figure shows the relation between PID control output and PWM output.

Ex) if PWM output cycle: 1 second, PWM output junction: P20, max. output: 10000, min. output: 0

Time	Output	P40 junction operation
0 sec	5000	0.5 sec On, 0.5 sec Off
1 sec	3000	0.3 sec On, 0.7 sec Off

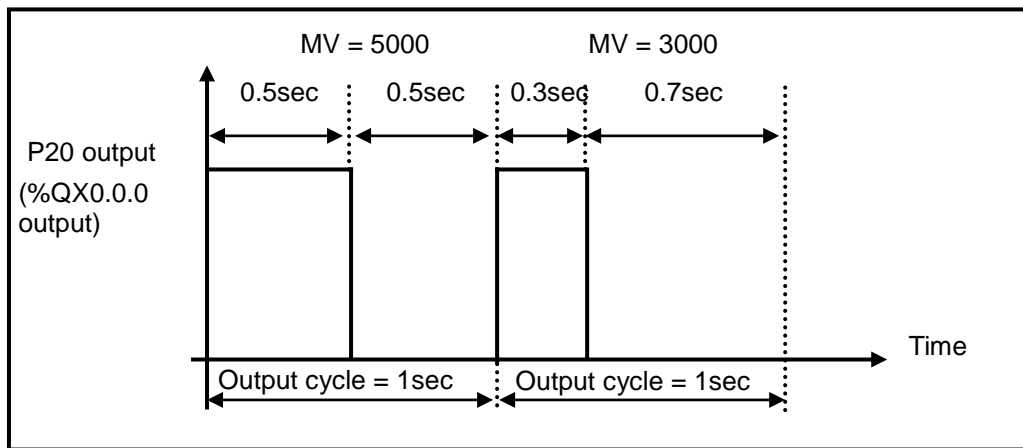

[ Figure 15.10 Relation between PWM output cycle and MV ]

(e) Set value

It sets the target of a loop in question, that is, the target status a user wishes to control. In case of the PID control built in XGB, physical values (temperature, flow rate, pressure and etc) of an object to control is not meaningful and instead, it should use the physical amount of an object to control after converting them into numerals. For instance, in order to control a system using a sensor that the output is 0V when its heating device temperature is 0°C while it is 10V when the temperature is 100°C as much as 50°C, it is necessary to set SV as 2000 (as long as it uses AD input module XBE-AD04A).

(f) Operation cycle

It sets the cycle to yield control output by executing the built-in PID operation. The setting cycle is 0.1ms and available between 10ms ~ 6553.5ms (setting value: 100 ~ 65,535) while it is set at a unit of integer per 0.1ms. For instance, to set PID operation per 100ms, set the operation cycle as 1000.

(g) Proportional gain

It is intended to set the proportional coefficient of a PID loop in question (Kp). As larger Kp, the proportional control operation is getting stronger. The scope is real number.

(h) Integral time

It sets the integral time of PID loop in question (Ti). As larger the integral time, the integral operation is getting weaker. The scope is real number at the unit of second.



(i) Differential time

It sets the differential time of PID loop in question ( $T_d$ ). As larger the differential time, the differential operation is getting stronger. The scope is real number at the unit of second.

(j) Limiting change of present value

It sets the limit of change in present value of PID loop in question. If PV suddenly changes due to signal components such as sensor's malfunction, noise or disturbance during control of PID, it may cause sudden change of PID control output. To prevent the phenomenon, a user can set the max. limit of change in present value that is allowed per PID operation cycle. If the change of present value is limited accordingly, it may calculate the present value as much as the limit although the present value is changed more than the limit once the limit of change in present value is set. If using the PV change limit function, it may prevent against sudden change of control output owing to noise or etc. If it is, however, set too small, it may reduce the response speed to the PV change of an actual system, not to sudden change by noise or etc, so it is necessary to set the value appropriately according to the environment of a system to control in order that the PV toward the set value does not take a longer time. The available scope is between -32,768 ~ 32,767. If setting the PV change limit as 0, the function is not available.

(k) Limiting change of MV ( $\Delta$ MV function)

It limits the max. size that control output, which is output by PID operation is changed at a time. The output MV in this operation cycle is not changed more than the max. change limit set in the previous operation cycle. The function has an effect to prevent a drive from operating excessively due to sudden change of output by preventing sudden change of output resulting from instantaneous change of set value. If it is, however, set too small, it may cause taking a longer time until PV reaches to its target, so it is necessary to adjust it appropriately. The available scope is between -32,768 ~ 32,767. If setting it as 0, the function does not work.

(l) Max. MV

It sets the max. value of control output that may be output by the result of PID operation. The available scope is between -32,768 ~ 32,767. If it exceeds the max. output designated by PID operation result, it outputs the set max. output and alerts the max. output excess warning. For the types and description of warnings, refer to Error/Warning Codes.

(m) Min. MV

It sets the min. value of control output that may be output by the result of PID operation. The available scope is between -32,768 ~ 32,767. If it is smaller than the min. output value designated by PID operation result, it outputs the set min. MV and alerts the min. output shortage warning. For the types and description of warnings, refer to Error/Warning Codes.

(n) Manual MV

It sets the output when the operation mode is manual. The available scope is between -32,768 ~ 32,767.

(o) DeadBand setting

It sets the deadband between set value and present value. Although it may be important to reduce normal status reply of PV for its set value even when MV fluctuates heavily, depending on control system, it may be more important to reduce the frequent change of MV although the normal status reply is somewhat getting larger. DeadBand may be useful in the case. Below figure shows an example of DeadBand setting.

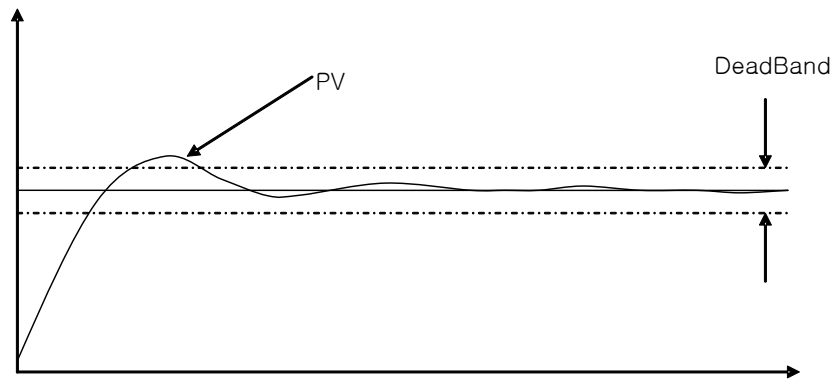

[ Figure 15.11 Example of DeadBand setting ]

If setting deadband as in the figure, the PID control built in XGB may regard the error between PV and set value as 0 as long as PV is within the available scope of deadband from set value.

That is, in this case, the change of MV is reduced. The available scope of setting is between 0 ~ 65,535 and if it is set as 0, it does not work.

(p) Differential Filter Value Setting

It sets the coefficient of differential filter. Since differential control outputs in proportion to gradient of error and gradient of PV change, it may suddenly change MV as it generates a large response to instantaneous noise or disturbance. To prevent it, XGB series uses a value to which PV is filtered mathematically for differential control. Differential filter value is the coefficient to determine the filter degree for differential control. As smaller differential value set, as stronger differential operation is. The available scope is between 0 ~ 65,535 and if it is set as 0, the differential filter does not work.

(q) Setting set value ramp

Since the drift is suddenly large if SV is heavily changed during PID control, MV is also changed heavily to correct it. Such an operation may cause excessive operation of a system to control and a drive. To prevent it, SV ramp is used, changing SV gradually step by step when modifying SV during operation. If using the function, SV is gradually changed by SV ramp when SV is changed during PID control. At the moment, SV ramp setting represents the frequency of PID operation cycle taken from when SV starts changing to when it reaches to the final SV. For instance, if SV is to be changed from 1000 to 2000 during operation as PID operation cycle is 10ms and its SV ramp is 500, SV may reach to 2000 after  $500 \times 10\text{ms} = 5$  seconds, that is, as it increases each 2 per operation cycle and after the 500th operation scans. The available scope of setting is between 0 ~ 65,535 and it is set as 0, it does not work.

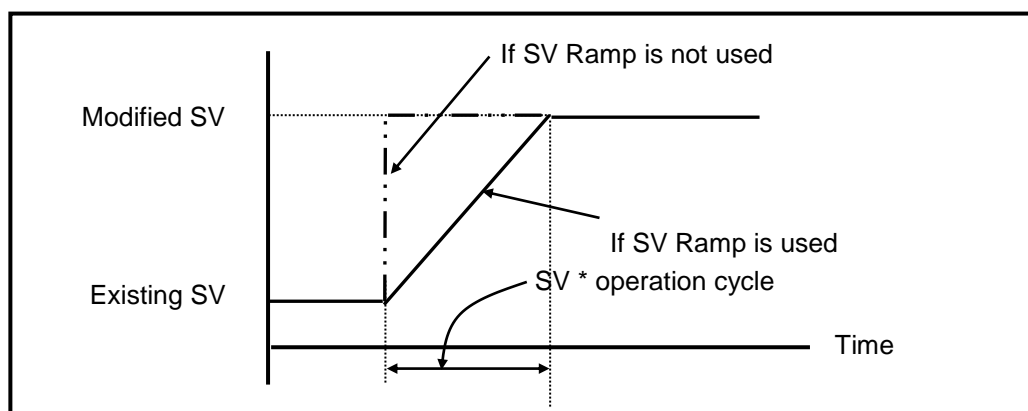

[ Figure 15.12 SV Ramp function ]

(r) PV Follow-up setting

It is intended to prevent any excessive operation of a drive resulting from sudden change of output at the initial control and changes SV gradually from PV at the time when PID operation starts, not directly to SV in case control just turns from stop to operation mode or it changes from manual to automatic operation. At the moment, SV represents the frequency of PID operation cycles taken from when control starts to when it reaches to the set SV (other operations are same as SV ramp function). The available scope is between 0 ~ 65,535. If SV is changed again while PV follow-up is in operation, the SV would be also changed according to SV ramp.

(s) Min./max. PV

It sets the min./max. value entered as the present value of PID control. The available scope is between -32,768 ~ 32,767.

### 15.2.4 PID flag

The parameter set by the XGB series built-in PID control function is saved into the flash memory of the basic unit. Such parameters are moved to K area for the built-in PID function as soon as PLC turns from STOP to RUN mode. PID control operation by PID control command is executed through K area data for PID functions. Therefore, if a user changes the value in the trend monitor window or variable monitor window during operation, PID operation is executed by the changed value. At the moment, if PLC is changed to RUN again after being changed to STOP, it loads the parameters in flash memory to K area, so the data changed in K area is lost. Thus, to keep applying the parameters adjusted in K area, it is necessary to write the parameter set in K area to flash memory by using WRT command. (In case of IEC, APM\_WRT)

#### (1) PID Flag Configuration

K area flags for XGB series built-in PID control function are summarized in the below table.

Loop	K area	IEC type	Symbol	Data type	Default	Description
Common	K12000~F	%KX19200~15	_PID_MAN	Bit	Auto	PID output designation(0:auto, 1:manual)
	K12010~F	%KX19216~31	_PID_PAUSE	Bit	RUN	PID pause (0:RUN, 1:pause)
	K12020~F	%KX19232~47	_PID_REV	Bit	Forward	Control direction(0:forward, 1:reverse) operation control
	K12030~F	%KX19248~63	_PID_AW2D	Bit	Disabled	Dual integral accumulation prevention(0:enabled, 1:disabled)
	K12040~F	%KX19264~79	_PID_REM_RUN	Bit	Disabled	PID remote operation(0:disabled, 1:enabled)
	K1205~K1207	%KW1205~%KW1207	Reserved	WORD	-	Reserved area
	K12080~F	%KX19328~43	_PID_PWM_EN	Bit	Disabled	PWM output enable(0:disabled, 1:enabled)
	K12090~F	%KX19344~59	_PID_STD	Bit	-	PID operation indication(0:stop, 1:run)
	K12100~F	%KX19360~75	_PID_ALARM	Bit	-	PID warning(0:normal, 1:warning)
	K12110~F	%KX19376~91	_PID_ERROR	Bit	-	PID error(0:normal, 1:error)
	K1212~K1215	%KW1212~%KW1215	Reserved	WORD	-	Reserved
Loop 0	K1216	%KW1216	_PID00_SV	INT	0	PID SV
	K1217	%KW1217	_PID00_T_s	WORD	100	PID operation cycle[0.1ms]
	K1218	%KD609	_PID00_K_p	REAL	1	PID proportional constant
	K1220	%KD610	_PID00_T_i	REAL	0	PID integral time[sec]
	K1222	%KD611	_PID00_T_d	REAL	0	PID differential time[sec]
	K1224	%KW1224	_PID00_d_PV_max	WORD	0	PID PV change limit
	K1225	%KW1225	_PID00_d_MV_max	WORD	0	PID MV change limit
	K1226	%KW1226	_PID00_MV_max	INT	4000	PID MV max. value limit
	K1227	%KW1227	_PID00_MV_min	INT	0	PID MV min. value limit
	K1228	%KW1228	_PID00_MV_man	INT	0	PID manual output
	K1229	%KW1229	_PID00_PV	INT	-	PID PV

< Table 15.8 K area flags for PID control >

Loop	K area	IEC type	Symbol	Data type	Default	Description
Loop 0	K1230	%KW1230	_PID00_PV_old	INT	-	PID PV of previous cycle
	K1231	%KW1231	_PID00_MV	INT	0	PID MV
	K1232	%KD616	_PID00_ERR	DINT	-	PID control error
	K1234	%KD617	_PID00_MV_p	REAL	0	PID MV proportional value component
	K1236	%KD618	_PID00_Mv_i	REAL	0	PID MV integral control component
	K1238	%KD619	_PID00_MV_d	REAL	0	PID MV differential control component
	K1240	%KW1240	_PID00_DB_W	WORD	0	PID deadband setting
	K1241	%KW1241	_PID00_Td_lag	WORD	0	PID differential filter coefficient
	K1242	%KW1242	_PID00_PWM	WORD	H'20	PID PWM junction setting
	K1243	%KW1243	_PID00_PWM_Prd	WORD	100	PID PWM output cycle
	K1244	%KW1244	_PID00_SV_RAMP	WORD	0	PID SV Ramp value
	K1245	%KW1245	_PID00_PV_Track	WORD	0	PID PV follow-up setting
	K1246	%KW1246	_PID00_PV_MIN	INT	0	PID PV min. value limit
	K1247	%KW1247	_PID00_PV_MAX	INT	4000	PID PV max. value limit
	K1248	%KW1248	_PID00_ALM_CODE	Word	0	PID warning code
	K1249	%KW1249	_PID00_ERR_CODE	Word	0	PID error code
	Loop 1	K1250	%KW1250	_PID00_CUR_SV	INT	0
K1251-1255		%KW1251-1255	Reserved	WORD	-	Reserved area
Loop 16	K1256-K1295	%KW1256~%KW1295	-	-	-	PID Loop1 control parameter
~						
Loop16	K1816-K1855	%KW1816~%KW1855	-	-	-	PID Loop16 control parameter

< Table 15.8 K area flags for PID control (continued) >

K1200 ~ K1211 areas are the common bit areas of PID loops while each bit represents the status of each PID control loop. Therefore, each 16 bits, the max number of loops of XGB PID control represents loop status and setting respectively. K1216 ~ K1255 areas are K areas for PID control loop 0 and save the loop 0 setting and status. It also contains parameters such as SV, operation cycle, proportional coefficient, integral time and differential time set in the built-in parameter window and the XGB built-in PID function executes PID control by each device value in question. In addition, the output data such as MV calculated and output while PID control is executed is also saved into the K areas. By changing the values in K areas, control setting may be changed any time during PID control.

<b>Remark</b>	By changing value of area, you can change control setting whenever you want during the PID control 1) PID control flag expression : _PID[n]_xxx ➔ [n] : loop number ➔ xxx : flag function Ex) _PID10_K_p : means K_p of loop 10.
---------------	--

## 2) PID flag function

Each function of K area flags for XGB series built-in PID control function is summarized as follows.

## (a) Common bit area

The area is a flag collecting operation setting and information consisting of bits to each 16 loop. Each bit of each word device represents the information of each loop. That is, 'n' th bit represents the information about PID loop n.

## 1) \_PID\_MAN (PID RUN mode setting)

Flag name	address	IEC type address	Unit	Setting
_PID_MAN (PID RUN mode setting)	K1200n	%KX19200 + n	BIT	Available

It determines whether to operate the PID control of n loop automatically or manually. For more information about RUN mode, refer to 6.2.3 PID control parameter setting. If the bit is off, it operates automatically; if on, it runs manually.

## 2) \_PID\_PAUSE (PID Pause setting)

Flag name	Address	IEC type address	Unit	Setting
_PID_PAUSE (PID pause setting)	K1201n	%KX19216 + n	BIT	Available

It changes PID control of n loop to pause status. If PID control is paused, the control MV is fixed as the output at the time of pause. At the moment, PID operation is continued internally with output fixed. If changing pause status to operation status again, it resumes control, so it may take a longer time until the PV is going to SV once system status is largely changed during pause. If the bit is off, it cancels pause; if on, it operates as paused.

## 3) \_PID\_REV (PID RUN direction setting)

Flag name	Address	IEC type address	Unit	Setting
_PID_REV (PID RUN direction setting)	K1202n	%KX19232 + n	BIT	Available

It sets the RUN direction of PID control of 'n'th loop. For more information about run direction, refer to 7.2.3 PID control parameter setting. If the bit is off, it operates normally; if on, it operates reversely.

## 4) \_PID\_AW2D (Dual Integral accumulation prevention setting)

Flag name	Address	IEC type address	Unit	Setting
_PID_AW2D (dual integral accumulation prevention setting)	K1203n	%KX19248 + n	BIT	Available

It sets enable/disable of dual integral accumulation prevention of 'n'th loop. For more information about dual integral accumulation prevention, refer to 7.2.3 PID control parameter setting. If the bit is off, it is enabled; if on, it is disabled.

5) \_PID\_REM\_RUN (PID remote operation setting)

Flag name	Address	IEC type address	Unit	Setting
_PID_REM_RUN (PID remote run setting)	K1204n	%KX19264 + n	BIT	Available

X  
GB series built-in PID function can be started by both run from command's start junction and remote run bit setting. That is, XGB starts PID control if PIDRUN command's start junction is on or remote run setting bit is on. Namely, if one of them is on, it executed PID control.

6) \_PID\_PWM\_EN (PWM output enable)

Flag name	Address	IEC type address	Unit	Setting
_PID_PWM_EN (PWM output enable)	K1208n	%KX19328 + n	BIT	Available

It determines whether to output the MV of PID control of 'n'th loop as PWM output. For more information about PWM output, refer to 15.2.3 PID control parameter setting. If the bit is off, it is disabled; if on, it is enabled.

7) \_PID\_STD (PID RUN status indication)

Flag name	Address	IEC type address	Unit	Setting
_PID_STD (PID RUN status indication)	K1209n	%KX19344 + n	BIT	Unavailable

It indicates the PID control RUN status of 'n' th loop. If a loop is running or paused, it is on while if it stops or has an error during RUN, it is off. In the area as monitoring area, it is changed to the current run status by PLC although a user enters any value temporarily.

8) \_PID\_ALARM (PID Warning occurrence)

Flag name	Address	IEC type address	Unit	Setting
_PID_ALARM (PID Warning occurrence)	K1210n	%KX19360 + n	BIT	Unavailable

It indicates warning if any warning occurs during PID control of 'n'th loop. Once a warning occurs during PID control operation of a loop, it is on while if it is normal, it is off. At the moment, despite of warning, PID control continues without interruption, but it is desirable to check warning information and take a proper measure. Once a warning occurs, the warning code is also indicated in warning code area of a loop. For more information about the types of warning codes and measures, refer to 15.5. In the area as monitoring area, it is changed to the current run status by PLC although a user enters any value temporarily.

9) \_PID\_ERROR (PID Error occurrence)

Flag name	Address	IEC type address	Unit	Setting
_PID_ERROR (PID error occurrence)	K1211n	%KX19376 + n	BIT	Unavailable

If an error that discontinues running during PID control of 'n' th loop occurs, it indicates the error's occurrence. If an error generates warning, it is on; if normal, it is off. When an error occurs, PID control stops and MV is output as the min. output set in parameter. Also, if an error

occurs, the error code is indicated in the error code area of a loop. For more information about type of error codes and measures, refer to 15.5. In the area as monitoring area, it is changed to the current run status by PLC although a user enters any value temporarily.

## (b) PID Flag area by loops

PID flag areas by loops are allocated between K1216 ~ K1855 and for totally 16 loops, each 40 words is allocated per loop. Therefore, the individual data areas of 'n' th loop are between K (1216+16\*n) ~ K (1255+16\*n). Every setting of the PID flag areas by loops may be changed during PID control operation. Once the settings are changed, they are applied from the next PID control cycle.

## 1) \_PIDxx\_SV (PID xx Loop SV setting)

Flag name	Address	IEC type address	Unit	Scope
_PIDxx_SV (PID xx Loop SV setting)	K1216+16*xx	%KW1216+16*xx	INT	-32,768 ~ 32,767

It sets/indicates the SV of PID control of 'xx' th loop. For more information about SV, refer to 15.2.3 PID control parameter setting. The available scope is between -32,768 ~ 32,767.

## 2) \_PIDxx\_T\_s (PID xx Loop operation cycle)

Flag name	Address	IEC type address	Unit	Scope
_PIDxx_T_s (PID xx Loop operation cycle)	K1217+16*xx	%KW1217+16*xx	WORD	100 ~ 65,535

It sets/indicates the operation cycle of PID control of 'xx' th loop. For more information about operation cycle, refer to 15.2.3 PID control parameter setting. The available scope is between 100 ~ 65,535.

## 3) \_PIDxx\_K\_p (PID xx Loop proportional constant)

Flag name	Address	IEC type address	Unit	Scope
_PIDxx_K_p (PID xx Loop proportional constant)	K1218+16*xx	%KD609+20*xx	REAL	Real number

It sets/indicates the proportional constant of PID control of 'xx' th loop. For more information about proportional constant, refer to 7.2.3 PID Control Parameter Setting. The available scope is real number (-3.40282347e+38 ~ -1.17549435e-38 , 0 , 1.17549435e-38 ~ 3.40282347e+38). If it is, however, set as 0 and lower, the PID control of a loop generates an error and does not work.

## 4) \_PIDxx\_T\_i (PID xx Loop Integral time)

Flag name	Address	IEC type address	Unit	Scope
_PIDxx_T_i (PID xx Loop integral time)	K1220+16*xx	%KD610+20*xx	REAL	Real number

It sets/indicates integral time of PID control of 'xx' th loop. The available scope is real number. If it is set as 0 and lower, it does not execute integral control.



5) `_PIDxx_T_d` (PID xx Loop differential time)

Flag name	Address	IEC type address	Unit	Scope
<code>_PIDxx_T_d</code> (PID xx Loop differential time)	K1222+16*xx	%KD611+20*xx	REAL	Real number

It sets/indicates differential time of PID control of 'xx' th loop. The available scope is real number. If it is set as 0 and lower, it does not execute differential control.

6) `_PIDxx_d_PV_max` (PV change limit)

Flag name	Address	IEC type address	Unit	Scope
<code>_PIDxx_d_PV_max</code> (PV change limit)	K1224+16*xx	%KD612+20*xx	WORD	0 ~ 65,535

It sets the PV change limit of 'xx' th loop. For more information about PV change limit, refer to 15.2.3 PID control parameter setting. If it is set as 0, the PV change limit function does not work.

7) `_PIDxx_d_MV_max` (MV change limit)

Flag name	Address	IEC type address	Unit	Scope
<code>_PIDxx_d_MV_max</code> (MV change limit)	K1225+16*xx	%KD610+20*xx	WORD	0 ~ 65,535

It sets the MV change limit of 'xx' th loop. For more information about MV change limit, refer to 15.2.3 PID control parameter setting. If it is set as 0, the MV change limit function does not work.

8) `_PIDxx_MV_max`, `_PIDxx_MV_min`, `_PIDxx_MV_man` (max. MV, min. MV, manual MV)

Flag name	Address	IEC type address	Unit	Scope
<code>_PIDxx_MV_max</code> (max. MV)	K1226+16*xx	%KW1226+16*xx	INT	-32,768 ~ 32,767
<code>_PIDxx_MV_min</code> (min. MV)	K1227+16*xx	%KW K1227+16*xx		
<code>_PIDxx_MV_man</code> (manual MV)	K1228+16*xx	%KW K1228+16*xx		

It sets the max. MV, min. MV and manual MV of 'xx' th loop. For more information about max. MV, min. MV and manual MV, refer to 15.2.3 PID control parameter setting. If the max. MV is set lower than the min. MV, the PID control loop generates an error and does not work.

9) `_PIDxx_PV` (prevent value)

Flag name	Address	IEC type address	Unit	Scope
<code>_PIDxx_PV</code> (present value)	K1229+16*xx	%KW1229+16*xx	INT	-32,768 ~ 32,767

It is the area that receives the present value of 'xx' th PID control loop. PV is the present status of the system to control and is normally saved into U device via input devices such as A/D input module if it is entered from a sensor. The value is used to execute PID operation by moving to `_PIDxx_PV` by means of commands like MOV.

10) `_PIDxx_PV_OLD` (PV of previous control cycle)

Flag name	Address	IEC type address	Unit	Scope
<code>_PIDxx_PV_OLD</code> (PV of previous control cycle)	K1230+16*xx	%KW1230+16*xx	INT	Unavailable

The area indicates the PV just before the xx th PID control loop. The flag, as a dedicated monitoring flag, would be updated by PLC although a user directly enters it.

## 11) \_PIDxx\_MV (Control MV)

Flag name	Address	IEC type address	Unit	Scope
_PIDxx_MV (control MV)	K1231+16*xx	%KW1231+16*xx	INT	Unavailable

The area shows the MV of 'xx' th PID control loop. As the area in which XGB built-in PID operation result is output every PID control cycle, it delivers the value in the area to U device every scanning by using commands like MOV in the program and outputs to D/A output module, operating a drive.

## 12) \_PID00\_ERR (Present error)

Flag name	Address	IEC type address	Unit	Scope
_PID00_ERR (present error)	K1232+16*xx	%KW1232+16*xx	DINT	Unavailable

The areas shows the current error of 'xx' th PID control loop. It is also used as an indicator about how much gap the present status has with a desired status and if an error is 0, it means the control system reaches a desired status exactly. Therefore, if control starts, error is quickly reduced at transient state and it reaches normal state, maintaining remaining drift as 0, it could be an ideal control system. The flag, as a dedicated monitoring, is updated although a user directly enters it.

## 13) \_PIDxx\_MV\_p, \_PIDxx\_MV\_i, \_PIDxx\_MV\_d (P/I/D control components of MV)

Flag name	Address	IEC type address	Unit	Scope
_PIDxx_MV_p (MV proportional control component)	K1234+16*xx	%KD616+20*xx	REAL	Unavailable
_PIDxx_MV_i (MV integral control component)	K1236+16*xx	%KD617+20*xx		
_PIDxx_MV_d (MV differential control component)	K1238+16*xx	%KD618+20*xx		

It indicates 'n' th loop MV by classifying proportional control MV, integral control max. MV and differential control MV. The entire MV consists of the sum of these three components. The flag, as a dedicated monitoring, is updated although a user directly enters it.

## 14) \_PIDxx\_DB\_W (DeadBand setting)

Flag name	Address	IEC type address	Unit	Scope
_PIDxx_DB_W (DeadBand setting)	K1240+16*xx	%KW1232+16*xx	WORD	0 ~ 65,535

It sets the deadband of 'xx' th loop. For more information about Deadband function, refer to 15.2.3 PID control parameter setting. If it is set as 0, the function does not work.

## 15) \_PIDxx\_Td\_lag (Differential filter coefficient)

Flag name	Address	IEC type address	Unit	Scope
_PIDxx_Td_lag (differential filter coefficient)	K1241+16*xx	%KW1241+16*xx	WORD	0 ~ 65,535

It sets the differential filter coefficient of 'xx' th loop. For more information about differential filter coefficient, refer to 15.2.3 PID control parameter setting. If it is set as 0, the function does not work.

16) \_PIDxx\_PWM (PWM output junction setting)

Flag name	Address	IEC type address	Unit	Scope
_PID00_PWM (PWM output junction setting)	K1242+16*xx	%KW1242+16*xx	WORD	H'20 ~ H'3F

It sets the junction to which PWM output of 'xx' th loop is output. PWM output junction is valid only between H'20 ~ H'3F. If any other value is entered, PWM output does not work.

17) \_PIDxx\_PWM\_Prd (PWM Output cycle setting)

Flag name	Address	IEC type address	Unit	Scope
_PIDxx_PWM_Prd (PWM output cycle setting)	K1243+16*xx	%KW1243+16*xx	WORD	100 ~ 65,535

It sets the PWM output cycle of 'xx' th loop. The available scope is between 100 ~ 65,535 at the unit of 0.1ms.

18) \_PIDxx\_SV\_RAMP (SV ramp setting)

Flag name	Address	IEC type address	Unit	Scope
_PIDxx_SV_RAMP (SV ramp setting)	K1244+16*xx	%KW1244+16*xx	WORD	0 ~ 65,535

It sets the SV ramp value of 'xx' th loop. For more information about SV ramp of PV, refer to 15.2.3 PID control parameter setting. If it is set as 0, the function does not work.

19) \_PIDxx\_PV\_Track (PV follow-up setting)

Flag name	Address	IEC type address	Unit	Scope
_PIDxx_PV_Track (PV follow-up setting)	K1245+16*xx	%KW1245+16*xx	WORD	0 ~ 65,535

It sets the PV follow-up SV of 'xx' th loop. For more information about PV follow-up, refer to 15.2.3 PID control parameter setting. If it is set as 0, the function does not work.

20) \_PIDxx\_PV\_MIN, \_PIDxx\_PV\_MAX (Min. PV input, Max. PV input)

Flag name	Address	IEC type address	Unit	Scope
_PIDxx_MV_p (MV proportional control component)	K1246+16*xx	%KW1246+16*xx	INT	-32,768 ~ 32,767
_PIDxx_MV_i (MV integral control component)	K1247+16*xx	%KW1247+16*xx		

It sets the min./max. PV of 'xx' th loop.

21) \_PIDxx\_ALM\_CODE (Warning code)

Flag name	Address	IEC type address	Unit	Scope
_PIDxx_ALM_CODE (Warning code)	K1248+16*xx	%KW1248+16*xx	WORD	Unavailable

It indicates warning code if a warning occurs during 'xx' th loop run. The flag, as a dedicated monitoring, is updated although a user directly enters it. For more information about warning code, refer to 15.5.

## 22) \_PIDxx\_ERR\_CODE (Error code)

Flag name	Address	IEC type address	Unit	Scope
_PIDxx_ERR_CODE (error code)	K1249+16*xx	%KW1249+16*xx	WORD	Unavailable

It indicates error code if an error occurs during 'xx' th loop run. The flag, as a dedicated monitoring, is updated although a user directly enters it. For more information about warning code, refer to 15.5.

## 23) \_PIDxx\_CUR\_SV (SV of the present cycle)

Flag name	Address	IEC type address	Unit	Scope
_PIDxx_CUR_SV (SV of the present cycle)	K1250+16*xx	%KW1250+16*xx	INT	Unavailable

It indicates SV currently running of 'xx' th loop. If SV is changing due to SV ramp or PV follow-up function, it shows the currently changing PV. The flag, as a dedicated monitoring, is updated although a user directly enters it.

## 15.3 PID Instructions

It describes PID control commands used in XGB series. The command type of PID control used in XGB series built-in PID control is 4.

(1) PIDRUN

PIDRUN is used to execute PID control by loops.

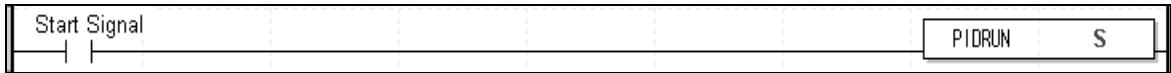

- Operand S means the loop no. to execute PID control and available only for constant(0~15).
- If start signal is on, the PID control of a loop starts.
- In case of IEC type, PID control is conducted by PIDRUN function block.
- In case of XGB IEC type, inputs '0' at BLOCK

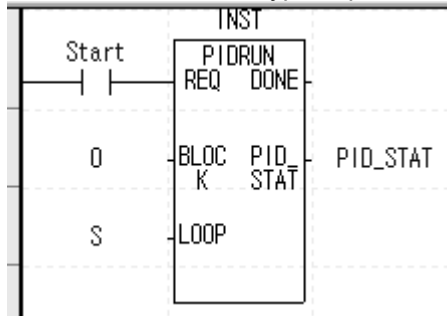

- PID\_STAT, only supported on IEC type, indicates status of PID operation. For meaning of indication data, refer to indication contents of PID STATE.

Indication contents of PID STATE

Item	Indication	Flag name	Contents
ALARM	16#0001	PV_MIN_MAX_ALM	Current value exceeds range of maximum, minimum value
	16#0002	PID_SCANTIME_ALM	Operation cycle is too short.
	16#0003	PID_dPV_WARN	Variation of current value of this PID cycle exceeds the current value variation limit.
	16#0004	PID_dMV_WARN	Variation of manipulated value of this PID cycle exceeds the manipulated value variation limit.
	16#0005	PID_MV_MAX_WARN	Manipulated value of this PID cycle exceeds maximum manipulated value.
	16#0006	PID_MV_MIN_WARN	Manipulated value of this PID cycle is smaller than minimum manipulated value.
ERROR	16#0100	MV_MIN_MAX_ERR	Maximum manipulated value is set to be smaller than minimum manipulated value.
	16#0200	PV_MIN_MAX_ERR	Maximum current value is set to be smaller than current manipulated value.
	16#0300	PWM_PERIOD_ERR	PWM output cycle is set to be smaller than 100(10ms).
	16#0400	SV_RANGE_ERR	In case of forward operation, set value at start of auto-tuning is smaller than current value. In case of reverse operation, set value at start of auto-tuning is larger than current value.
	16#0500	PWM_ADDRESS_ERR	PWM output is set as contact point other than %QX0.0.0~0.0.31.
	16#0600	P_GAIN_SET_ERR	Proportional constant is set to be smaller than 0.
	16#0700	I_TIME_SET_ERR	Integral constant is set to be smaller than 0
	16#0800	D_TIME_SET_ERR	Differential constant is set to be smaller than 0
	16#0900	CONTROL_MODE_ERR	Control mode is other than P, PI, PD and PID.
	16#0B00	PID_PERIOD_ERR;	PIC operation cycle is set to be smaller than 100(10ms)
	16#0C00	HBD_WRONG_DIR	In combined operation, directional parameter of forward operation loop is set as reverse operation or directional parameter of reverse operation loop is set as forward operation
	16#0D00	HBD_SV_NOT_MATCH	In combined operation, set values of two loops are different
	16#0E00	LOOP_EXCEED	PID LOOP number is larger 15

(2) PIDCAS

PIDCAS is a command to execute CASCADE control.

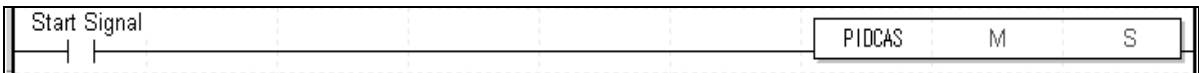

- Operand M and S mean master loop and slave loop respectively and available only for constant(0~15).
- If start junction is on, cascade control is executed through master loop and slave loop.
- In case of IEC type, PIDCAS function block is used for cascade control.

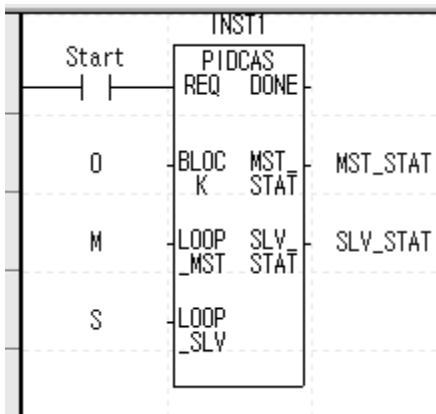

Cascade control is called a control method which is intended to increase control stability through quick removal of disturbance by connecting two PID control loops in series and is structured as follows.

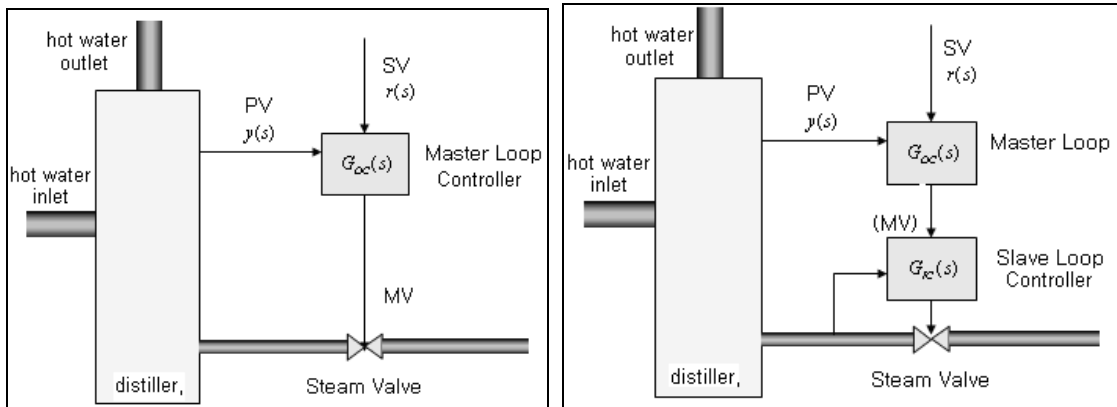

[Figure 15.13 Comparison of single loop control and cascade control]

Looking at the figure, it is found that cascade control contains slave loop control within external control loop. That is, the control output of external loop PID control is entered as SV of the internal loop control. Therefore, if steam valve suffers from disturbance in the figure, single loop PID control may not be modified until PV,  $y(s)$  appears while cascade control is structured to remove any disturbance by the internal PID loop control before any disturbance that occurs in its internal loop affects the PV,  $y(s)$ , so it can early remove the influence from disturbance.

XGB internal PID control connects two PID control loops each other, making cascade control possible. At the moment, MV of external loop is automatically entered as the SV of internal loop, so it is not necessary to enter it through program.

(3) PIDHBD

PIDHBD is a command to execute the mixed forward/reverse E control.

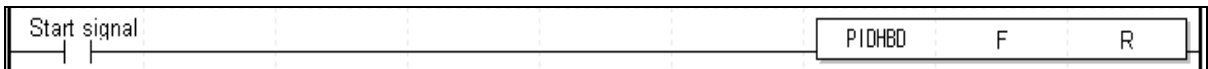

- Operand F and R represent forward operation loop and reverse operation loop and available only for constant(0~15).
- If start junction is on, it starts the mixed forward/reverse operation from the designated forward/reverse loops.
- In case of IEC type, combined operation is executed by using PIDHBD function block

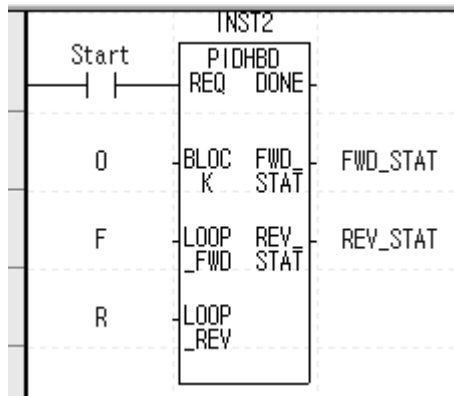

The mixed forward/reverse control is called a control method to control forward operation control output and reverse operation control operation alternatively to a single control process. The XGB built-in PID control enables the mixed forward/reverse control by connecting two PID control loops set as forward/reverse operations. At the moment, it uses PIDHBD command. For more information about the command, refer to 15.2.5. The mixed forward/reverse run is executed as follows in the XGB built-in PID control.

(a) Commencement of mixed run

If PIDHBC command starts first, it starts reverse run when PV is higher than SV; it starts forward run if PV is lower than SV.

(b) Conversion of RUN direction

The conversion of run direction is executed according to the following principles. In case of forward operation run, it keeps running by converting to reverse operation once PV is over SV + DeadBand value. At the moment, the DeadBand setting value uses the deadband of a loop set for forward operation. If PV is below SV – DeadBand value during reverse operation, it also keeps running by converting to forward operation. In the case, the DeadBand setting uses the deadband of a loop set for reverse loop. It may be illustrated as 15.14.



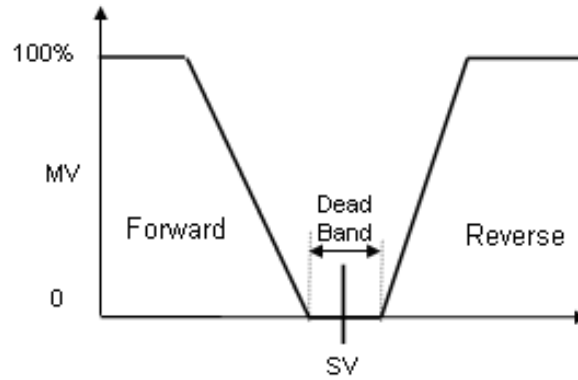

[Figure 15.14 Conversion of RUN direction in the mixed forward/reverse control]

(c) At the moment, every control parameter uses the parameter of a loop set for forward operation while MV is output to MV output area of a loop of forward operation. Reversely, every control parameter uses the parameter of a loop set for reverse operation during reverse operation run while MV is also output to MV output area of reverse operation loop.

(d) WRT

WRT is a command to save K area flags changed during operation to the internal flash memory of PLC.

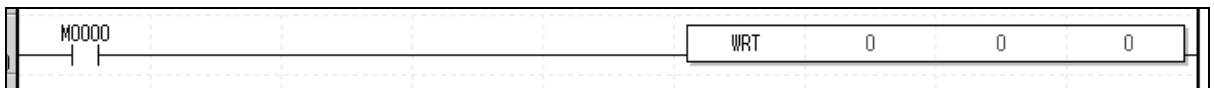

- Once start junction is on, it writes K area values to flash memory.
- Each operand description is summarized as follows.

Operand	Item designated	Available device	Remark
OP1	Slot	Constant	Designating basic unit as 0
OP2	N/A	P,M,L,K,D,Z,R, constant	Not used
OP3	Parameter type	P,M,L,K,D,Z,R,constant	0 : positioning X axis
			1 : positioning Y axis
			2 : HS counter
			3 : PID parameter
			4 : PID auto-tuning parameter

- In case of IEC type, APM\_WRT function block is used.

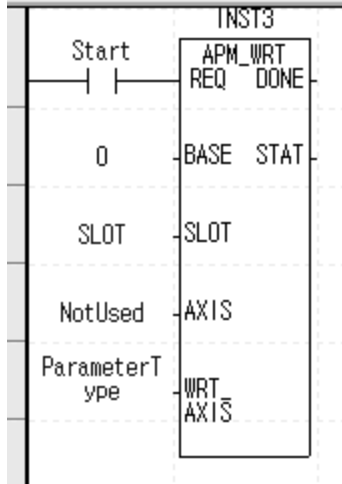

**15.4 PID Auto-tuning**

**15.4.1 Basic theory of PID auto-tuning**

It describes the function of PID auto-tuning.

The performance of PID controller is very different according to P, I, D coefficient. Generally, It is very difficult and takes long time to predict the system and set P, I, D coefficient because of non-periodical disturbance, interference of other control loop, dynamic characteristic of control system though the engineer is good at handling the PID controller. So auto-tuning that sets the PID coefficient automatically is very useful. Generally, there are many methods in setting the PID coefficient. Here, it will describe Relay Auto-tuning.

(1) PID coefficient setting by Relay auto-tuning

It makes critical oscillation by force and uses the width and period of oscillation to specify the PID coefficient. It applies max. output and min. output to control system for auto-tuning. Then, oscillation with steady period and steady width occurs around the Set value like figure 6.15, and it can calculate the boundary gain by using it like expression (15.3.1).

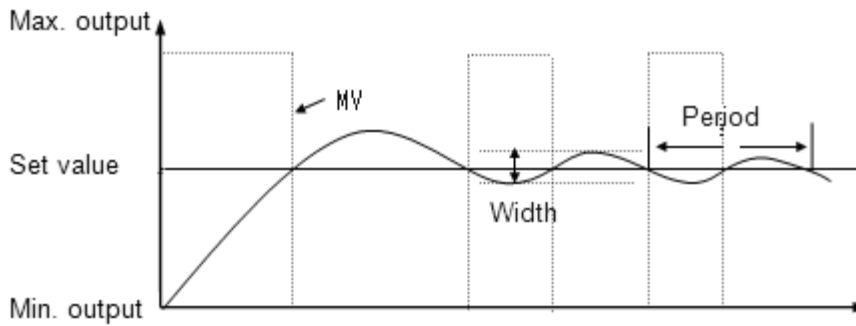

< Figure 15.15 Relay auto-tuning >

$$K_u = \frac{4 \times (\text{Max.output} - \text{Min.output})}{\pi \times \text{width}} \tag{15.4.1}$$

At this time, oscillation period is called boundary period. If boundary gain and period is specified, use table 15.9, Ziegler & Nichols tuning table to specify the PID coefficient. This Relay tuning is relatively simple to configure and easy to know the boundary gain and period so it is used frequently and XGB built-in PID auto-tuning uses this method.

Controller	Proportional gain (Kp)	Integral time(Ti)	Differential time(Td)
P	$0.5K_u$	-	-
PI	$0.45K_u$	$P_u / 1.2$	-
PID	$0.6K_u$	$P_u / 2$	$P_u / 8$

< Table 15.9 Ziegler & Nichols tuning table >

### 15.4.2 PID Auto-Tuning function specifications

The specifications of the XGB series built-in PID auto-tuning function are summarized as in Table.

Item		Specifications
Scope of SV		INT (-32,768 ~ 32,767)
Scope of PV		INT (-32,768 ~ 32,767)
Scope of MV		INT (-32,768 ~ 32,767)
Error indication		Normal: error flag off Error: error flag on, error code occurs
AT direction setting		Forward/Reverse
Control cycle		100 ~ 65,536 (0.1msUnit)
Additional function	PWM output	Supportable
	Hysteresis	Supportable

[Table 15.10 Spec. of built-in PID auto-tuning function]

### 15.4.3 Auto-tuning parameter setting

To use the XGB series auto-tuning function, it is necessary to start it by using a command after setting auto-tuning parameters by loops in the parameter window. It explains the parameters to use auto-tuning function and how to set them.

(1) Auto-tuning parameter setting

To set the parameters of XGB series auto-tuning function, follow the steps.

- (a) If selecting parameter in project window and the built-in parameter, it shows the built-in parameter setting window as seen in below figure.

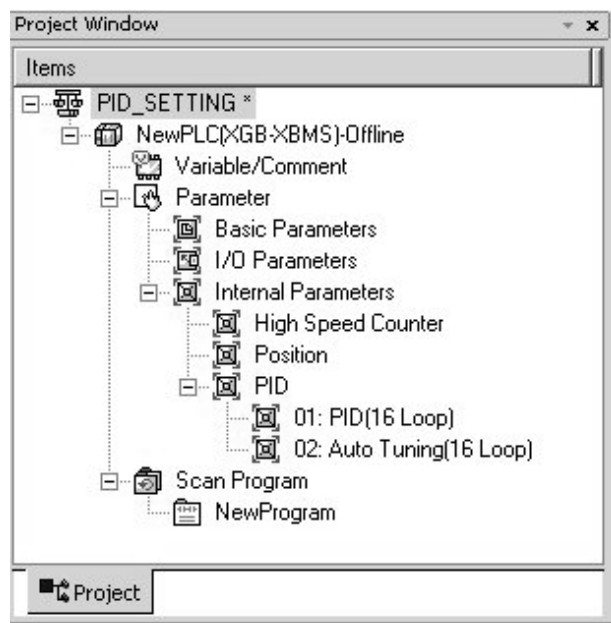

< Figure 15.16 Built-in parameter setting window >

(b) If selecting auto-tuning, it shows the parameter setting window as seen in Figure 15.17.

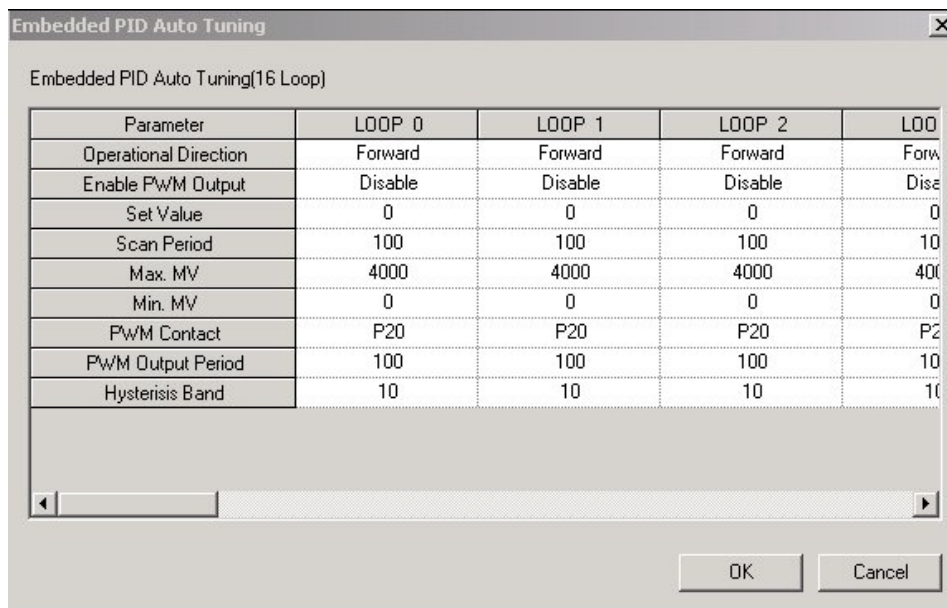

<Figure 15.17 Built-in auto-tuning function parameter setting window>

(c) Input items

Table shows the items to set in auto-tuning parameter window and the available scopes.

Items	Description	Scope
RUN direction	Set the run direction of auto-tuning.	Forward/reverse
PWM output enable	Set whether to set PWM output of MV enabled/disabled.	Disable/enable
SV	Set SV.	-32,768 ~ 32,767
Operation time	Set auto-tuning operation time.	100 ~ 65535
Max. MV	Set the max. MV in control.	-32,768 ~ 32,767
Min. mV	Set the min. MV in control.	-32,768 ~ 32,767
PWM junction designation	Designate the junction to which PWM output is output.	P20 ~ P3F
PWM output cycle	Set the output cycle of PWM output.	100 ~ 65,535
Hysteresis setting	Set the hysteresis of auto-tuning MV.	0 ~ 65,535

< Table 15.11 Auto-tuning function parameter setting items>

(2) Description of auto-tuning parameters and how to set them

(a) RUN direction

RUN direction is to set the direction of auto-tuning run of a loop. The available option is forward or reverse. The former (forward) means that PV increase when MV increases while the latter (reverse) means PV decreases when MV increases. For instance, a heater is a kind of forward direction system because PV (temperature) increases when output (heating) increases. A refrigerator is a kind of reverse direction system in which PV (temperature) decreases when output increases.

## (b) PWM output enable

PWM output means an output method to turn a junction on – off with a duty proportional to control output calculated by a uniform output cycle. If PWM output is enabled, it realizes PWM output in accordance with PWM output cycle set in the parameter of PWM output junction (P20 ~ P3F, in case of IEC type, %QX0.0.0~%QX0.0.15) designated in the parameter. At the moment, the PWM output cycle follows the PWM output cycle separately set in auto-tuning operation cycle.

## (c) SV

It sets the auto-tuning SV of a loop in question. Similar to PID control, physical values (temperature, flow rate, pressure and etc) of an object to control is not meaningful and instead, it should use the physical amount of an object to control after converting them into numerals. For instance, in order to control a system using a sensor that the output is 0V when its heating device temperature is 0°C while it is 10V when the temperature is 100°C as much as 50°C, it is necessary to set SV as 2000(as long as it uses AD input module XBE-AD04A).

## (d) Operation time

It sets the cycle to execute operation for auto-tuning. The setting cycle is 0.1ms and available between 10ms ~ 6553.5ms (setting value: 100 ~ 65,535) while it is set at a unit of integer per 0.1ms.

## (e) Max./min. MV

It sets the max./min. value of output for auto-tuning. The available scope is between -32,768 ~ 32,767. If the max. MV is set lower than min. MV, the auto-tuning function of a loop generates an error and does not work.

## (f) Hysteresis setting

Looking at relay tuning in Figure 15.15, it shows it outputs the max. MV as auto-tuning starts but it converts to min. output as PV is over SV and then, it converts to the max. output as PV is lower than SV. However, if input PV contains noise components or reply components, auto-tuning ends by a slight vibration of PV around SV, yielding incorrect tuning result. To prevent it, hysteresis may be set. XGB auto-tuning converts output at SV + Hysteresis when PV increases or at SV – Hysteresis when it decreases once hysteresis is set. With it, it may prevent incorrect tuning by a slight vibration around SV.

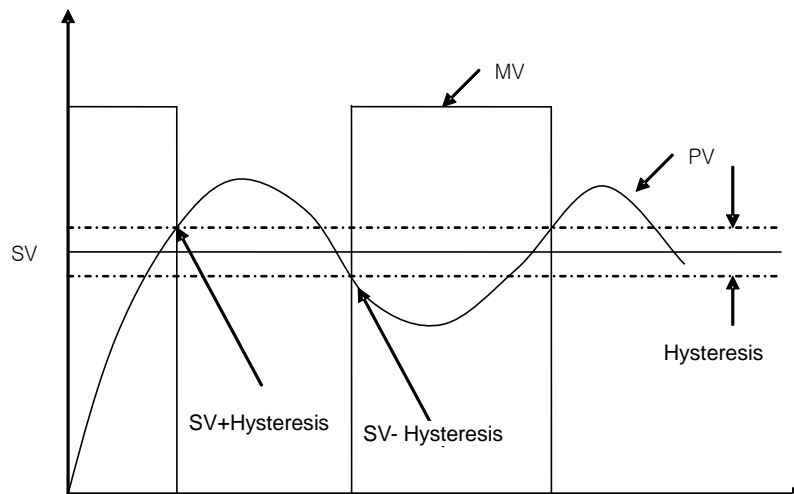

[Figure 15.16 Example of Hysteresis setting ]

### 15.4.4 Auto-tuning flag

The parameters set in the XGB series auto-tuning function are saved to the flash memory of basic unit. Such parameters are moved to K area for auto-tuning function as soon as PLC enters to RUN mode from STOP. Auto-tuning operation using auto-tuning command is achieved by data in K area. At the moment, if PLC is changed to RUN again after being changed to STOP, it takes the parameters in flash memory to K area, so the data changed in K area is lost. Therefore, to continuously apply the parameters adjusted in K area, it is necessary to write the parameters set in K area into flash memory by using WRT command. (In case of IEC type, APM\_WRT function block)

(1) Auto-tuning flag configuration

The K area flags of XGB series auto-tuning function are summarized in Table 15.12.

Loops	K area	IEC type	Symbol	Data type	Default	Description
Common	K18560~F	%KX29696 ~%KX29711	_AT_REV	Bit	Forward	Auto-tuning direction(0:forward, 1:reverse)
	K18570~F	%KX29712 ~%KX29727	_AT_PWM_EN	Bit	Disable	PWM output enable(0:disable, 1:enable)
	K18580~F	%KX29728 ~%KX29743	_AT_ERROR	Bit	-	Auto-tuning error(0:normal,1:error)
	K1859	%KW1859	Reserved	WORD	-	Reserved area
Loop0	K1860	%KW1860	_AT00_SV	INT	0	AT SV – loop 00
	K1861	%KW1861	_AT00_T_s	WORD	100	AT operation cycle (T_s)[0.1msec]
	K1862	%KW1862	_AT00_MV_max	INT	4000	AT MV max. value limit
	K1863	%KW1863	_AT00_MV_min	INT	0	AT MV min. value limit
	K1864	%KW1864	_AT00_PWM	WORD	0	AT PWM junction setting
	K1865	%KW1865	_AT00_PWM_Prd	WORD	0	AT PWM output cycle
	K1866	%KW1866	_AT00_HYS_val	WORD	0	AT hysteresis setting
	K1867	%KW1867	_AT00_STATUS	WORD	0	AT auto-tuning status indication
	K1868	%KW1868	_AT00_ERR_CODE	WORD	0	AT error code
	K1869	%KD	_AT00_K_p	REAL	0	AT result proportional coefficient
	K1871	-	_AT00_T_i	REAL	0	AT result integral time
	K1873	-	_AT00_T_d	REAL	0	AT result differential time
	K1875	-	_AT00_PV	INT	0	AT PV
	K1876	-	_AT00_MV	INT	0	AT MV
	K1877~1879	%KW1877 ~%KW1879	Reserved	Word	0	Reserved area

[Table 15.12 K area flags for auto-tuning]

K1856 ~ K1859 areas (In case of IEC type, %KW1856~%KW1859) are the common bit areas for auto-tuning and each bit represents auto-tuning loop status respectively. K1860~K1879 areas save the setting and status of loop 0 as the K area for auto-tuning loop 0. In the area, the parameters such as PV, operation cycle and etc set in the built-in parameter window are saved and the XGB built-in auto-tuning function executes auto-tuning by the device values and saves the results into the K areas.

(2) Auto-tuning flag function

Each function of K area flags for XGB series auto-tuning is summarized as follows.

A) Common bit area

The area is a flag collecting operation setting and information consisting of bits to each 16 loop. Each bit of each word device represents the information of each loop.

1) \_AT\_REV (auto-tuning run direction setting)

Flag name	Address	IEC type address	Unit	Setting
_AT_REV (PID RUN direction setting)	K1856n	%KX29696 + n	BIT	Available

It determines the run direction of auto-tuning of 'n' th loop. If the bit is off, it is forward operation; if on, it is reverse operation.

2) \_AT\_PWM\_EN (PWM output enable)

Flag name	Address	IEC type address	Unit	Setting
_AT_PWM_EN (PWM output enable)	K857n	%KX29713 + n	BIT	Available

It sets whether to output the auto-tuning MV of 'n' th loop as PWM output. If the bit is off, it is disabled; if on, it is enabled.

3) \_AT\_ERROR (Auto-tuning error occurrence)

Flag name	Address	IEC type address	Unit	Setting
_PID_ERROR (PID error occurrence)	K1858n	%KX29728 + n	BIT	Unavailable

It indicates the error in case an error that discontinues operation during auto-tuning of 'n'th loop occurs. If an error occurs, it is on; if normal, it is off. Once an error occurs, auto-tuning stops and the MV is output as the min. output set in the parameter. Also, if an error occurs, it indicates the error code in the error code area of a loop. For more information about error code types and measures, refer to 15.5. The area, as a dedicated monitor area, is updated although a user directly enters it.

B) Auto-tuning flag area by loops

The auto-tuning flag areas by loops are K1860 ~ K2179 and each 20 words per loop are allocated to totally 16 loops. Therefore, individual data area of 'n' th loop is between K (1860+16\*n) ~ K (1879+16\*n).

1) \_ATxx\_SV (auto-tuning xx Loop SV setting)

Flag name	Address	IEC type address	Unit	Scope
_ATxx_SV (AT xx Loop SV setting)	K1860+16*xx	%KW1860+16*xx	INT	-32,768 ~ 32,767

It sets/indicates the auto-tuning SV of 'xx'th loop. The available scope is between -32,768 ~ 32,767.



2) \_ATxx\_T\_s (Auto-tuning xx Loop operation cycle)

Flag name	Address	IEC type address	Unit	Scope
_PIDxx_T_s (Auto-tuning xx Loop operation cycle)	K1861+16*xx	%KW1861+16*xx	WORD	100 ~ 65,535

It sets/indicates the operation cycle of 'xx' th loop auto-tuning. The available scope is 100 ~ 65,535.

3) \_ATxx\_MV\_max, \_ATxx\_MV\_min(max. MV, min. MV)

Flag name	Address	IEC type address	Unit	Scope
_PIDxx_MV_max (Max. MV)	K1862+16*xx	%KW1862+16*xx	INT	-32,768 ~ 32,767
_PIDxx_MV_min (Min. MV)	K1863+16*xx	%KW1863+16*xx		

It sets max. MV and min. MV of 'xx' th loop respectively. If the max. MV is set lower than min. MV, the auto-tuning loop generates an error and does not work.

4) \_ATxx\_PWM (AT output junction setting)

Flag name	Address	IEC type address	Unit	Scope
_AT00_PWM (AT output junction setting)	K1864+16*xx	%KW1864+16*xx	WORD	H'20 ~ H'3F

It sets the junction that PWM output of 'xx' th loop is output. The PWM output junction is valid only between H'20 ~ H'3F (hex). If any other value is entered, PWM output does not work.

5) \_ATxx\_PWM\_Prd (PWM output cycle setting)

Flag name	Address	IEC type address	Unit	Scope
_ATxx_PWM_Prd (PWM output cycle setting)	K1865+16*xx	%KW1865+16*xx	WORD	100 ~ 65,535

It sets the PWM output cycle of 'xx' th loop. The available scope is between 100 ~ 65,535 at the unit of 0.1ms.

6) \_ATxx\_HYS\_val (Hysterisis setting)

Flag name	Address	IEC type address	Unit	Scope
_ATxx_HYS_val (Hysterisis setting)	K1866+16*xx	%KW1866+16*xx	WORD	0 ~ 65,535

It sets the hysteresis of 'xx' th loop. For more information about hysteresis function, refer to 6.3.3 Auto-Tuning Parameter Setting. If it is set as 0, it does not work.

7) \_ATxx\_STATUS (Auto-tuning status)

Flag name	Address	IEC type address	Unit	Scope
_ATxx_STATUS (Auto-tuning status)	K1867+16*xx	%KW1867+16*xx	WORD	Unavailable

It indicates the auto-tuning status of 'xx' th loop. If auto-tuning is in operation, it is 1; if completed, it is 128. In any other cases, it shows 0.

## 8) \_ATxx\_ERR\_CODE (Error code)

Flag name	Address	IEC type address	Unit	Scope
_ATxx_ERR_CODE (Error code)	K1868+16*xx	%KW1868+16*xx	WORD	Unavailable

It indicates error code in case an error occurs during the auto-tuning of 'xx'th loop. The flag, as a dedicated monitor, is updated although a user directly enters it. For more information about error code, refer to 15.5.

## 9) \_ATxx\_K\_p, \_ATxx\_T\_i, \_ATxx\_T\_d (AT result proportional coefficient, integral time, differential time)

Flag name	Address	IEC type address	Unit	Scope
_ATxx_K_p (proportional coefficient)	K1869+16*xx	%KD934+20*xx	Real	Unavailable
_ATxx_T_i (integral time)	K1871+16*xx	%KD1004+20*xx		
_ATxx_T_d (differential time)	K1873+16*xx	%K1005+20*xx		

The area indicates proportional coefficient, integral time and differential time calculated after the auto-tuning of 'xx' th loop is normally completed. The flag, as a dedicated monitoring, updated although a user directly enters it.

## 10) \_ATxx\_PV (PV)

Flag name	Address	IEC type address	Unit	Scope
_ATxx_PV (PV)	K1875+16*xx	%KW1875+16*xx	INT	-32,768 ~ 32,767

It is the area to receive PV of 'xx' th auto-tuning loop. PV is the present status of a system to control and in case of PID control, the entry from a sensor is saved into U device through input devices such as A/D input module and it moves the value to \_ATxx\_PV by using commands such as MOV every scanning, executing auto-tuning.

## 11) \_ATxx\_MV (Auto-tuning MV)

Flag name	Address	IEC type address	Unit	Scope
_ATxx_MV (auto-tuning MV)	K1876+16*xx	%KW1876+16*xx	INT	Unavailable

It is the area to output MV of 'xx' th auto-tuning loop. Every auto-tuning cycle, it saves XGB auto-tuning and it delivers the value in the area by using commands like MOV in a program and operates a drive every scanning.

### 15.4.5 Auto-tuning instructions

The commands used in XGB series auto-tuning are as follows.

1) PIDAT

PIDAT is a command to execute auto-tuning by loops.



- Operand S means the loop no. to execute auto-tuning and available only for constant(0~15).
- If start junction is on, the PID control of a loop starts.
- In case of IEC type, the following PIDAT function block is used for start of auto-tuning

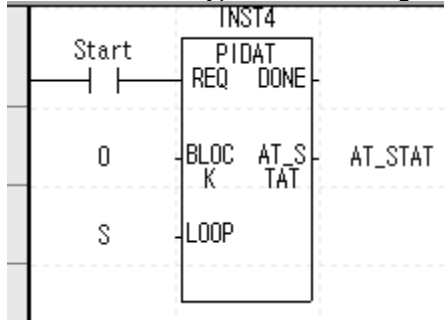

## 15.5 Example Programs

The paragraph explains example programs regarding the directions of XGB built-in PID function. The example programs are explained with water level system as illustrated in 15.17.

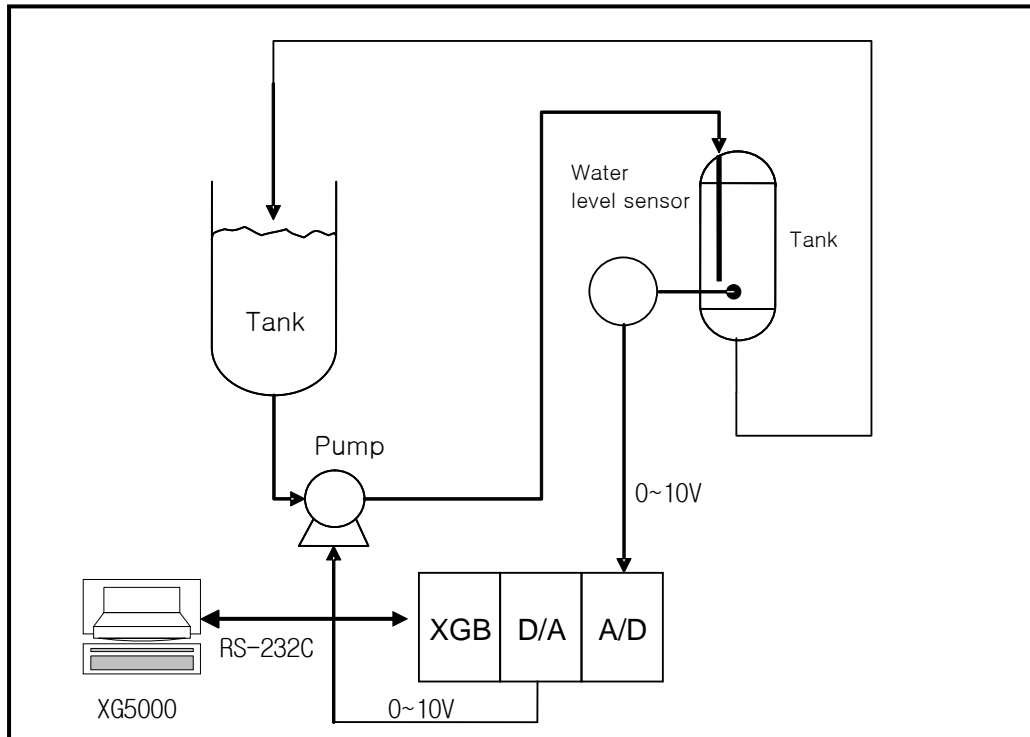

[ Figure 15.17 Example of water level control system ]

### 15.5.1 System structure

The example system in figure is an example of a system to control a pail's water level to a desired level. The pail's water level is sensed by a water level sensor and entered to A/D input module while PID control operation result, MV is output to a pump through D/A output module, controlling a pump's rotation velocity, regulating the water amount flowing into a pail and regulating the water level as desired. Each mechanism is explained as follows.

(1) XGB basic unit

The XGB basic unit operates by PID control operating PID control operation. It receives PV from A/D input module (XBF-AD04A), executes the built-in PID control operation, output the MV to D/A (XBF-DV04A) and executes PID control.

(2) A/D input module (XBF-AD04A)

It functions as receiving PV of an object to control from a water level sensor and delivering it to basic unit. XBF-AD04A is a 4CH analog input module and settings of analog input types and scopes can be changed in the I/O parameter setting window appeared when selecting I/O parameter in the parameter item of project window. For more information, refer to Analog I/O Module.

(3) D/A output module (XBF-DV04A)

It functions as delivering control MV from basic unit to a drive (pump). XBF-DV04A is a 4CH analog voltage output module and ranges 0 ~ 10V. For detail setting, refer to Analog I/O Module.

(4) Water Level Sensor

A water level sensor plays a role to deliver the PV of an object to control to XGB by measuring the water level of a pail and outputting it within 0 ~ 10V. Since the types and output scope of water level sensors varies, the output scope of a sensor should be identical with that of A/D input module's input scope. The example uses a water level sensor outputting between 0 ~ 10V.

(5) Drive (pump)

A drive uses a pump that receives control output of XGF-DV04A and of which rotation velocity is variable. For accurate PID control, the output scope of XBF-DV04A (0~10V) should be same with that of a pump's control input. The example uses a pump that receives its control input between 0 ~ 10V.

15.5.2. Example of PID Auto-tuning

Here, with examples, it explains how to calculate proportional constant, integral time and differential time by using PID auto-tuning function

(1) PID auto-tuning parameter setting

(a) If double-clicking Parameter – Built-in Parameter – PID – Auto-tuning parameter in the project window, it opens up the auto-tuning parameter setting window as illustrated in Figure 15.18.

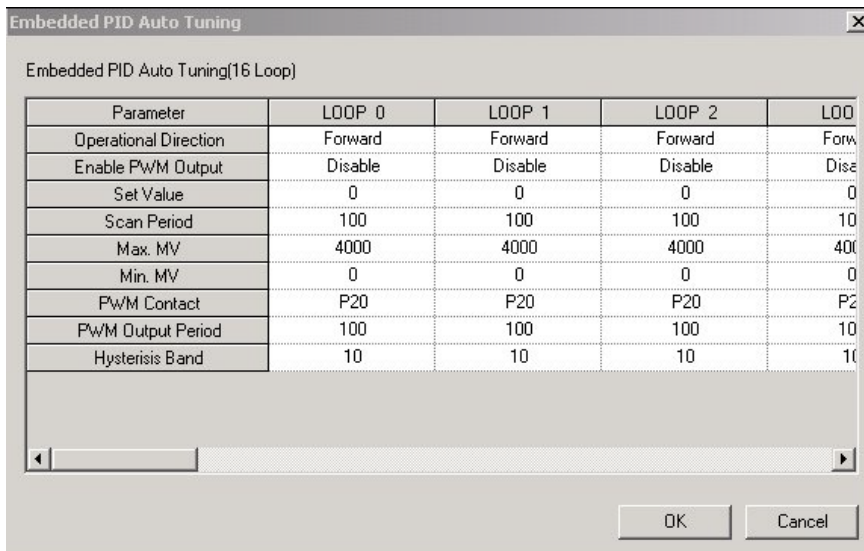

[Figure 15.18 Auto-tuning parameter setting window]

(b) Set each parameter and click OK.

In the example, Loop 0 is set as follows.

- RUN direction: forward
  - Since in the system, water level is going up as MV increases and pump's rotation velocity increases, it should be set as forward operation.
- PWM output: disabled
  - In the example, auto-tuning using PWM is not executed. Therefore, PWM output is set as disabled.
- SV: 1000(2.5V)
  - It shows an example in which XBF-AD04A is set as the voltage input of 0~10V.

- Max. MV: 4000
  - Max. MV is set as 4000. If MV is 4000, XBF-DV04A outputs 10V.
- Min. MV: 0
  - Min. MV is set as 0. If MV is 0, XBF-DV04A outputs 0V.
- PWM junction, PWM output cycle
  - It is not necessary to set it because the example does not use PWM output.
- Hysteresis setting: 10

(2) A/D input module parameter setting

(a) If double-clicking Parameter – I/O parameter, it opens up the setting window as illustrated in figure 15.19.

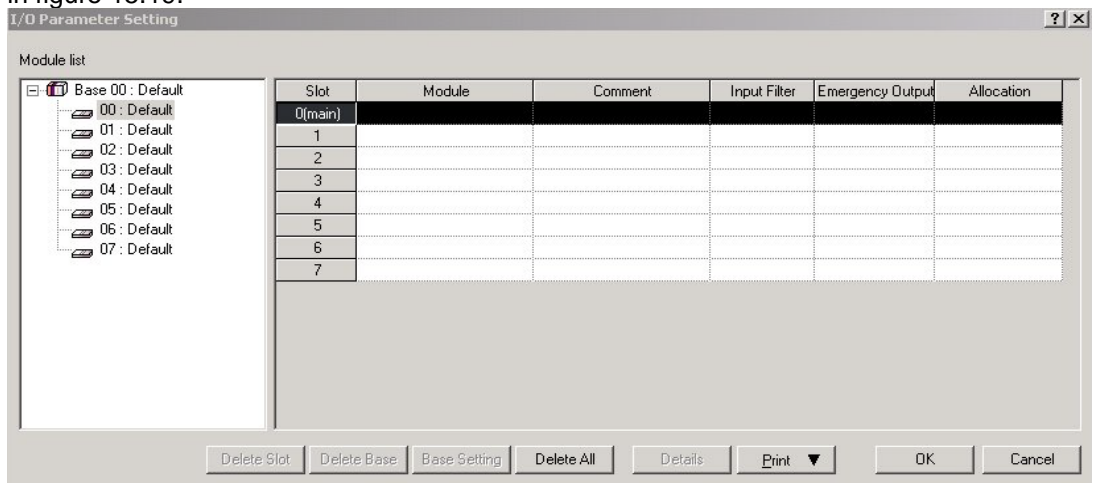

[ Figure 15.19 I/O parameter setting window ]

(b) If selecting A/D module for a slot in A/D input module, it opens up the setting window as illustrated in Figure 15.20.

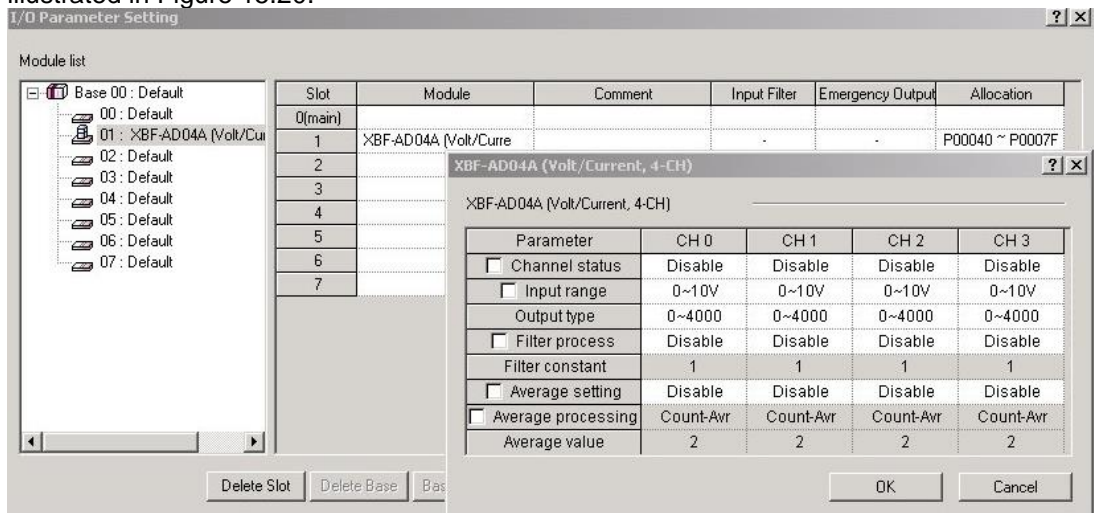

[ Figure 15.20 A/D input mode setting window ]

(c) Check A/D Module operation parameter and click OK. The example is set as follows.

- RUN CH: CH0 RUN
  - The example receives the water level sensor input as CH0.
- Input scope: 0 ~ 10V
  - Set XBF-AD04A input scope as 0 ~ 10V so that it should be identical with the output scope of water level sensor.

- Output data type: 0 ~ 4000
  - It converts the input 0 ~ 10V to digital value from 0 ~ 4000 and delivers it to basic unit.
  - In the case, the resolving power of digital value 1 is  $10/4000 = 2.5\text{mV}$
- Filter process, averaging: disabled
  - The example sets the input values in order that filter process and averaging are not available.
  - For more information about each function, refer to 12 Analog I/O Module.

(3) D/A Output Module Parameter setting

- (a) Set the parameter of D/A output module(XBF-DV04A) that output MV to a drive.  
How to set them is as same as A/D input module. In the example, it is set as follows.

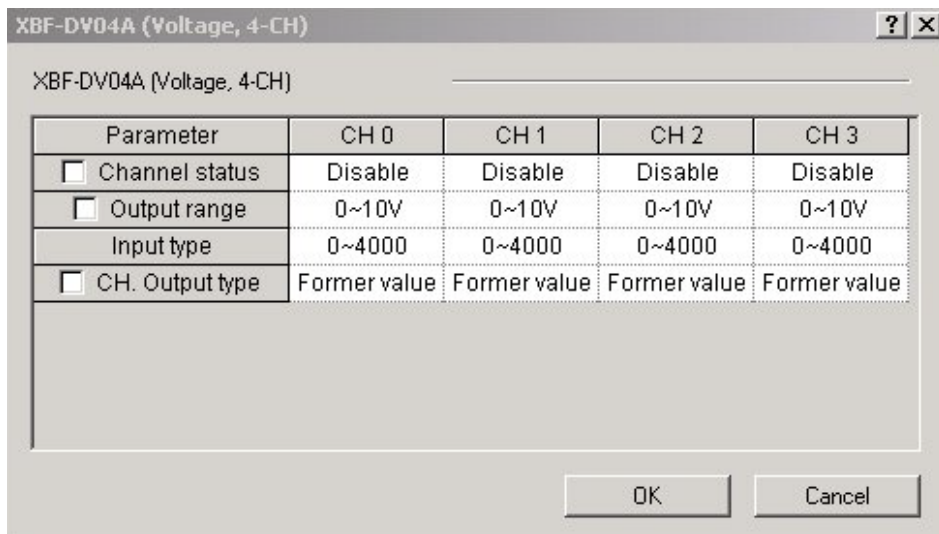

- RUN CH: CH0 RUN
  - In the example, MV is output as CH0 of D/A output module.
- Output scope : 0 ~ 10V
- Input data type: 0 ~ 4000

4) Example of PID Auto-tuning program

The example of PID auto-tuning program is illustrated as Figure 15.21.

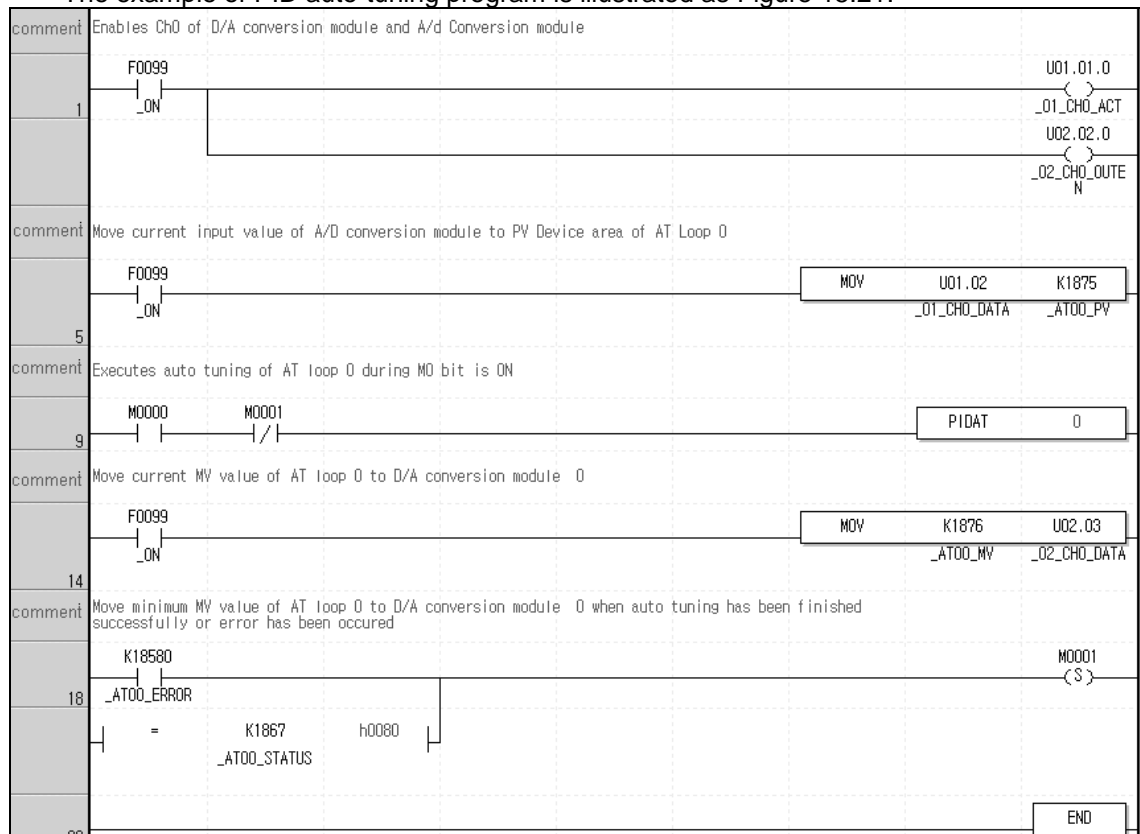

< Figure 15.21 Auto-tuning example program >

(a) Devices used

Device	Data type	Application
F0099	BIT	It is always on, so it readily operates once PLC is RUN.
U01.01.0	BIT	It starts operation of CH0 of Slot 1 A/D input module.
U02.02.0	BIT	It starts operation of CH0 of Slot 2 D/A output module.
U01.02	INT	PV entered to A/D input module.
U02.03	INT	MV entered to D/A output module.
K1875	INT	Device to which PV is entered for LOOP 0 auto-tuning
K1876	INT	Device to which auto-tuning MV of LOOP 0 is output.
K18677	BIT	Junction that is on once auto-tuning is complete.
K18580	BIT	Junction that is on once auto-tuning has an error.
K1863	INT	Min. MV of auto-tuning designated in parameter.

(b) Program explanation

- 1) Since F0099(always on) is ON if PLC is converted form STOP to RUN, CH0 of A/D and D/A starts operating.
- 2) At the moment, PV entered to CH0 is moved to K1875, the input device of PV and saved accordingly.
- 3) Once M0000 junction is on, the auto-tuning of loop 0 starts.
- 4) The auto-tuning MV of loop 0 that is output by PIDAT command is output to D/A output module by line 14 MOV command.
- 5) If auto-tuning is complete or there is any error during auto-tuning, M0001 junction is set, blocking operation of PIDAT command and it outputs min. MV set in parameter to D/A output module.



- (c) Monitoring and changing PID control variables using K area  
 In XGB series built-in auto-tuning, it can monitor and change RUN status of auto-tuning by using K area allocated as fixed area by loops.

1) Variable registration

If selecting “Register in Variable/Description” by right clicking in the variable monitor window, “Variable/Device Selection” window appears. Select “Item” as PID, deselect “View All” and enter 0(means loop number) in “Parameter No”, K area device list to save every setting and status of loop 0 appears as shown Figure 15.22. Then, if selecting a variable to monitor and clicking “OK”, a selected device is registered to variable monitor window as illustrated in Figure 15.23. Through the monitor window, a user can monitor auto-tuning run status or change the settings.

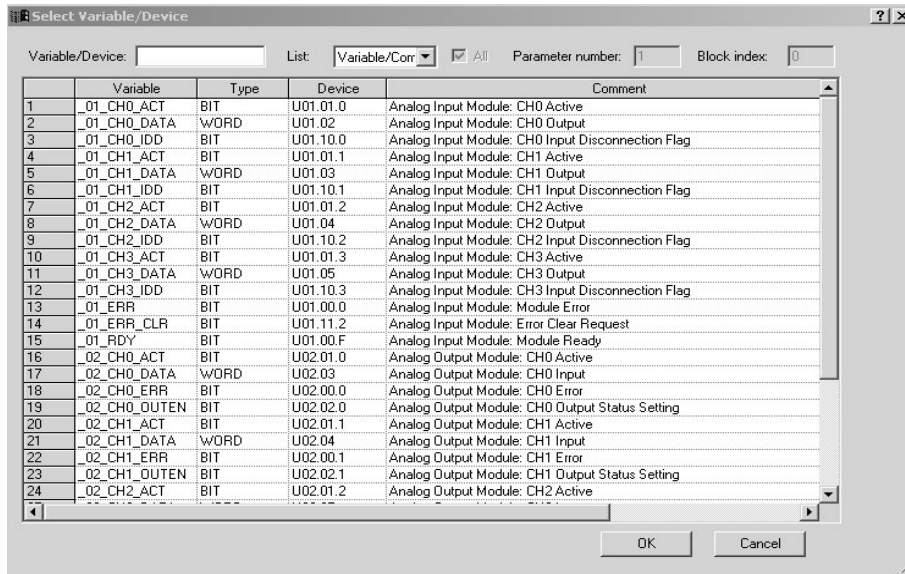

[Figure 15.22 Variable registration window]

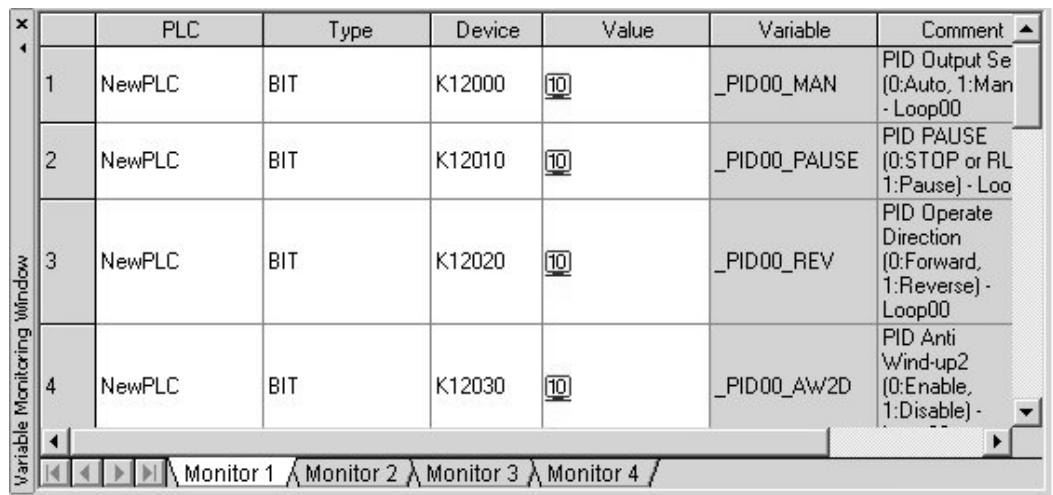

[Figure 15.23 Auto-tuning variables registered]

(d) In case of IEC type, example program  
 In case of IEC type, the following program is used.

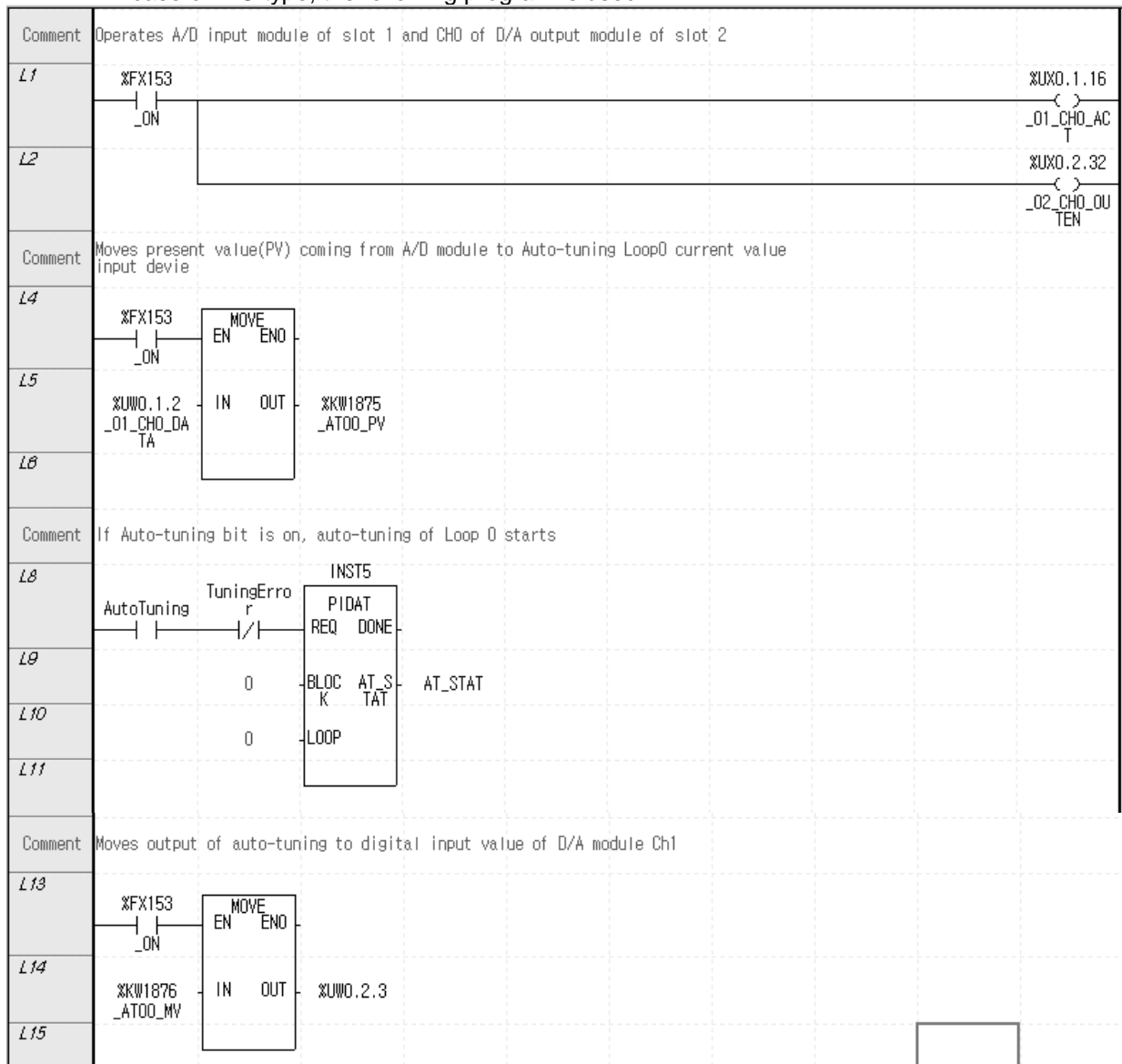

- (5) Observing RUN status by using trend monitor function  
 Since it is possible to monitor the operation status of XGB series built-in auto-tuning graphically, it is useful to monitor the operation status of auto-tuning clearly.
  - (a) If selecting Monitor – Trend monitor menu, it shows the trend monitor window as illustrated in Figure 15.24.

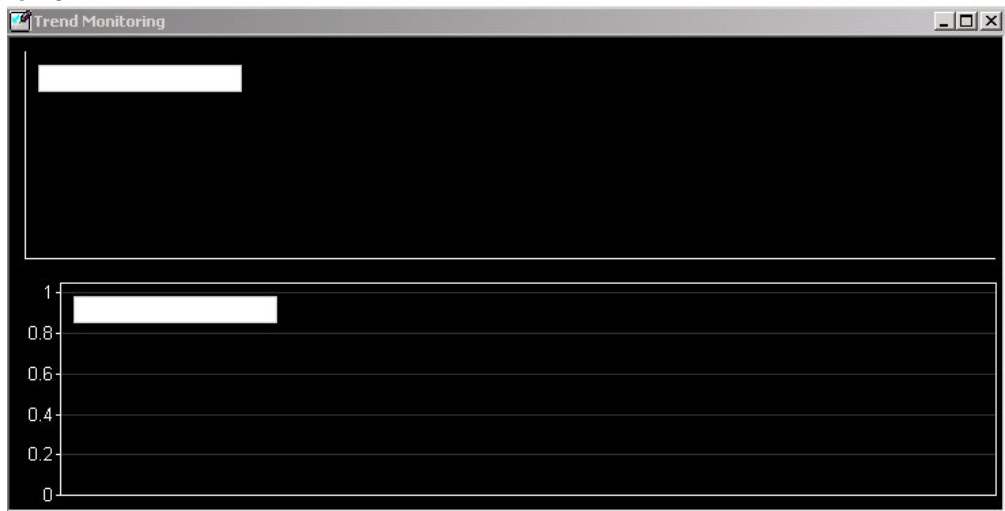

[ Figure 15.24 Trend Monitor window ]

- (b) If right-clicking trend setting, a user can select a variable to monitor as illustrated in Figure 15.25.

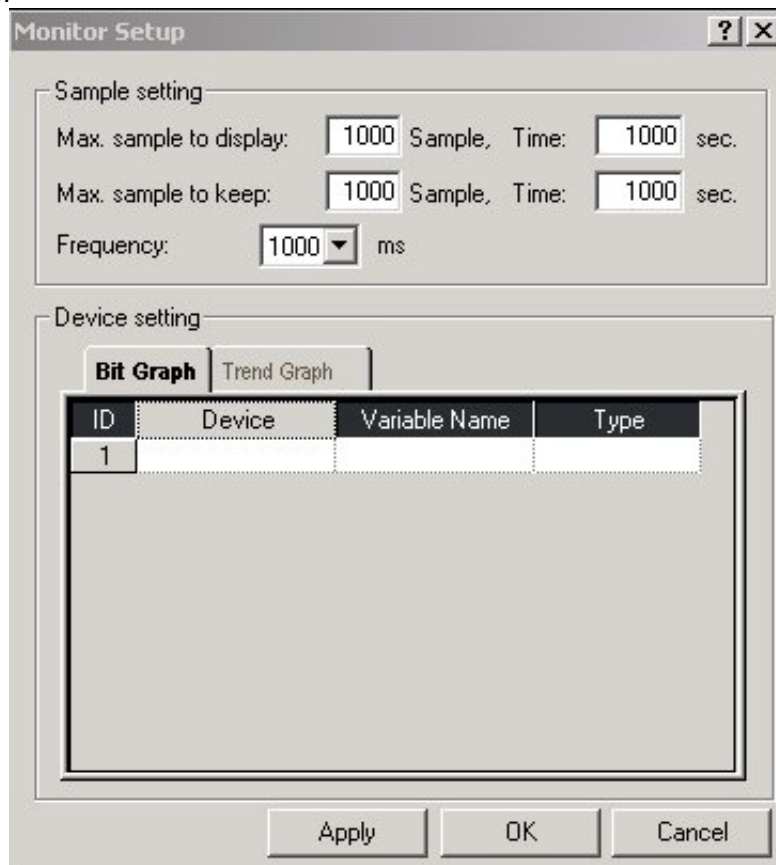

[ Figure 15.25 window to register trend monitor variable ]

- (c) For more information about trend monitor, refer to “XG5000 Use’s Manual.”

### 15.5.3. Stand-alone operation after PID Auto-Tuning

Here, with example, it explains how to execute PID control followed by PID auto-tuning.

(1) PID auto-tuning parameter setting

- PID auto-tuning parameters are set as same as examples of 15.4.2 Example of PID Auto-tuning.

(2) Setting parameters of A/D input module and D/A output module

- Set the parameters of A/D input module and D/A output module as same as the example in 15.4.2 Example of PID Auto-tuning.

(3) PID parameter setting

- (a) If double-clicking Parameter – Built-in Parameter – PID – PID Parameter, it shows the built-in PID parameter setting window as seen in Figure 15.26.

Parameter	LOOP 0	LOOP 1	LOOP 2	LOOP 3
Operational Mode	Auto Opr	Auto Opr	Auto Opr	Auto
Operational Direction	Forward	Forward	Forward	Forw
Secondary Anti windup	Disable	Disable	Disable	Dise
Derivative term Cal. Method	By Error	By Error	By Error	By E
Enable PWM Output	Disable	Disable	Disable	Dise
Set Value	0	0	0	0
Scan Period	100	100	100	100
Proportional Gain	1	1	1	1
Integral Time	0	0	0	0
Derivative Time	0	0	0	0
Delta PV Limit	0	0	0	0
Delta MV Limit	0	0	0	0
Max. MV	4000	4000	4000	4000
Min. MV	0	0	0	0
Manual MV	0	0	0	0
DeadBand Setting Value	0	0	0	0
Set filtering coefficient	0	0	0	0
PWM Contact	P20	P20	P20	P20
PWM Output Period	100	100	100	100
Set SV Ramp	0	0	0	0
Set PV Tracking	0	0	0	0
Min PV	0	0	0	0
Max PV	4000	4000	4000	4000

[ Figure 15.26 Auto-tuning parameter setting window ]

- (b) Set each parameter and click OK.

In the example, Loop 0 is set as follows.

- RUN mode: automatic
  - Set as automatic in order that PID control is executed as the built-in PID operation outputs MV.
- RUN direction: forward
  - Since in the system, water level is going up as MV increases and pump's rotation velocity increases, it should be set as forward operation.
- PWM Output: disabled
  - In the example, auto-tuning using PWM is not executed. Therefore, PWM output is set as disabled.

- SV: 1000(2.5V)
  - It shows an example in which XBF-AD04A is set as the voltage input of 0~10V
- Operation cycle: 1000
  - In the example, it is set that PID control is executed every 100ms.
- Proportional gain, integral time and differential time
  - It should be initially set as 1,0,0 because PID auto-tuning results is used with PID constant.
- Max. MV: 4000
  - Max. MV is set as 4000. If MV is 4000, XBF-DV04A outputs 10V.
- DeadBand: 0
  - It is set as 0 because the example does not use DeadBand function.
- Differential filter setting: 0
  - it is also set as 0 because the example does not use differential filter.
- Min. MV: 0
  - Min. MV is set as 0. If MV is 0, XBF-DV04A outputs 0V.
- PWM junction, PWM output cycle
  - It is not necessary to set them because the example does not use PWM output.
- SV ramp, PV follow-up: 0
  - It is not necessary to set SV ramp and PV follow-up because the example does not use them.
- Min. PV, Max. PV: 0
  - Set them as 0 and 4000 respectively so that it could be identical with A/D input module's input scope.

(c) Example of PID control program after PID auto-tuning  
 The program example for PID auto-tuning is illustrated as Figure 15.27.

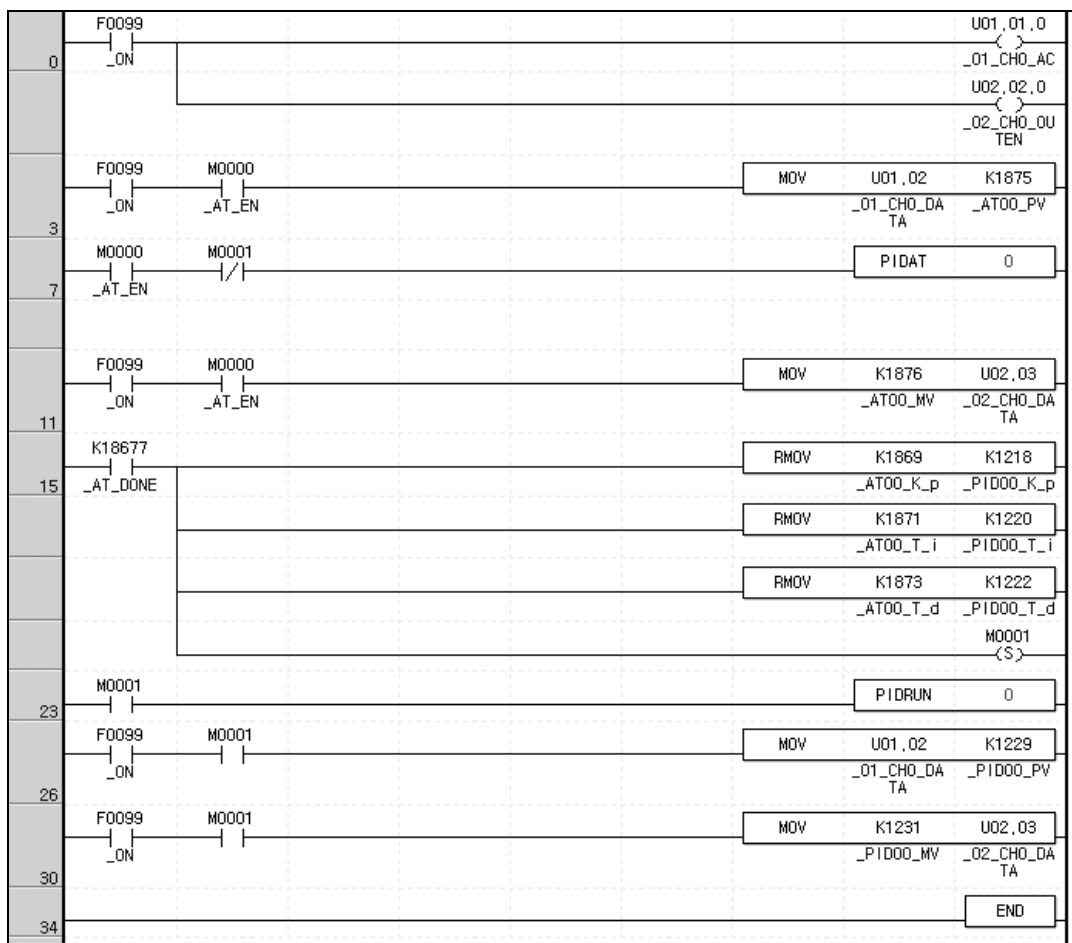

[Figure 15.27 Example program of PID control after auto-tuning]

1) Devices used

Device	Data type	Application
F0099	BIT	It is always on, so it readily operates once PLC is RUN.
U01.01.0	BIT	It starts operation of CH0 of Slot 1 A/D input module.
U02.02.0	BIT	It starts operation of CH0 of Slot 2 D/A output module.
U01.02	INT	PV entered to A/D input module.
U02.03	INT	MV entered to D/A output module.
K1875	INT	Device to which PV is entered for LOOP 0 auto-tuning
K1876	INT	Device to which auto-tuning MV of LOOP 0 is output.
K18677	BIT	Junction that is on once auto-tuning is complete.
K18580	BIT	Junction that is on once auto-tuning has an error.
K1863	INT	Min. MV of auto-tuning designated in parameter.
K1229	INT	Device to which PV is entered for Loop 0 PID control
K1876	INT	Device to which MV of loop 0 PID control is output.

2) Program explanation

- a) Since F0099 (always on) is ON if PLC is converted from STOP to RUN, CH0 of A/D and D/A starts operating.
- b) Once M0000 junction is on, the auto-tuning of loop 0 starts. At the moment, PV entered to CH0 is moved to K1875, the PV input device of loop 0 and saved accordingly.
- c) The auto-tuning MV of Loop 0 output by PIDAT command is output to D/A output module by line 11, MOV command.
- d) Once auto-tuning is complete, it moves P, I, D coefficients generated from auto-tuning to the input devices of P, I and D, K1218, K1220 and K1222, sets M001 and starts the operation of PID loop 0.

3) In case of IEC type, program example is as shown below.

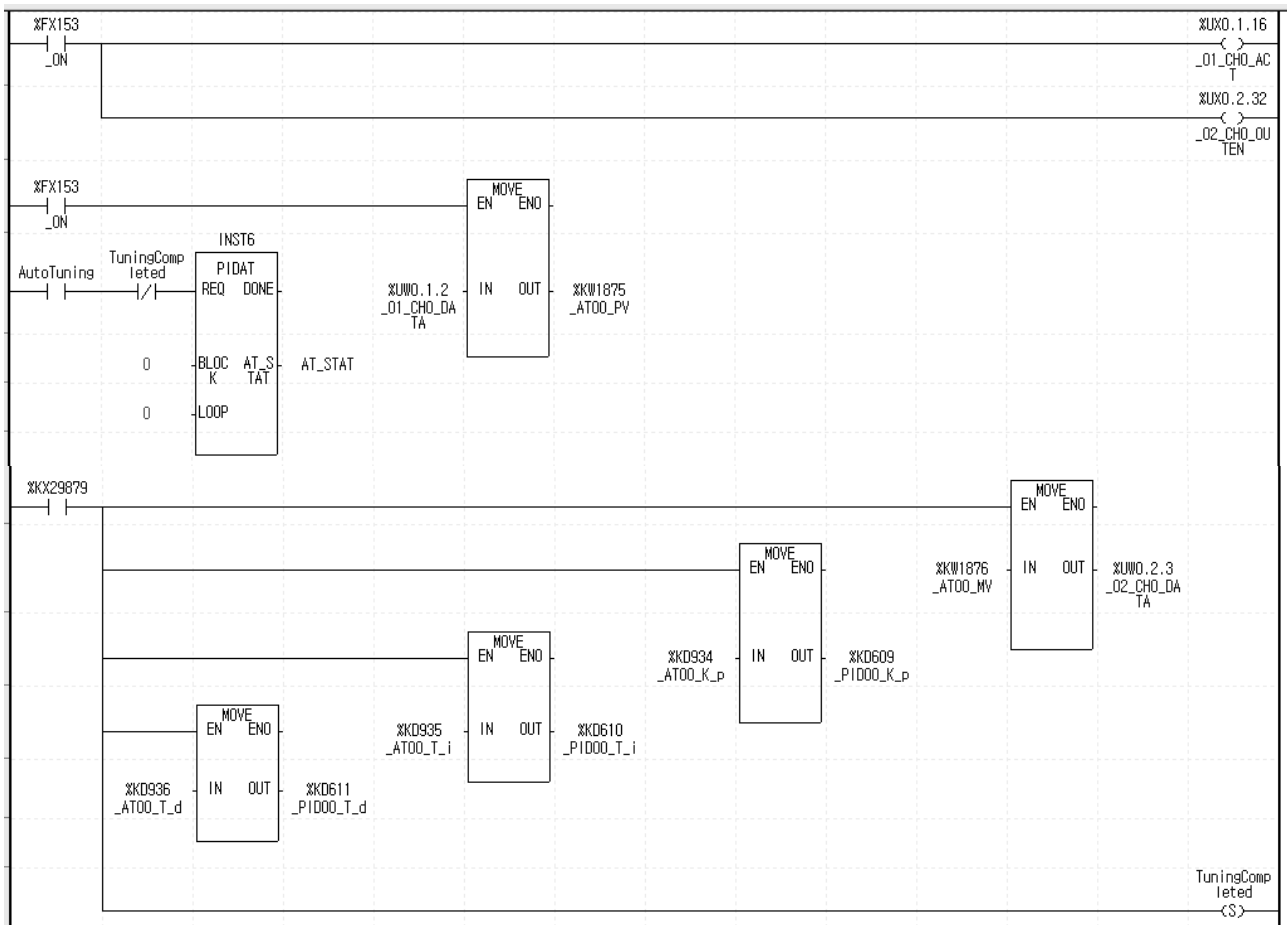

## 15.6 Error/Warning Codes

It describes error codes and warning codes of the XGB built-in PID function. The error codes and warning codes that may occur during use of the XGB built-in PID function are summarized as table. If any error or warning occurs, remove potential causes of the error by referring to the tables.

### 15.6.1. Error codes

Error codes	Indications	Measures
H'0001	MV_MIN_MAX_ERR	It occurs when max. MV is set lower than min. MV. Make sure to set max. MV larger than min. MV.
H'0002	PV_MIN_MAX_ERR	It occurs when max. PV is set lower min. Pv. Make sure to set max. PV larger than min. PV.
H'0003	PWM_PERIOD_ERR	It occurs when the period of auto tuning or PID operation loop is set under 100(10ms). Make sure to set output period more than 100.
H'0004	SV_RANGE_ERR	It occurs when SV is larger than PV at the start time of auto-tuning if auto-tuning is forward or when SV is larger than PV at the start time of auto-tuning if auto-tuning is reverse.
H'0005	PWM_ADDRESS_ERR	It occurs when the junction designated as PWM output junction is beyond between P20 ~ P3F.
H'0006	P_GAIN_SET_ERR	It occurs when proportional constant is set lower than 0.
H'0007	I_TIME_SET_ERR	It occurs when integral time is set lower than 0.
H'0008	D_TIME_SET_ERR	It occurs when differential time is set lower than 0.
H'0009	CONTROL_MODE_ERR	It occurs when control mode is not P, PI, PD or PID.
H'000A	TUNE_DIR_CHG_ERR	It occurs when operation direction is changed during auto-tuning. Never attempt to change operation direction during auto-tuning.
H000B	PID_PERIOD_ERR	It occurs when period of operation is smaller than 100 (10ms) at Auto-tuning or PID operation. Make sure to set period of operation larger than 100.
H000C	HBD_WRONG_DIR	In mixed operation, It occurs when the direction parameter of forward operation set to reverse operation or the direction parameter of reverse operation set to forward operation. Make sure set to appropriate direction each loop.
H000D	HBD_SV_NOT_MATCH	In mixed operation, it occurs when the Set value of each loop is not concurrent. Make sure set to Set value concurrently.

[Table 15.13 : PID error codes]



15.6.2. Warning codes

Error codes	Indications	Measures
H'0001	PV_MIN_MAX_ALM	It occurs when the set PV is beyond the min./max. PV.
H'0002	PID_SCANTIME_ALM	It occurs when PID operation cycle is too short. It is desirable to set PID operation cycle longer than PLC scan time.
H'0003	PID_dPV_WARN	It occurs when the PV change of PID cycle exceeds PV change limit.
H'0004	PID_dMV_WARN	It occurs when the PV cycle MV change exceeds MV change limit.
H'0005	PID_MV_MAX_WARN	It occurs when the calculated MV of PID cycle exceeds the max. MV.
H'0006	PID_MV_MIN_WARN	It occurs when the calculated MV of PID cycle is smaller than the min. MV

[Table 15.14 : PID error codes]

**Appendix 1 Standard Resistor of RTD General**

Pt100Ω										
-200	18.52									
-100	60.26	56.19	52.11	48.00	43.88	39.72	35.54	31.34	27.10	22.83
0	100.00	96.09	92.55	88.22	84.27	80.31	76.33	72.33	68.33	64.30
Temp.(°C)	0	10	20	30	40	50	60	70	80	90
0	100.00	103.90	107.79	111.67	115.54	119.40	123.24	127.08	130.90	134.71
100	138.51	142.29	146.07	149.83	153.58	157.33	161.05	164.77	168.48	172.17
200	175.86	179.53	183.19	186.84	190.47	194.10	197.71	201.31	204.90	208.48
300	212.05	215.61	219.86	222.68	226.21	229.72	233.21	236.70	240.18	243.64
400	247.09	250.53	253.96	257.38	260.78	264.18	267.56	270.93	274.29	277.64
500	280.98	284.30	287.62	290.92	294.21	297.49	300.75	304.01	307.25	310.49
600	313.71									
JPt100Ω										
-200	17.14									
-100	59.57	55.44	51.29	47.11	42.91	38.68	34.42	30.12	25.80	21.46
0	100.00	96.02	92.02	88.01	83.99	79.96	75.91	71.85	67.77	63.68
Temp.(°C)	0	10	20	30	40	50	60	70	80	90
0	100.00	103.97	107.93	111.88	115.81	119.73	123.64	127.54	131.42	135.3
100	139.16	143.01	146.85	150.67	154.49	158.29	162.08	165.86	169.63	173.38
200	177.13	180.86	184.58	188.29	191.99	195.67	199.35	203.01	206.66	210.3
300	213.93	217.51	221.15	224.74	228.32	231.89	235.45	238.99	242.53	246.05
400	249.56	253.06	256.55	260.02	263.49	266.94	270.38	273.8	277.22	280.63
500	284.02	287.4	290.77	294.12	297.47	300.8	304.12	307.43	310.72	314.01
600	317.28									



## Appendix 2 Thermo Electromotive Force and Compensating Cab

### 2.1 Table of Thermo Electromotive Force

unit:  $\mu V$

► Type K

-200	-100	-0	Temp. (°C)	Temp. (°C)	0	100	200	300	400	500	600	700	800	900	1000	1100	1200
-5891	-3553	-0	-0	0	0	4095	8137	12207	16395	20640	24902	29128	33277	37325	41269	45108	48828
	-3852	-392	-10	10	397	4508	8537	12623	16818	21066	25327	29547	33686	37724	41657	45486	
	-4138	-777	-20	20	798	4919	8938	13039	17241	21493	25751	29965	34095	38122	42045	45863	
	-4410	-1156	-30	30	1203	5327	9341	13456	17664	21919	26176	30383	34502	38519	42432	46238	
	-4669	-1527	-40	40	1611	5733	9745	13874	18088	22346	26599	30799	34909	38915	42817	46612	
	-4912	-1889	-50	50	2022	6137	10151	14292	18513	22772	27022	31214	35314	39310	43202	46985	
	-5141	-2243	-60	60	2436	6539	10560	14712	18938	23198	27445	31629	35718	39703	43585	47356	
	-5354	-2586	-70	70	2850	6939	10969	15132	19363	23624	27867	32042	36121	40096	43968	47726	
	-5550	-2920	-80	80	3266	7338	11381	15552	19788	24050	28288	32455	36524	40488	44349	48095	
	-5730	-3242	-90	90	3681	7737	11793	15974	20214	24476	28709	32866	36925	40879	44729	48462	

► Type J

unit:  $\mu V$

-200	-100	-0	Temp. (°C)	Temp. (°C)	0	100	200	300	400	500	600	700	800
-7890	-4632	0	-0	0	0	5268	10777	16325	21846	27388	33096	39130	45498
	-5036	-501	-10	10	507	5812	11332	16879	22397	27949	33683	39754	
	-5426	-995	-20	20	1019	6359	11887	17432	22949	28511	34273	40382	
	-5801	-1481	-30	30	1536	6907	12442	17984	23501	29075	34867	41013	
	-6159	-1960	-40	40	2058	7457	12998	18537	24054	29642	35464	41647	
	-6499	-2431	-50	50	2585	8008	13553	19089	24607	30210	36066	42283	
	-6821	-2892	-60	60	3115	8560	14108	19640	25161	30782	36671	42922	
	-7122	-3344	-70	70	3649	9113	14663	20192	25716	31356	37280	43563	
	-7402	-3785	-80	80	4186	9667	15217	20743	26272	31933	37893	44207	
	-7659	-4215	-90	90	4725	10222	15771	21295	26829	32513	38510	44852	

## Appendix2 Thermo Electromotive Force and Compensating Cable

▶ Type T

unit:  $\mu V$

-200	-100	-0	( $^{\circ}C$ )	( $^{\circ}C$ )	0	100	200	300	400
-5603	-3378	0	-0	0	0	4277	9286	14860	20869
	-3656	-383	-10	10	391	4749	9820	15443	
	-3923	-757	-20	20	789	5227	10360	16030	
	-4177	-1121	-30	30	1196	5712	10905	16621	
	-4419	-1475	-40	40	1611	6204	11456	17217	
	-4648	-1819	-50	50	2035	6702	12011	17816	
	-4865	-2152	-60	60	2467	7207	12572	18420	
	-5069	-2475	-70	70	2908	7718	13137	19027	
	-5261	-2788	-80	80	3357	8235	13707	19638	
	-5439	-3089	-90	90	3813	8757	14281	20252	

▶ Type R

unit:  $\mu V$

( $^{\circ}C$ )	0	100	200	300	400	500	600	700	800	900	1000	1100	1200	1300	1400	1500	1600	1700
0	0	647	1468	2400	3407	4471	5582	6741	7949	9203	10503	11846	13224	14624	16035	17445	18842	20215
10	54	723	1557	2498	3511	4580	5696	6860	8072	9331	10636	11983	13363	14765	16176	17585	18981	20350
20	111	800	1647	2596	3616	4689	5810	6979	8196	9460	10768	12119	13502	14906	16317	17726	19119	20483
30	171	879	1738	2695	3721	4799	5925	7098	8320	9589	10902	12257	13642	15047	16458	17866	19257	20616
40	232	959	1830	2795	3826	4910	6040	7218	8445	9718	11035	12394	13782	15188	16599	18006	19395	20748
50	296	1041	1923	2896	3933	5021	6155	7339	8570	9848	11170	12532	13922	15329	16741	18146	19533	20878
60	363	1124	2017	2997	4039	5132	6272	7460	8696	9978	11304	12669	14062	15470	16882	18286	19670	21006
70	431	1208	2111	3099	4146	5244	6388	7582	8822	10109	11439	12808	14202	15611	17022	18425	19807	
80	501	1294	2207	3201	4254	5356	6505	7704	8949	10240	11574	12946	14343	15752	17163	18564	19944	
90	573	1380	2303	3304	4362	5469	6623	7826	9076	10371	11710	13085	14483	15893	17304	18703	20080	

## 2.2 Thermocouple

### 2.2.1 Common limit and overheat limit

Symbol of materials	Former symbols (cf)	Nominal diameter (mm)	Common limit (1) °C	Overheat limit (2) °C
K	CA	0.65	650	850
		1.00	750	950
		1.60	850	1050
		2.30	900	1100
		3.20	1000	1200
J	IC	0.65	400	500
		1.00	450	550
		1.60	500	650
		2.30	550	750
		3.20	600	750
T	CC	0.32	200	250
		0.65	200	250
		1.00	250	300
		1.60	300	300
R	-	0.50	1400	1600

#### Remarks

- (1): common limit refers to the temperature limit that continuously use in the air.  
 (2): overheat limit refers to the temperature limit that may inevitably use for a short time.

**2.2.2 Allowance by temperature**

Symbol of materials	Former symbols (cf)	Temperature	Grade	Allowance
K	CA	0 °C ~ lower than 1000°C	0.4	±1.5°C or ±0.4% of temperature measured
		0°C ~ lower than 1200°C	0.75	±2.5°C or ±0.75% of temperature measured
		-200°C~ lower than 0°C	1.5	±2.5°C or ±1.5% of temperature measured
J	IC	0°C~ lower than 750°C	0.4	±1.5 °C or ±0.4% of temperature measured
		0°C~ lower than 750°C	0.75	±2.5°C or ±0.75% of temperature measured
T	CC	0°C~ lower than 350°C	0.4	±0.5°C or ±0.4% of temperature measured
		0°C~ lower than 350°C	0.75	±1°C or ±0.75% of temperature measured
		-200°C~ lower than 0°C	1.5	±1°C or ± 1.5% of temperature measured
R	-	0 °C ~ lower than 1600°C	0.25	±1.5 °C or ±0.25% of temperature measured

<b>Remark</b>
Allowance refers to the allowable max. limit subtracting the actual temperature of junction from the converted temperature, based on thermo electromotive force table. In addition, the allowance will be bigger one of °C or %.

## 2.3 Compensating Cable

### 2.3.1 Type and specifications of compensating cable

Type of compound thermocouple		Type of compensating type		Sectional ratio by application and allowance	Materials		Operating temp. range (°C)	Temp. of thermo. and junction (°C)	Electric resistance of compensating cable (Ω) <sup>(2)</sup>	Electric resistance of return cable (Ω) <sup>(2)</sup>	Sheath colors	Core cables color		Remarks	
Symbol	Former symbol	symbol	Former symbol		+ point	- point						+	-		
K	CA	KX-G	WCA-G	Common for general use	Alloy of nickel and chrome	Alloy of nickel	-20~90	-20~150	±2.5	1.5	Blue	Red	White		
		KX-GS	WCA-GS	Common for general use			±1.5								
		KX-H	WCA-H	Common for heat-resistance			0~150		±2.5						
		KX-HS	WCA-HS	Common for heat-resistance			±1.5								
		WX-G	WCA-G	Common for general use	Iron	Alloy of copper and nickel	-20~90		±3.0	0.5					
		WX-H	WCA-H	Common for heat-resistance			0~150								
		VX-G	WCA-G	Common for general use	Copper	Alloy of copper and nickel	-20~90		-20~100	0.8					
J	IC	JX-G	WIC-G	Common for general use	Iron	Alloy of copper and nickel	-20~90	-20~150	±2.5	0.8	Yellow	Red	White		
		JX-H	WIC-H	Common for heat-resistance			0~150								
T	CC	TX-G	WCC-C	Common for general use	Copper	Alloy of copper and nickel	-20~90		±2.0	0.8	Brown	Red	White		
		TX-GS	-	Precise for general use			±1.0								
		TX-H	WCC-H	Common for heat-resistance			0~150		±2.0						
		TX-HS	-	Precise for heat-resistance			±1.0								
R	-	Rx-G	-	Common for general use	Copper	Alloy of copper and nickel	0~90		0~150	+3 <sup>(1)</sup>	0.1	Black	Red		White
		RX-H	-	Common for heat-resistance			0~150	-7							

#### Remark

- (1) The thermocouple electromotive force of thermocouple R and S is non-linear, so it does not indicate the actual temperature measurement error.
- (2) Applicable to nominal cross-sectional area of 1.25mm<sup>2</sup> and more.





Appendix 3 Dimension

1) Dimension of XBF-AD04A

Unit: mm

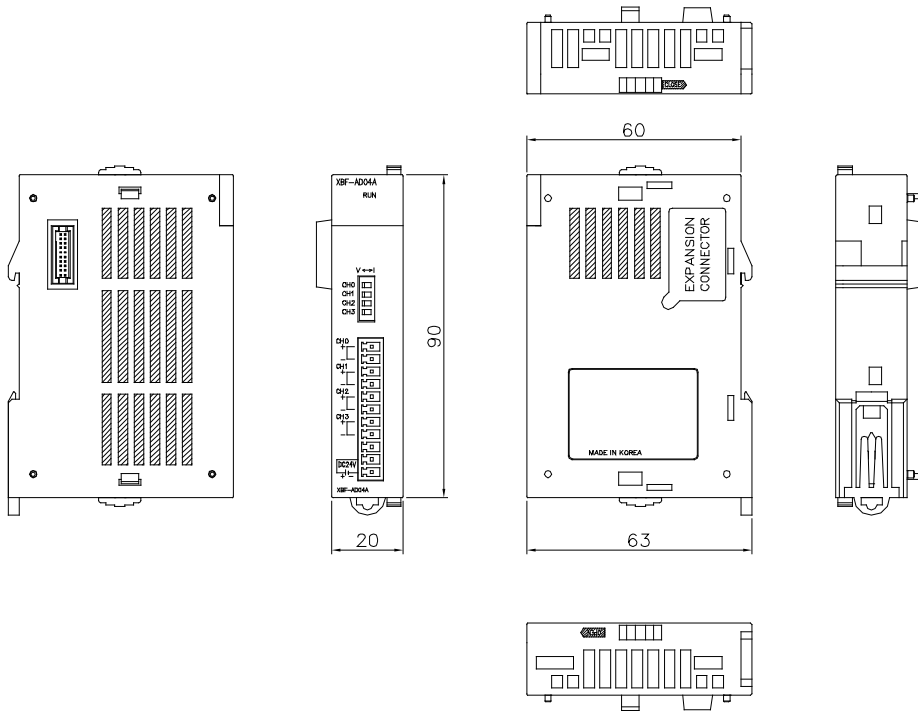

2) Dimension of XBF-DV04A / DV04C

Unit: mm

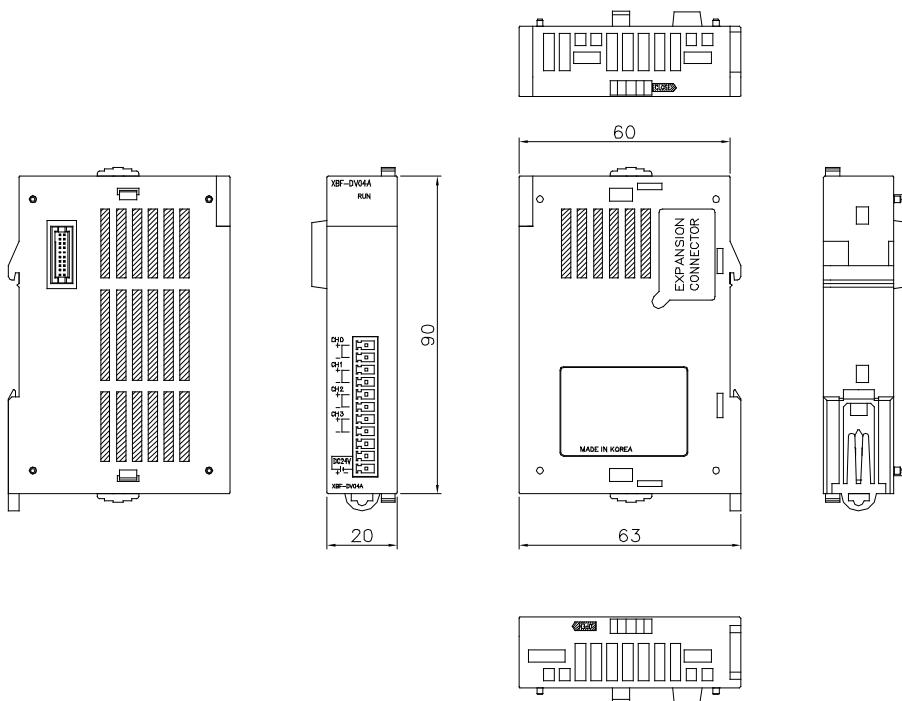

3) Dimension of XBF-DC04A / DC04B / DC04C

Unit: mm

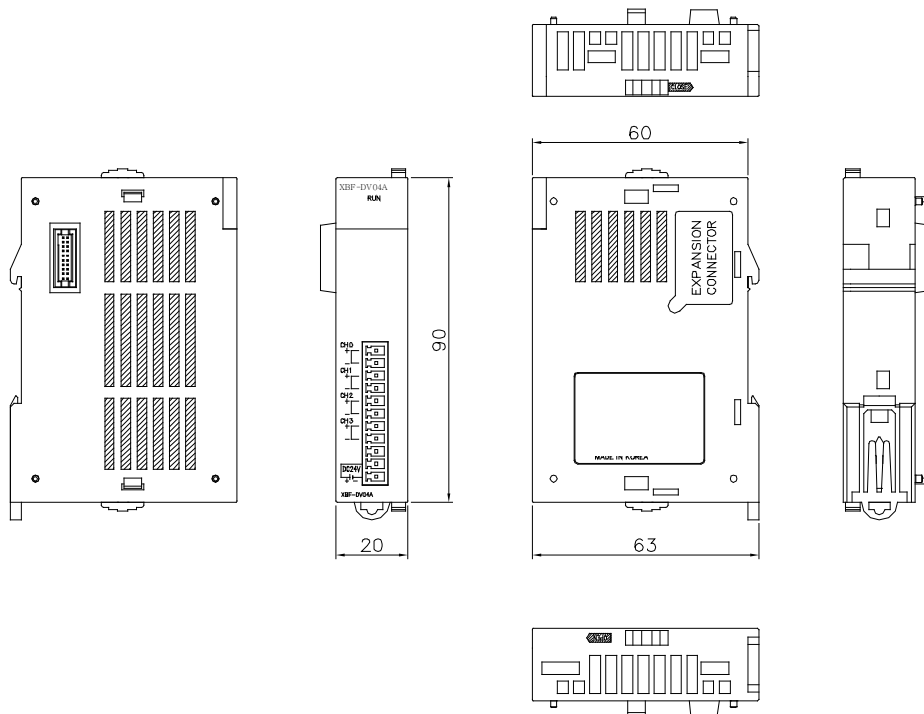

4) Dimension of XBF-RD04A / XBF-AD04C

Unit: mm

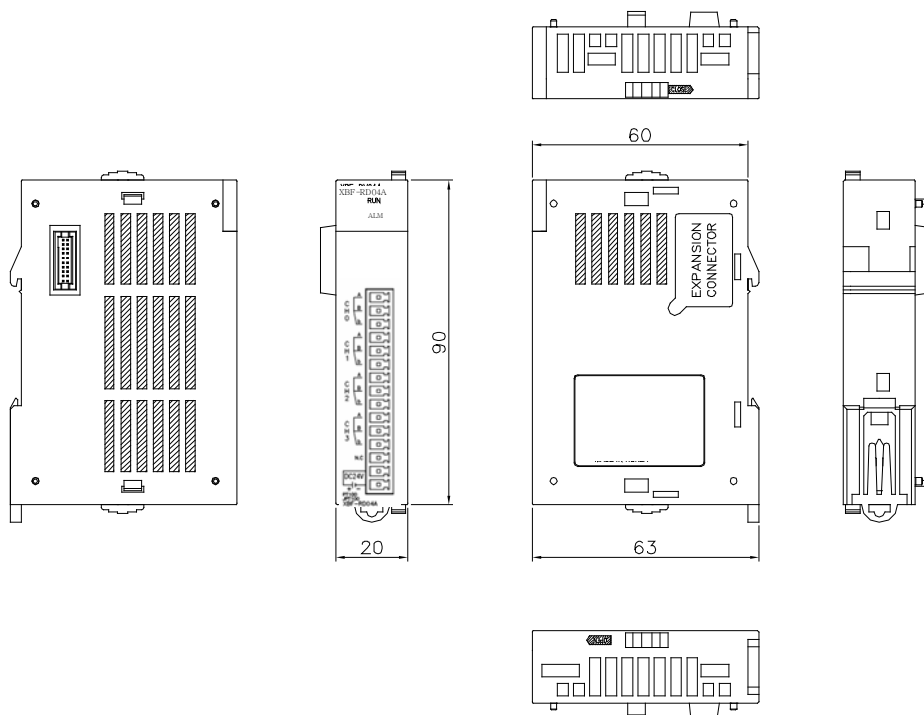

5) Dimension of XBF-TC04S

Unit: mm

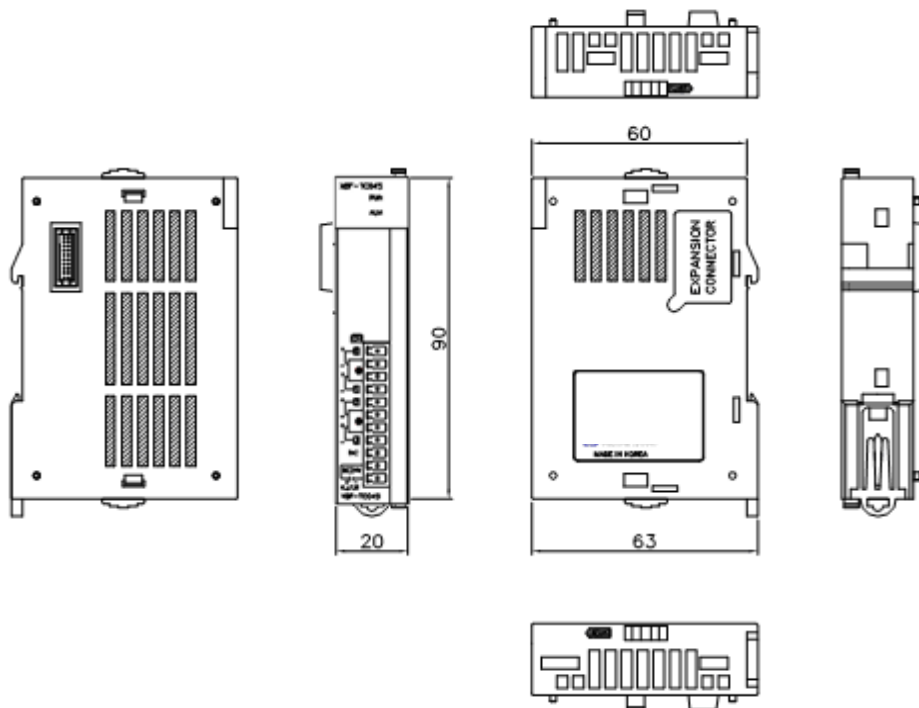

6) Dimension of XBF-AH04A

Unit: mm

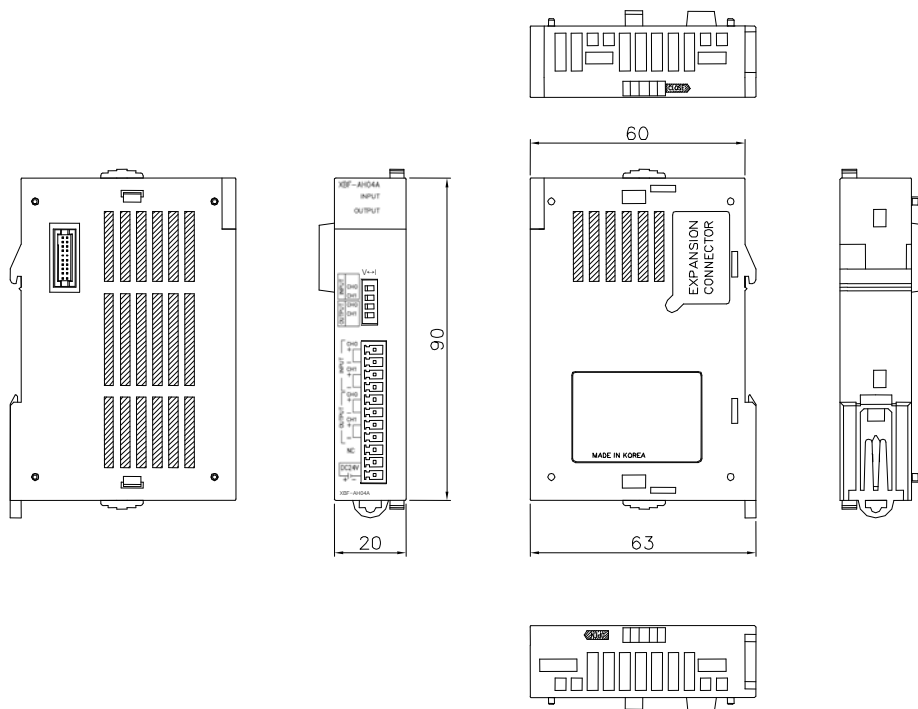

7) Dimension of XBF-AD08A

Unit: mm

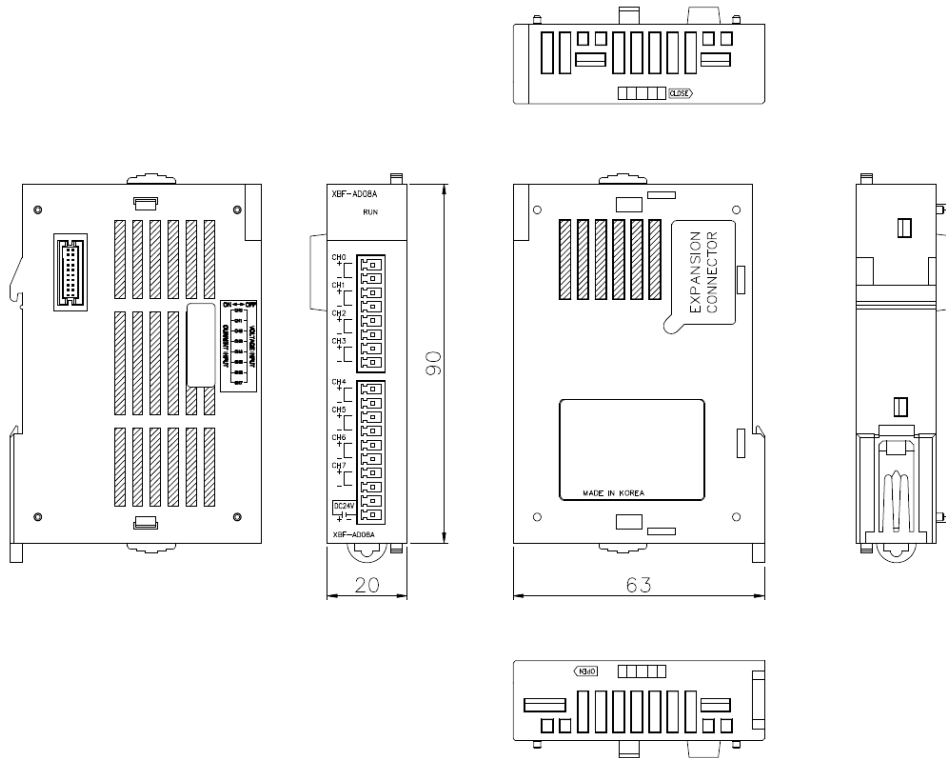

8) Dimension of XBO-AD02A

Unit: mm

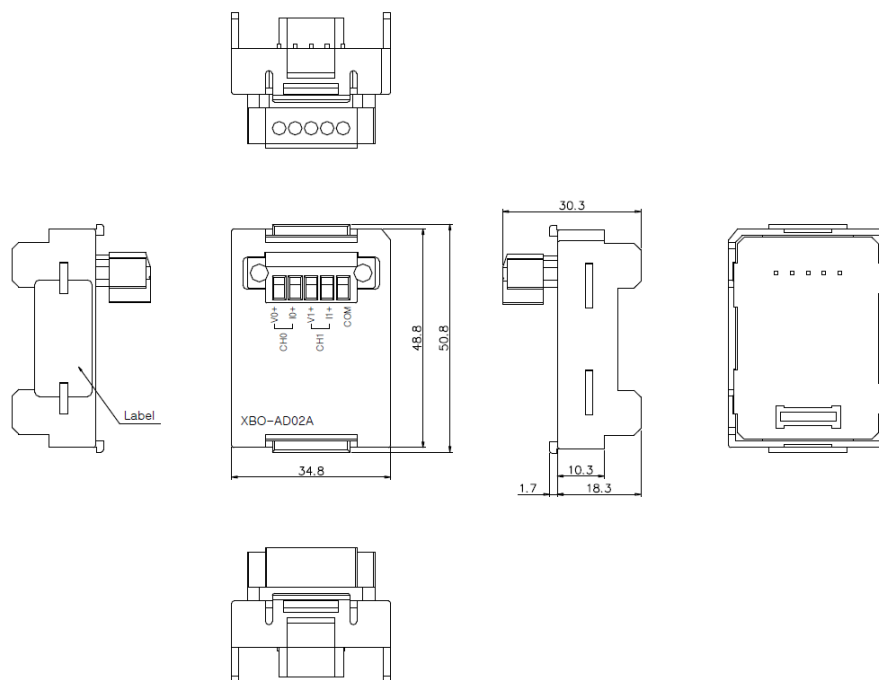

9) Dimension of XBO-DA02A

Unit: mm

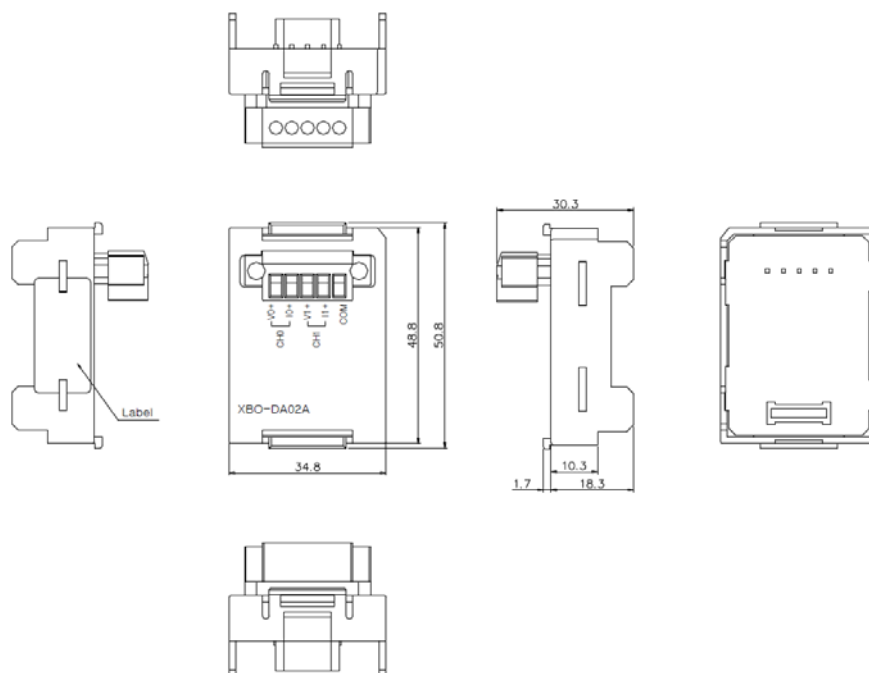

10) Dimension of XBO-AH02A

Unit: mm

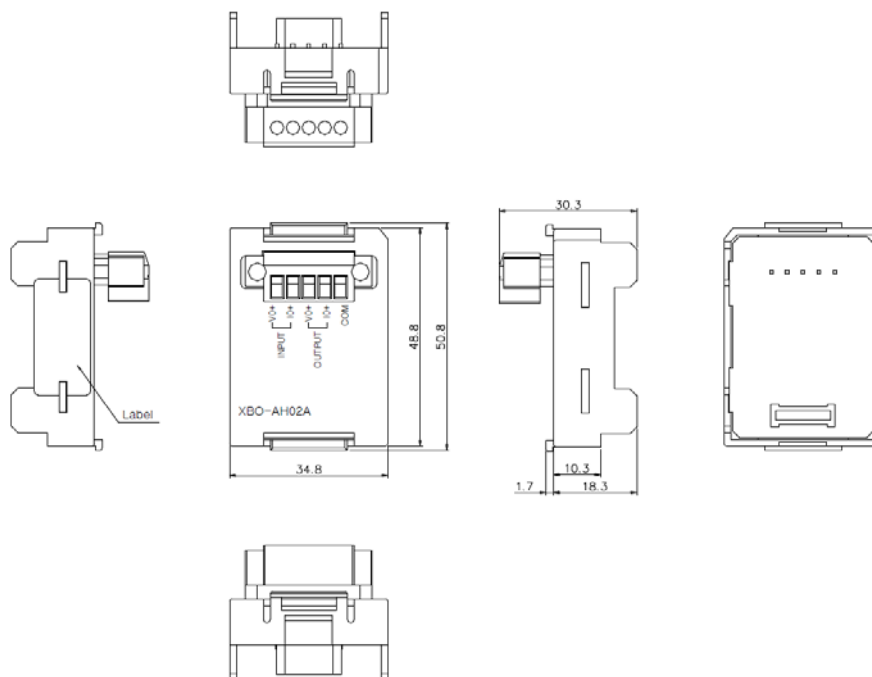

11) Dimension of XBO-RD01A

Unit: mm

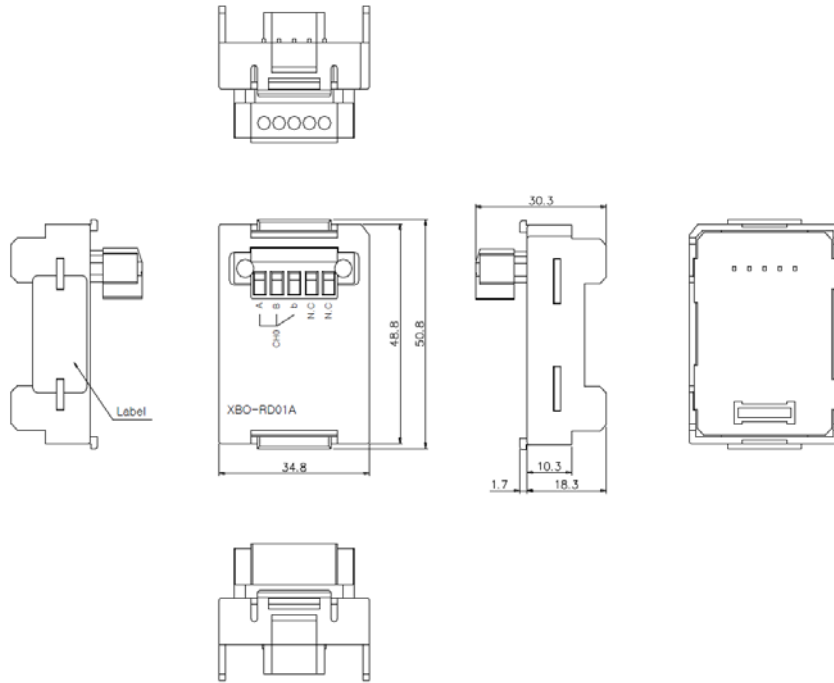

12) Dimension of XBO-TC02A

Unit: mm

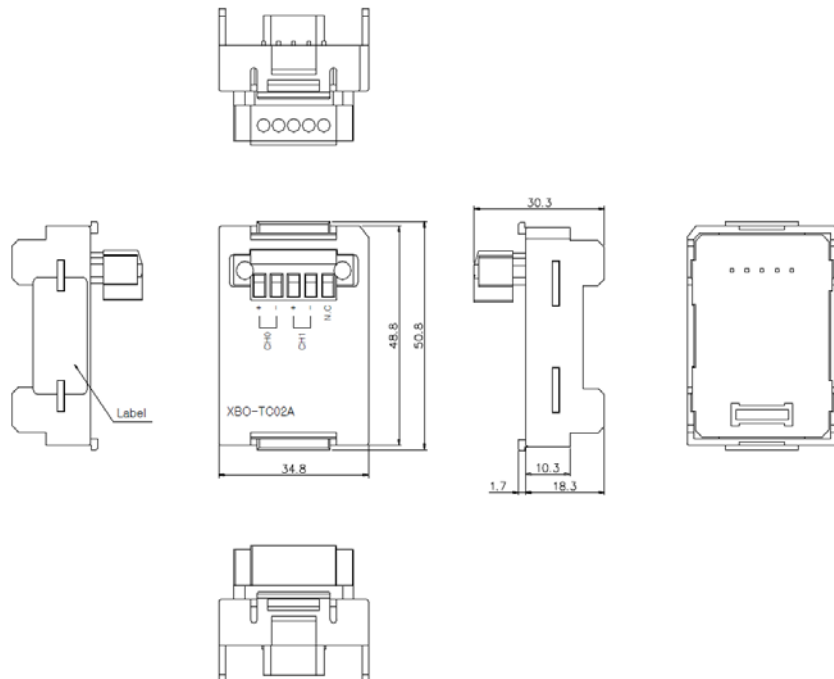



[www.ls-electric.com](http://www.ls-electric.com)

## LS ELECTRIC Co., Ltd.

### ■ Headquarter

LS-ro 127(Hogye-dong) Dongan-gu, Anyang-si, Gyeonggi-Do, 14119, Korea

### ■ Seoul Office

LS Yongsan Tower, 92, Hangang-daero, Yongsan-gu, Seoul, 04386, Korea

Tel: 82-2-2034-4033, 4888, 4703 Fax: 82-2-2034-4588

E-mail: [automation@ls-electric.com](mailto:automation@ls-electric.com)

### ■ Overseas Subsidiaries

#### • LS ELECTRIC Japan Co., Ltd. (Tokyo, Japan)

Tel: 81-3-6268-8241 E-Mail: [japan@ls-electric.com](mailto:japan@ls-electric.com)

#### • LS ELECTRIC (Dalian) Co., Ltd. (Dalian, China)

Tel: 86-411-8730-6495 E-Mail: [china.dalian@lselectric.com.cn](mailto:china.dalian@lselectric.com.cn)

#### • LS ELECTRIC (Wuxi) Co., Ltd. (Wuxi, China)

Tel: 86-510-6851-6666 E-Mail: [china.wuxi@lselectric.com.cn](mailto:china.wuxi@lselectric.com.cn)

#### • LS ELECTRIC Middle East FZE (Dubai, U.A.E.)

Tel: 971-4-886-5360 E-Mail: [middleeast@ls-electric.com](mailto:middleeast@ls-electric.com)

#### • LS ELECTRIC Europe B.V. (Hoofddorp, Netherlands)

Tel: 31-20-654-1424 E-Mail: [europartner@ls-electric.com](mailto:europartner@ls-electric.com)

#### • LS ELECTRIC America Inc. (Chicago, USA)

Tel: 1-800-891-2941 E-Mail: [sales.us@lselectricamerica.com](mailto:sales.us@lselectricamerica.com)

#### • LS ELECTRIC Turkey Co., Ltd.

Tel: 90-212-806-1225 E-Mail: [turkey@ls-electric.com](mailto:turkey@ls-electric.com)

### ■ Overseas Branches

#### • LS ELECTRIC Tokyo Office (Japan)

Tel: 81-3-6268-8241 E-Mail: [tokyo@ls-electric.com](mailto:tokyo@ls-electric.com)

#### • LS ELECTRIC Beijing Office (China)

Tel: 86-10-5095-1631 E-Mail: [china.auto@lselectric.com.cn](mailto:china.auto@lselectric.com.cn)

#### • LS ELECTRIC Shanghai Office (China)

Tel: 86-21-5237-9977 E-Mail: [china.auto@lselectric.com.cn](mailto:china.auto@lselectric.com.cn)

#### • LS ELECTRIC Guangzhou Office (China)

Tel: 86-20-3818-2883 E-Mail: [china.auto@lselectric.com.cn](mailto:china.auto@lselectric.com.cn)

#### • LS ELECTRIC Chengdu Office (China)

Tel: 86-28-8670-3201 E-Mail: [china.auto@lselectric.com.cn](mailto:china.auto@lselectric.com.cn)

#### • LS ELECTRIC Qingdao Office (China)

Tel: 86-532-8501-2065 E-Mail: [china.auto@lselectric.com.cn](mailto:china.auto@lselectric.com.cn)

#### • LS ELECTRIC Nanjing Office (China)

Tel: 86-25-8467-0005 E-Mail: [china.auto@lselectric.com.cn](mailto:china.auto@lselectric.com.cn)

#### • LS ELECTRIC Bangkok Office (Thailand)

Tel: 66-90-950-9683 E-Mail: [thailand@ls-electric.com](mailto:thailand@ls-electric.com)

#### • LS ELECTRIC Jakarta Office (Indonesia)

Tel: 62-21-2933-7614 E-Mail: [indonesia@ls-electric.com](mailto:indonesia@ls-electric.com)

#### • LS ELECTRIC Moscow Office (Russia)

Tel: 7-499-682-6130 E-Mail: [info@lselectric-ru.com](mailto:info@lselectric-ru.com)

#### • LS ELECTRIC America Western Office (Irvine, USA)

Tel: 1-949-333-3140 E-Mail: [america@ls-electric.com](mailto:america@ls-electric.com)

### Disclaimer of Liability

LS ELECTRIC has reviewed the information in this publication to ensure consistency with the hardware and software described. However, LS ELECTRIC cannot guarantee full consistency, nor be responsible for any damages or compensation, since variance cannot be precluded entirely. Please check again the version of this publication before you use the product.

© LS ELECTRIC Co., Ltd 2015 All Right Reserved.

2023.02